



Chipsmall Limited consists of a professional team with an average of over 10 year of expertise in the distribution of electronic components. Based in Hongkong, we have already established firm and mutual-benefit business relationships with customers from,Europe,America and south Asia,supplying obsolete and hard-to-find components to meet their specific needs.

With the principle of “Quality Parts,Customers Priority,Honest Operation,and Considerate Service”,our business mainly focus on the distribution of electronic components. Line cards we deal with include Microchip,ALPS,ROHM,Xilinx,Pulse,ON,Everlight and Freescale. Main products comprise IC,Modules,Potentiometer,IC Socket,Relay,Connector.Our parts cover such applications as commercial,industrial, and automotives areas.

We are looking forward to setting up business relationship with you and hope to provide you with the best service and solution. Let us make a better world for our industry!



Contact us

Tel: +86-755-8981 8866 Fax: +86-755-8427 6832

Email & Skype: info@chipsmall.com Web: www.chipsmall.com

Address: A1208, Overseas Decoration Building, #122 Zhenhua RD., Futian, Shenzhen, China



Silicon Wafer Mapping Sensor

F3M-S825-1

Allows Simultaneous Mapping of Up to 25 Silicon Wafers

- Economical—one sensor detects most wafer types
- 200 mm wafer size
- Automatic and remote teaching capability
- Self-diagnostic functions reduce downtime



Ordering Information

Applicable wafer size	Number of cassette slots	Function	Remarks	Part number
8 inches (6.35-mm pitch)	25	Self-diagnosis	CE marking	F3M-S825-1

Application Examples

Detects Transparent Glass Wafers With a Transparency of 92%

The F3M-S825-1 allows the mapping of cassettes that have both silicon wafers and glass wafers.

Automatic Teaching Saves Setting Time (Remote Teaching Available)

The F3M-S825-1 has an automatic teaching function that ensures easy adjustments in minimal time. The remote teaching function allows quick, on-the-fly set up.

Answer-back Alarms for Setting Errors and Self-diagnostic Alarms for Operation Errors

These alarms help reduce system downtime and shorten troubleshooting time.

Static Electricity Protection

OMRON's optical system (including emitter and receiver) prevents malfunction and damage—protecting the Sensor from static electricity if charged on the semiconductor wafers at the time of mapping.

Specifications

■ RATINGS/CHARACTERISTICS

Item		F3M-S825-1
Target object		8-inch semiconductor silicon wafers and transparent wafers (with transparency of 92% max.) (See Note.)
Number of channels		25
Optical axis pitch		6.35 mm
Optical axis width		1.5 mm
Light source		Infrared LED (940 nm)
Power supply voltage		12 to 24 VDC $\pm 10\%$, ripple (p-p): 10% max.
Current consumption		120 mA max.
Output	Control output	Load power supply voltage: 30 VDC Load current: 20 mA max. (residual voltage: 1 V max.); Inflow current: 20 mA.; Parallel output from all channels, NPN open collector; Dark-ON operation.
	Answer-back output	When remote teaching is ON, pin 28 will be used for this function.
	Self-diagnostic output	Load power supply voltage: 30 VDC max.; Load current: 20 mA max. (Residual voltage: 1 V max.); Inflow current: 20 mA; NPN open collector.
Indicators	Power	Green indicator is ON when power is being supplied.
	Warning	Red indicator is ON under the following conditions: Teaching, no target object, insufficient light, or error.
Response time		10 ms max.
Control output interrupt input		All outputs interrupted: GND and control output interrupt input terminals are short-circuited and 0-V short-circuit current is 1 mA max.; Output interrupt reset: GND and control output interrupt input terminals are opened or the voltage is between 9 V and the working power supply voltage.
Remote teaching input	ON	GND and remote input terminals are short-circuited and 0-V short-circuit current is 1 mA max.
	OFF	GND and remote input terminals are opened or the voltage is between 9 V and the working power supply voltage.
Teaching check function		Orange LED indicator
Ambient temperature	Operating	0°C to 40°C (32°F to 104°F) with no icing or condensation
	Storage	-25°C to 60°C (-13°F to 140°F)
Relative humidity		35% to 85% with no condensation
Ambient illumination		Fluorescent lamp: 1,500 lx max.
Noise resistance		Power supply line: ± 480 V in normal mode with noise simulator
		Static electrical noise: No malfunction or destruction at ± 8 kV
Vibration resistance		10 to 55 Hz, 0.5 mm double amplitude for 2 hrs each in X, Y, and Z axes
Shock resistance		300 m/s ² (30G) 3 times each in X, Y, and Z axes
Degree of protection		IEC60529 IP40
Connection		Pre-wired cable (length: 500 mm ± 35 mm) IDC connector (insulation displacement)
Weight (packed state)		Approx. 110 g (3.8 oz)
Material	Optical axis	Polycarbonate
	Case	ABS
	Cable	Vinyl-insulated, bending type
Accessories		Spacer and instruction manual

Note: Operating conditions are restricted for the detection of transparent wafers. Contact your OMRON representatives for details.

■ AUTOMATIC TEACHING FUNCTION

F3M-S825-1

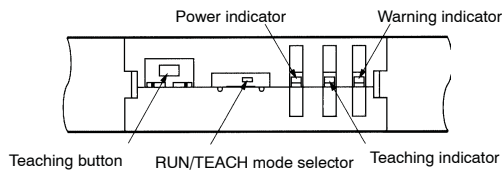

The remote or manual automatic teaching of the F3M-S825-1 is possible with the following two sensitivity settings:

1. Max. Sensitivity Setting: Detects semiconductor silicon wafers, and SIC wafers.
2. Teaching with No Target Object: Detects transparent wafers.

The sensitivity is set to maximum before shipping. Refer to the Instruction Manual when setting the sensitivity of the F3M-S825-1.

■ ANSWER-BACK FUNCTION AND SELF-DIAGNOSTIC FUNCTION

The F3M-S825-1 has an answer-back function to warn the user about setting errors and a self-diagnostic function to warn the user about operational errors.

- Answer-back Function: Normal or error teaching output turns ON.
- Self-diagnostic Function: Warning output turns ON for a decrease in optical input.

Operation

■ OUTPUT CIRCUIT DIAGRAM

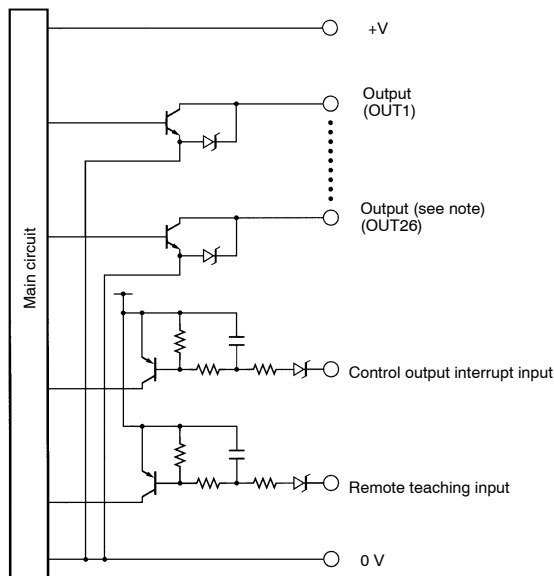

■ I/O TERMINAL ARRANGEMENT

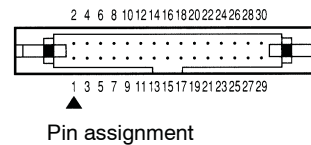

Pin	Assignment	Pin	Assignment
1	GND (0 V)	16	OUT14
2	V _{CC} (12 to 24 V)	17	OUT15
3	OUT1	18	OUT16
4	OUT2	19	OUT17
5	OUT3	20	OUT18
6	OUT4	21	OUT19
7	OUT5	22	OUT20
8	OUT6	23	OUT21
9	OUT7	24	OUT22
10	OUT8	25	OUT23
11	OUT9	26	OUT24
12	OUT10	27	OUT25
13	OUT11	28	Self-diagnostic output/OUT26 (See Note.)
14	OUT12	29	Control output interrupt input
15	OUT13	30	Remote teaching input

Note: Pin 28 will have answer-back output only when remote teaching input is turned ON. Otherwise, this output is a self-diagnostic output.

Dimensions

Unit: mm (inch)

■ F3M-S825-1

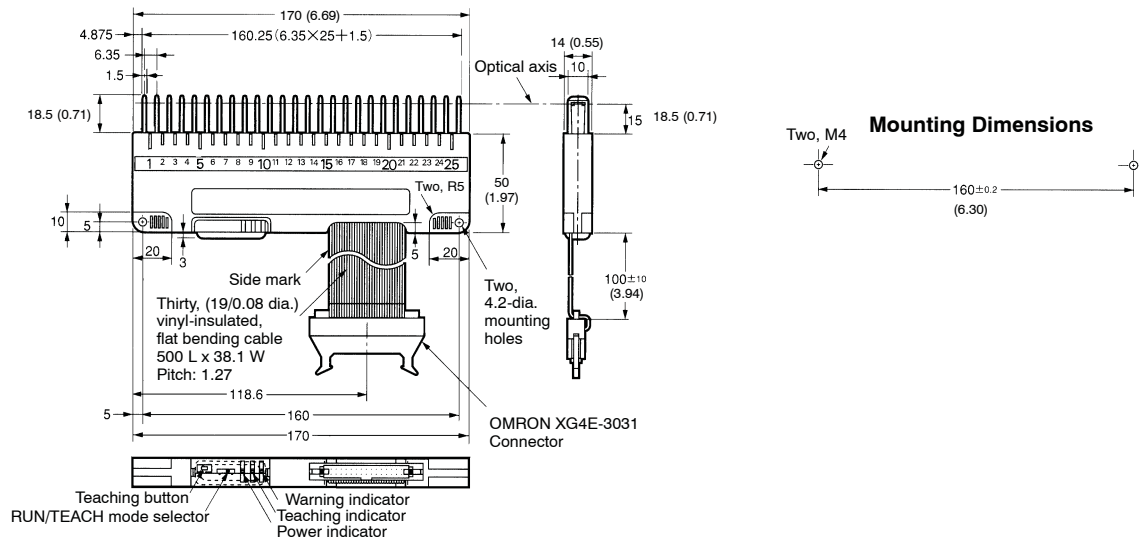

Precautions

■ CORRECT USE—TO AVOID DAMAGE

- Do not use the F3M-S825-1 at a voltage that exceeds the rated voltage range.
- Do not make mistakes in wiring, such as mistakes in polarity.
- Do not short-circuit the load.
- Do not connect AC to the F3M-S825-1.

■ INSTALLATION/ENVIRONMENT

Do NOT use the F3M-S825-1 in the following locations:

- Locations exposed to direct sunlight.
- Locations with high humidity that may cause condensation.
- Locations with corrosive gas.
- Locations where vibration or shock directly affects the Sensor.

■ CLEANING

Do not attempt to clean the F3M-S825-1 using paint thinner, to avoid damaging the surface of the Sensor.

■ CONNECTION AND MOUNTING

- A maximum of 24 VDC+10% can be imposed on the F3M-S825-1. Check that the voltage of the power supply is within the permissible range before turning on the F3M-S825-1. The power supply must be constructed so that the secondary circuit is insulated with an isolating transformer.
- Do not wire power lines or high-voltage lines within the same conduit with the lines of the F3M-S825-1, or the sensor may be damaged or malfunction.
- Avoid mechanical impact when mounting the F3M-S825-1, or its water-resistant properties will be reduced.

■ POWER SUPPLY

If a standard switching power supply is connected to the F3M-S825-1, be sure to ground the FG (frame ground) and G (ground) terminals of the power supply. If these terminals are not grounded, the Sensor may malfunction due to switching noise that will be generated from the power supply.

NOTE: DIMENSIONS SHOWN ARE IN MILLIMETERS. To convert millimeters to inches divide by 25.4.

OMRON®

OMRON ELECTRONICS, INC.

One East Commerce Drive
Schaumburg, IL 60173

1-800-55-OMRON

OMRON CANADA, INC.

885 Milner Avenue
Scarborough, Ontario M1B 5V8

416-286-6465