



Chipsmall Limited consists of a professional team with an average of over 10 year of expertise in the distribution of electronic components. Based in Hongkong, we have already established firm and mutual-benefit business relationships with customers from,Europe,America and south Asia,supplying obsolete and hard-to-find components to meet their specific needs.

With the principle of “Quality Parts,Customers Priority,Honest Operation,and Considerate Service”,our business mainly focus on the distribution of electronic components. Line cards we deal with include Microchip,ALPS,ROHM,Xilinx,Pulse,ON,Everlight and Freescale. Main products comprise IC,Modules,Potentiometer,IC Socket,Relay,Connector.Our parts cover such applications as commercial,industrial, and automotives areas.

We are looking forward to setting up business relationship with you and hope to provide you with the best service and solution. Let us make a better world for our industry!



## Contact us

Tel: +86-755-8981 8866 Fax: +86-755-8427 6832

Email & Skype: info@chipsmall.com Web: www.chipsmall.com

Address: A1208, Overseas Decoration Building, #122 Zhenhua RD., Futian, Shenzhen, China



| REVISIONS |      |                              |
|-----------|------|------------------------------|
| ISS       | ZONE | DESCRIPTION\PER REQUEST\DATE |
|           |      |                              |

CONFIGURATION CONTROL:  
NO CHANGES PERMITTED TO DRAWING WITHOUT  
PPAP QUALIFIED CUSTOMER APPROVAL

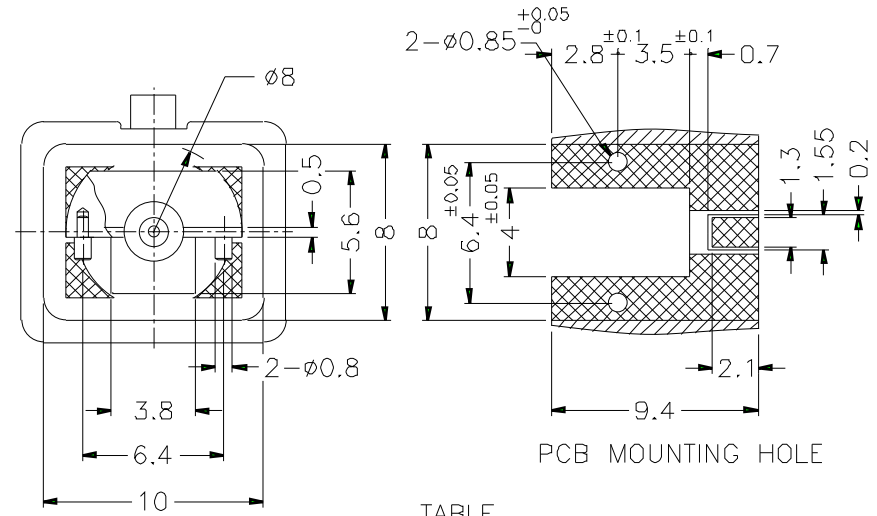
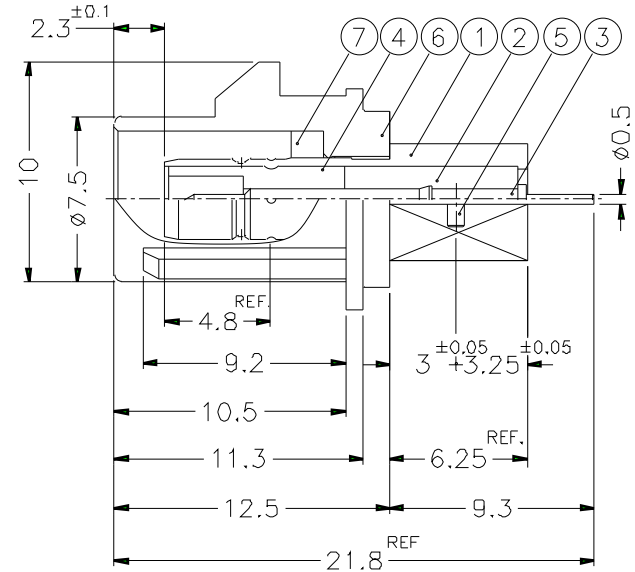
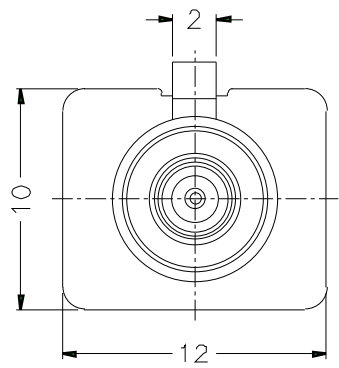

TABLE

| KEY CODING | D/N                | P/N            | LOCK COVER |
|------------|--------------------|----------------|------------|
| A          | FK1251AW-3GT30G-50 | FA1-NASP-PCB-0 | FKLC10201A |
| B          | FK1251BW-3GT30G-50 | FA1-NBSP-PCB-0 | FKLC10202A |
| C          | FK1251CW-3GT30G-50 | FA1-NCSP-PCB-0 | FKLC10203A |
| D          | FK1251DW-3GT30G-50 | FA1-NDSP-PCB-0 | FKLC10204A |
| E          | FK1251EW-3GT30G-50 | FA1-NESP-PCB-0 | FKLC10205A |
| F          | FK1251FW-3GT30G-50 | FA1-NFSP-PCB-0 | FKLC10206A |
| G          | FK1251GW-3GT30G-50 | FA1-NGSP-PCB-0 | FKLC10207A |
| H          | FK1251HW-3GT30G-50 | FA1-NHSP-PCB-0 | FKLC10208A |
| I          | FK1251IW-3GT30G-50 | FA1-NISP-PCB-0 | FKLC10209A |
| K          | FK1251KW-3GT30G-50 | FA1-NKSP-PCB-0 | FKLC10210A |
| Z          | FK1251ZW-3GT30G-50 | FA1-NZSP-PCB-0 | FKLC10211A |

NOTES: FINISH (PLATING THICKNESS IN MICRO-INCHES)  
 1. BRASS PER QQ-B-626, ALLOY 360, 1/2 H ; JIS H3250 C 3604BD OR EQUIVALENT  
 2. GOLD PL. 30 MIN. THICK OVER NICKEL PL. 100 MIN. THICK OVER COPPER STRIKE  
 3. GOLD PL. 3 MIN. THICK OVER NICKEL PL. 100 MIN. THICK OVER COPPER STRIKE  
 4. TEFLON MIL-P-19468  
 5. PBT(WITH 15% GLASS FIBER) PER CHANG CHUN GRADE 4115202 OR EQUIVALENT

|     |             |          |         |      |                     |                                                                                                                                                                               |                |                          |                                                                |                                |
|-----|-------------|----------|---------|------|---------------------|-------------------------------------------------------------------------------------------------------------------------------------------------------------------------------|----------------|--------------------------|----------------------------------------------------------------|--------------------------------|
| 7   | RING        | NOTE 1   | NOTE 3  | 1    | FKLR00101A          | DIMENSIONS ARE IN MILLIMETERS<br>UNLESS OTHERWISE SPECIFIED TOLERANCES<br>0.5-6 = ±0.2<br>6-30 = ±0.4<br>30-120 = ±0.6<br>120-315 = ±1<br>315-1000 = ±1.6<br>1000-2000 = ±2.4 | PART NO.       |                          | <b>Amphenol</b><br>Danbury,CT,USA-Tainan,Taiwan-Shenzhen,China |                                |
| 6   | LOCK COVER  | NOTE 5   |         | 1    | SEE TABLE           |                                                                                                                                                                               | FA1-NXSP-PCB-0 |                          |                                                                | TITLE                          |
| 5   | PIN         | NOTE 1   | NOTE 3  | 2    | SMB125100-003-5     |                                                                                                                                                                               | APPROVED       | DATE                     |                                                                | FAKRA EDGE CARD PCB MOUNT PLUG |
| 4   | INSULATOR   | NOTE 4   | NATURAL | 1    | SMB2071A1-2T-50     |                                                                                                                                                                               | CHECKED        | DATE                     |                                                                | DRAWING NO.                    |
| 3   | CONTACT PIN | NOTE 1   | NOTE 2  | 1    | SMB125100-003-3     |                                                                                                                                                                               | DRAWN          | DATE                     |                                                                | KJ-FK1251XX-3GT30G-50          |
| 2   | INSULATOR   | NOTE 4   | NATURAL | 1    | SMB125100-003-2T-50 | ANGELA                                                                                                                                                                        |                | FILE NO.                 |                                                                |                                |
| 1   | BODY        | NOTE 1   | NOTE 3  | 1    | SMB125100-003-1     |                                                                                                                                                                               |                | F:\DWG\FK\FA1\NXSP\PCB\0 |                                                                |                                |
| NO. | DESCRIPTION | MATERIAL | FINISH  | Q'TY | DRAWING NO.         | SCALE                                                                                                                                                                         | 3/1            | ISSUE                    | 1                                                              |                                |