



Chipsmall Limited consists of a professional team with an average of over 10 year of expertise in the distribution of electronic components. Based in Hongkong, we have already established firm and mutual-benefit business relationships with customers from,Europe,America and south Asia,supplying obsolete and hard-to-find components to meet their specific needs.

With the principle of "Quality Parts,Customers Priority,Honest Operation,and Considerate Service",our business mainly focus on the distribution of electronic components. Line cards we deal with include Microchip,ALPS,ROHM,Xilinx,Pulse,ON,Everlight and Freescale. Main products comprise IC,Modules,Potentiometer,IC Socket,Relay,Connector.Our parts cover such applications as commercial,industrial, and automotives areas.

We are looking forward to setting up business relationship with you and hope to provide you with the best service and solution. Let us make a better world for our industry!



Contact us

Tel: +86-755-8981 8866 Fax: +86-755-8427 6832

Email & Skype: info@chipsmall.com Web: www.chipsmall.com

Address: A1208, Overseas Decoration Building, #122 Zhenhua RD., Futian, Shenzhen, China





Is Now Part of



ON Semiconductor®

To learn more about ON Semiconductor, please visit our website at
www.onsemi.com

ON Semiconductor and the ON Semiconductor logo are trademarks of Semiconductor Components Industries, LLC dba ON Semiconductor or its subsidiaries in the United States and/or other countries. ON Semiconductor owns the rights to a number of patents, trademarks, copyrights, trade secrets, and other intellectual property. A listing of ON Semiconductor's product/patent coverage may be accessed at www.onsemi.com/site/pdf/Patent-Marking.pdf. ON Semiconductor reserves the right to make changes without further notice to any products herein. ON Semiconductor makes no warranty, representation or guarantee regarding the suitability of its products for any particular purpose, nor does ON Semiconductor assume any liability arising out of the application or use of any product or circuit, and specifically disclaims any and all liability, including without limitation special, consequential or incidental damages. Buyer is responsible for its products and applications using ON Semiconductor products, including compliance with all laws, regulations and safety requirements or standards, regardless of any support or applications information provided by ON Semiconductor. "Typical" parameters which may be provided in ON Semiconductor data sheets and/or specifications can and do vary in different applications and actual performance may vary over time. All operating parameters, including "Typicals" must be validated for each customer application by customer's technical experts. ON Semiconductor does not convey any license under its patent rights nor the rights of others. ON Semiconductor products are not designed, intended, or authorized for use as a critical component in life support systems or any FDA Class 3 medical devices or medical devices with a same or similar classification in a foreign jurisdiction or any devices intended for implantation in the human body. Should Buyer purchase or use ON Semiconductor products for any such unintended or unauthorized application, Buyer shall indemnify and hold ON Semiconductor and its officers, employees, subsidiaries, affiliates, and distributors harmless against all claims, costs, damages, and expenses, and reasonable attorney fees arising out of, directly or indirectly, any claim of personal injury or death associated with such unintended or unauthorized use, even if such claim alleges that ON Semiconductor was negligent regarding the design or manufacture of the part. ON Semiconductor is an Equal Opportunity/Affirmative Action Employer. This literature is subject to all applicable copyright laws and is not for resale in any manner.



FAN2106 — 3-24 V Input, 6 A, High-Efficiency, Integrated Synchronous Buck Regulator

Features

- 6 A Output Current
- Wide Input Range: 3 V - 24 V
- Output Voltage Range: 0.8 V to 80% V_{IN}
- Over 95% Peak Efficiency
- 1% Reference Accuracy Over Temperature
- Programmable Frequency Operation: 200 KHz to 600 KHz
- Fully Synchronous Operation with Integrated Schottky Diode on Low-Side MOSFET Boosts Efficiency
- Internal Bootstrap Diode
- Internal Soft-Start
- Power-Good Signal
- Starts on Pre-Biased Outputs
- Accepts Ceramic Capacitors on Output
- External Compensation for Flexible Design
- Programmable Current Limit
- Under-Voltage, Over-Voltage, and Thermal Protections
- 5x6 mm, 25-Pin, 3-Pad MLP Package

Applications

- Servers & Telecom
- Graphics Cards & Displays
- Computing Systems
- Point-of-Load Regulation
- Set-Top Boxes & Game Consoles

Description

The FAN2106 is a highly efficient, small-footprint, constant-frequency, 6 A, integrated synchronous buck regulator.

The FAN2106 contains both synchronous MOSFETs and a controller/driver with optimized interconnects in one package, which enables designers to solve high-current requirements in a small area with minimal external components. Integration helps to minimize critical inductances, making component layout simpler and more efficient compared to discrete solutions.

The FAN2106 provides for external loop compensation, programmable switching frequency, and current limit. These features allow design flexibility and optimization. High-frequency operation allows for all-ceramic solutions.

The summing current-mode modulator uses lossless current sensing for current feedback and over-current protection. Voltage feedforward helps operation over a wide input voltage range.

Fairchild's advanced BiCMOS power process, combined with low- $R_{DS(ON)}$ internal MOSFETs and a thermally efficient MLP package, provide the ability to dissipate high power in a small package.

Output over-voltage, under-voltage, over-current, and thermal shutdown protections help protect the device from damage during fault conditions. FAN2106 prevents pre-biased output discharge during startup in point-of-load applications.

Related Resources

- [AN-8022 — TinyCalc™ Calculator User Guide](#)
- [TinyCalc™ Calculator Design Tool](#)

Ordering Information

Part Number	Operating Temperature Range	Package	Packing Method
FAN2106MPX	-40°C to 85°C	Molded Leadless Package (MLP) 5 x 6 mm	Tape and Reel
FAN2106EMPX			

Typical Application Diagram

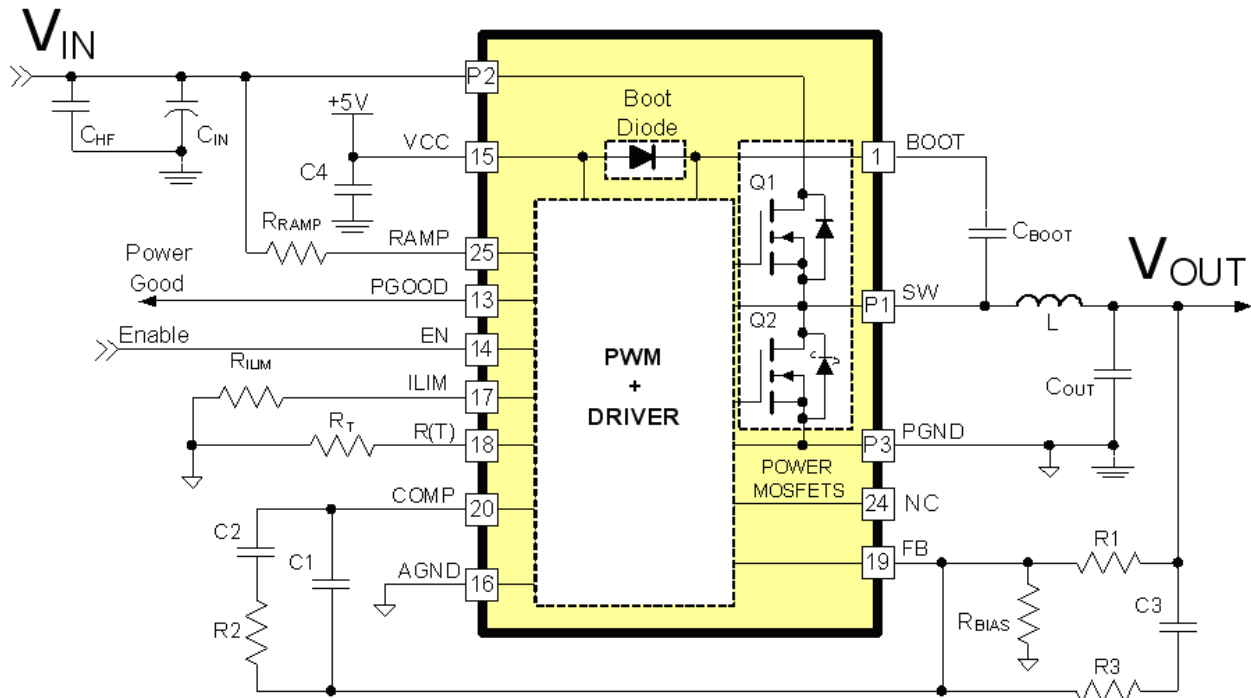

Figure 1. Typical Application

Block Diagram

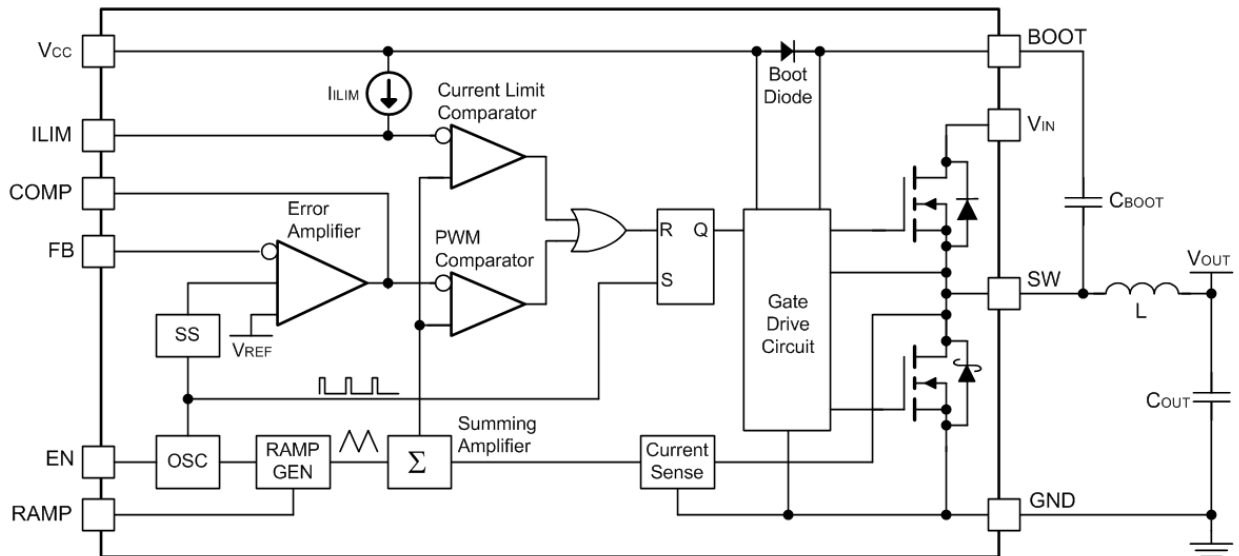

Figure 2. Block Diagram

Pin Configuration

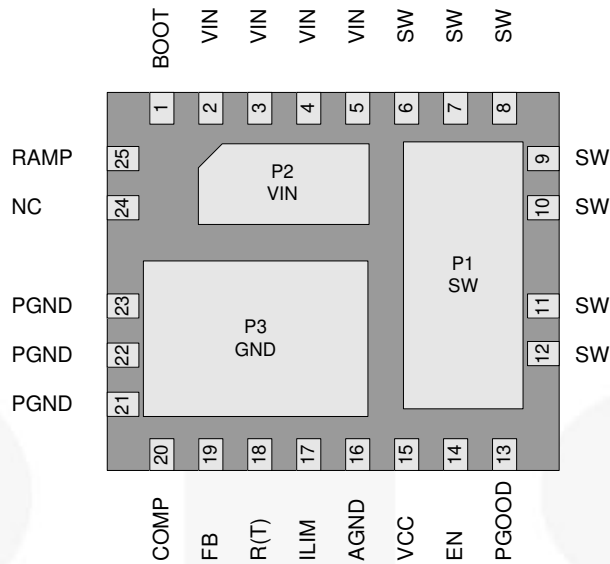

Figure 3. MLP 5 x 6 mm Pin Configuration (Bottom View)

Pin Definitions

Pin #	Name	Description
P1, 6-12	SW	Switching Node. Junction of high-side and low-side MOSFETs.
P2, 2-5	VIN	Power Input Voltage. Connect to the main input power source.
P3, 21-23	PGND	Power Ground. Power return and Q2 source.
1	BOOT	High-Side Drive BOOT Voltage. Connect through capacitor (C_{BOOT}) to SW. The IC includes an internal synchronous bootstrap diode to recharge the capacitor on this pin to V_{CC} when SW is LOW.
13	PGOOD	Power-Good Flag. An open-drain output that pulls LOW when FB is outside the limits specified in electrical specs. PGOOD does not assert HIGH until the fault latch is enabled.
14	EN	ENABLE. Enables operation when pulled to logic HIGH or left open. Toggling EN resets the regulator after a latched fault condition. This input has an internal pull-up when the IC is functioning normally. When a latched fault occurs, EN is discharged by a current sink.
15	VCC	Input Bias Supply for IC. The IC's logic and analog circuitry are powered from this pin. This pin should be decoupled to AGND through a $>1 \mu F$ X5R/X7R capacitor.
16	AGND	Analog Ground. The signal ground for the IC. All internal control voltages are referred to this pin. Tie this pin to the ground island/plane through the lowest impedance connection.
17	ILIM	Current Limit. A resistor (R_{ILIM}) from this pin to AGND can be used to program the current-limit trip threshold lower than the default setting.
18	R(T)	Oscillator Frequency. A resistor (R_T) from this pin to AGND sets the PWM switching frequency.
19	FB	Output Voltage Feedback. Connect through a resistor divider to the output voltage.
20	COMP	Compensation. Error amplifier output. Connect the external compensation network between this pin and FB.
24	NC	No Connect. This pin is not used.
25	RAMP	Ramp Amplitude. A resistor (R_{RAMP}) connected from this pin to VIN sets the ramp amplitude and provides voltage feedforward functionality.

Absolute Maximum Ratings

Stresses exceeding the absolute maximum ratings may damage the device. The device may not function or be operable above the recommended operating conditions and stressing the parts to these levels is not recommended. In addition, extended exposure to stresses above the recommended operating conditions may affect device reliability. The absolute maximum ratings are stress ratings only.

Parameter	Conditions	Min.	Max.	Unit
V _{IN} to PGND			28	V
V _{CC} to AGND	AGND = PGND		6	V
BOOT to PGND			35	V
BOOT to SW		-0.3	6.0	V
SW to PGND	Continuous	-0.5	24.0	V
	Transient (t < 20 ns, f ≤ 600 KHz)	-5.0	30.0	
All other pins		-0.3	V _{CC} +0.3	V
ESD	Human Body Model, JEDEC JESD22-A114	2.0		kV
	Charged Device Model, JEDEC JESD22-C101	2.5		

Recommended Operating Conditions

The Recommended Operating Conditions table defines the conditions for actual device operation. Recommended operating conditions are specified to ensure optimal performance to the datasheet specifications. Fairchild does not recommend exceeding them or designing to absolute maximum ratings.

Symbol	Parameter	Conditions	Min.	Typ.	Max.	Unit
V _{CC}	Bias Voltage	V _{CC} to AGND	4.5	5.0	5.5	V
V _{IN}	Supply Voltage	V _{IN} to PGND	3		24	V
T _A	Ambient Temperature		-40		+85	°C
T _J	Junction Temperature				+125	°C
f _{SW}	Switching Frequency		200		600	KHz

Thermal Information

Symbol	Parameter	Min.	Typ.	Max.	Unit
T _{STG}	Storage Temperature	-65		+150	°C
T _L	Lead Soldering Temperature, 10 Seconds			+300	°C
θ _{JC}	Thermal Resistance: Junction-to-Case	P1 (Q2)	4		°C/W
		P2 (Q1)	7		
		P3	4		
θ _{J-PCB}	Thermal Resistance: Junction-to-Mounting Surface		35 ⁽¹⁾		°C/W
P _D	Power Dissipation, T _A = 25°C			2.8 ⁽¹⁾	W

Note:

1. Typical thermal resistance when mounted on a four-layer, two-ounce PCB, as shown in Figure 26. Actual results are dependent on mounting method and surface related to the design.

Electrical Specifications

Electrical specifications are the result of using the circuit shown in Figure 1 with $V_{IN} = 12\text{ V}$, unless otherwise noted.

Parameter	Conditions	Min.	Typ.	Max.	Unit
Power Supplies					
V_{CC} Current	SW = Open, FB = 0.7 V, $V_{CC} = 5\text{ V}$, $f_{SW} = 600\text{ KHz}$		8	12	mA
	Shutdown: EN = 0, $V_{CC} = 5\text{ V}$		7	10	μA
V_{CC} UVLO Threshold	Rising V_{CC}	4.1	4.3	4.5	V
	Hysteresis		300		mV
Oscillator					
Frequency	$R_T = 50\text{ K}\Omega$	255	300	345	KHz
	$R_T = 24\text{ K}\Omega$	540	600	660	KHz
Minimum On-Time ⁽²⁾			50	65	ns
Ramp Amplitude, Peak-to-Peak	16 V_{IN} , 1.8 V_{OUT} , $R_T = 30\text{ K}\Omega$, $R_{RAMP} = 200\text{ K}\Omega$		0.53		V
Minimum Off-Time ⁽²⁾			100	150	ns
Reference					
Reference Voltage (V_{FB}) ⁽³⁾		795	800	805	mV
Error Amplifier					
DC Gain ⁽²⁾	$V_{CC} = 5\text{ V}$	80	85		dB
Gain Bandwidth Product ⁽²⁾		12	15		MHz
Output Voltage (V_{COMP})		0.4		3.2	V
Output Current, Sourcing	$V_{CC} = 5\text{ V}$, $V_{COMP} = 2.2\text{ V}$	1.5	2.2		mA
Output Current, Sinking	$V_{CC} = 5\text{ V}$, $V_{COMP} = 1.2\text{ V}$	0.8	1.2		mA
FB Bias Current	$V_{FB} = 0.8\text{ V}$, $T_A = 25^\circ\text{C}$	-850	-650	-450	nA
Protection and Shutdown					
Current Limit	R_{LIM} Open, $f_{SW} = 500\text{ KHz}$, $V_{OUT} = 1.8\text{ V}$, $R_{RAMP} = 200\text{ K}\Omega$, 16 Consecutive Cycles	6	8	10	A
I_{LIM} Current	$V_{CC} = 5\text{ V}$, $T_A = 25^\circ\text{C}$	-11	-10	-9	μA
Over-Temperature Shutdown	Internal IC Temperature		+155		$^\circ\text{C}$
Over-Temperature Hysteresis			+30		$^\circ\text{C}$
Over-Voltage Threshold	2 Consecutive Clock Cycles	110	115	120	% V_{OUT}
Under-Voltage Shutdown	16 Consecutive Clock Cycles	68	73	78	% V_{OUT}
Fault Discharge Threshold	Measured at FB Pin		250		mV
Fault Discharge Hysteresis	Measured at FB Pin ($V_{FB} \sim 500\text{ mV}$)		250		mV
Soft-Start					
V_{OUT} to Regulation (T0.8)	Frequency = 600 KHz		5.3		ms
Fault Enable/SSOK (T1.0)			6.7		ms

Continued on the following page...

Electrical Specifications (Continued)

Electrical specifications are the result of using the circuit shown in Figure 1 with $V_{IN} = 12\text{ V}$, unless otherwise noted.

Parameter	Conditions	Min.	Typ.	Max.	Unit
Control Functions					
EN Threshold, Rising	$V_{CC} = 5\text{ V}$		1.35	2.00	V
EN Hysteresis	$V_{CC} = 5\text{ V}$		250		mV
EN Pull-Up Resistance	$V_{CC} = 5\text{ V}$		800		$\text{K}\Omega$
EN Discharge Current	Auto-Restart Mode, $V_{CC} = 5\text{ V}$		1		μA
FB OK Drive Resistance				800	Ω
PGOOD Threshold (Compared to V_{REF})	$\text{FB} < V_{REF}$, 2 Consecutive Clock Cycles	-14	-11	-8	$\%V_{REF}$
	$\text{FB} > V_{REF}$, 2 Consecutive Clock Cycles	+7	+10	+13	$\%V_{REF}$
PGOOD Output Low	$I_{OUT} \leq 2\text{ mA}$			0.4	V

Notes:

- Specifications guaranteed by design and characterization; not production tested.
- See Figure 4 for Temperature Coefficient

Typical Characteristics

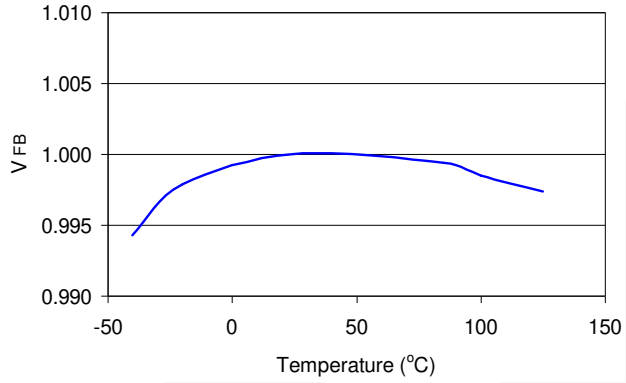

Figure 4. Reference Voltage (V_{FB}) vs. Temperature, Normalized

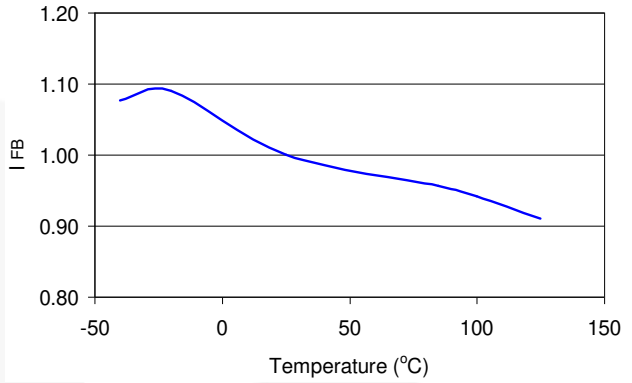

Figure 5. Reference Bias Current (I_{FB}) vs. Temperature, Normalized

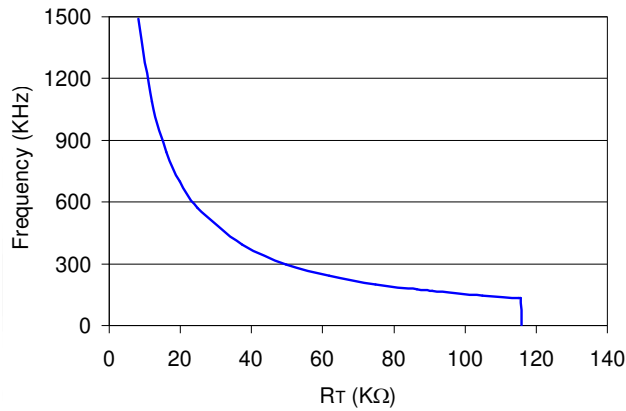

Figure 6. Frequency vs. R_T

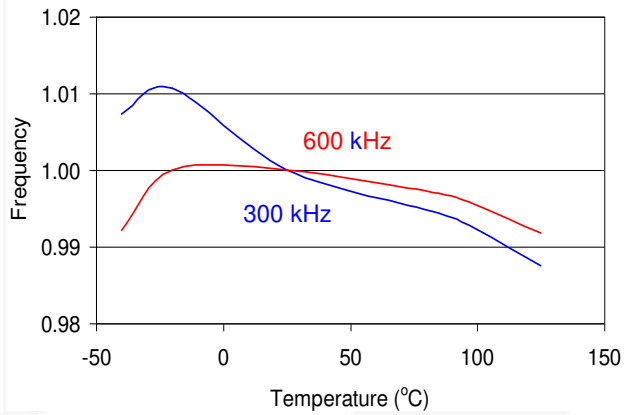

Figure 7. Frequency vs. Temperature, Normalized

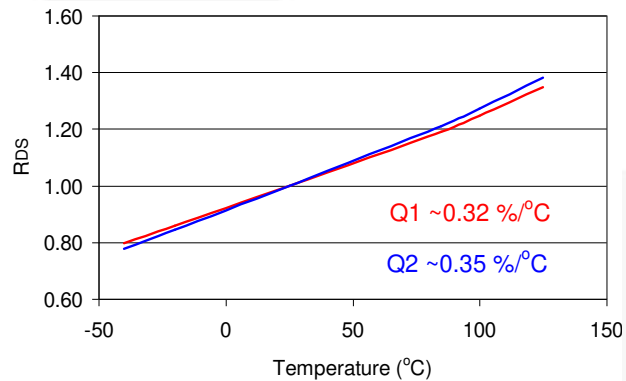

Figure 8. R_{DS} vs. Temperature, Normalized ($V_{CC} = V_{GS} = 5\text{ V}$)

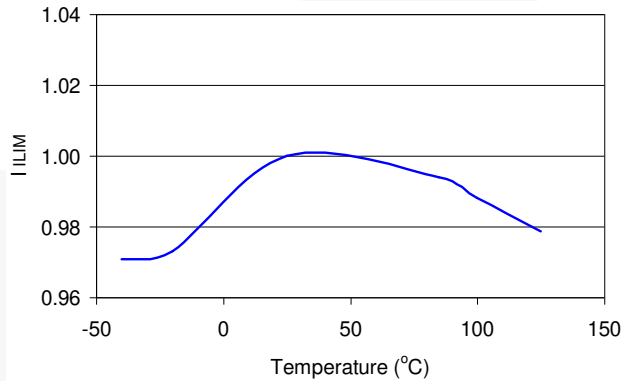

Figure 9. I_{LIM} Current (I_{LIM}) vs. Temperature, Normalized

Application Circuit

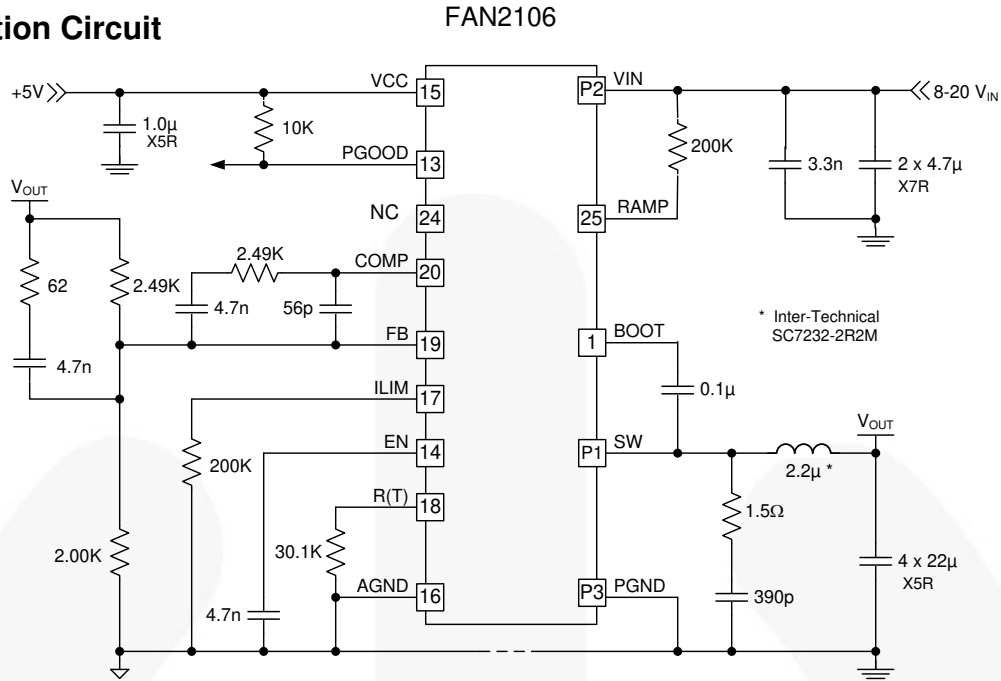

Figure 10. Application Circuit: 1.8 V_{OUT}, 500 KHz

Typical Performance Characteristics

Typical operating characteristics using the circuit shown in Figure 10. V_{IN}=12 V, V_{CC}=5 V, unless otherwise specified.

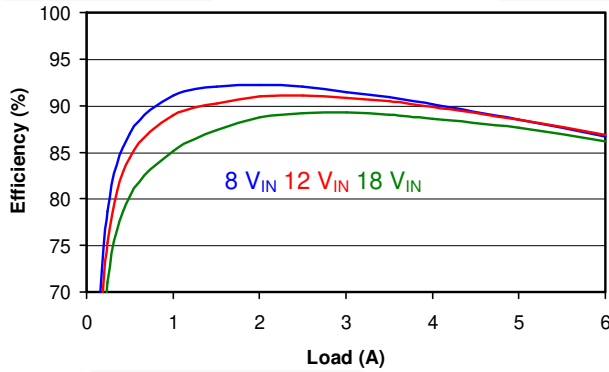

Figure 11. 1.8 V_{OUT} Efficiency Over V_{IN} vs. Load

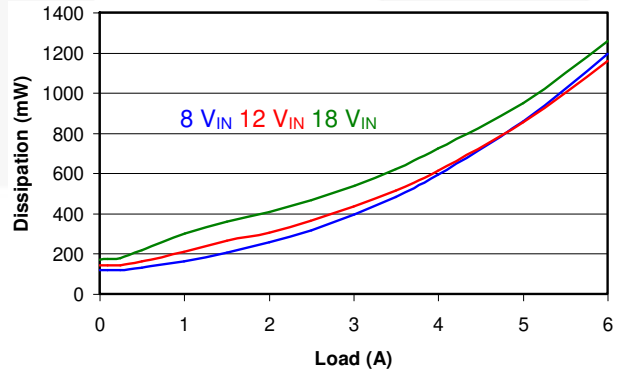

Figure 12. 1.8 V_{OUT} Dissipation Over V_{IN} vs. Load

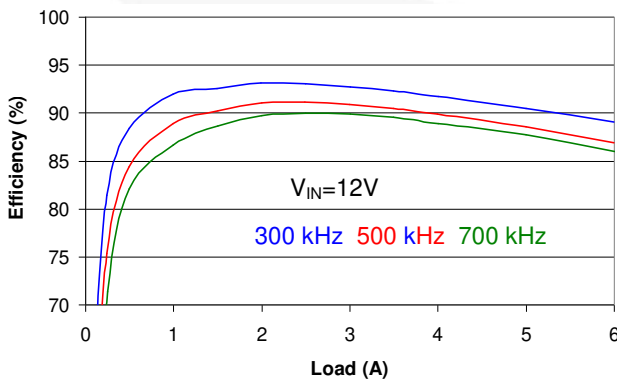

Figure 13. 1.8 V_{OUT} Efficiency Over Frequency vs. Load (Circuit Value Changes)

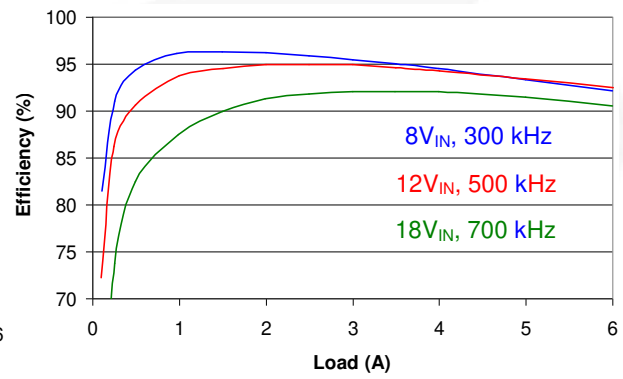

Figure 14. 3.3 V_{OUT} Efficiency vs. Load (Circuit Value Changes)

Typical Performance Characteristics (Continued)

Typical operating characteristics using the circuit shown in Figure 10. $V_{IN}=12\text{ V}$, $V_{CC}=5\text{ V}$, unless otherwise specified.

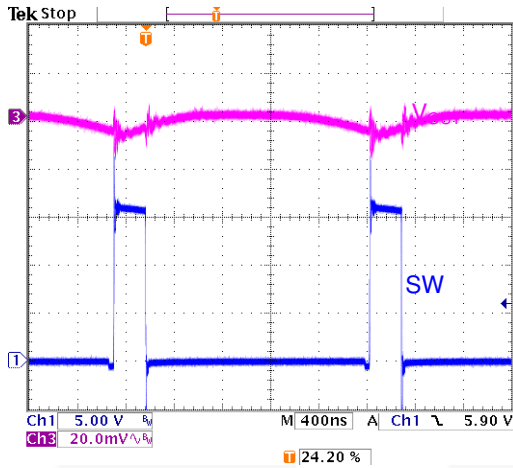

Figure 15. SW and V_{OUT} Ripple, 6 A Load

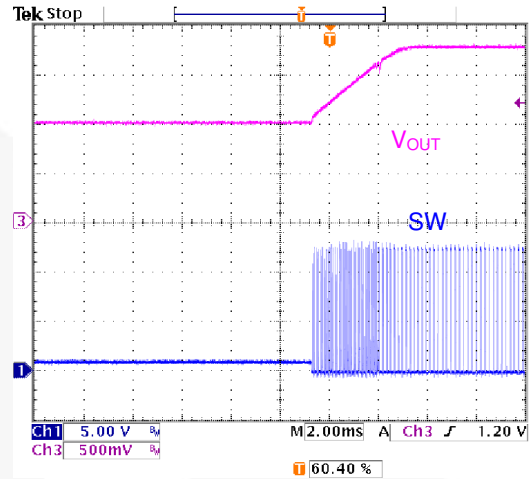

Figure 16. Startup with 1 V Pre-Bias on V_{OUT}

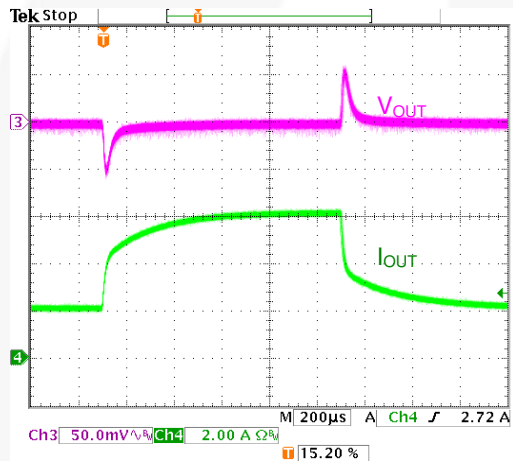

Figure 17. Transient Response, 2-6 A Load

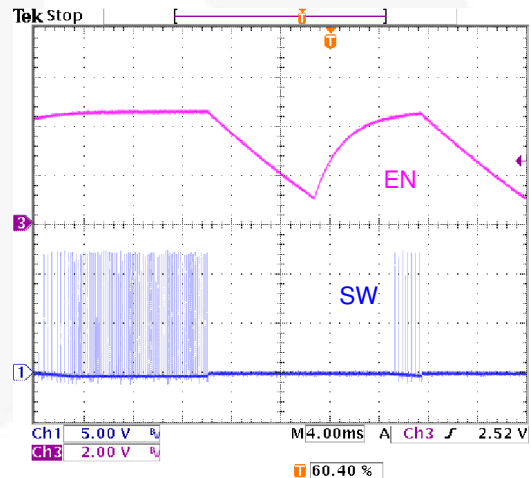

Figure 18. Re-Start on Fault

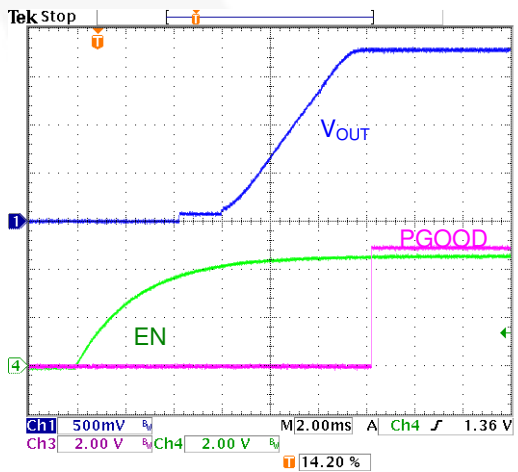

Figure 19. Startup, 3 A Load

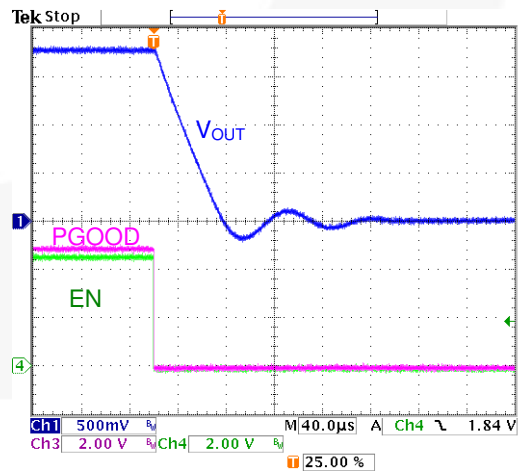

Figure 20. Shutdown, 3 A Load

Circuit Description

PWM Generation

Refer to Figure 2 for the PWM control mechanism. FAN2106 uses the summing-mode method of control to generate the PWM pulses. An amplified current-sense signal is summed with an internally generated ramp and the combined signal is compared with the output of the error amplifier to generate the pulsewidth to drive the high-side MOSFET. Sensed current from the previous cycle is used to modulate the output of the summing block. The output of the summing block is also compared against a voltage threshold set by the R_{LIM} resistor to limit the inductor current on a cycle-by-cycle basis. The R_{RAMP} resistor helps set the charging current for the internal ramp and provides input voltage feed-forward function. The controller facilitates external compensation for enhanced flexibility.

Initialization

Once V_{CC} exceeds the UVLO threshold and EN is HIGH, the IC checks for a shorted FB pin before releasing the internal soft-start ramp (SS).

If the parallel combination of R1 and R_{BIAS} is $\leq 1\text{ K}\Omega$, the internal SS ramp is not released and the regulator does not start.

Enable

FAN2106 has an internal pull-up to the ENABLE (EN) pin so that the IC is enabled once V_{CC} exceeds the UVLO threshold. Connecting a small capacitor across EN and AGND delays the rate of voltage rise on the EN pin. The EN pin also serves for the restart whenever a fault occurs (refer to the *Auto-Restart* section). If the regulator is enabled externally, the external EN signal should go HIGH only after V_{CC} is established. For applications where such sequencing is required, FAN2106 can be enabled (after the V_{CC} comes up) with external control, as shown in Figure 21.

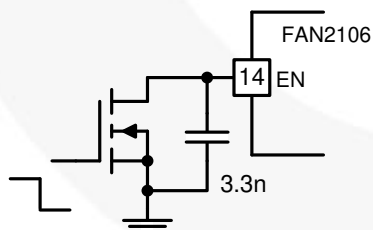

Figure 21. Enabling with External Control

Soft-Start

Once internal SS ramp has charged to 0.8 V ($T_{0.8}$), the output voltage is in regulation. Until SS ramp reaches 1.0 V ($T_{1.0}$), the fault latch is inhibited.

To avoid skipping the soft-start cycle, it is necessary to apply V_{IN} before V_{CC} reaches its UVLO threshold. Normal sequence for powering up would be $V_{IN} \rightarrow V_{CC} \rightarrow EN$.

Soft-start time is a function of switching frequency.

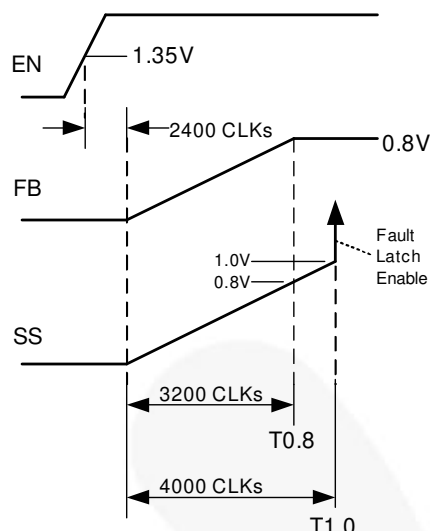

Figure 22. Soft-Start Timing Diagram

Cycling V_{CC} or the EN pin discharges the internal SS and resets the IC. In applications where external EN signal is used, V_{IN} and V_{CC} should be established before the EN signal comes up to prevent skipping the soft-start function.

Startup on Pre-Bias

The regulator does not allow the low-side MOSFET to operate in full synchronous rectification mode until internal SS ramp reaches 95% of V_{REF} ($\sim 0.76\text{ V}$). This helps the regulator start on a pre-biased output and ensures that the pre-biased outputs are not discharged during soft-start.

Protections

The converter output is monitored and protected against extreme overload, short-circuit, over-voltage, under-voltage, and over-temperature conditions.

Under-Voltage Shutdown

If the voltage on the FB pin remains below the under-voltage threshold for 16 consecutive clock cycles, the fault latch is set and the converter shuts down. This protection is not active until the internal SS ramp reaches 1.0 V during soft-start.

Over-Voltage Protection

If voltage on the FB pin exceeds 115% of V_{REF} for two consecutive clock cycles, the fault latch is set and shutdown occurs.

A shorted high-side MOSFET condition is detected when SW voltage exceeds $\sim 0.7\text{ V}$ while the low-side

MOSFET is fully enhanced. The fault latch is set immediately upon detection.

The OV and high-side short fault protections are active all the time, including during soft-start.

Over-Temperature Protection (OTP)

The chip incorporates an over-temperature protection circuit that sets the fault latch when a die temperature of about 150°C is reached. The IC restarts when the die temperature falls below 125°C.

Auto-Restart

After a fault, EN pin is discharged by a 1 μA current sink to a 1.1 V threshold before the internal 800 KΩ pull-up is restored. A new soft-start cycle begins when EN charges above 1.35 V.

Depending on the external circuit, the FAN2106 can be configured to remain latched-off or to automatically restart after a fault.

Table 1. Fault / Restart Configurations

EN Pin	Controller / Restart State
Pull to GND	OFF (Disabled)
Pull-up to V _{CC} with 100 K	No Restart – Latched OFF (After V _{CC} Comes Up)
Open	Immediate Restart After Fault
Cap. to GND	New Soft-Start Cycle After: t _{DELAY} (ms)=3.9 • C(nf)

When EN is left open, restart is immediate.

If auto-restart is not desired, tie the EN pin to the V_{CC} pin or pull it HIGH after V_{CC} comes up with a logic gate to keep the 1 μA current sink from discharging EN to 1.1 V. Figure 23 shows one method to pull up EN to V_{CC} for a latch configuration.

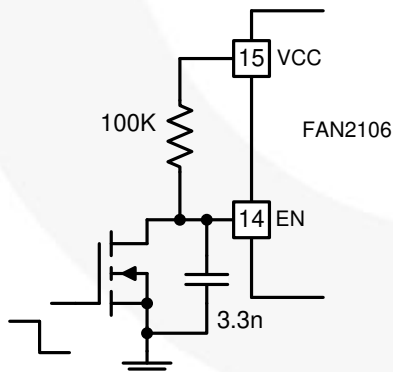

Figure 23. Enable Control with Latch Option

Power-Good (PGOOD) Signal

PGOOD is an open-drain output that asserts LOW when V_{OUT} is out of regulation, as measured at the FB pin. Thresholds are specified in the Electrical Specifications section. PGOOD does not assert HIGH until the fault latch is enabled (T1.0) (see Figure 22).

Application Information

Bias Supply

The FAN2106 requires a 5 V supply rail to bias the IC and provide gate-drive energy. Connect a ≥ 1.0 μf X5R or X7R decoupling capacitor between V_{CC} and PGND.

Since V_{CC} is used to drive the internal MOSFET gates, supply current is frequency and voltage dependent. Approximate V_{CC} current (I_{CC}) can be calculated using:

$$I_{CC(mA)} = 4.58 + \left[\left(\frac{V_{CC} - 5}{227} + 0.013 \right) \cdot (f - 128) \right] \quad (1)$$

where frequency (f) is expressed in KHz.

Setting the Output Voltage

The output voltage of the regulator can be set from 0.8 V to 80% of V_{IN} by an external resistor divider (R1 and R_{BIAS} in Figure 1). For output voltages > 5 V, output current rating may need to be de-rated depending upon the ambient temperature, power dissipated in the package and the PCB layout.

The external resistor divider is calculated using:

$$\frac{0.8V}{R_{BIAS}} = \frac{V_{OUT} - 0.8V}{R1} + 650nA \quad (2)$$

Connect R_{BIAS} between FB and AGND.

If R1 is open (see Figure 1), the output voltage is not regulated eventually causing a latched fault after the soft start is complete (T1.0)

If the parallel combination of R1 and R_{BIAS} is ≤ 1KΩ, the internal SS ramp is not released and the regulator does not start.

Setting the Switching Frequency

Switching frequency is determined by an external resistor, R_T, connected between the R(T) pin and AGND:

$$R_{T(K\Omega)} = \frac{(10^6 / f) - 135}{65} \quad (3)$$

where R_T is in KΩ and frequency (f) is in KHz.

The regulator cannot start if R_T is left open.

Calculating the Inductor Value

Typically the inductor value is chosen based on ripple current (ΔI_L), which is chosen between 10 to 35% of the maximum DC load. Regulator designs that require fast transient response use a higher ripple-current setting, while regulator designs that require higher efficiency keep ripple current on the low side and operate at a lower switching frequency. The inductor value is calculated by the following formula:

$$\Delta I_L = \frac{V_{OUT} \cdot (1 - D)}{L \cdot f} \quad (4)$$

where f is the switching frequency.

Setting the Ramp Resistor Value

R_{RAMP} resistor plays a critical role in the design by providing charging current to the internal ramp capacitor and also serving as a means to provide input voltage feedforward.

R_{RAMP} is calculated by the following formula:

$$R_{RAMP(K\Omega)} = \frac{(V_{IN} - 1.8) \cdot V_{OUT}}{(18) \cdot V_{IN} \cdot f \cdot 10^{-6}} - 2 \quad (5)$$

where frequency (f) is expressed in KHz.

For wide input operation, first calculate R_{RAMP} for the minimum and maximum input voltage conditions and use larger of the two values calculated.

In all applications, current through the R_{RAMP} pin must be greater than $10 \mu A$ from the equation below for proper operation:

$$\frac{V_{IN} - 1.8}{R_{RAMP} + 2} \geq 10 \mu A \quad (6)$$

If the calculated R_{RAMP} values in Equation (5) result in a current less than $10 \mu A$, use the R_{RAMP} value that satisfies Equation (6). In applications with large input ripple voltage, the R_{RAMP} resistor should be adequately decoupled from the input voltage to minimize ripple on the RAMP pin.

Setting the Current Limit

The current limit system involves two comparators. The MAX I_{LIMIT} comparator is used with a V_{ILIM} fixed-voltage reference and represents the maximum current limit allowable. This reference voltage is temperature compensated to reflect the R_{DSON} variation of the low-side MOSFET. The ADJUST I_{LIMIT} comparator is used where the current limit needs to be set lower than the V_{ILIM} fixed reference. The $10 \mu A$ current source does not track the R_{DSON} changes over temperature, so change is added into the equations for calculating the ADJUST I_{LIMIT} comparator reference voltage, as is shown below. Figure 24 shows a simplified schematic of the over-current system.

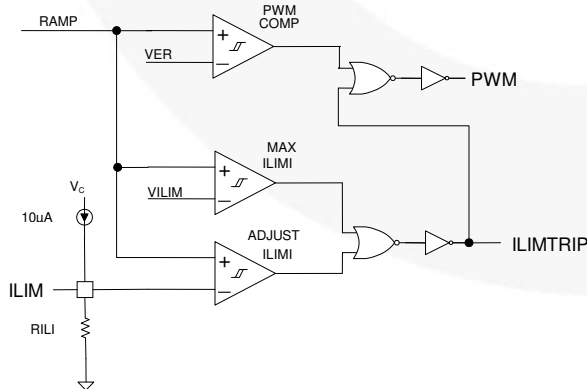

Figure 24. Current-Limit System Schematic

Since the I_{LIM} voltage is set by a $10 \mu A$ current source into the R_{ILIM} resistor, the basic equation for setting the reference voltage is:

$$V_{RILIM} = 10 \mu A \cdot R_{ILIM} \quad (7)$$

To calculate R_{ILIM} :

$$R_{ILIM} = V_{RILIM} / 10 \mu A \quad (8)$$

The voltage V_{RILIM} is made up of two components, V_{BOT} (which relates to the current through the low-side MOSFET) and V_{RMPEAK} (which relates to the peak current through the inductor). Combining those two voltage terms results in:

$$R_{ILIM} = (V_{BOT} + V_{RMPEAK}) / 10 \mu A \quad (9)$$

$$R_{ILIM} = \{0.96 + (I_{LOAD} \cdot R_{DSON} \cdot K_T \cdot 8)\} + \{D \cdot (V_{IN} - 1.8) / (f_{SW} \cdot 0.03 \cdot 10^{-3} \cdot R_{RAMP})\} / 10 \mu A \quad (10)$$

where:

$$V_{BOT} = 0.96 + (I_{LOAD} \cdot R_{DSON} \cdot K_T \cdot 8);$$

$$V_{RMPEAK} = D \cdot (V_{IN} - 1.8) / (f_{SW} \cdot 0.03 \cdot 10^{-3} \cdot R_{RAMP});$$

I_{LOAD} = the desired maximum load current;

R_{DSON} = the nominal R_{DSON} of the low-side MOSFET;

K_T = the normalized temperature coefficient for the low-side MOSFET (on datasheet graph);

D = V_{OUT} / V_{IN} duty cycle;

f_{SW} = Clock frequency in kHz; and

R_{RAMP} = chosen ramp resistor value in $k\Omega$.

After 16 consecutive, pulse-by-pulse, current-limit cycles, the fault latch is set and the regulator shuts down. Cycling V_{CC} or EN restores operation after a normal soft-start cycle (refer to the Auto-Restart section).

The over-current protection fault latch is active during the soft-start cycle. Use 1% resistor for R_{ILIM} .

Loop Compensation

The loop is compensated using a feedback network around the error amplifier. Figure 25 shows a complete Type-3 compensation network. For Type-2 compensation, eliminate R3 and C3.

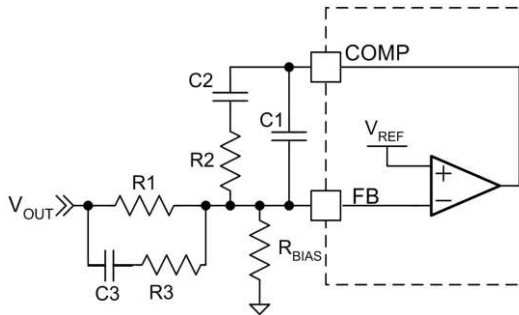

Figure 25. Compensation Network

Since the FAN2106 employs a summing current-mode architecture, Type-2 compensation can be used for many applications. For applications that require wide loop bandwidth and/or use very low-ESR output capacitors, Type-3 compensation may be required.

R_{RAMP} also provides feedforward compensation for changes in V_{IN} . With a fixed R_{RAMP} value, the modulator gain increases as V_{IN} is reduced; this could make it difficult to compensate the loop. For low-input-voltage-range designs (3 V to 8 V), R_{RAMP} and the compensation component values are different compared to designs with V_{IN} between 8 V and 24 V.

Application note [AN-8022 \(TinyCalc™\)](#) can be used to calculate the compensation components.

Recommended PCB Layout

Good PCB layout and careful attention to temperature rise is essential for reliable operation of the regulator. Four-layer PCB with two-ounce copper on the top and bottom sides and thermal vias connecting the layers are recommended. Keep power traces wide and short to minimize losses and ringing. Do not connect AGND to PGND below the IC. Connect the AGND pin to PGND at the output OR to the PGND plane.

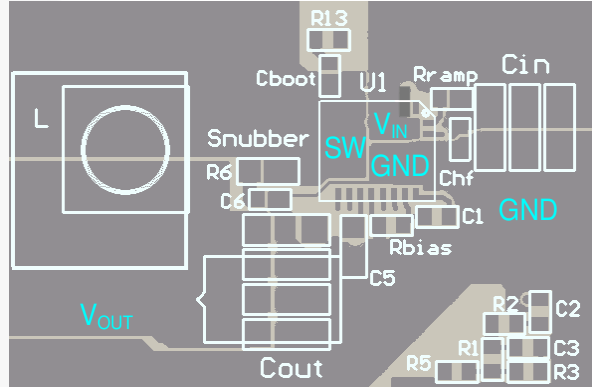
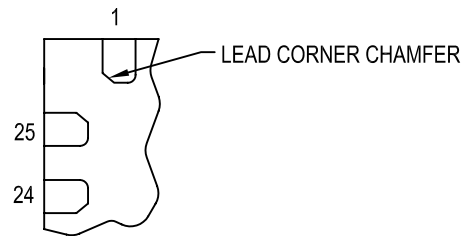
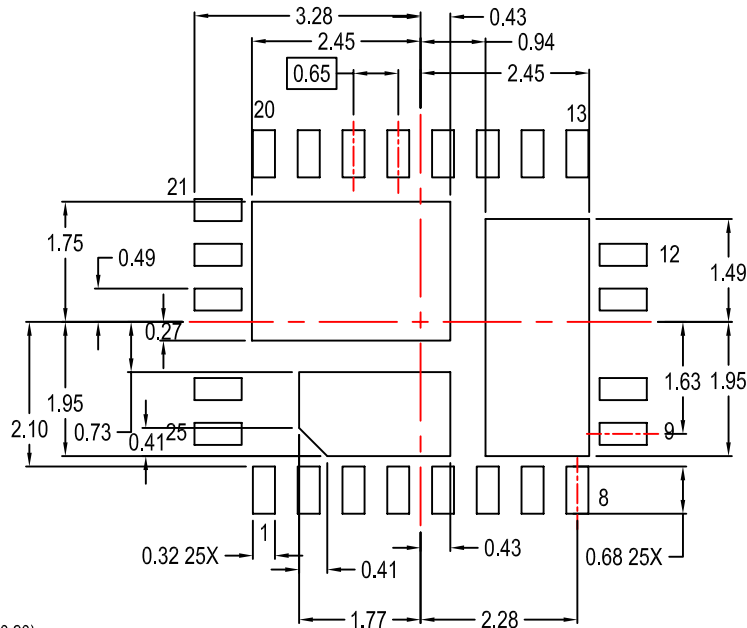
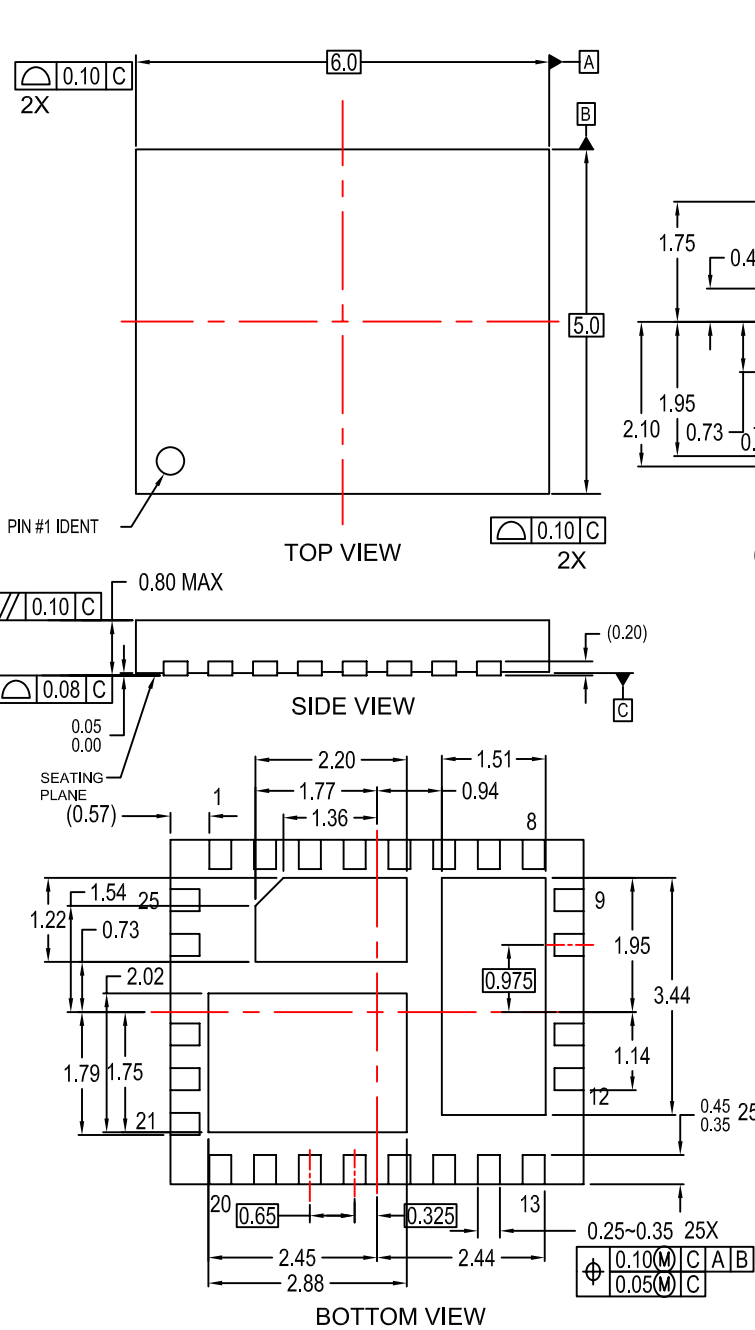

Figure 26. Recommended PCB Layout

REVISIONS			
LTR	DESCRIPTION	DATE	BY/SITE
1	RELEASE TO DOCUMENT CONTROL	12-Jul-2007	J.Chan/FSPM
2	ADDED DIMENSIONS TO BOTTOM VIEW AND LANDPATTERN RECOMMENDATION	7-SEPT-2007	H.ALLEN/FSME
3	CHAMFERED LANDPATTERN PAD 1	17-JUN-2009	H.ALLEN/FSME



NOTES: UNLESS OTHERWISE SPECIFIED

- A) DIMENSIONS ARE IN MILLIMETERS.
- B) DIMENSIONS AND TOLERANCES PER ASME Y14.5M, 1994
- C) DIMENSIONS DO NOT INCLUDE MOLD FLASH OR BURRS.
- D) DESIGN BASED ON JEDEC MO-220 VARIATION WJHC
- E) TERMINALS ARE SYMMETRICAL AROUND THE X & Y AXIS EXCEPT WHERE DEPOPULATED.
- F) DRAWING FILENAME: MKT-MLP25AREV3

APPROVALS		DATE	Bayan Lepas, FIZ, 11900, Penang, Malaysia.		
DRAWN	H.ALLEN	7-SEPT-07			
DFTG. CHK.	S.MARTIN	7-SEPT-07			
ENGR. CHK.					
25LD, MLP, QUAD, NON-JEDEC, 6x5MM TRIPLE DAP					
		SCALE	SIZE	DRAWING NUMBER	REV
		N/A	N/A	MKT-MLP25A	3
DO NOT SCALE DRAWING				SHEET 1 of 1	

ON Semiconductor and  are trademarks of Semiconductor Components Industries, LLC dba ON Semiconductor or its subsidiaries in the United States and/or other countries. ON Semiconductor owns the rights to a number of patents, trademarks, copyrights, trade secrets, and other intellectual property. A listing of ON Semiconductor's product/patent coverage may be accessed at www.onsemi.com/site/pdf/Patent-Marking.pdf. ON Semiconductor reserves the right to make changes without further notice to any products herein. ON Semiconductor makes no warranty, representation or guarantee regarding the suitability of its products for any particular purpose, nor does ON Semiconductor assume any liability arising out of the application or use of any product or circuit, and specifically disclaims any and all liability, including without limitation special, consequential or incidental damages. Buyer is responsible for its products and applications using ON Semiconductor products, including compliance with all laws, regulations and safety requirements or standards, regardless of any support or applications information provided by ON Semiconductor. "Typical" parameters which may be provided in ON Semiconductor data sheets and/or specifications can and do vary in different applications and actual performance may vary over time. All operating parameters, including "Typicals" must be validated for each customer application by customer's technical experts. ON Semiconductor does not convey any license under its patent rights nor the rights of others. ON Semiconductor products are not designed, intended, or authorized for use as a critical component in life support systems or any FDA Class 3 medical devices or medical devices with a same or similar classification in a foreign jurisdiction or any devices intended for implantation in the human body. Should Buyer purchase or use ON Semiconductor products for any such unintended or unauthorized application, Buyer shall indemnify and hold ON Semiconductor and its officers, employees, subsidiaries, affiliates, and distributors harmless against all claims, costs, damages, and expenses, and reasonable attorney fees arising out of, directly or indirectly, any claim of personal injury or death associated with such unintended or unauthorized use, even if such claim alleges that ON Semiconductor was negligent regarding the design or manufacture of the part. ON Semiconductor is an Equal Opportunity/Affirmative Action Employer. This literature is subject to all applicable copyright laws and is not for resale in any manner.

PUBLICATION ORDERING INFORMATION

LITERATURE FULFILLMENT:

Literature Distribution Center for ON Semiconductor
19521 E. 32nd Pkwy, Aurora, Colorado 80011 USA
Phone: 303-675-2175 or 800-344-3860 Toll Free USA/Canada
Fax: 303-675-2176 or 800-344-3867 Toll Free USA/Canada
Email: orderlit@onsemi.com

N. American Technical Support: 800-282-9855 Toll Free
USA/Canada
Europe, Middle East and Africa Technical Support:
Phone: 421 33 790 2910
Japan Customer Focus Center
Phone: 81-3-5817-1050

ON Semiconductor Website: www.onsemi.com
Order Literature: <http://www.onsemi.com/orderlit>
For additional information, please contact your local
Sales Representative