



Chipsmall Limited consists of a professional team with an average of over 10 year of expertise in the distribution of electronic components. Based in Hongkong, we have already established firm and mutual-benefit business relationships with customers from,Europe,America and south Asia,supplying obsolete and hard-to-find components to meet their specific needs.

With the principle of “Quality Parts,Customers Priority,Honest Operation,and Considerate Service”,our business mainly focus on the distribution of electronic components. Line cards we deal with include Microchip,ALPS,ROHM,Xilinx,Pulse,ON,Everlight and Freescale. Main products comprise IC,Modules,Potentiometer,IC Socket,Relay,Connector.Our parts cover such applications as commercial,industrial, and automotives areas.

We are looking forward to setting up business relationship with you and hope to provide you with the best service and solution. Let us make a better world for our industry!



Contact us

Tel: +86-755-8981 8866 Fax: +86-755-8427 6832

Email & Skype: info@chipsmall.com Web: www.chipsmall.com

Address: A1208, Overseas Decoration Building, #122 Zhenhua RD., Futian, Shenzhen, China



FAN3800 — Mono / Stereo Audio Amplifier with Microphone Pre-Amplifier and EMU Interface

Features

- Regulated positive supply
- Negative supply generator allows ground-centered output swing
- Dual speaker drivers with mono/stereo switch capability
- Capable of driving 16mW_{RMS} per channel
- Complete external microphone interface
- Enhanced mini-USB bus detection and interface circuitry
- Manual and remote send-end switch interface
- Pop and click suppression
- Single 2.7V to 4.5V operation
- 2kV ESD (HBM) protection
- MLP 24-pin package

Applications

- One-piece stereo/mono headset with microphone
- EMU to 3.5mm stereo headphone adapter
- EMU to 2.5 or 3.5 adapter for stereo headset with microphone

Description

The FAN3800 is a low-cost solution that integrates the many discrete parts currently used in stereo headset applications. It provides mono / stereo speaker drivers and a complete microphone interface. Additionally, the FAN3800 allows headset detection and identification through a 5-pin, enhanced mini-USB (EMU) bus. Manual and remote send-end switching is supported.

The FAN3800 speaker drivers are designed to operate with a ground-centered output signal. This allows removal of large and expensive DC blocking capacitors. In addition, it allows interfacing with externally powered speakers. The speaker drivers are capable of driving up to 16mW_{RMS} per channel.

FAN3800 delivers a complete solution for interfacing an external microphone. The microphone interface provides a regulated, high PSRR supply, differential input sense to single-ended output driver amplifiers, and output muting. Gain is fixed at 36dB and can be attenuated externally with a resistor divider network.

Send-end switching automatically routes the microphone output to the D+ output. When activated, the speakers switch from stereo to mono mode, both driven by the D- input. Pop and click noise is minimized during switching. Send-end information can be generated manually through an external switch or through the EMU bus interface.

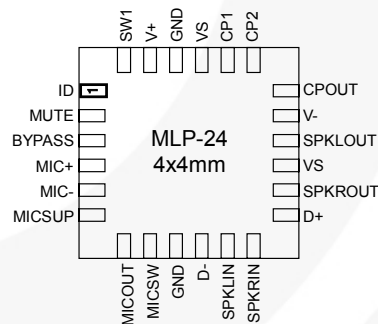

Figure 1. FAN3800 Pin Out

Ordering Information

Part Number	Pb-Free	Package	Packing Method
FAN3800MLP24X		24-Pin Molded Leadless Package (MLP)	Pack

Block Diagram

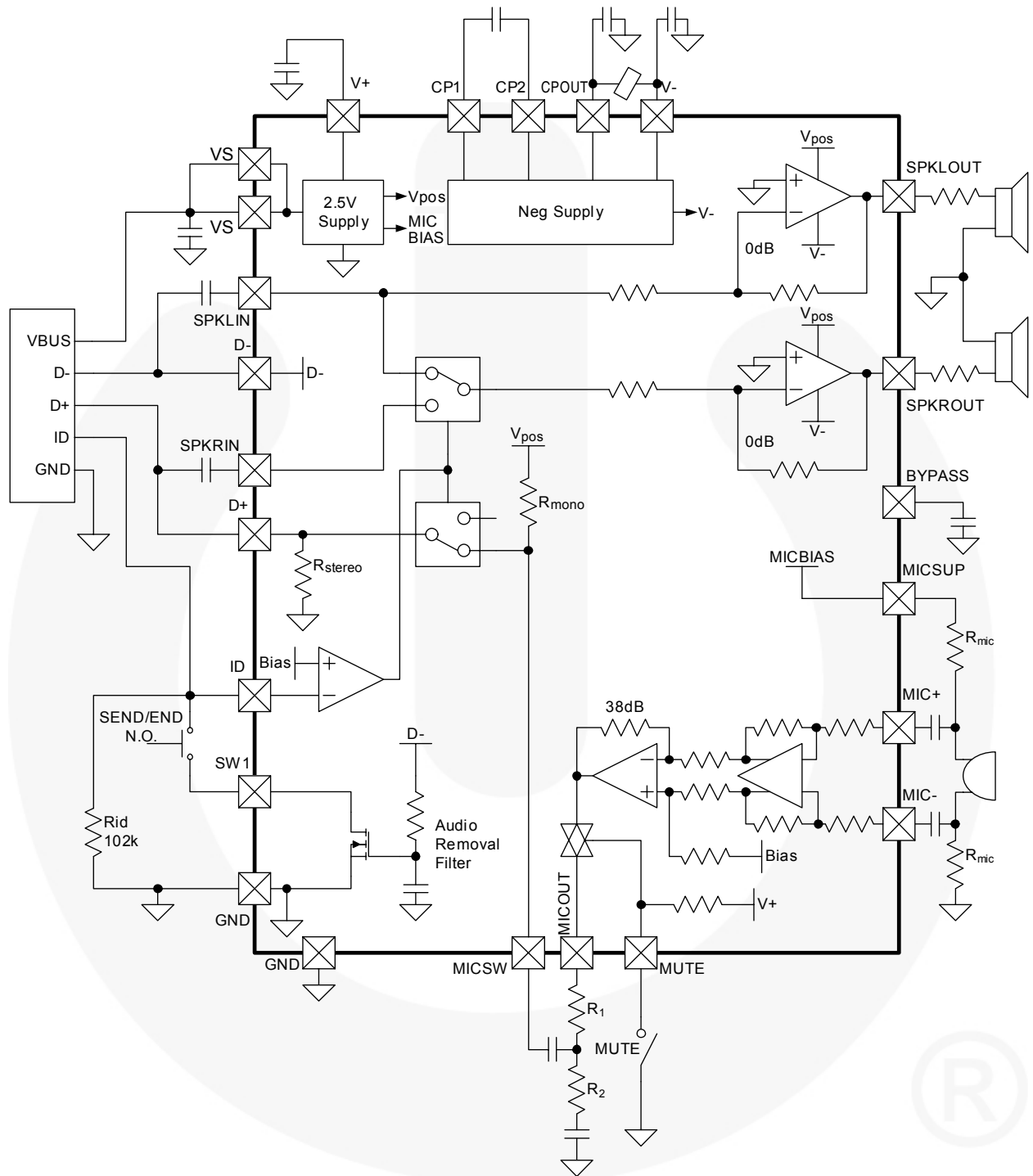

Figure 2. Block Diagram

Pin Assignments

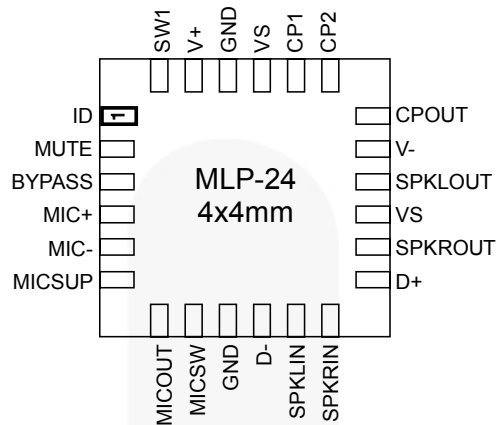

Figure 3. FAN3800 Pin Out

Pin Definitions

Pin #	Name	Type	Description
1	ID	Input	Identification pin
2	MUTE	Input	Microphone mute control input
3	BYPASS	Output	External 100nF capacitor used for pop/click suppression
4	MIC+	Input	High-side differential MIC input
5	MIC-	Input	Low-side differential MIC input
6	MICSUP	Output	Microphone supply pin
7	MICOUT	Output	Microphone amplifier output tap for setting gain and shifting the DC bias level
8	MICSW	Input	Output of microphone amplifier AC coupled to the D+ switch
9	GND	Input	IC ground
10	D-	Input	DC biased EMU bus input for send-end enable
13	D+	Input	DC biased EMU bus input for identification
		Output	Driven by MICOUT in mono mode
14	SPKROUT	Output	Right speaker driver output
15	VS	Input	Supply input from host device (3.3V typical)
16	SPKLOUT	Output	Left speaker driver output
17	V-	Input	Filtered negative supply driven by CPOUT
18	CPOUT	Output	Charge pump unfiltered output
19	CP2	I/O	Charge pump external cap pin
20	CP1	I/O	Charge pump external cap pin
21	VS	Input	Supply input from host device (3.3V typical)
22	GND	Input	IC ground
23	V+	Output	Positive power supply output for decoupling capacitor
24	SW1	Input	Send-end switch input

Absolute Maximum Ratings

Stresses exceeding the absolute maximum ratings may damage the device. The device may not function or be operable above the recommended operating conditions and stressing the parts to these levels is not recommended. In addition, extended exposure to stresses above the recommended operating conditions may affect device reliability. The absolute maximum ratings are stress ratings only.

Symbol	Parameter	Min.	Max.	Unit
V_S	Supply Voltage	-0.3	+6.0	V
$V_{I/O}$	Analog and Digital I/O	GND-0.3	$V_{CC}+0.3$	V
T_J	Junction Temperature		+150	°C
T_{STG}	Storage Temperature Range	-40	+80	°C
T_L	Lead Temperature (Soldering, 10 seconds)		+240	°C

Recommended Operating Conditions

The Recommended Operating Conditions table defines the conditions for actual device operation. Recommended operating conditions are specified to ensure optimal performance to the datasheet specifications. Fairchild does not recommend exceeding them or designing to Absolute Maximum Ratings.

Symbol	Parameter	Min.	Typ.	Max.	Unit
V_S	Supply Voltage	2.7	3.3	4.5	V
T_A	Temperature Range	-20	27	60	°C
Z_{LOAD}	Speaker Load Impedance	14	32		Ω
$V_{IN\ D+/D-}$	D+,D- ,SPKLIN,SPKRIN Input Range	0		V_S	V
$V_{BIAS\ D+/D}$	D- / D+ Bias Level in Audio Mode	1.25	1.39	1.53	V
Θ_{JA}	Package Thermal Resistance, JEDEC Standard Multi-Layer Boards, Still Air		40		°C/W

Electrical Characteristics

$T_A = 25^\circ\text{C}$, $V_S = 3.0\text{V}$, audio inputs at -6dBV and AC coupled with $1\mu\text{F}$, speaker outputs DC coupled into 16Ω loads referenced to 1kHz , $I_D = V_{IL}$, $C_{\text{BYPASS}} = 100\text{nF}$, unless otherwise noted.

Symbol	Parameter	Conditions	Min.	Typ.	Max.	Units
Power Supply Characteristics						
I_S	Supply Current ⁽¹⁾	No load		5.6	6.0	mA
t_{SUPPLY}	Power-Up Stabilization Time	V+, V- within 90% of final value			10	ms
PSRR_{MIC}	Power Supply Noise Rejection at MIC Output	217Hz 12% duty cycle square wave 2.7V to 3.2V at V_S Output (D+) in V_{rms} as single wideband measurement within psophometric filter	-80			dBV(p)
$\text{PSRR}_{\text{SPKR}}$	Power Supply Noise Rejection at Speaker Output	217Hz 12% duty cycle square wave 2.7V to 3.2V at V_S Output (D+) in V_{rms} as single wideband noise measurement within 20Hz – 20kHz, A weighted	-80			dBV(a)
V_{MIC}	Microphone Bias Supply ⁽¹⁾	Supply current = 1mA	2.0	2.1	2.2	V
D+/D- Line Characteristics						
$V_{\text{OH D+}}$	Output High Voltage D+ ⁽¹⁾	During detection, mono mode (external $150\text{k} \pm 30\%$ D+ pull-up to 2.775V 3%)	2.0			V
$V_{\text{OL D+}}$	Output Low Voltage D+ ⁽¹⁾	During detection, stereo mode (external $150\text{k} \pm 30\%$ D+ pull-up to 2.775V 3%)			0.8	V
$V_{\text{OL D-}}$	Output Low Voltage D- ⁽¹⁾	During detection (external 4M pull-down to GND)			0.8	V
$V_{\text{EN LOW}}$	D- Voltage to Disable MFB ⁽¹⁾	Multi-function button disabled			0.5	V
$V_{\text{EN HIGH}}$	D- Voltage to Enable MFB ⁽¹⁾	Multi-function button enabled	1.0			V
ID Line Characteristics						
V_{OH}	Output High Voltage ⁽¹⁾	Send-end active, 102k Ω pull-down resistor	0.8			V
V_{OL}	Output Low Voltage ⁽¹⁾	Send -end Active, 102k Ω pull-down resistor			0.2	V
V_{IH}	Input High Voltage – Stereo Mode ⁽¹⁾	Voltage divider from phone and external 102k Ω pull-down resistors	1.4			V
V_{IL}	Input Low Voltage – Mono Mode ⁽¹⁾	Voltage divider from phone and external 102k Ω pull-down resistors			1.0	V
I_{IN}	Input Leakage Current ⁽²⁾	Send-end inactive			100	nA
Input/Output Impedance						
$Z_{\text{ID-}}$	D- Input Impedance ⁽¹⁾	D-, mono mode; D-, stereo mode	33			k Ω
$Z_{\text{ID+}}$	D+ Input Impedance ⁽¹⁾	D+, stereo mode	33			k Ω
$Z_{\text{OD+}}$	D+ Output Impedance ⁽²⁾	D+, mono mode			200	Ω
Z_{MICSUP}	MICSUP input Impedance ⁽²⁾	$V_S = 0$	200			k Ω
$Z_{\text{L D+}}$	Maximum Load Impedance on D+ ⁽²⁾	Mono mode			300	pF
$Z_{\text{L SPKR}}$	Maximum Load Impedance on SPKROUT & SPKLOUT ⁽²⁾	Stereo or mono mode			1	nF
Mute Input						
V_{IH}	Input High Voltage ⁽¹⁾	Mute-line floating	1.5			V
V_{IL}	Input Low Voltage ⁽¹⁾				0.8	V

Continued on the following page...

Electrical Characteristics (Continued)

$T_A = 25^\circ\text{C}$, $V_S = 3.0\text{V}$, audio inputs at -6dBV and AC coupled with $1\mu\text{F}$, speaker outputs DC coupled into 16Ω loads referenced to 1kHz , $I_D = V_{IL}$, $C_{\text{BYPASS}} = 100\text{nF}$, unless otherwise noted.

Symbol	Parameter	Conditions	Min.	Typ.	Max.	Units
Microphone Pre-Amplifier						
A_{MIC}	Gain ⁽¹⁾	1kHz, no divider on MICOUT, Input = -58dBV	37.5	38.0	38.5	dB
FR_{MIC}	Frequency Response ⁽¹⁾	Input = -58dBV , no divider on MICOUT, referenced to 1kHz	20Hz to 100Hz	-3.0	0.5	dB
			100Hz to 20kHz	-0.5	0.5	
THD_{MIC}	Distortion ⁽²⁾	Input = -44dBV at 1kHz Microphone output resistors, $R_1 = R_2 = 800\Omega$			-65	dB SINAD
$NOISE_{\text{MIC}}$	Idle Noise ⁽²⁾	Input loaded with 2Ω through $1\mu\text{F}$ cap. Psophometric weighted output			-80	dBVp
Speaker Amplifier						
A_{SPK}	Gain ⁽¹⁾	Input = -26dBV at 1kHz, 16Ω loads	-0.5	0	0.5	dB
FR_{SPK}	Frequency Response ⁽¹⁾	Input = -26dBV	20Hz to 15kHz referenced to 1kHz	-1.5	1.5	dB
			15kHz to 20kHz referenced to 1kHz	-0.5	0.5	
THD_{SPK}	Distortion ⁽²⁾	Input = -6dBV at 1kHz			-65	dB SINAD
$NOISE_{\text{SPK}}$	Idle Noise ⁽²⁾	No input			-75	dBV(A)
$XTLK_{\text{MS}}$	Microphone to Speaker Crosstalk ⁽²⁾	Input at microphone to give $D+ = -6\text{dBV}$, measure at speaker output			-65	dB
$XTLK_{\text{SM}}$	Speaker to Microphone Crosstalk ⁽²⁾	$D- = -6\text{dBV}$, measure at $D+$			-65	dB
A_{MATCH}	Matching of L & R Channels ⁽²⁾	Input = -26dBV , 20Hz to 20kHz			0.5	dB
$XTLK_{\text{SPK}}$	Crosstalk Between L & R Channel ⁽²⁾	Input = -26dBV			-65	dB

Notes:

- 100% tested at $T_A = 25^\circ\text{C}$.
- Guaranteed by design and characterization.
- Microphone path noise measured using psophometric weighting function (see Figure 4).
- Speaker path noise measured using A-type weighting.

Typical Characteristics

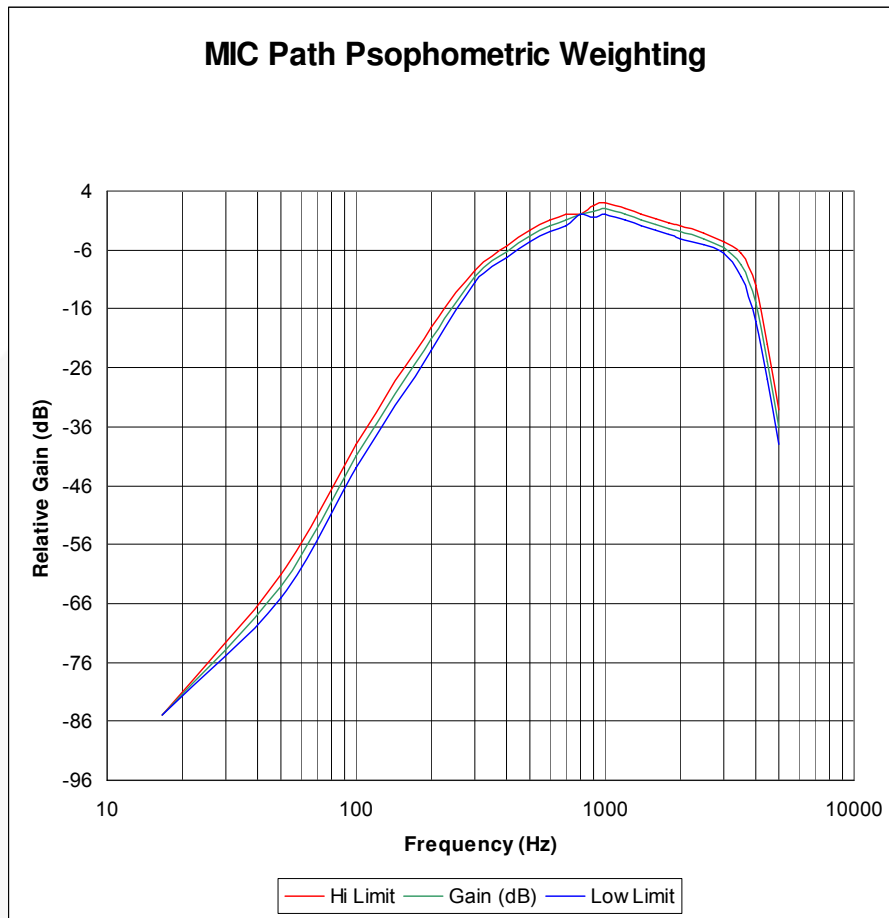

Figure 4. Microphone Path Psophometric Weighting Function

Physical Dimensions

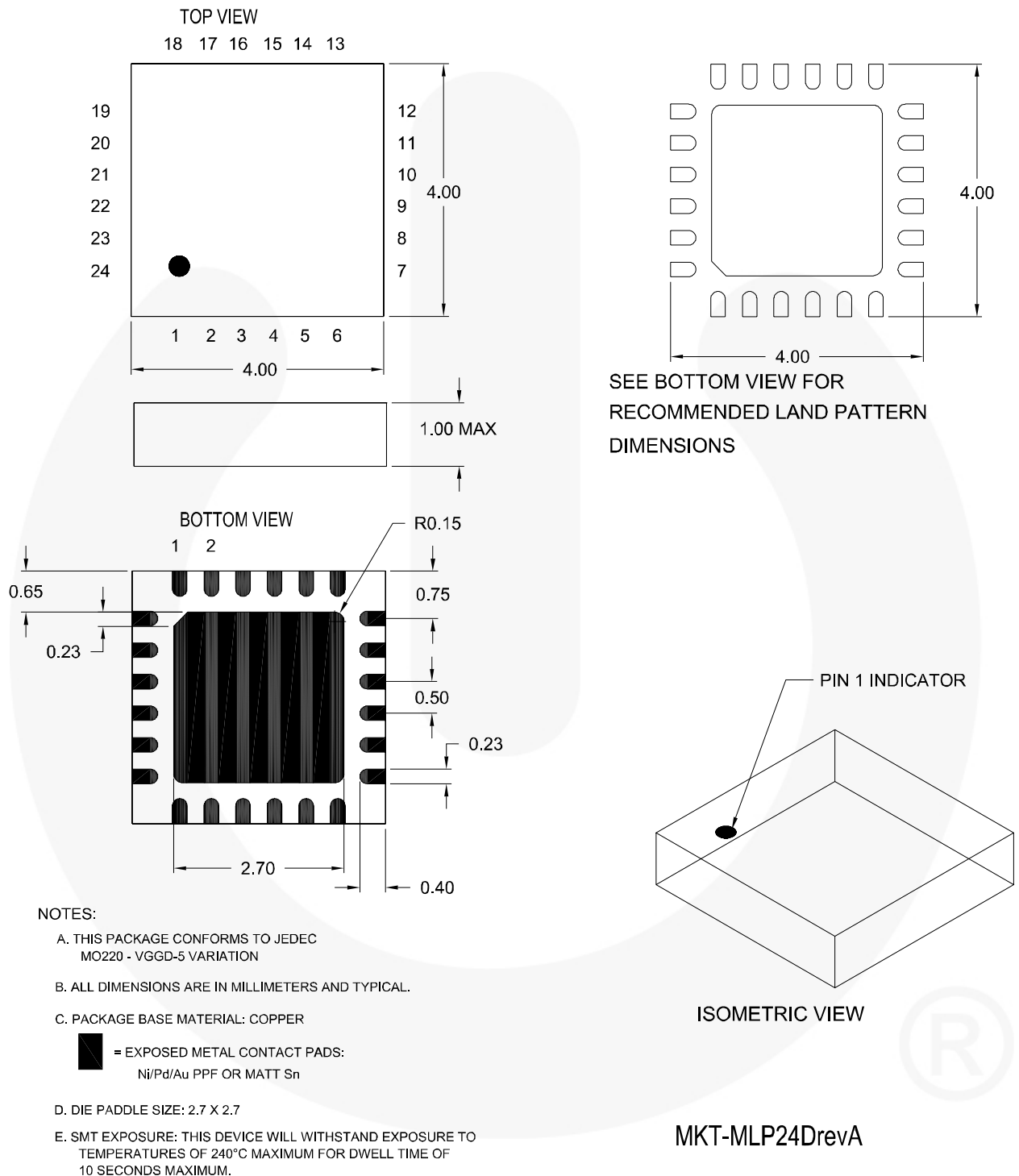



Figure 5. 24-Pin Molded Leadless Package (MLP)



TRADEMARKS

The following are registered and unregistered trademarks and service marks Fairchild Semiconductor owns or is authorized to use and is not intended to be an exhaustive list of all such trademarks.

ACEx [®]	Green FPS [™]	Power247 [®]	SuperSOT [™] -8
Build it Now [™]	Green FPST [™] e-Series [™]	POWEREDGE [®]	SyncFET [™]
CorePLUS [™]	GTO [™]	Power-SPM [™]	The Power Franchise [®]
CROSSVOLT [™]	i-Lo [™]	PowerTrench [®]	the power franchise
CTL [™]	IntelliMAX [™]	Programmable Active Droop [™]	TinyBoost [™]
Current Transfer Logic [™]	ISOPANAR [™]	QFET [®]	TinyBuck [™]
EcoSPARK [®]	MegaBuck [™]	QS [™]	TinyLogic [®]
f [®]	MICROCOUPLER [™]	QT Optoelectronics [™]	TINYOPTO [™]
Fairchild [®]	MicroFET [™]	Quiet Series [™]	TinyPower [™]
Fairchild Semiconductor [®]	MicroPak [™]	RapidConfigure [™]	TinyPWM [™]
FACT Quiet Series [™]	MillerDrive [™]	SMART START [™]	TinyWire [™]
FACT [®]	Motion-SPM [™]	SPM [®]	μSerDes [™]
FAST [®]	OPTOLOGIC [®]	STEALTH [™]	UHC [®]
FastvCore [™]	OPTOPLANAR [®]	SuperFET [™]	UniFET [™]
FPS [™]	 [®]	SuperSOT [™] -3	VCX [™]
FRFET [®]	PDP-SPM [™]	SuperSOT [™] -6	
Global Power Resource SM	Power220 [®]		

DISCLAIMER

FAIRCHILD SEMICONDUCTOR RESERVES THE RIGHT TO MAKE CHANGES WITHOUT FURTHER NOTICE TO ANY PRODUCTS HEREIN TO IMPROVE RELIABILITY, FUNCTION, OR DESIGN. FAIRCHILD DOES NOT ASSUME ANY LIABILITY ARISING OUT OF THE APPLICATION OR USE OF ANY PRODUCT OR CIRCUIT DESCRIBED HEREIN; NEITHER DOES IT CONVEY ANY LICENSE UNDER ITS PATENT RIGHTS, NOR THE RIGHTS OF OTHERS. THESE SPECIFICATIONS DO NOT EXPAND THE TERMS OF FAIRCHILD'S WORLDWIDE TERMS AND CONDITIONS, SPECIFICALLY THE WARRANTY THEREIN, WHICH COVERS THESE PRODUCTS.

LIFE SUPPORT POLICY

FAIRCHILD'S PRODUCTS ARE NOT AUTHORIZED FOR USE AS CRITICAL COMPONENTS IN LIFE SUPPORT DEVICES OR SYSTEMS WITHOUT THE EXPRESS WRITTEN APPROVAL OF FAIRCHILD SEMICONDUCTOR CORPORATION.

As used herein:

- Life support devices or systems are devices or systems which, (a) are intended for surgical implant into the body or (b) support or sustain life, and (c) whose failure to perform when properly used in accordance with instructions for use provided in the labeling, can be reasonably expected to result in a significant injury of the user.
- A critical component in any component of a life support, device, or system whose failure to perform can be reasonably expected to cause the failure of the life support device or system, or to affect its safety or effectiveness.

PRODUCT STATUS DEFINITIONS

Definition of Terms

Datasheet Identification	Product Status	Definition
Advance Information	Formative or In Design	This datasheet contains the design specifications for product development. Specifications may change in any manner without notice.
Preliminary	First Production	This datasheet contains preliminary data; supplementary data will be published at a later date. Fairchild Semiconductor reserves the right to make changes at any time without notice to improve design.
No Identification Needed	Full Production	This datasheet contains final specifications. Fairchild Semiconductor reserves the right to make changes at any time without notice to improve design.
Obsolete	Not In Production	This datasheet contains specifications on a product that has been discontinued by Fairchild Semiconductor. The datasheet is printed for reference information only.

Rev. I31