



Chipsmall Limited consists of a professional team with an average of over 10 year of expertise in the distribution of electronic components. Based in Hongkong, we have already established firm and mutual-benefit business relationships with customers from,Europe,America and south Asia,supplying obsolete and hard-to-find components to meet their specific needs.

With the principle of “Quality Parts,Customers Priority,Honest Operation,and Considerate Service”,our business mainly focus on the distribution of electronic components. Line cards we deal with include Microchip,ALPS,ROHM,Xilinx,Pulse,ON,Everlight and Freescale. Main products comprise IC,Modules,Potentiometer,IC Socket,Relay,Connector.Our parts cover such applications as commercial,industrial, and automotives areas.

We are looking forward to setting up business relationship with you and hope to provide you with the best service and solution. Let us make a better world for our industry!



Contact us

Tel: +86-755-8981 8866 Fax: +86-755-8427 6832

Email & Skype: info@chipsmall.com Web: www.chipsmall.com

Address: A1208, Overseas Decoration Building, #122 Zhenhua RD., Futian, Shenzhen, China



FB-EI-30026-000
SHT 1.1

NOTES:
1. LASER MARK, SEE WORK INSTRUCTION.

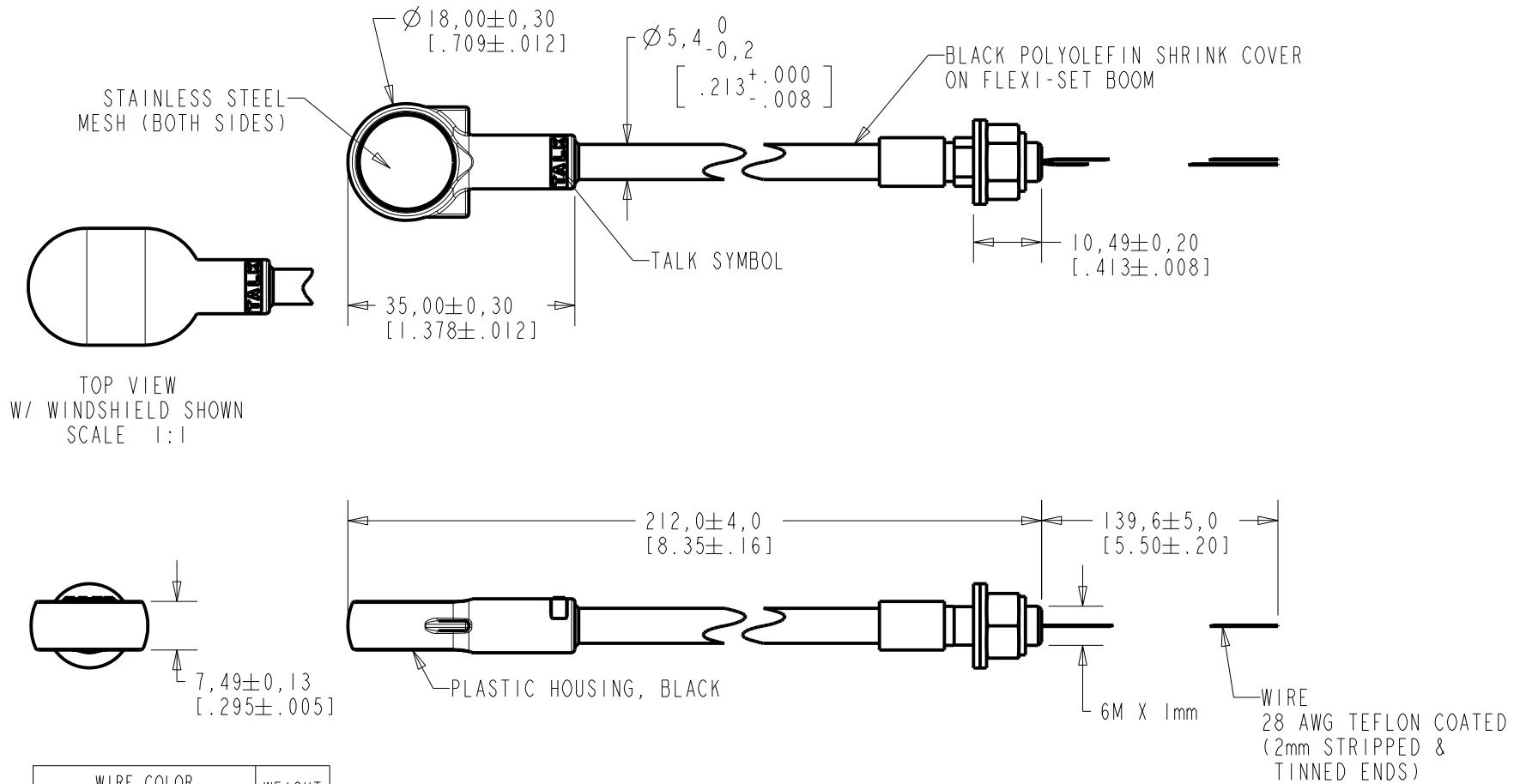

WIRE COLOR		WEIGHT GRAMS
+ve	OUTPUT	
RED	-	BLACK t.b.d.

DIMENSIONS IN MILLIMETERS [INCHES]

Revision	C.O. #	Implementation Date	RELEASE LEVEL	REVISION
H	C40101206	3-4-13	Active	H
G	C40100594	2-28-11		

KNOWLES ELECTRONICS
ITASCA, ILLINOIS U.S.A.

SCALE: 1:1	DR. BY: CRG	DATE: 4-28-08
DO NOT SCALE DRAWING	CK. BY: GJP	DATE: 8-4-06
TITLE: BOOM MICROPHONE	APP. BY: GJP	DATE: 8-4-06
OUTLINE DRAWING	FB-EI-30026-000 SHT 1.1	

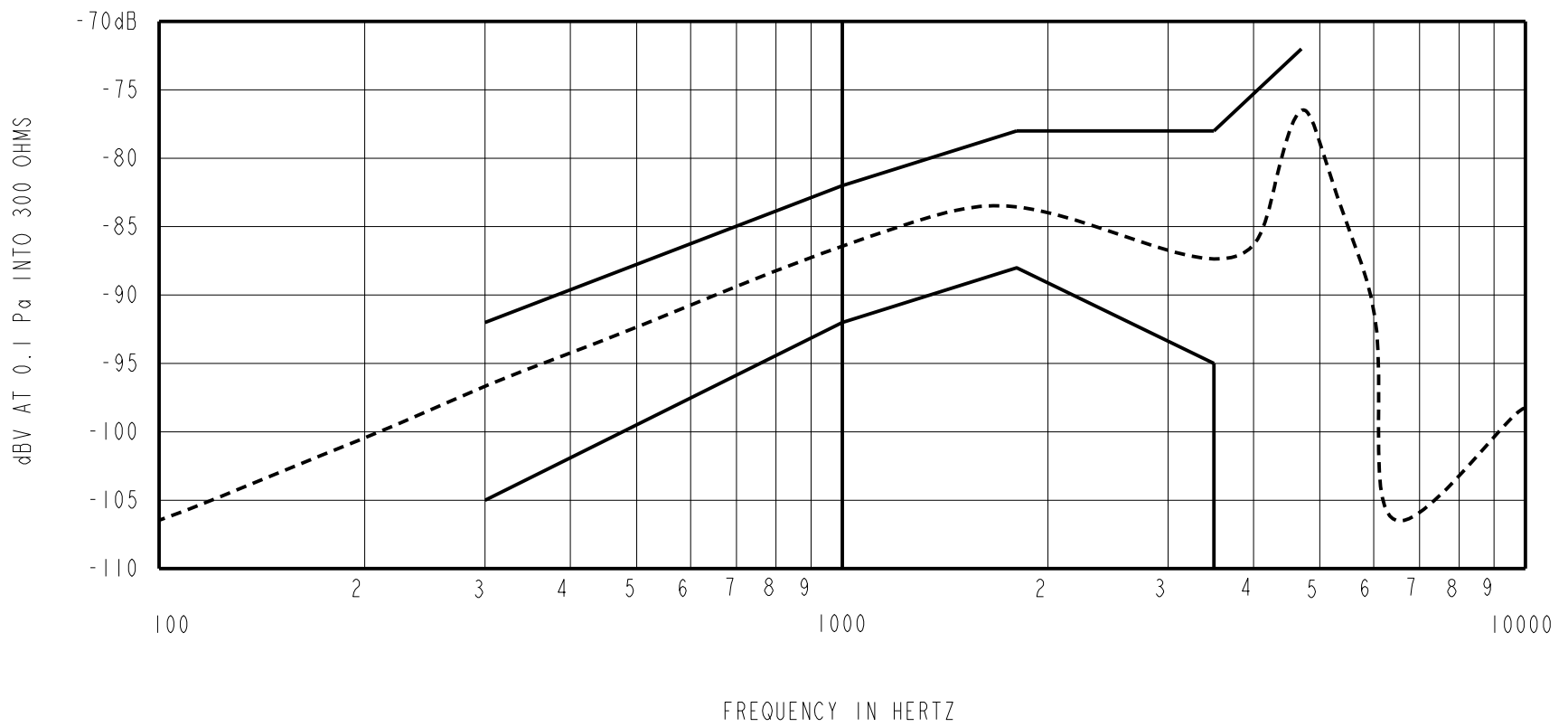

NOTES:

1. SENSITIVITY VALUES INDICATED ON THIS SPECIFICATION ARE VALID AT 50% HUMIDITY.
2.

FREQUENCY	SENSITIVITY		
	NIN.	NOM.	MAX.
300	-105	-97.5	-92
1000	-92	-87	-82
1800	-88	-83	-78
3500	-95	-87.5	-78
4000	---	-86.5	---
4700	---	-76.5	-72
3. TEST CONDITIONS:
 HEAD OF BOOM EXPOSED TO 94 dBSPL SWEPT SOUND FIELD AT 6mm FROM VOICE APERTURE.
 ARTIFICIAL VOICE:
 B & k 4227 MOUTH SIMULATOR.
4. FOR MICROPHONE CAPSULE SPEC. SEE DRAWING BJ-28471-000 SHEET 2.1.

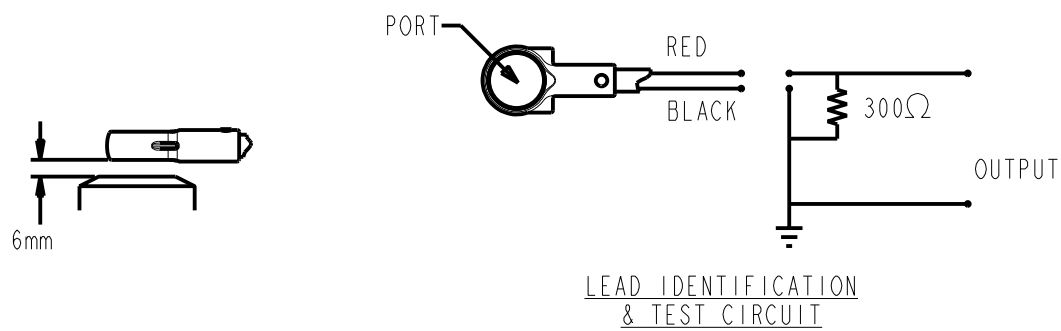

Revision	C.O. #	Implementation Date	RELEASE LEVEL	REVISION
H	C40101206	3-4-13	Active	H
G	C40100594	2-28-11		
WHEN TEST LIMITS ARE USED TO ESTABLISH INCOMING INSPECTION ACCEPTANCE/REJECTION CRITERIA, CORRELATION OF TEST EQUIPMENT WITH KNOWLES IS ALSO REQUIRED FOR ELIMINATION OF EQUIPMENT AND TEST METHOD VARIATION				
TITLE: BOOM MICROPHONE			FB-EI-30026-000	DR. BY DATE
PERFORMANCE SPECIFICATION			SHT 2.1	CRG 4-28-08
				CK. BY DATE
				GJP 8-4-06
				APP. BY DATE
				GJP 8-4-06

KNOWLES ELECTRONICS
 ITASCA, ILLINOIS U.S.A.