



Chipsmall Limited consists of a professional team with an average of over 10 year of expertise in the distribution of electronic components. Based in Hongkong, we have already established firm and mutual-benefit business relationships with customers from,Europe,America and south Asia,supplying obsolete and hard-to-find components to meet their specific needs.

With the principle of “Quality Parts,Customers Priority,Honest Operation,and Considerate Service”,our business mainly focus on the distribution of electronic components. Line cards we deal with include Microchip,ALPS,ROHM,Xilinx,Pulse,ON,Everlight and Freescale. Main products comprise IC,Modules,Potentiometer,IC Socket,Relay,Connector.Our parts cover such applications as commercial,industrial, and automotives areas.

We are looking forward to setting up business relationship with you and hope to provide you with the best service and solution. Let us make a better world for our industry!



## Contact us

Tel: +86-755-8981 8866 Fax: +86-755-8427 6832

Email & Skype: info@chipsmall.com Web: www.chipsmall.com

Address: A1208, Overseas Decoration Building, #122 Zhenhua RD., Futian, Shenzhen, China



THIS COPY IS PROVIDED ON A RESTRICTED BASIS AND IS NOT TO BE USED IN ANY WAY DETRIMENTAL TO THE INTERESTS OF PANDUIT CORP.

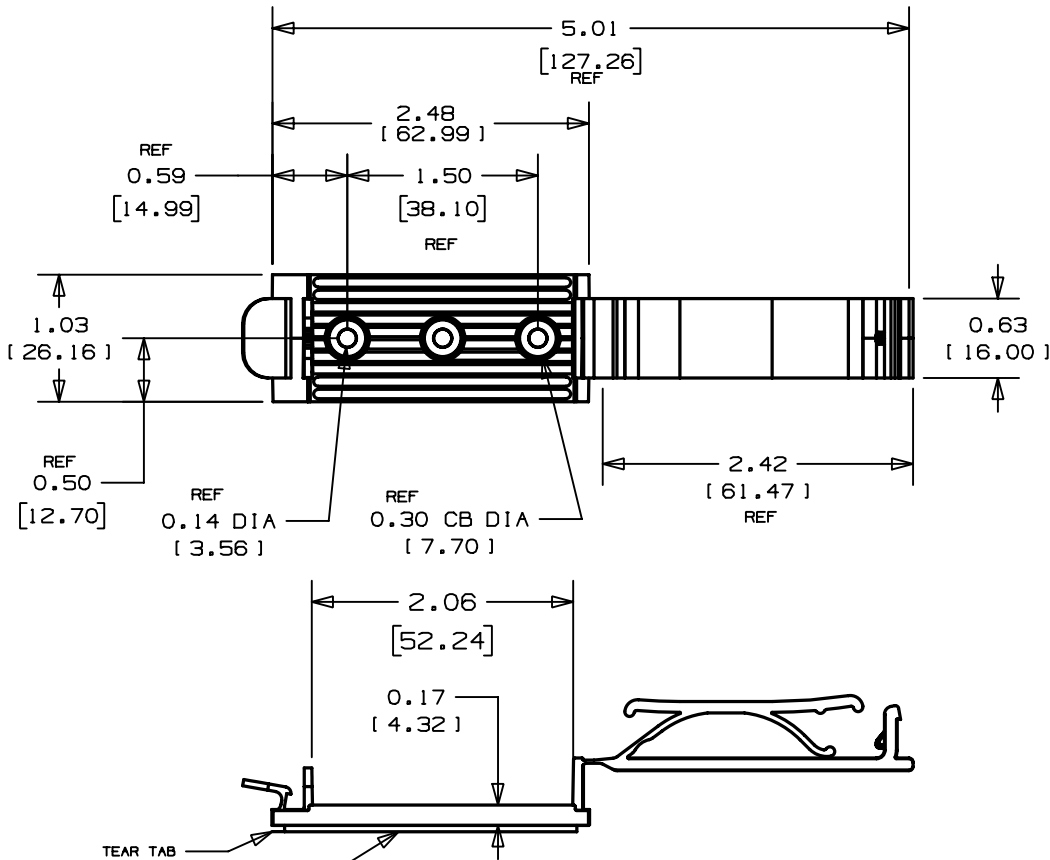

PANDUIT PART NUMBER	WEIGHT lbs/100 pcs (g)/100 pcs
FCH2-A	2.40 ( 1089.60 )

NO WARRANTY, EXPRESSED OR IMPLIED, IS MADE BY PANDUIT WITH RESPECT TO ADHESIVE BOND PERFORMANCE. AMONG OTHER THINGS, THE CONDITIONS UNDER WHICH THESE MOUNTS MAY BE APPLIED, AND/OR THE SURFACE TO WHICH THEY MAY BE APPLIED, ARE BEYOND PANDUIT'S CONTROL.

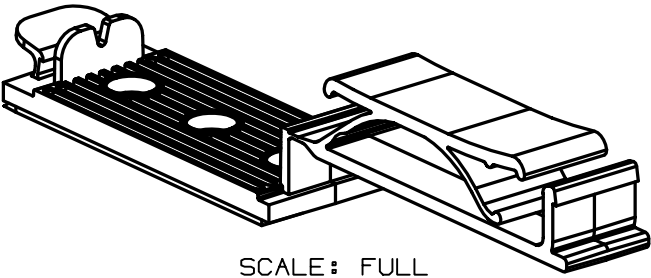

SCALE: FULL

**ADHESIVE BACKING**

PRESSURE SENSITIVE FOAM TAPE 0.040(1.02) THICK WITH RUBBER ADHESIVE AND PROTECTIVE LINER. MOUNT IS DESIGNED TO SUPPORT 1.28lbs. (581.7g) MAXIMUM WEIGHT ON A CLEAN, DRY, SMOOTH, GREASE-FREE SURFACE.

**TO APPLY FLAT CABLE HOLDER:**

1. REMOVE PROTECTIVE LINER
2. PLACE IN DESIRED LOCATION
3. APPLY PRESSURE TO THE TOP OF FLAT CABLE HOLDER.

DIMENSIONS IN BRACKETS ARE METRIC [ mm ]	
CAD FILENAME/LAYERS	G00239FH_PB_FCH2_06
<b>PANDUIT</b> CORP. TINLEY PARK, ILLINOIS	
FCH2-A FLAT CABLE HOLDER	
UNLESS OTHERWISE SPECIFIED, DIMENSIONAL TOLERANCES ARE: (.X) ±0.05 (1.3) (.XXX) ±0.010 (0.25) (.XX) ±0.02 (0.5) ANGLES ± 5°	UNLESS OTHERWISE SPECIFIED, ALL DIMENSIONS ARE GIVEN IN INCHES, THIRD ANGLE PROJECTION.
DRAWN BY JAD	MAT'L: NYLON 6/6
DATE 10-1-97	SCALE 3/4
DRW'D	DWG NO. GB0239FH
	SIZE A

REV	DATE	BY	CHK	DESCRIPTION	ECN - R	CUST	SUP
6	7/6/04	JAD		UPDATE PICTORIALY	GB0239FH	6	
5	5-10-02	LGG		ADDED ADHESIVE BACKING NOTE.	GB0239FH	5	