



Chipsmall Limited consists of a professional team with an average of over 10 year of expertise in the distribution of electronic components. Based in Hongkong, we have already established firm and mutual-benefit business relationships with customers from,Europe,America and south Asia,supplying obsolete and hard-to-find components to meet their specific needs.

With the principle of “Quality Parts,Customers Priority,Honest Operation,and Considerate Service”,our business mainly focus on the distribution of electronic components. Line cards we deal with include Microchip,ALPS,ROHM,Xilinx,Pulse,ON,Everlight and Freescale. Main products comprise IC,Modules,Potentiometer,IC Socket,Relay,Connector.Our parts cover such applications as commercial,industrial, and automotives areas.

We are looking forward to setting up business relationship with you and hope to provide you with the best service and solution. Let us make a better world for our industry!



Contact us

Tel: +86-755-8981 8866 Fax: +86-755-8427 6832

Email & Skype: info@chipsmall.com Web: www.chipsmall.com

Address: A1208, Overseas Decoration Building, #122 Zhenhua RD., Futian, Shenzhen, China



FCM8202

3-Phase Sinusoidal Brushless DC Motor Controller

Features

- Supports Space Vector Modulation (SVM)
- Supports Sine-Wave & Square-Wave Solutions
- Built-in Clock Generator
- Built-in Error Amplifier for Torque Loop Control
- Direct Duty Control
- Square-Wave 120°, Sine-Wave 180° Turn-on
- PLL Angle Detection (Hall Sensors)
- Current Leading Phase Correction
- Two Selectable Dead Times
- Synchronous Rectifying
- Over-Voltage and Under-Voltage Protections
- Motor and Power Transistors for Over-Voltage Protections (OVP)
- Three Levels of Over-Current Protections (OCP)
- Adjustable OC Timer
- Over-Temperature Protection (OTP)

Applications

- BLDC Motor or PMSM Control
- Low Noise Motor Applications
- Fan, Pump, Tools, etc.

Description

FCM8202 is a three-phase sinusoidal Brushless DC (BLDC) motor or Permanent Magnet Synchronous Motor (PMSM) controller. It comes with the advanced Hall sensor design. Using the Hall sensor signals, the control system is able to execute the PWM commutation by switching the three-phase inverter. There are two PWM modes: Sine-Wave Mode and Square-Wave Mode. The Square-Wave Mode includes PWM-PWM and PWM-ON approaches to improve the efficiency of the motor drive.

Complete protection functions including over-voltage, over-current, over-temperature, and short-circuit protections prevent the control circuits and the motor from being damaged, particularly under stressed applications and demanding environments.

Ordering Information

Part Number	Operating Temperature Range	Package	Packing Method
FCM8202QY	-40°C to 125°C	32-Lead, LQFP, JEDEC MS-026, Variation BBA, 7 mm Square	Tray

Marking Information

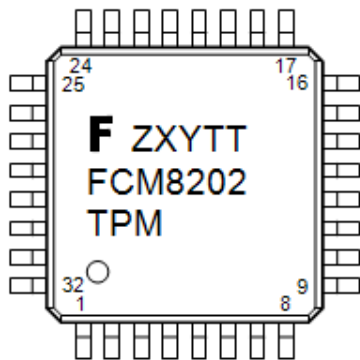

F- Fairchild Logo
 Z- Plant Code
 X- 1-Digit Year Code
 Y- 1-Digit Week Code
 TT: 2-Digit Die Run Code
 T: Package Type (Q=LQFP)
 P: Y=Green Package
 M: Die Run Code

Figure 3. Top Mark

Pin Configuration

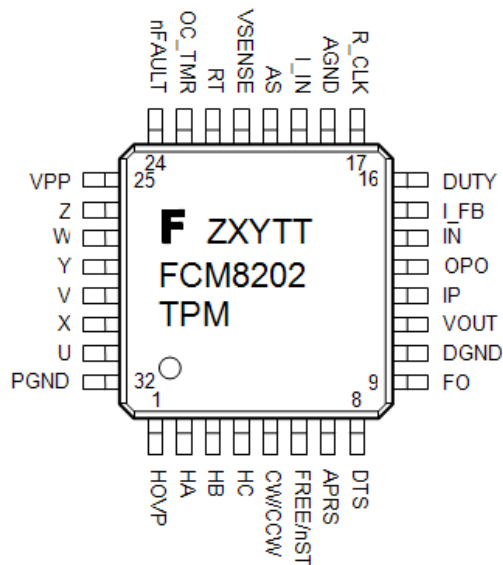

Figure 4. Pin Configuration

Pin Definitions

Pin #	Name	Description
1	HOVP	Motor Drive Over-Voltage Protection Output. Can be connected to an external power transistor for discharging the Back-EMF.
2	HA	Hall A Sensor Input. Phase-U magnetic field detection.
3	HB	Hall B Sensor Input. Phase-V magnetic field detection.
4	HC	Hall C Sensor Input. Phase-W magnetic field detection.
5	CW/CCW	Direction Control Input. This pin has a 200 k Ω internal pull-up. HIGH: CW, LOW: CCW.
6	FREE/nST	Free and Start Control Input. This pin has a 200 k Ω internal pull-up. HIGH: Free, LOW: Start.
7	APRS	Angle Predict Range Selection Input. This pin has a 200 k Ω internal pull-up. LOW: 0.8 ~ 80 Hz, HIGH: 3.2 ~ 320 Hz Hall Frequency.
8	DTS	Dead-Time Selection Input. This pin has a 200 k Ω internal pull-up. LOW: 3 μ s, HIGH: 4 μ s.
9	FO	Revolution Pulse Output. Pulses per revolution = motor poles \div 2 \times 3.
10	DGND	Digital Ground
11	VOUT	Voltage Regulator Output. A 0.1 μ F (minimum) capacitor should be connected between this pin and ground.
12	IP	Positive Input of Torque Error Amplifier
13	OPO	Output of Torque Error Amplifier
14	IN	Negative Input of Torque Error Amplifier
15	I_FB	Current Feedback Output
16	DUTY	PWM Duty Control Input. Designed to directly control the PWM duty cycle.
17	R_CLK	External Resistor of Clock Generator. Designed for determining the frequency of internal clock generator.
18	AGND	Analog Ground
19	I_IN	Current Feedback Input
20	AS	Angle Shift Input. Designed for correcting the lead angle of PWM output signals. The range is from 0° to 60° related to the induced magnetic voltage.
21	VSENSE	Motor Drive Voltage-Sensing Resistor. Designed for determining the voltage level of over-voltage protections.
22	RT	Thermistor Voltage Input. Connect to a Negative Temperature Coefficient (NTC) thermistor for the over-temperature protection.
23	OC_TMR	Overload Time-Out Programmable Input. Connect to a capacitor for determining the time delay of overload protection.
24	nFAULT	Fault Flag. Open-drain output, LOW: system failure.
25	VPP	Supply Voltage Input
26	Z	PWM Output of W-Phase, Low-Side
27	W	PWM Output of W-Phase, High-Side
28	Y	PWM Output of V-Phase, Low-Side
29	V	PWM Output of V-Phase, High-Side
30	X	PWM Output of U-Phase, Low-Side
31	U	PWM Output of U-Phase, High-Side
32	PGND	High-Voltage Ground

Absolute Maximum Ratings

Stresses exceeding the absolute maximum ratings may damage the device. The device may not function or be operable above the recommended operating conditions and stressing the parts to these levels is not recommended. In addition, extended exposure to stresses above the recommended operating conditions may affect device reliability. The absolute maximum ratings are stress ratings only.

Symbol	Parameter		Min.	Max.	Unit
V _{PP}	Supply Voltage		0	30	V
θ _{JA}	Thermal Resistance, Junction-to-ambient			82	°C/W
θ _{JC}	Thermal Resistance, Junction-to-case			29	°C/W
T _J	Junction Temperature			+150	°C
ESD	Electrostatic Discharge Protection Level	Human Body Model, JESD22-A114		2.50	kV
		Charged Device Model, JESD22-C101		1.25	

Recommended Operating Conditions

The Recommended Operating Conditions table defines the conditions for actual device operation. Recommended operating conditions are specified to ensure optimal performance to the datasheet specifications. Fairchild does not recommend exceeding them or designing to Absolute Maximum Ratings.

Symbol	Parameter	Min.	Typ.	Max.	Unit
T _A	Operating Ambient Temperature	-40		+125	°C
V _{PP}	Supply Voltage	10	12	17	V
f _{SYS}	System Clock	0.96	1.28	1.92	MHz
R_CLK	Clock Generator External Resistor		12		kΩ
R _{I_IN}	I_IN Bias Resistor		10		kΩ

Electrical Characteristics

$V_{PP} = 12\text{ V}$ and $T_A = 25^\circ\text{C}$ unless otherwise noted.

Symbol	Parameter	Conditions	Min.	Typ.	Max.	Units
V_{PP} Section						
V_{PP_ON}	Turn-On Threshold Voltage		8.5	9.0	9.5	V
V_{PP_OFF}	Turn-Off Threshold Voltage		7.5	8.0	8.5	V
I_{DD_OP}	Operating Supply Current	$V_{PP} = 12\text{ V}$, $f_{SYS} = 1.28\text{ MHz}$	4.0	5.0	6.5	mA
Voltage Regulator Section						
V_{VOUT}	Regulator Output Voltage	Output Current 5 mA	5.0	5.2	5.5	V
I_{VOUT}	Regulator Output Current	$V_{VOUT} = 5.2\text{ V}$			10	mA
C_{VOUT}	Regulator External Capacitor		0.1			μF
Digital I/O Section						
V_{IH_HALL}	Hall Signals Input High-Level		4.0			V
V_{IL_HALL}	Hall Signals Input Low-Level				1.0	V
V_{HYS_HALL}	Hall Signals Hysteresis Voltage		2.0	2.5	3.0	V
t_{DEB_HALL}	Hall Signals De-bounce Time			5		μs
R_{DIO_UP}	Digital I/O Internal Pull High Resistor		150	200	250	k Ω
High-Voltage I/O Section						
V_{OH_PWM}	PWM Signals Output High-Level (U/V/W/X/Y/Z)	$V_{PP} = 12\text{ V}$, $I_O = 4\text{ mA}$	10			V
V_{OL_PWM}	PWM Signals Output Low-Level (U/V/W/X/Y/Z)	$V_{PP} = 12\text{ V}$, $I_O = 4\text{ mA}$			1	V
V_{OH_HOVP}	HOVP Output High-Level	$V_{PP} = 12\text{ V}$, $I_O = 1\text{ mA}$	9.0	9.7	10.0	V
V_{OL_HOVP}	HOVP Output Low-Level	$V_{PP} = 12\text{ V}$, $I_O = 1\text{ mA}$			1	V
PWM Control Section						
V_{FD}	Full Duty Voltage of DUTY Pin		4.0	4.3	4.6	V
V_{ZD}	Zero Duty Voltage of DUTY Pin			0.7		V
t_{PWM_MIN}	PWM Minimum On Time	$R_CLK = 12\text{ k}\Omega$		1		μs
t_{DEAD0}	PWM Dead Time 3 μs	DTS = LOW	2.15	2.88	3.45	μs
t_{DEAD1}	PWM Dead Time 4 μs	DTS = HIGH	3.35	3.91	4.65	μs
f_{PWM_20K}	PWM Frequency 20 kHz	$R_CLK = 12\text{ k}\Omega$	18.5	20.0	21.5	kHz
I_{SOURCE_OPO}	Current Source Capability of OPO Pin	$I_P = 5\text{ V}$, $I_N = 0\text{ V}$, $OPO = 0\text{ V}$	4.0	5.0	6.0	mA
I_{SINK_OPO}	Current Sink Capability of OPO Pin	$I_P = 0\text{ V}$, $I_N = 5\text{ V}$, $OPO = 5\text{ V}$	-4.0	-5.0	-6.0	mA
A_{VERR}	Gain of Torque Error Amplifier			60		dB
GBW_{ERR}	Unit-Gain Bandwidth of Torque Error Amplifier			10		MHz
Sine Wave PWM Generator						
V_{SIN_ENA}	Sine Wave Enable Threshold of DUTY Pin			0.75		V
V_{SIN_DIS}	Sine Wave Disable Threshold of DUTY Pin			0.65		V
t_{SIN_ENA}	Sine Wave Enable Debounce Time			1		ms
t_{SIN_DIS}	Sine Wave Disable Debounce Time			100		ms

Continued on the following page...

Electrical Characteristics (Continued)V_{PP} = 12 V and T_A = 25°C unless otherwise noted.

Symbol	Parameter	Condition	Min.	Typ.	Max.	Unit
Over-Current Protection Section						
V _{OCP_SH}	Short-Circuit Current Protection Threshold Voltage			2.5		V
V _{OCP_CYC}	Cycle-by-Cycle Current Protection Threshold Voltage			1.5		V
V _{OCP_OL}	Overload Current Protection Threshold Voltage			1.4		V
V _{OC_TMR}	OC_TMR Threshold Voltage			2.5		V
I _{TMR_CHG}	OC_TMR Charge Current	OC_TMR = 0 V	30	40	50	μA
I _{TMR_DIS}	OC_TMR Discharge Current	OC_TMR = 5 V	5	10	15	μA
I _{BIAS_I_IN}	Bias Current of I_IN	R _{I_IN} = 10 kΩ	40	50	60	μA
I _{O_I_FB}	I_FB Output Current			0.5		mA
G _{I_FB}	I_FB Output Gain			8		
Over- / Under-Voltage Protection (OVP/UVP) Section						
V _{OV_VPP}	System OVP Threshold Voltage			18		V
V _{OV_VPP_RLS}	System OVP Release Voltage			17		V
t _{OV_VPP}	System OVP Debounce Time			100		μs
V _{UV_VPP}	System UVP Threshold Voltage		7.5	8.0	8.5	V
V _{UV_VPP_RLS}	System UVP Release Voltage		8.5	9.0	9.5	V
V _{UV_VOUT}	V _{OUT} UVP Threshold Voltage			4		V
V _{UV_VOUT_RLS}	V _{OUT} UVP Release Voltage			4.5		V
V _{OV_MOTOR}	Motor Drive Voltage OVP Threshold Voltage		4.3	4.5	4.8	V
V _{RL_MOTOR}	Motor Drive Voltage OVP Release Voltage			4.0		V
Over-Temperature Protection (OTP) Section						
V _{RT}	OTP Threshold Voltage		0.9	1.0	1.1	V
V _{RT_RLS}	OTP Release Voltage		1.15	1.20	1.25	V
I _{RT}	RT Pin Source Current		40	50	60	μA
Pin Open / Short Protection Section						
V _{SHORT}	Pin Short Protection Level	R_CLK Pin		0.2		V
V _{OPEN}	Pin Open Protection Level	R_CLK and RT Pins	4.6	4.8	5.2	V

Typical Performance Characteristics

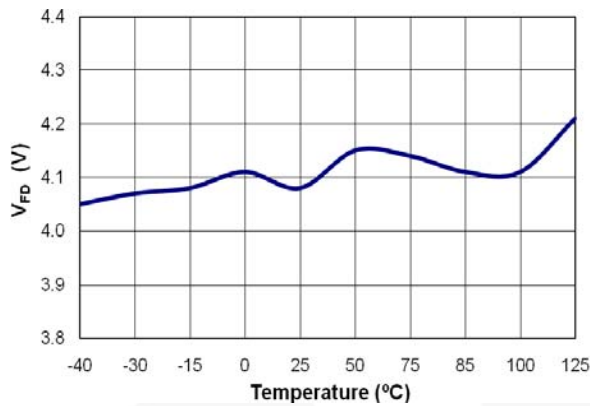

Figure 5. PWM-Full Duty Voltage (V_{FD}) vs. Temperature

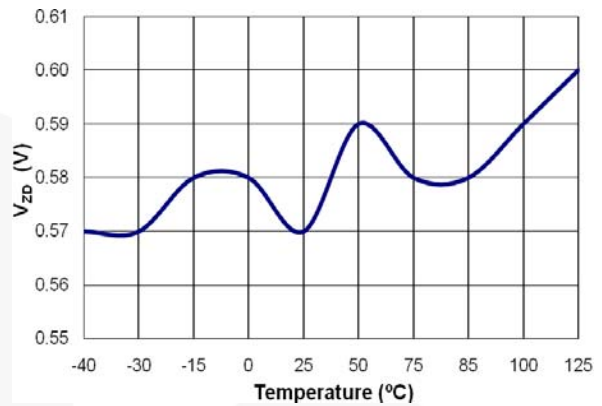

Figure 6. PWM Zero-Duty Voltage (V_{ZD}) vs. Temperature

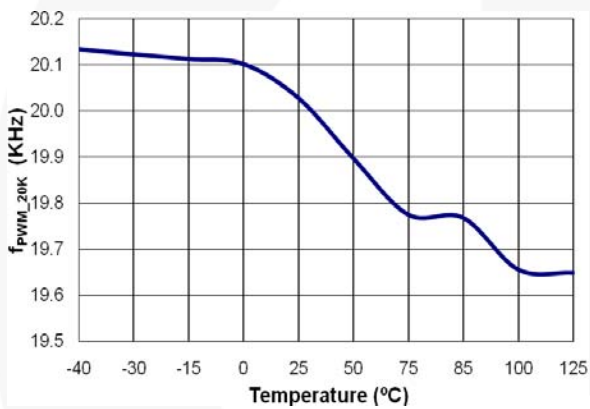

Figure 7. PWM Frequency 20 kHz (f_{PWM_20K}) vs. Temperature

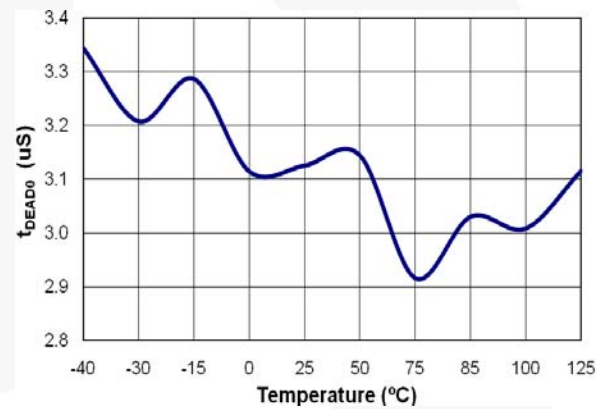

Figure 8. PWM Dead Time 3 μ s (t_{DEAD0}) vs. Temperature

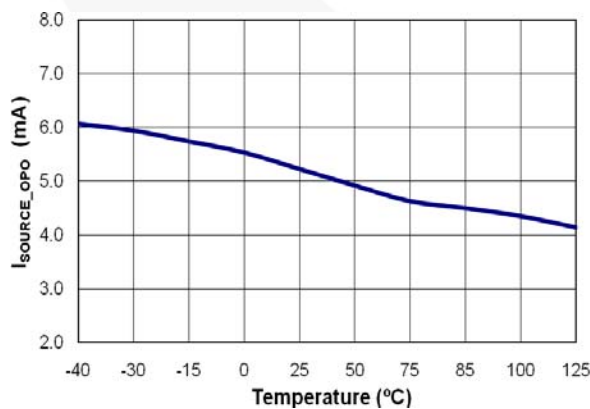

Figure 9. OPO Current Source (I_{SOURCE_OPO}) vs. Temperature

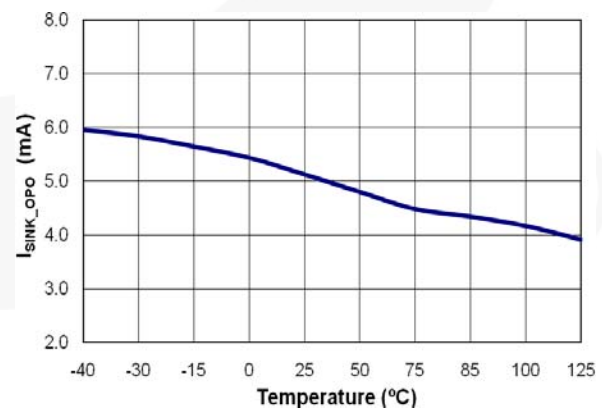

Figure 10. OPO Current Sink (I_{SINK_OPO}) vs. Temperature

Typical Performance Characteristics (Continued)

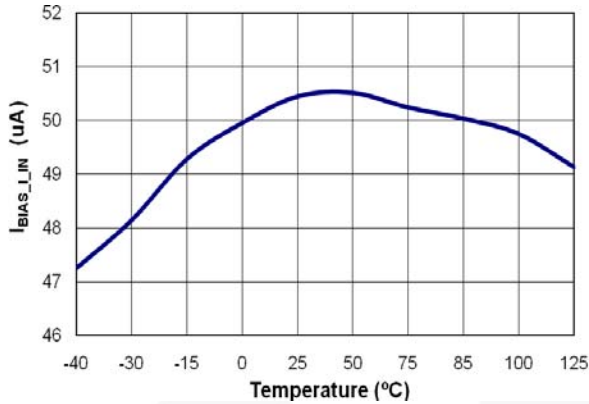

Figure 11. I_{IN} Bias Current ($I_{BIAS_I_IN}$) vs. Temperature

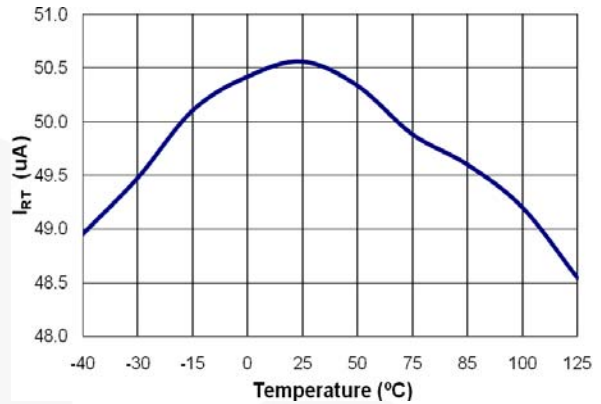

Figure 12. RT Current Source (I_{RT}) vs. Temperature

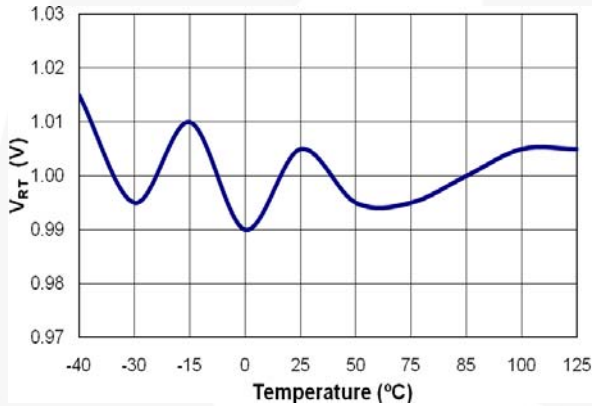

Figure 13. OTP Threshold Voltage (V_{RT}) vs. Temperature

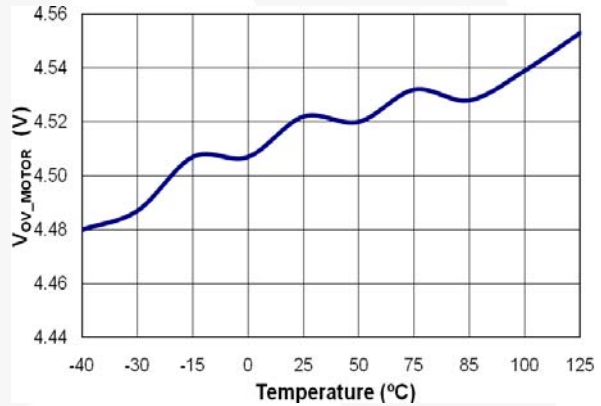

Figure 14. Motor OVP Threshold Voltage (V_{OV_MOTOR}) vs. Temperature

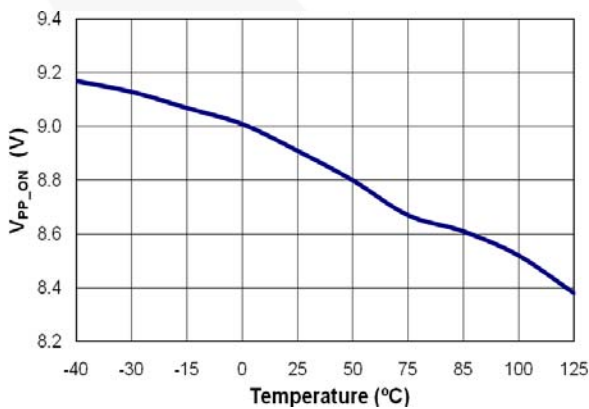

Figure 15. V_{PP} Turn-On Threshold Voltage (V_{PP_ON}) vs. Temperature

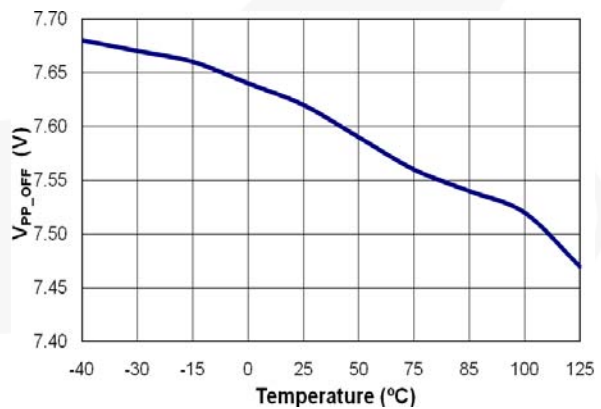

Figure 16. V_{PP} Turn-Off Threshold Voltage (V_{PP_OFF}) vs. Temperature

Functional Description

Power Management and Regulator

FCM8202 can operate in a wide input voltage (V_{PP}) range from 10 V to 17.5 V. The VOUT pin is the output terminal of an internal voltage regulator. The typical output voltage range is between 5.0 V to 5.2 V. To stabilize the VOUT circuit, an external capacitor must be connected closely between this terminal and the ground. If the V_{PP} voltage is lower than the 8 V threshold, the FCM8202 is shut down and the internal registers are reset.

Clock Generator

FCM8202 comes with a programmable oscillator. Being determined by an externally added resistor, the system clock, R_CLK, can be programmed from 960 kHz to 1920 kHz. The switching frequency of the PWM signal is equal to 1/64 (divided by 64) of the system clock. Therefore, when the system clock is configured as 960 kHz, PWM is $960 \text{ kHz} / 64 = 15 \text{ kHz}$. Similarly, if a 20 kHz PWM is intended, the system clock should be set as 1.28 MHz.

PWM Commutation

FCM8202 supports both square-wave PWM and sine-wave PWM for the BLDC motor control. The controller comes with the Hall-sensor design used to align the rotor position of the motor. For Square-Wave Mode, the PWM output commutation is shown at Table 1.

Table 1. Square Wave Commutation

CW	Hall	Hall	U-V-W	X-Y-Z
X	000	0	0-0-0	0-0-0
X	111	7	0-0-0	0-0-0
1	001	1	P-0-0	Pb-1-0
1	011	3	0-0-P	0-1-Pb
1	010	2	0-0-P	1-0-Pb
1	110	6	0-P-0	1-Pb-0
1	100	4	0-P-0	0-Pb-1
1	101	5	P-0-0	Pb-0-1
0	101	5	0-0-P	1-0-Pb
0	100	4	0-0-P	0-1-Pb
0	110	6	P-0-0	Pb-1-0
0	010	2	P-0-0	Pb-0-1
0	011	3	0-P-0	0-Pb-1
0	001	1	0-P-0	1-Pb-0

Note:

1. P = PWM, Pb = PWM inverse.
2. X = don't care.

HALL Signals Input

FCM8202 provides a 3 ~ 6 μs debounce time for each Hall signal input to reduce the glitch of the Hall signals. When the transition of the Hall signal is slow, a glitch might be produced and an error follow. Through a built-in Hall signal debounce circuit, FCM8202 minimizes the risk of the glitches and related errors.

PWM Duty Cycle and Operation

The PWM duty is proportional to the voltage levels on the OPO pin and DUTY pin. A FREE/nST pin is utilized to enable the PWM signals. When FREE/nST pin is set as logic HIGH, the PWM state is in Free Mode and all PWM outputs (U, V, W, X, Y, Z pins) are logic LOW. Once the FREE/nST pin goes logic LOW, the FCM8202 starts operating the PWM.

Sine-Wave Generator

FCM8202 includes space vector modulation (SVM) for the sine-wave PWM. An angle-detect circuit phase-locks the rotor position using the Hall signals of the motor. The resolution is 32 steps per 60°. Through the PWM operation, the motor current of each phase is sine-wave. The angle shift between each phase is 120°.

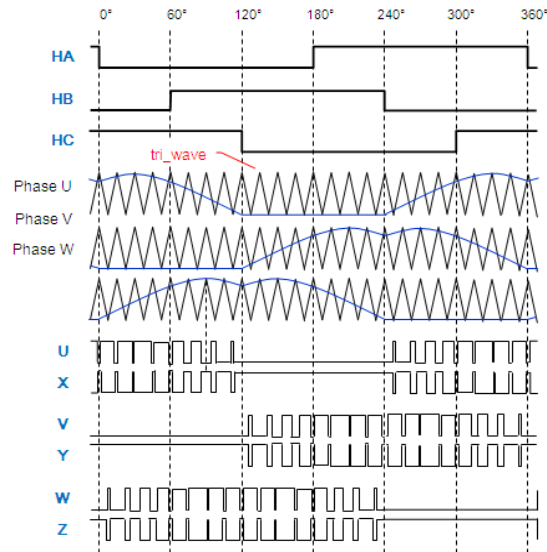

Figure 17. Sine-Wave Output at CW = 1

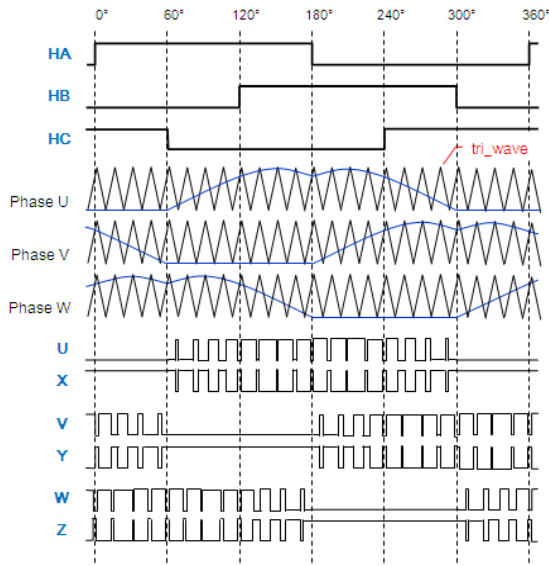

Figure 18. Sine-Wave Output at CW = 0

Current Feedback and Protections

The current feedback circuit performs two major functions: (1) for generating a current feedback signal for the motor control (2) for the over-current protection. The I_IN pin outputs 50 μA current to provide a DC bias on the I_IN terminal to prevent a negative voltage. Equation 1 shows the I_FB and the I_IN. A 0.5 V DC bias on I_IN is recommended. The maximum average current signal is 1 V. By using these parameters, the maximum I_FB signal swing is 0.5 V ~ 4.5 V.

$$V_{I_FB} = (V_S \times 8) + (I_{BIAS_I_IN} \times R_{BIAS}) \quad (1)$$

Protections and Faults

Table 2. Faults Table

Type	State	Trigger	Release
V _{PP} OV	Free	V _{PP} > 18 V	V _{PP} < 17 V
V _{PP} UV	Free, Reset	V _{PP} < 8 V	V _{PP} > 9 V
V _{OUT} UV	Free	V _{OUT} < 4 V	V _{OUT} > 4.5 V
RT	Free	R _T < 1.0 V	R _T > 1.2 V
OS	Free	Open and Short	FREE/nST ↗
Hall Error	Free	Hall = 000 or 111	
HOVP	Free	V _{SENSE} > 4.5 V	V _{SENSE} < 4.0 V
OC_Latch	Free	I_IN > 1.4 V	FREE/nST ↗
SHORT	Free	I_IN > 2.5 V	FREE/nST ↗

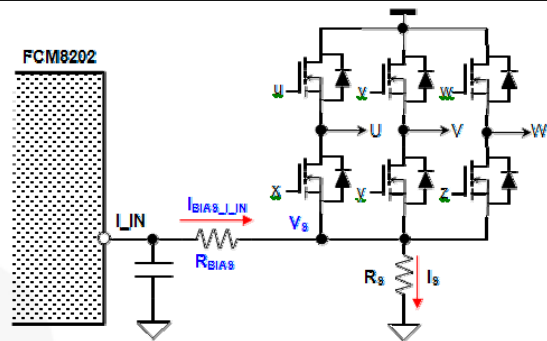

Figure 19. Current Feedback Flow

FCM8202 provides three levels of over-current protection (OCP). The first level is 1.4 V, is used for overload current protection with the OCP timer delay. If the I_IN is higher than 1.4 V, the OC timer is triggered. The OC_Latch is enabled once the timer exceeds its time-out limit. The second level is 1.5 V, used for the cycle-by-cycle current limit. The PWM signal is turned off immediately when the I_IN is > 1.5 V. The third level is 2.5 V, designed for short-circuit protection. If the I_IN is > 2.5 V for over three PWM pulses, all PWM outputs (U, V, W, X, Y, Z pins) are turned off.

Physical Dimensions

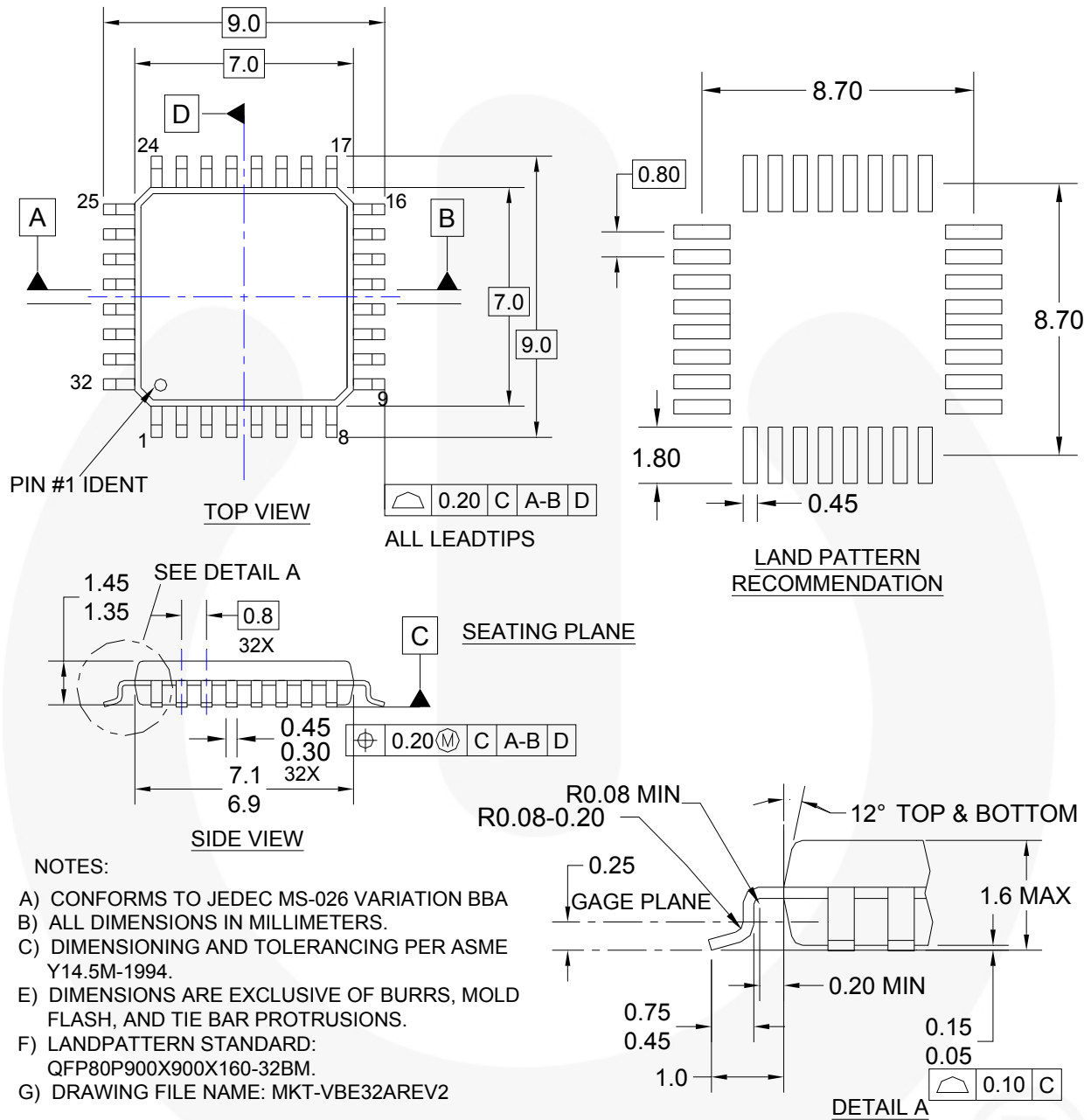

Figure 20. 32-Low-Profile, Quad Flat Pack Package (LQFP)

Package drawings are provided as a service to customers considering Fairchild components. Drawings may change in any manner without notice. Please note the revision and/or date on the drawing and contact a Fairchild Semiconductor representative to verify or obtain the most recent revision. Package specifications do not expand the terms of Fairchild's worldwide terms and conditions, specifically the warranty therein, which covers Fairchild products.

Always visit Fairchild Semiconductor's online packaging area for the most recent package drawings:
<http://www.fairchildsemi.com/packaging/>



TRADEMARKS

The following includes registered and unregistered trademarks and service marks, owned by Fairchild Semiconductor and/or its global subsidiaries, and is not intended to be an exhaustive list of all such trademarks.

- | | | | |
|--|--|--|---|
| 2Cool™ | FPS™ |  PowerTrench® | Sync-Lock™ |
| AccuPower™ | F-PFST™ | PowerXS™ |  SYSTEM GENERAL® |
| AX-CAP®* | FRFET® | Programmable Active Droop™ | TinyBoost™ |
| BitSiC™ | Global Power Resource™ | QFET® | TinyBuck™ |
| Build it Now™ | GreenBridge™ | QST™ | TinyCalc™ |
| CorePLUS™ | Green FPS™ | Quiet Series™ | TinyLogic® |
| CorePOWER™ | Green FPS™ e-Series™ | RapidConfigure™ | TINYOPTO™ |
| CROSSVOLT™ | Gmax™ |  Saving our world, 1mW/W at a time™ | TinyPower™ |
| CTL™ | GTO™ | SignalWise™ | TinyPWM™ |
| Current Transfer Logic™ | IntelliMAX™ | SmartMax™ | TinyWire™ |
| DEUXPEED® | ISOPLANAR™ | SMART START™ | TranSiC™ |
| Dual Cool™ | Making Small Speakers Sound Louder and Better™ | Solutions for Your Success™ | TriFault Detect™ |
| EcoSPARK® | MegaBuck™ | SPM® | TRUECURRENT®* |
| EfficientMax™ | MICROCOUPLER™ | STEALTH™ | µSerDes™ |
| ESBC™ | MicroFET™ | SuperFET® |  µSerDes™ |
|  Fairchild® | MicroPak™ | SuperSOT™-3 | UHC® |
| Fairchild Semiconductor® | MicroPak2™ | SuperSOT™-6 | Ultra FRFET™ |
| FACT Quiet Series™ | MillerDrive™ | SuperSOT™-8 | UniFET™ |
| FACT® | MotionMax™ | SupreMOS® | VCX™ |
| FAST® | mWSaver™ | SynCFET™ | VisualMax™ |
| FastvCore™ | OptoHIT™ | | VoltagePlus™ |
| FETBench™ | OPTOLOGIC® | | XST™ |
| | OPTOPLANAR® | | |

* Trademarks of System General Corporation, used under license by Fairchild Semiconductor.

DISCLAIMER

FAIRCHILD SEMICONDUCTOR RESERVES THE RIGHT TO MAKE CHANGES WITHOUT FURTHER NOTICE TO ANY PRODUCTS HEREIN TO IMPROVE RELIABILITY, FUNCTION, OR DESIGN. FAIRCHILD DOES NOT ASSUME ANY LIABILITY ARISING OUT OF THE APPLICATION OR USE OF ANY PRODUCT OR CIRCUIT DESCRIBED HEREIN, NEITHER DOES IT CONVEY ANY LICENSE UNDER ITS PATENT RIGHTS, NOR THE RIGHTS OF OTHERS. THESE SPECIFICATIONS DO NOT EXPAND THE TERMS OF FAIRCHILD'S WORLDWIDE TERMS AND CONDITIONS, SPECIFICALLY THE WARRANTY THEREIN, WHICH COVERS THESE PRODUCTS.

LIFE SUPPORT POLICY

FAIRCHILD'S PRODUCTS ARE NOT AUTHORIZED FOR USE AS CRITICAL COMPONENTS IN LIFE SUPPORT DEVICES OR SYSTEMS WITHOUT THE EXPRESS WRITTEN APPROVAL OF FAIRCHILD SEMICONDUCTOR CORPORATION.

As used herein:

1. Life support devices or systems are devices or systems which, (a) are intended for surgical implant into the body or (b) support or sustain life, and (c) whose failure to perform when properly used in accordance with instructions for use provided in the labeling, can be reasonably expected to result in a significant injury of the user.
2. A critical component in any component of a life support, device, or system whose failure to perform can be reasonably expected to cause the failure of the life support device or system, or to affect its safety or effectiveness.

ANTI-COUNTERFEITING POLICY

Fairchild Semiconductor Corporation's Anti-Counterfeiting Policy. Fairchild's Anti-Counterfeiting Policy is also stated on our external website, www.fairchildsemi.com, under Sales Support.

Counterfeiting of semiconductor parts is a growing problem in the industry. All manufacturers of semiconductor products are experiencing counterfeiting of their parts. Customers who inadvertently purchase counterfeit parts experience many problems such as loss of brand reputation, substandard performance, failed applications, and increased cost of production and manufacturing delays. Fairchild is taking strong measures to protect ourselves and our customers from the proliferation of counterfeit parts. Fairchild strongly encourages customers to purchase Fairchild parts either directly from Fairchild or from Authorized Fairchild Distributors who are listed by country on our web page cited above. Products customers buy either from Fairchild directly or from Authorized Fairchild Distributors are genuine parts, have full traceability, meet Fairchild's quality standards for handling and storage and provide access to Fairchild's full range of up-to-date technical and product information. Fairchild and our Authorized Distributors will stand behind all warranties and will appropriately address any warranty issues that may arise. Fairchild will not provide any warranty coverage or other assistance for parts bought from Unauthorized Sources. Fairchild is committed to combat this global problem and encourage our customers to do their part in stopping this practice by buying direct or from authorized distributors.

PRODUCT STATUS DEFINITIONS

Definition of Terms

Datasheet Identification	Product Status	Definition
Advance Information	Formative / In Design	Datasheet contains the design specifications for product development. Specifications may change in any manner without notice.
Preliminary	First Production	Datasheet contains preliminary data; supplementary data will be published at a later date. Fairchild Semiconductor reserves the right to make changes at any time without notice to improve design.
No Identification Needed	Full Production	Datasheet contains final specifications. Fairchild Semiconductor reserves the right to make changes at any time without notice to improve the design.
Obsolete	Not In Production	Datasheet contains specifications on a product that is discontinued by Fairchild Semiconductor. The datasheet is for reference information only.

Rev. 164