



Chipsmall Limited consists of a professional team with an average of over 10 year of expertise in the distribution of electronic components. Based in Hongkong, we have already established firm and mutual-benefit business relationships with customers from,Europe,America and south Asia,supplying obsolete and hard-to-find components to meet their specific needs.

With the principle of “Quality Parts,Customers Priority,Honest Operation,and Considerate Service”,our business mainly focus on the distribution of electronic components. Line cards we deal with include Microchip,ALPS,ROHM,Xilinx,Pulse,ON,Everlight and Freescale. Main products comprise IC,Modules,Potentiometer,IC Socket,Relay,Connector.Our parts cover such applications as commercial,industrial, and automotives areas.

We are looking forward to setting up business relationship with you and hope to provide you with the best service and solution. Let us make a better world for our industry!



Contact us

Tel: +86-755-8981 8866 Fax: +86-755-8427 6832

Email & Skype: info@chipsmall.com Web: www.chipsmall.com

Address: A1208, Overseas Decoration Building, #122 Zhenhua RD., Futian, Shenzhen, China



FCTE

Pump Dry Running Sensor



The FCTE is a heat sensor, which is attached to the outlet pipe from a pump. This device works by reacting to the temperature at the outlet of any centrifugal type pump, which will rapidly rise past 45 ° if the inlet water level falls below the centre line of the inlet. The unit will cut off the electrical supply to the pump, so protecting it from damage. Manual resetting of this unit allows the pump to restart.

SPECIFICATION	
Set Temperature	45°C 113°F
Switching voltage max.	250Vac
Switching current max. resistive	16A
Pipe diameter range	20-200mm
IP Rating	21

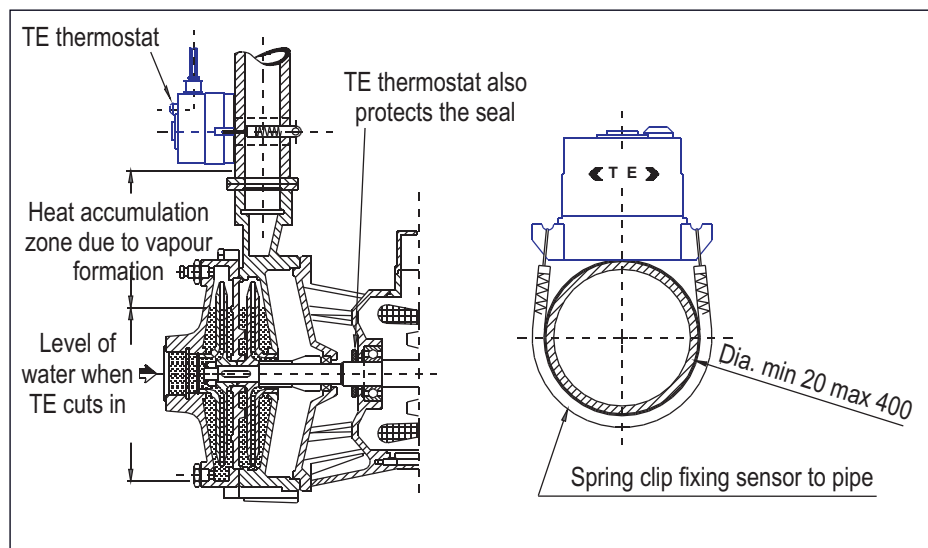

- Prevents dry-running of pump
- Prevents overheating of seals
- High power switching capacity

Cynergy3 Components Ltd
 7 Cobham Road
 Ferndown Industrial Estate
 Wimborne
 Dorset BH21 7PE
 Tel: +44 (0) 1202 897969

sales@cynergy3.com

ISO 9001 CERTIFIED

© 2013 Cynergy3 Components, All Rights Reserved. Specifications are subject to change without prior notice. Cynergy3 Components and the Cynergy3 Components logo are trademarks of Cynergy3 Components Limited.

www.cynergy3.com

FCTE

Pump Dry Running Sensor



INSTALLATION

