



Chipsmall Limited consists of a professional team with an average of over 10 year of expertise in the distribution of electronic components. Based in Hongkong, we have already established firm and mutual-benefit business relationships with customers from,Europe,America and south Asia,supplying obsolete and hard-to-find components to meet their specific needs.

With the principle of "Quality Parts,Customers Priority,Honest Operation,and Considerate Service",our business mainly focus on the distribution of electronic components. Line cards we deal with include Microchip,ALPS,ROHM,Xilinx,Pulse,ON,Everlight and Freescale. Main products comprise IC,Modules,Potentiometer,IC Socket,Relay,Connector.Our parts cover such applications as commercial,industrial, and automotives areas.

We are looking forward to setting up business relationship with you and hope to provide you with the best service and solution. Let us make a better world for our industry!



Contact us

Tel: +86-755-8981 8866 Fax: +86-755-8427 6832

Email & Skype: info@chipsmall.com Web: www.chipsmall.com

Address: A1208, Overseas Decoration Building, #122 Zhenhua RD., Futian, Shenzhen, China



User Guide for
FEBFL7733A_L53U021A

**High PF and Low THD Buck-Boost LED
Driver for 21 W Tube-Type LED Lamp**

**Featured Fairchild Product:
FL7733A**

*Direct questions or comments
about this evaluation board to:
“Worldwide Direct Support”*

Fairchild Semiconductor.com

Table of Contents

1. Introduction	3
1.1. General Description of FL7733A	3
1.2. Controller Features.....	3
1.3. Controller Internal Block Diagram	4
2. General Specifications for Evaluation Board.....	5
3. Evaluation Board.....	6
4. Schematic	7
5. Bill of Materials.....	8
6. Transformer Design.....	9
7. Performance of Evaluation Board	10
7.1. Test Condition & Equipments	10
7.2. Startup.....	11
7.3. Operation Waveforms.....	12
7.4. Constant-Current Regulation	14
7.5. Short / Open-LED Protections	15
7.6. Efficiency	17
7.7. Power Factor (PF) & Total Harmonic Distortion (THD)	18
7.8. Harmonics	19
7.9. Operating Temperature	21
7.10. Electromagnetic Interference (EMI).....	22
8. Revision History	23

This user guide supports the evaluation kit for the FL7733A. It should be used in conjunction with the FL7733A datasheet as well as Fairchild's application notes and technical support team. Please visit Fairchild's website at www.fairchildsemi.com.

1. Introduction

This document describes an universal AC input voltage LED driver designed with buck-boost converter using the FL7733A Primary-Side Regulation (PSR) single-stage controller. The input voltage range is $90 V_{RMS} \sim 277 V_{RMS}$ and there is one DC output with a constant current of 300 mA at 70 V. This document contains a general description of the FL7733A, the power supply solution specification, schematic, bill of materials, and typical operating characteristics.

1.1. General Description of FL7733A

The FL7733A is an active Power Factor Correction (PFC) controller for use in single-stage flyback topology or buck-boost topology. Primary-side regulation and single-stage topology minimize cost by reducing external components such as the input bulk capacitor and secondary side feedback circuitry. To improve Power Factor (PF) and Total Harmonic Distortion (THD), constant on-time control is utilized with an internal error amplifier and a low bandwidth compensator. Precise constant-current control provides accurate output current, independent of input voltage and output voltage. Operating frequency is proportionally changed by the output voltage to guarantee Discontinuous Current Mode (DCM) operation, resulting in high efficiency and simple designs. The FL7733A also provides open-LED, short-LED, and over-temperature protection functions.

1.2. Controller Features

High Performance

- $< \pm 3\%$ Total Constant Current Tolerance Over All Conditions
 - $< \pm 1\%$ Over Universal Line Voltage Variation
 - $< \pm 1\%$ from 50% to 100% Load Voltage Variation
 - $< \pm 1\%$ with $\pm 20\%$ Magnetizing Inductance Variation
- Primary-Side Regulation (PSR) Control for Cost-Effective Solution without Requiring Input Bulk Capacitor and Secondary Feedback Circuitry
- Application Input Voltage Range: $80 V_{AC} - 308 V_{AC}$
- High PF and Low THD Over Universal Line Input Range
- Fast < 200 ms Startup (at $90 V_{AC}$) using Internal High-Voltage Startup with VDD Regulation
- Adaptive Feedback Loop Control for Startup without Overshoot

High Reliability

- LED Short / Open Protection
- Output Diode Short Protection
- Sensing Resistor Short / Open Protection
- V_{DD} Over-Voltage Protection (OVP)
- V_{DD} Under-Voltage Lockout (UVLO)
- Over-Temperature Protection (OTP)
- All Protections by Auto Restart
- Cycle-by-Cycle Current Limit
- Application Voltage Range: $80 V_{AC} \sim 308 V_{AC}$

1.3. Controller Internal Block Diagram

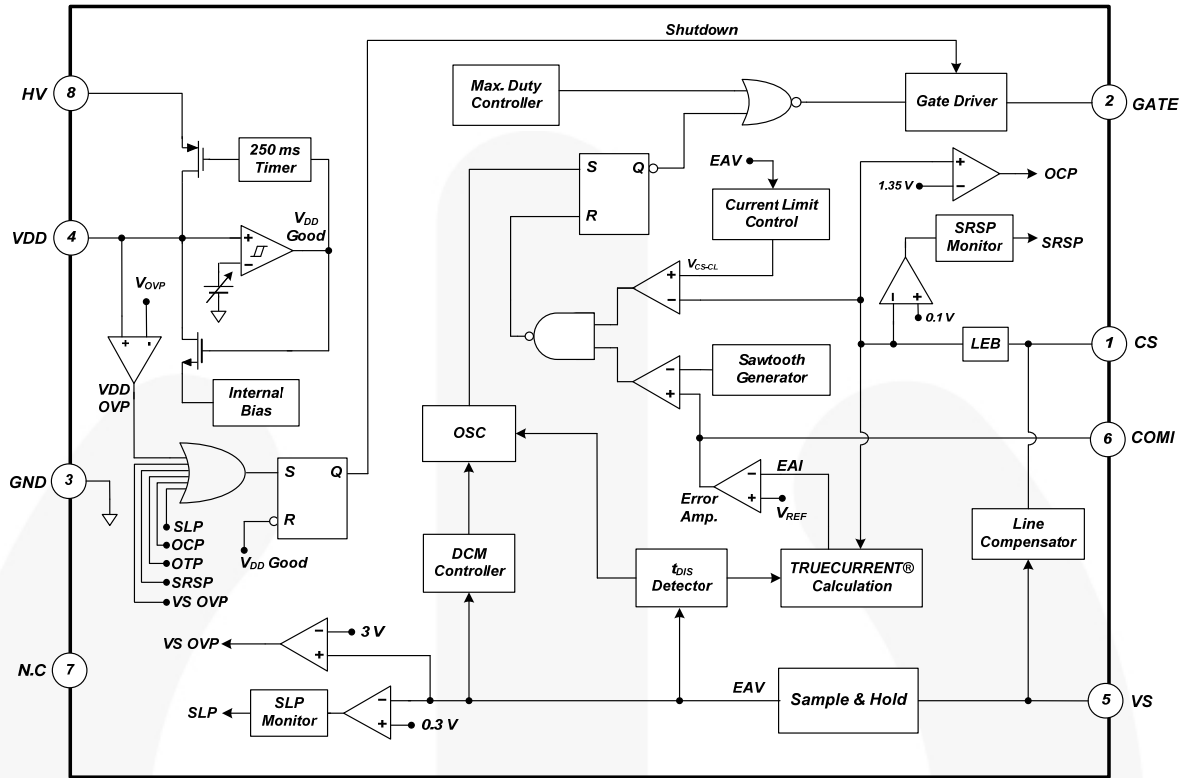

Figure 1. Block Diagram of the FL7733A



2. General Specifications for Evaluation Board

Table 1. Evaluation Board Specifications for LED Lighting Lamp

Description		Symbol	Value	Comments
Input	Voltage	$V_{IN.MIN}$	90 V	Minimum AC Line Input Voltage
		$V_{IN.MAX}$	277 V	Maximum AC Line Input Voltage
		$V_{IN.NOMINAL}$	120 V / 230 V	Nominal AC Line Input Voltage
	Frequency	f_{IN}	60 Hz / 50 Hz	AC Line Frequency
Output	Voltage	$V_{OUT.MIN}$	35 V	Minimum Output Voltage
		$V_{OUT.MAX}$	80 V	Maximum Output Voltage
		$V_{OUT.NOMINAL}$	70 V	Nominal Output Voltage
	Current	$I_{OUT.NOMINAL}$	300 mA	Nominal Output Current
		Max. CC Tolerance	$\pm 0.85\%$ $\pm 0.68\%$	Line Input Voltage Change: 90 ~ 277 V _{AC} Output Voltage Change: 35 ~ 80 V
Efficiency		Eff_{90VAC}	89.72%	Efficiency at 90 V _{AC} Input Voltage
		Eff_{120VAC}	91.63%	Efficiency at 120 V _{AC} Input Voltage
		Eff_{140VAC}	92.28%	Efficiency at 140 V _{AC} Input Voltage
		Eff_{180VAC}	92.97%	Efficiency at 180 V _{AC} Input Voltage
		Eff_{230VAC}	93.24%	Efficiency at 230 V _{AC} Input Voltage
		Eff_{277VAC}	93.20%	Efficiency at 277 V _{AC} Input Voltage
PF/THD		PF / THD _{90 VAC}	0.996 / 8.31%	PF / THD at 90 V _{AC} Input Voltage
		PF / THD _{120 VAC}	0.997 / 5.87%	PF / THD at 120 V _{AC} Input Voltage
		PF / THD _{140 VAC}	0.996 / 4.54%	PF / THD at 140 V _{AC} Input Voltage
		PF / THD _{180 VAC}	0.993 / 4.64%	PF / THD at 180 V _{AC} Input Voltage
		PF / THD _{230 VAC}	0.984 / 6.30%	PF / THD at 230 V _{AC} Input Voltage
		PF / THD _{277 VAC}	0.970 / 8.22%	PF / THD at 277 V _{AC} Input Voltage
Max. Temperature Open-Frame (T _A = 25°C)	Bridge Diode	T _{B-Diode}	49.8°C	Bridge Diode Temperature
	FL7733A	T _{FL7733A}	53.6°C	FL7733A Temperature
	MOSFET	T _{MOSFET}	65.2°C	Main MOSFET Temperature
	Rectifier	T _{Rectifier}	65.8°C	Buck Boost Diode Temperature
	Transformer	T _{TRANS}	53.9°C	Transformer Temperature

All data was measured with the board enclosed in a case and external temperature around 25°C.

3. Evaluation Board

Dimensions: 284 (L) × 17 (W) × 12 (H) [mm]

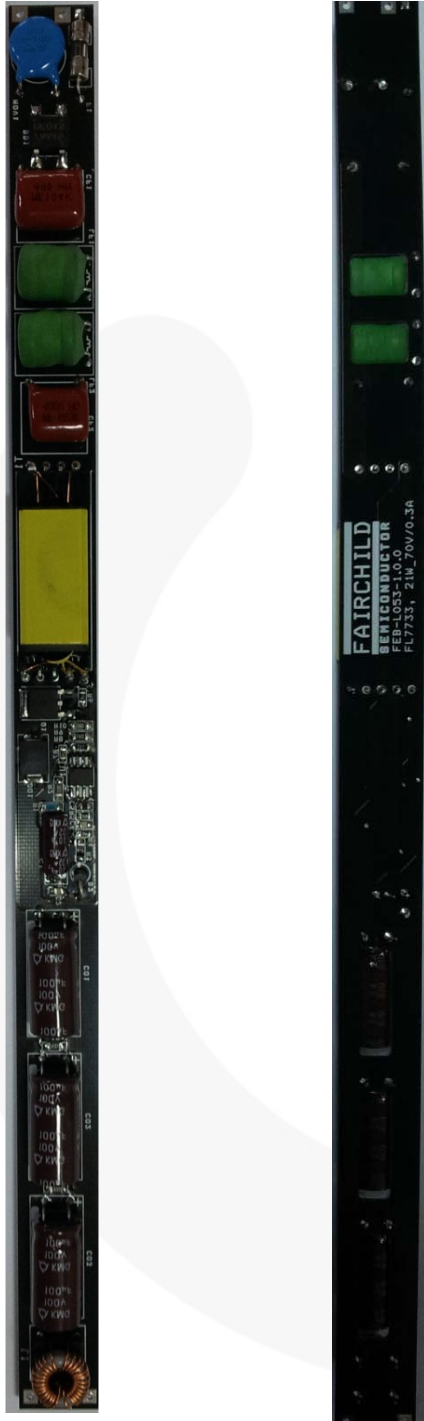

Figure 2. Top / Bottom of Evaluation Board

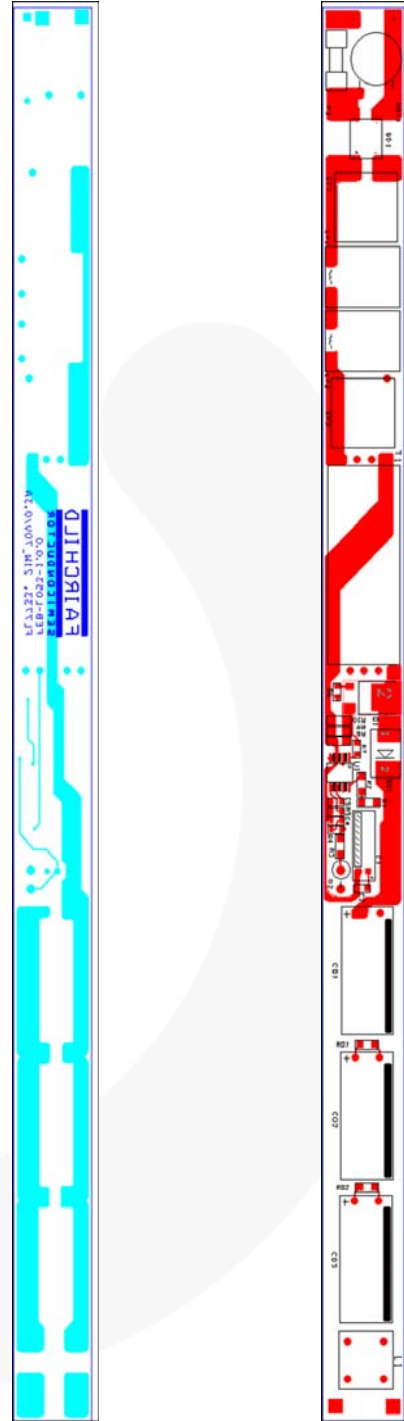

Figure 3. PCB Pattern Top / Bottom of Evaluation Board

4. Schematic

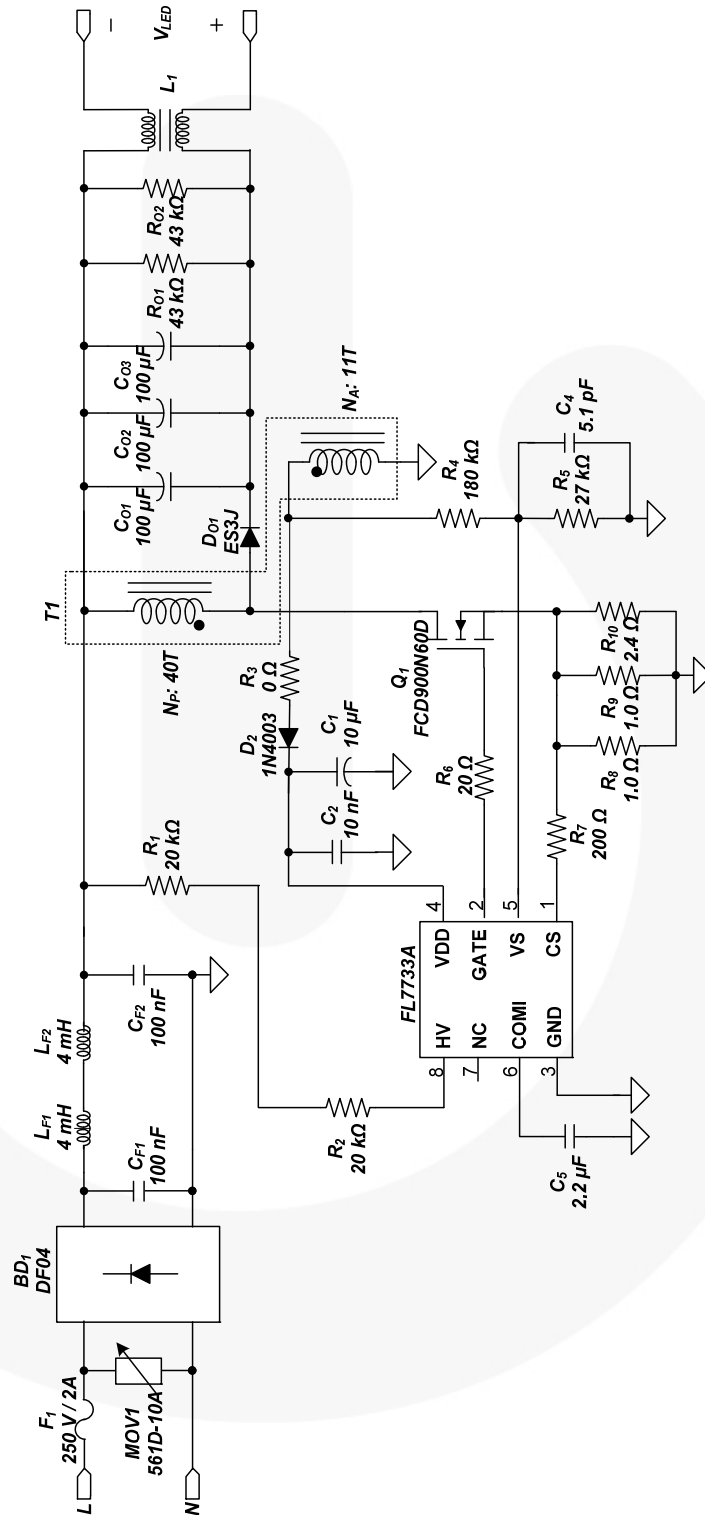

Figure 4. Evaluation Board Schematic



5. Bill of Materials

Item No.	Part Reference	Part Number	Qty.	Description	Manufacturer
1	BD1	DF06S	1	1.5 A / 600 V Bridge Diode	Fairchild Semiconductor
2	CF1, CF2	MPE 400V104K	2	100 nF / 400 V MPE Film Capacitor	Sungho
3	C1	KMG 10 μ F / 35V	1	10 μ F / 35 V Electrolytic Capacitor	Samyoung
4	C2	C0805C104K5RACTU	1	100 nF / 50 V SMD Capacitor 0805	Kemet
5	C4	C0805C519C3GACTU	1	5.1 pF / 25 V, SMD Capacitor 0805	Kemet
6	C5	C0805C225K4RACTU	1	2.2 μ F / 16 V SMD Capacitor 0805	Kemet
7	Co1, Co2, Co3	KMG 100 μ F / 100 V	3	100 μ F / 100 V Electrolytic Capacitor	Samyoung
8	D2	1N4003	1	200 V / 1 A, General Purpose Rectifier	Fairchild Semiconductor
9	Do1	ES3J	1	600 V / 3 A, Fast Rectifier	Fairchild Semiconductor
10	F1	0672002.MXE	1	2 A / 250 V, Fuse	Littelfuse
11	LF1, LF2	R10402KT00	2	4 mH Inductor, 10 \emptyset	Hanamelec
12	L1	LF10S-501-2A	1	500 μ H Common Choke	Hanamelec
13	MOV1	SVC 561D-10A	1	Metal Oxide Varistor	Samwha
14	Q1	FCD900N60Z	1	4.5 A / 600 V Main MOSFET	Fairchild Semiconductor
15	R1, R2	RC1206JR-0720KL	2	20 k Ω SMD Resistor 1206	Yageo
16	R3	RC1206JR-070RL	1	0 Ω SMD Resistor 1206	Yageo
17	R4	RC0805FR-07150RL	1	180 k Ω SMD Resistor 0805	Yageo
18	R5	RC0805FR-0724RL	1	27 k Ω SMD Resistor 0805	Yageo
19	R6	RC0805JR-0720RL	1	20 Ω SMD Resistor 0805	Yageo
20	R7	RC0805JR-07200RL	1	200 Ω SMD Resistor 0805	Yageo
21	R8, R9	RC1206JR-071R0L	2	1.0 Ω SMD Resistor 1206	Yageo
22	R10	RC1206JR-072R4L	1	2.4 Ω SMD Resistor 1206	Yageo
23	Ro1, Ro2	RC1206JR-0743kL	2	43 k Ω SMD Resistor 1206	Yageo
24	T1	EEW1328	1	Transformer, 450 μ H	Sejin-Electronics
25	U1	FL7733AMX	1	Single Stage PSR Controller	Fairchild Semiconductor

6. Transformer Design

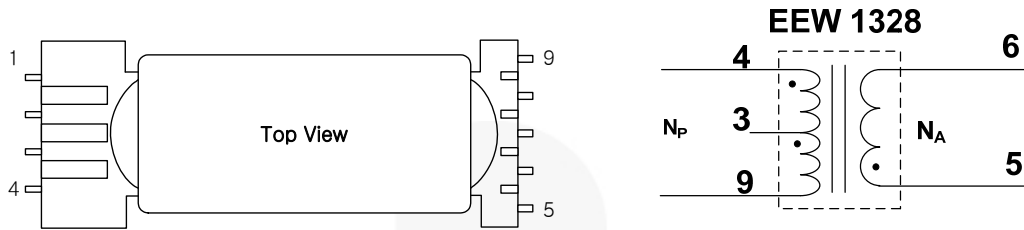

Figure 5. Transformer Bobbin Structure and Pin Configuration

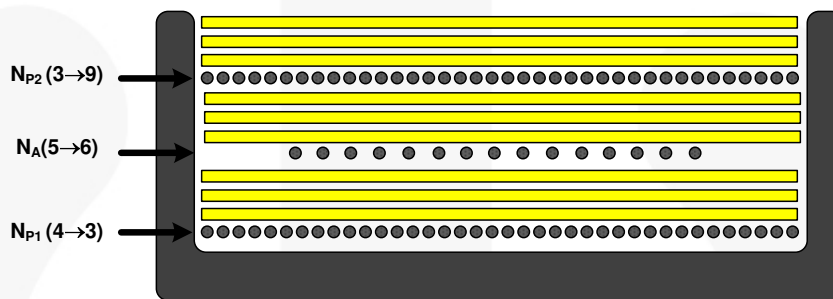

Figure 6. Transformer Winding Structure

Table 2. Winding Specifications

No	Winding	Pin (S → F)	Wire	Turns	Winding Method
1	N_{P1}	4 → 3	0.33 \emptyset	22 Ts	Solenoid Winding
2	Insulation: Polyester Tape t = 0.025 mm, 3-Layer				
3	N_A	5 → 6	0.25 \emptyset [TIW]	11 Ts	Solenoid Winding
4	Insulation: Polyester Tape t = 0.025 mm, 3 Layer				
5	N_{P2}	3 → 9	0.33 \emptyset	18 Ts	Solenoid Winding
6	Insulation: Polyester Tape t = 0.025 mm, 3-Layer				

Table 3. Electrical Characteristics

	Pin	Spec.	Remark
Inductance	4-9	450 μ H \pm 10%	60 kHz, 1 V
Leakage		Max. 5 μ H	60 kHz, 1 V Short All Output Pins

7. Performance of Evaluation Board

7.1. Test Condition & Equipments

Ambient Temperature	T_A = 25°C
Test Equipment	AC Power Source: PCR500L by Kikusui Power Analyzer: PZ4000 by YOKOGAWA Oscilloscope: WaveRunner 104Xi by LeCroy EMI Test Receiver: ESCS30 by ROHDE & SCHWARZ Two-Line V-Network: ENV216 by ROHDE & SCHWARZ Thermometer: Therma CAM SC640 by FLIR SYSTEMS LED: EHP-AX08EL/GT01H-P03(3W) by Everlight

7.2. Startup

Figure 7 and Figure 8 show the overall startup performance at rated output load. The output current of buck boost converter starts flowing after about 0.2 s and 0.13 s for input voltage 90 V_{AC} and 277 V_{AC} condition when the AC input power switch turns on; CH1: V_{DD} (10 V / div), CH2: V_{IN} (100 V / div), CH3: V_{OUT} (50 V / div), CH4: I_{OUT} (200 mA / div), Time Scale: (100 ms / div), Load: 4 parallel * 24 series-LEDs.

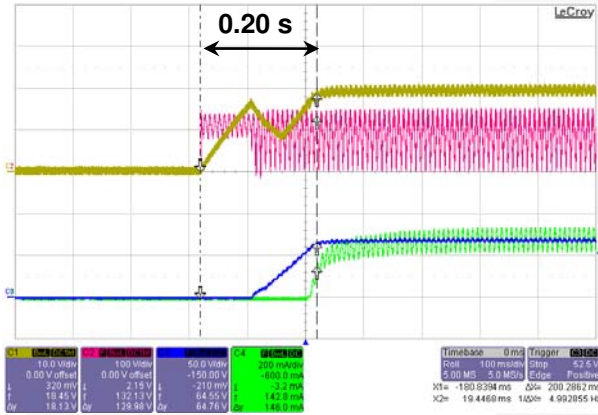

Figure 7. V_{IN} = 90 V_{AC} / 60 Hz

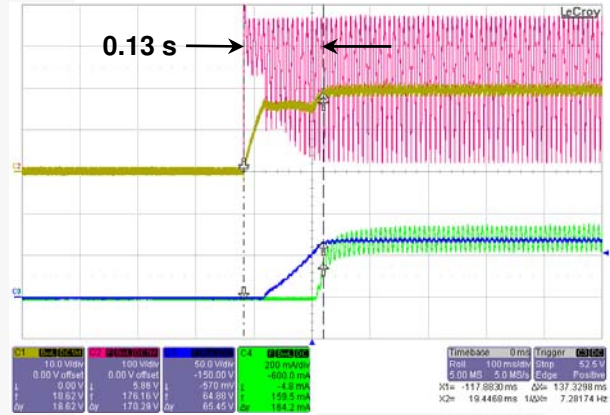

Figure 8. V_{IN} = 277 V_{AC} / 50 Hz

7.3. Operation Waveforms

Figure 9 to Figure 12 show AC input and output waveforms at rated output load. CH1: I_{IN} (500 mA / div), CH2: V_{IN} (100 V / div), CH3: V_{OUT} (20 V / div), CH4: I_{OUT} (200 mA / div), Time Scale: (5 ms / div), Load: 4 parallel * 24 series-LEDs.

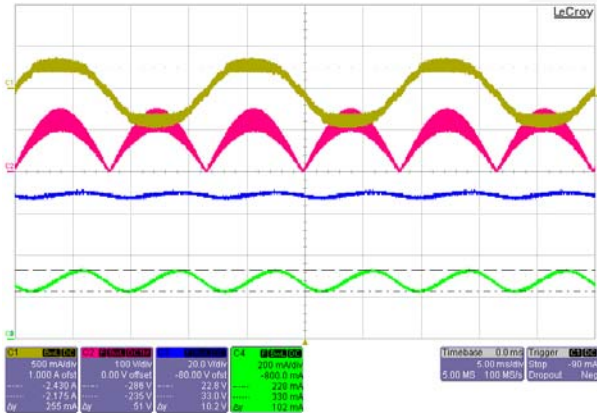

Figure 9. $V_{IN} = 90 V_{AC} / 60 Hz$

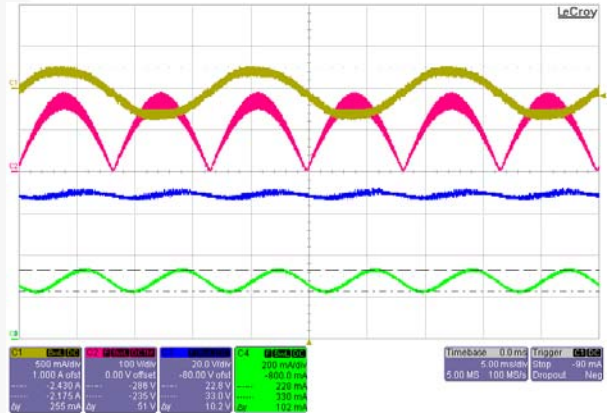

Figure 10. $V_{IN} = 120 V_{AC} / 60 Hz$

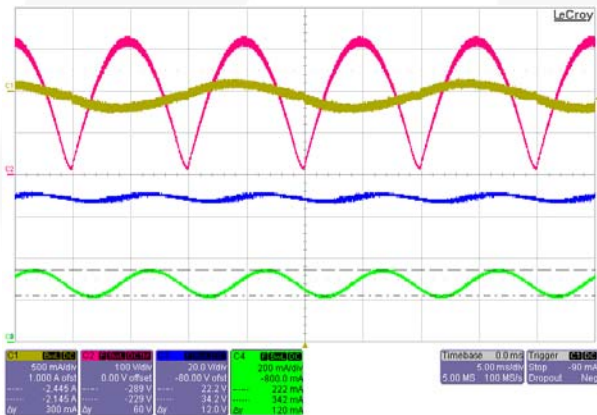

Figure 11. $V_{IN} = 230 V_{AC} / 50 Hz$

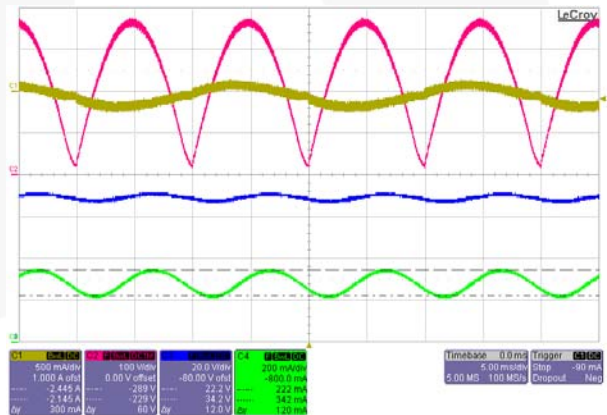

Figure 12. $V_{IN} = 277 V_{AC} / 50 Hz$

Figure 13 to Figure 16 show key waveforms of single stage buck boost converter operation for line voltages at rated output load. CH1: I_{DS} (1.00 A / div), CH2: $V_{Buck/Boost-Diode}$ (200 V / div), CH3: V_{DS} (200 V / div), CH4: $I_{Buck/Boost-Diode}$ (1.00 A / div), Load: 4 parallel * 24 series-LEDs.

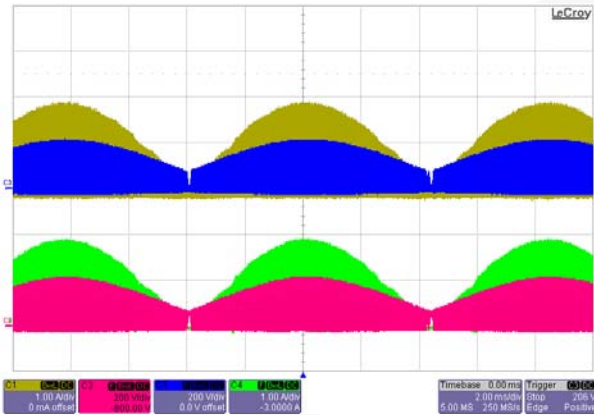

Figure 13. $V_{IN} = 90 V_{AC} / 60 Hz$, [2.0 ms / div]

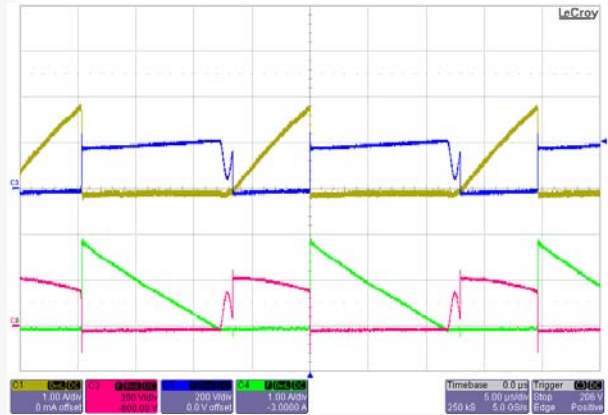

Figure 14. $V_{IN} = 90 V_{AC} / 60 Hz$, [5.0 μs / div]

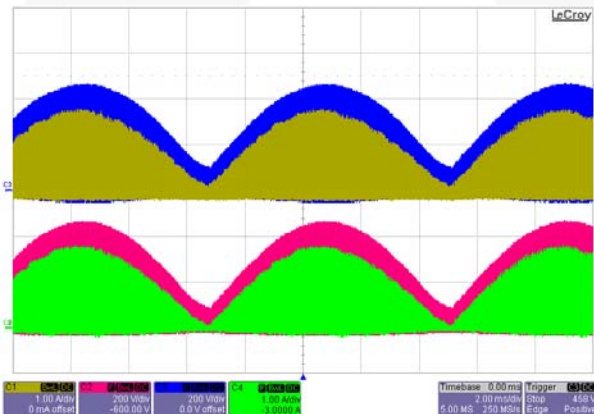

Figure 15. $V_{IN} = 277 V_{AC} / 60 Hz$, [2.0 ms / div]

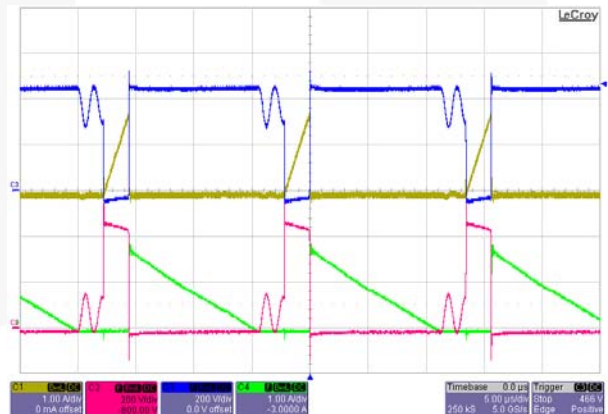

Figure 16. $V_{IN} = 277 V_{AC} / 60 Hz$, [5.0 μs / div]

7.4. Constant-Current Regulation

Constant-current deviation in the wide output voltage range from 35 V to 80 V is less than $\pm 0.68\%$ at each line input voltage. Line regulation is less than $\pm 0.85\%$. The results were measured using E-load [CR Mode].

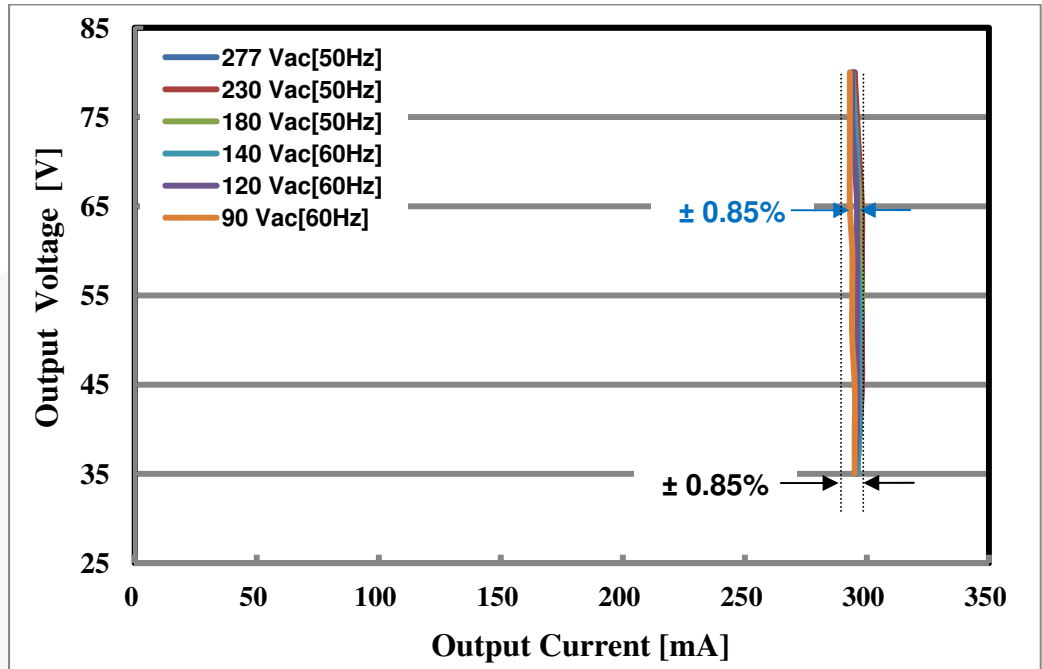

Figure 17. Constant-Current Regulation – Measured by E-Load

Table 4. Constant-Current Regulation by Output Voltage Change (35 V ~ 80 V)

Input Voltage	Min. Current	Max. Current	Tolerance
90 V _{AC} [60Hz]	293 mA	295 mA	$\pm 0.51\%$
120 V _{AC} [60Hz]	294 mA	296 mA	$\pm 0.51\%$
140 V _{AC} [60Hz]	294 mA	297 mA	$\pm 0.68\%$
180 V _{AC} [50Hz]	294 mA	298 mA	$\pm 0.51\%$
230 V _{AC} [50Hz]	295 mA	298 mA	$\pm 0.34\%$
277 V _{AC} [50Hz]	295 mA	298 mA	$\pm 0.34\%$

Table 5. Constant-Current Regulation by Line Voltage Change (90 ~ 277 V_{AC})

Output Voltage	90 V _{AC} [60 Hz]	120 V _{AC} [60 Hz]	140 V _{AC} [60 Hz]	180 V _{AC} [50 Hz]	230 V _{AC} [50 Hz]	277 V _{AC} [50 Hz]	Tolerance
75 V	293 mA	294 mA	296 mA	295 mA	296 mA	295 mA	$\pm 0.51\%$
70 V	293 mA	295 mA	296 mA	296 mA	297 mA	296 mA	$\pm 0.68\%$
65 V	293 mA	296 mA	296 mA	297 mA	298 mA	297 mA	$\pm 0.85\%$

7.5. Short / Open-LED Protections

Figure 18 to Figure 21 show waveforms for protections operated when the LED is shorted and recovered. Once the LED short occurs, SCP is triggered and VDD starts hiccup mode with JFET regulation times [250 ms]. This lasts until the fault condition is eliminated. Systems can restart automatically when returned to normal condition. ; CH1: V_{DD} (10 V / div), CH2: V_{IN} (100 V / div), CH3: V_{GATE} (10 V / div), I_{OUT} (200 mA / div), Time Scale: (0.5 s / div).

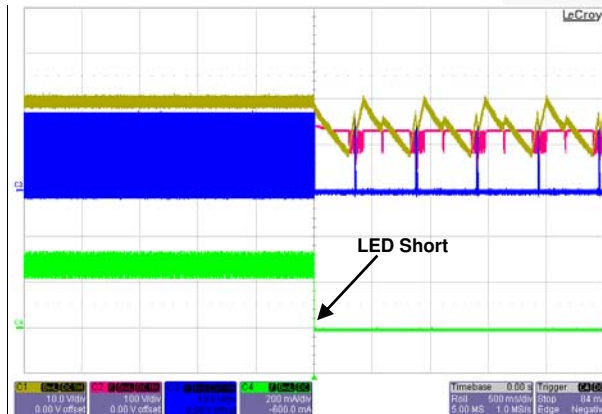

Figure 18. V_{IN} = 90 V_{AC} / 60 Hz, [LED Short]

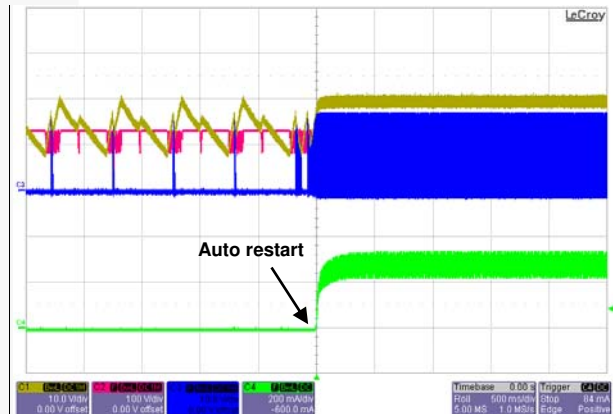

Figure 19. V_{IN} = 90 V_{AC} / 60 Hz, [LED Restore]

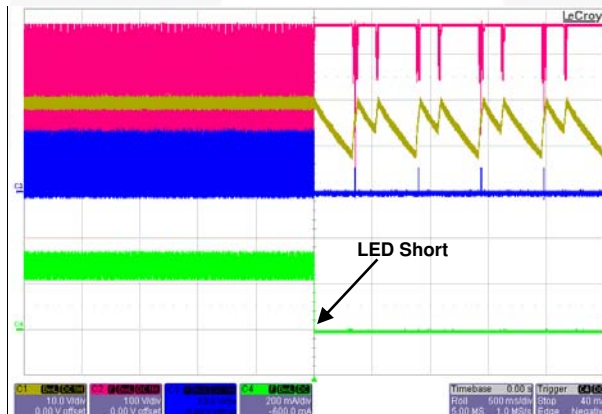

Figure 20. V_{IN} = 277 V_{AC} / 50 Hz, [LED Short]

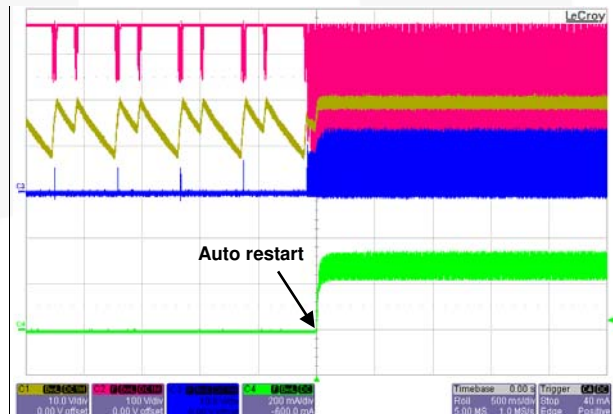

Figure 21. V_{IN} = 277 V_{AC} / 50 Hz, [LED Restore]

Figure 22 to Figure 25 show waveforms for protections operated when the LED is opened and recovered. Once the LED has opened, VS OVP or VDD OVP are triggered and VDD starts hiccup mode with JFET regulation times [250 ms]. This lasts until the fault condition is eliminated. Systems can restart automatically when returned to normal condition. CH1: V_{DD} (10 V / div), CH2: V_{IN} (100 V / div), CH3: V_{GATE} (10 V / div), V_{OUT} (50 V / div), Time Scale: (0.5 s / div).

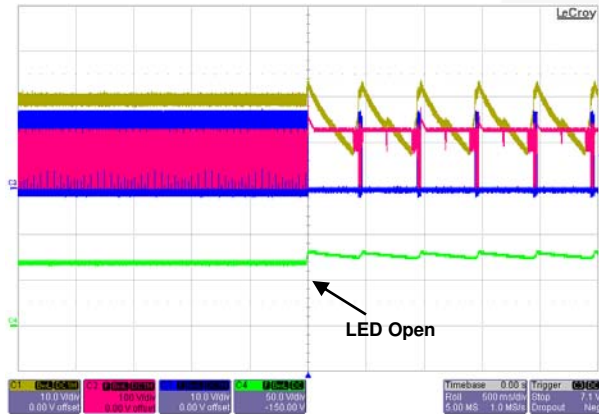

Figure 22. $V_{IN} = 90 V_{AC} / 60 Hz$, [LED Open]

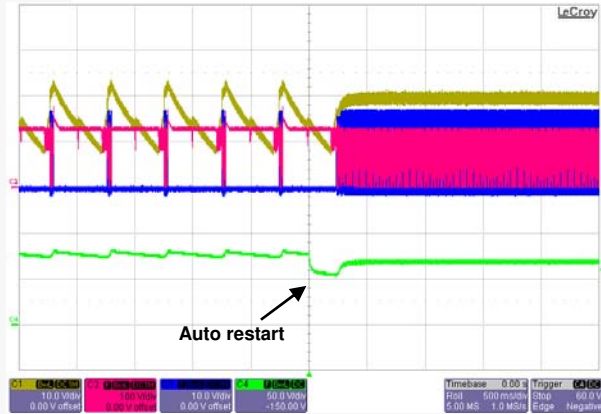

Figure 23. $V_{IN} = 90 V_{AC} / 60 Hz$, [LED Restore]

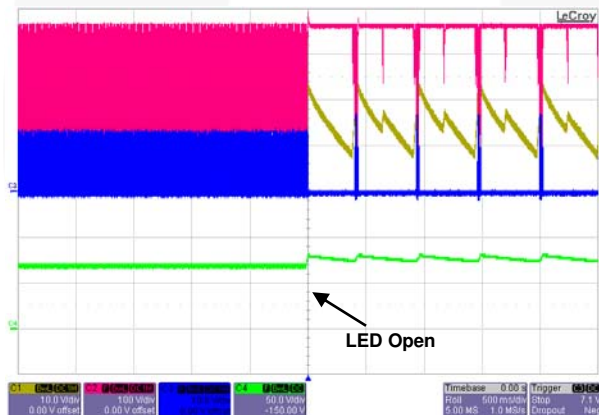

Figure 24. $V_{IN} = 277 V_{AC} / 50 Hz$, [LED Open]

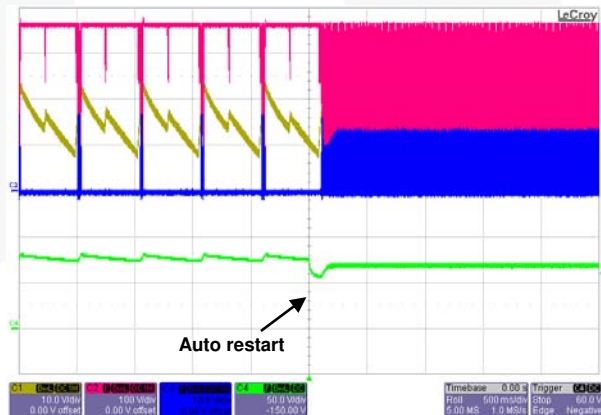

Figure 25. $V_{IN} = 277 V_{AC} / 50 Hz$, [LED Restore]

Note:

1. When the LED load is re-connected after open-LED condition, the output capacitor is quickly discharged through the LED load and the inrush current by the discharge could destroy the LED load.

7.6. Efficiency

System efficiency is 89.72% ~ 93.24% over input voltages 90 ~ 277 V_{AC}. The results were measured using actual rated LED loads at 30 minutes after startup.

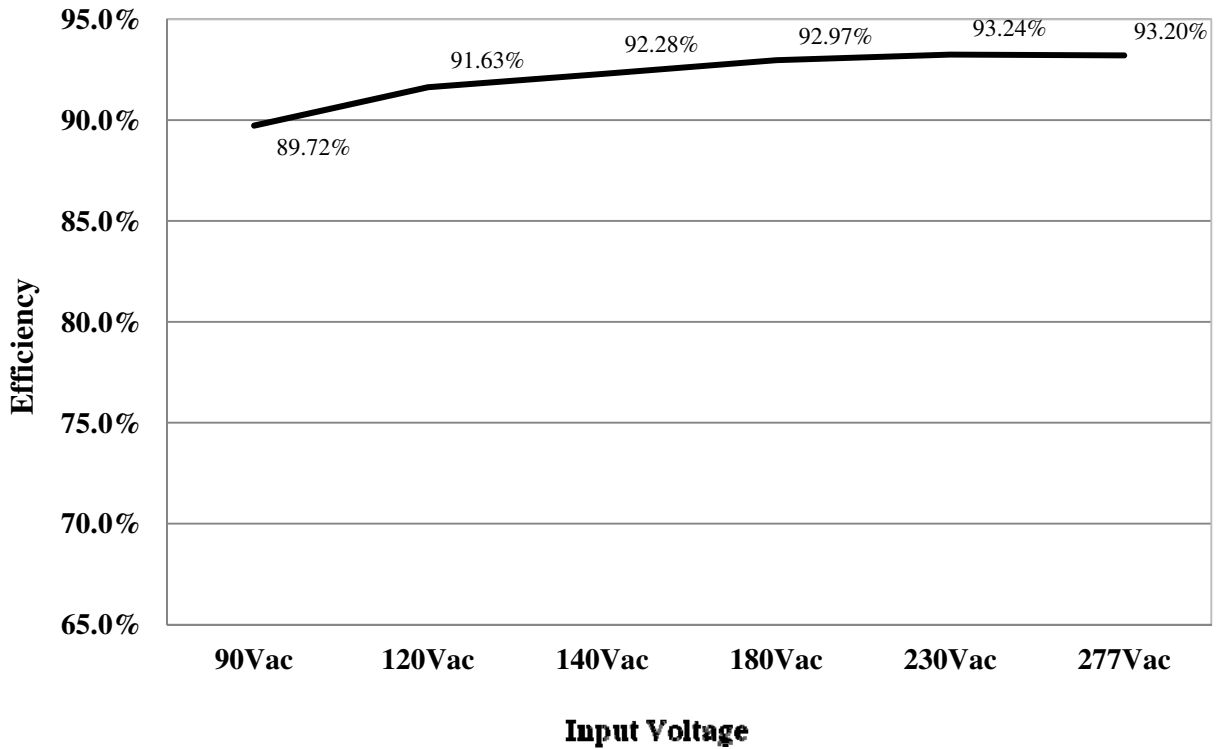

Figure 26. System Efficiency

Table 6. System Efficiency

Input Voltage	Input Power [W]	Output Current [mA]	Output Voltage [V]	Output Power [W]	Efficiency
90 V _{AC} [60 Hz]	22.23	0.284	70.33	19.95	89.72%
120 V _{AC} [60 Hz]	21.86	0.285	70.33	20.03	91.63%
140 V _{AC} [60 Hz]	21.74	0.285	70.32	20.06	92.28%
180 V _{AC} [50 Hz]	21.73	0.287	70.34	20.20	92.97%
230 V _{AC} [50 Hz]	21.76	0.288	70.35	20.29	93.24%
277 V _{AC} [50 Hz]	21.84	0.289	70.36	20.36	93.20%

7.7. Power Factor (PF) & Total Harmonic Distortion (THD)

The FL7733A evaluation board shows excellent PF and THD performance. THD is less than 10%. The results were measured using actual rated LED loads at 10 minutes after startup.

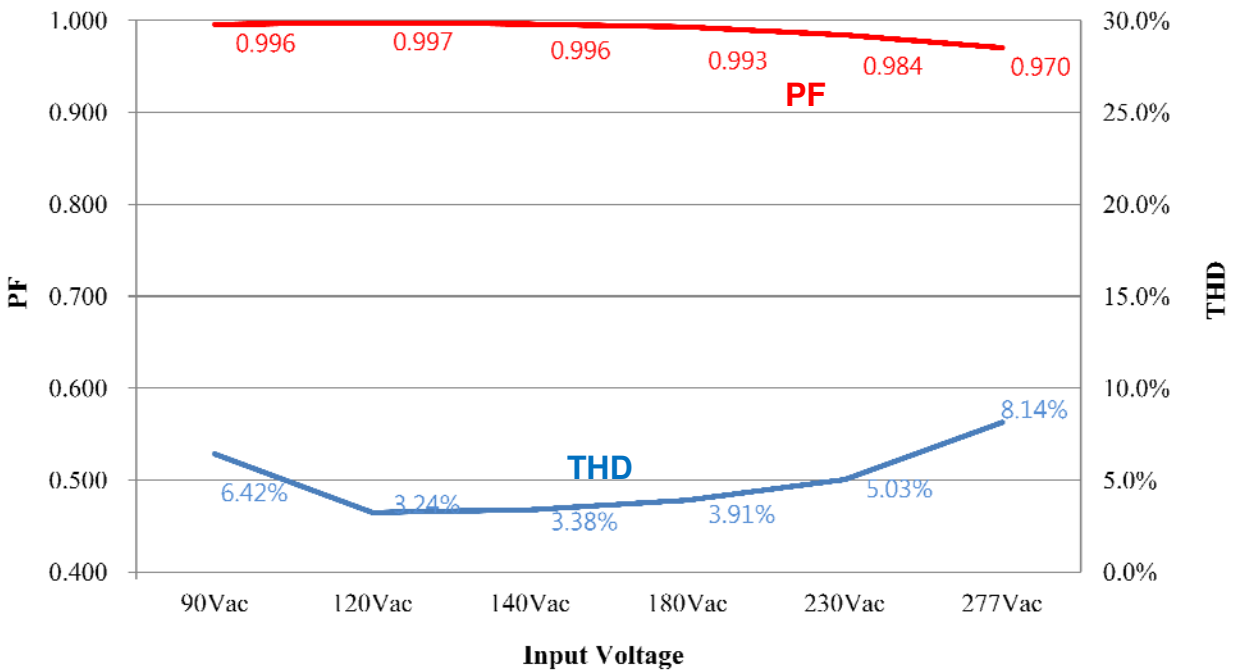

Figure 27. Power Factor & Total Harmonic Distortion

Table 7. Power Factor & Total Harmonic Distortion

Input Voltage	Output Current [mA]	Output Voltage [V]	PF	THD
90 V _{AC} [60 Hz]	0.284	70.33	0.996	8.31%
120 V _{AC} [60 Hz]	0.285	70.33	0.997	5.87%
140 V _{AC} [60 Hz]	0.285	70.32	0.996	4.54%
180 V _{AC} [50 Hz]	0.287	70.34	0.993	4.64%
230 V _{AC} [50 Hz]	0.288	70.35	0.984	6.30%
277 V _{AC} [50 Hz]	0.289	70.36	0.970	8.22%

7.8. Harmonics

Figure 28 to Figure 31 show current harmonics measured using actual rated LED loads.

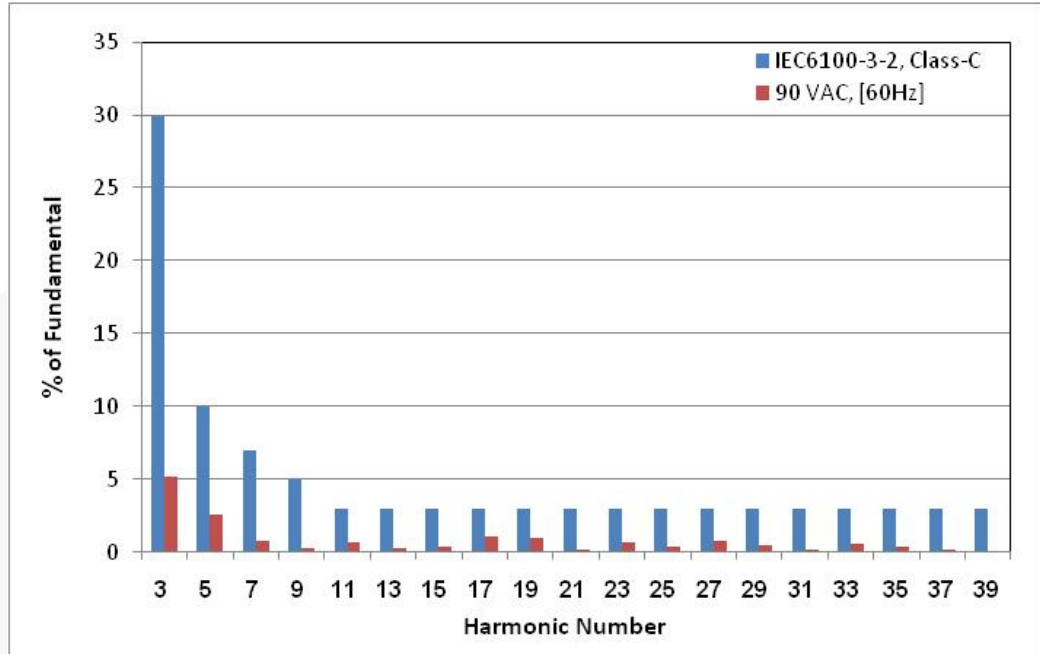

Figure 28. $V_{IN} = 90 V_{AC} / 60 \text{ Hz}$

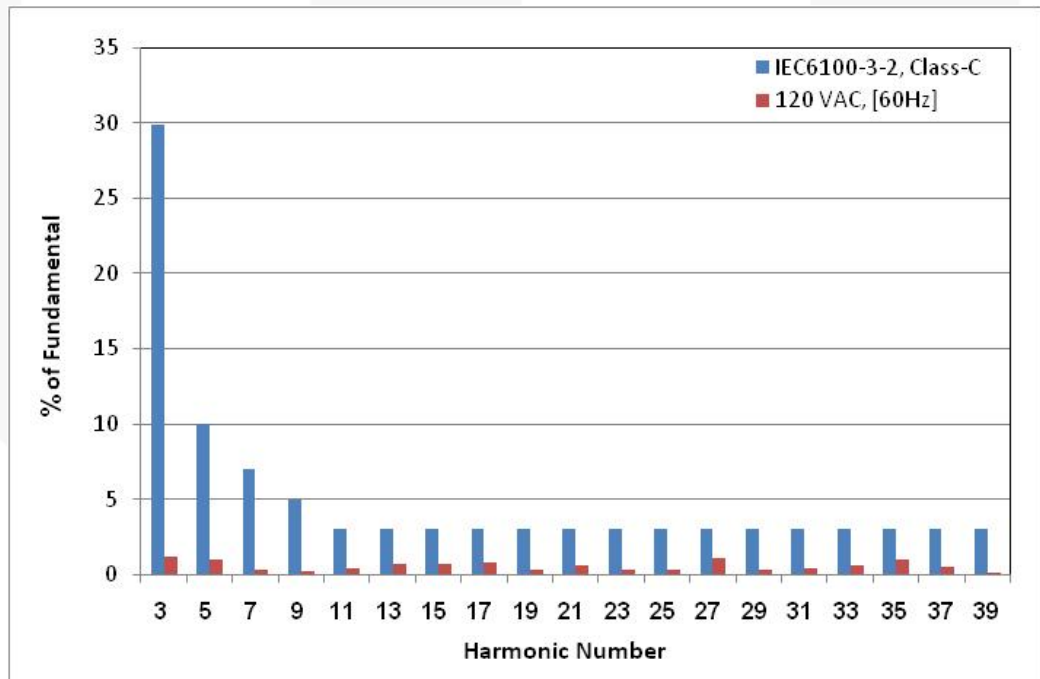

Figure 29. $V_{IN} = 120 V_{AC} / 60 \text{ Hz}$

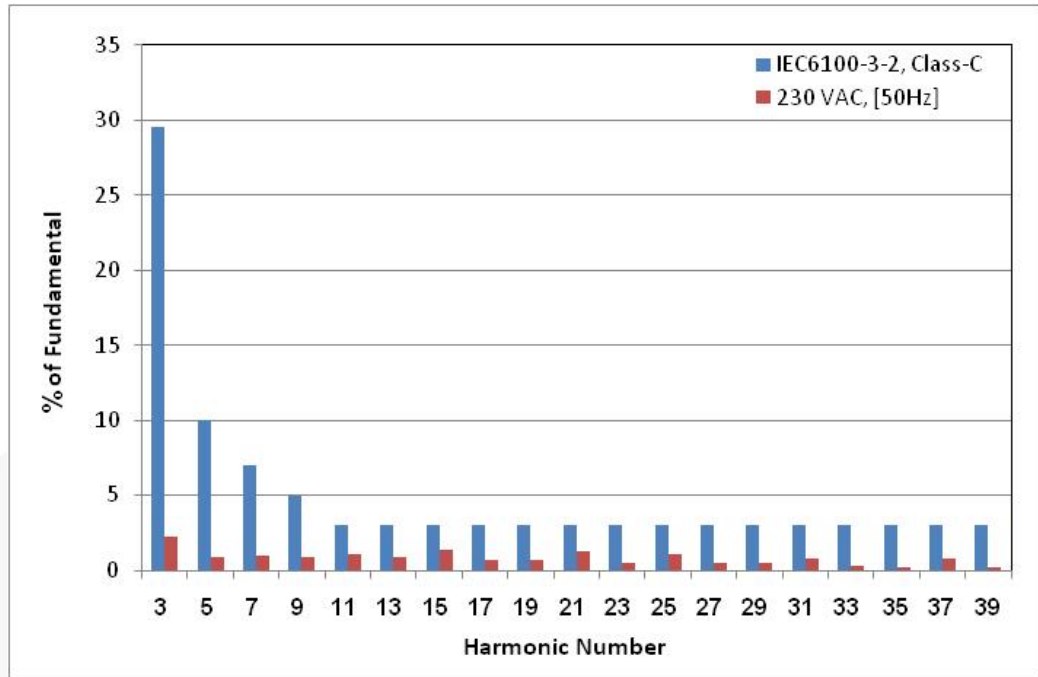

Figure 30. $V_{IN} = 230 V_{AC} / 50 \text{ Hz}$

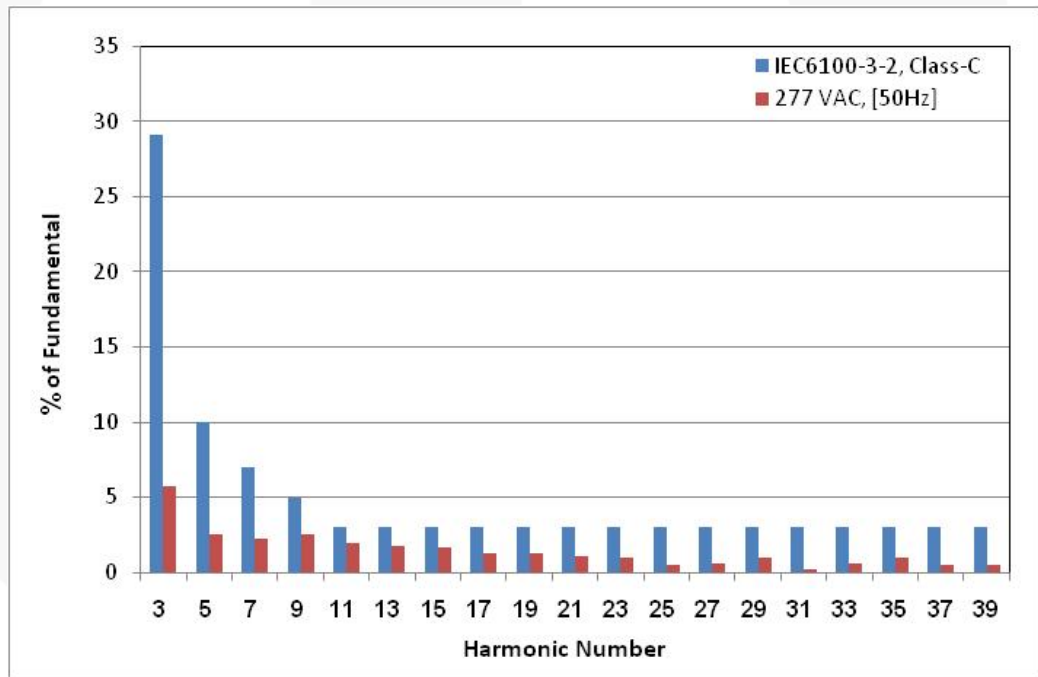

Figure 31. $V_{IN} = 277 V_{AC} / 50 \text{ Hz}$

7.9. Operating Temperature

The results were measured using actual rated LED loads 60 minutes after startup.

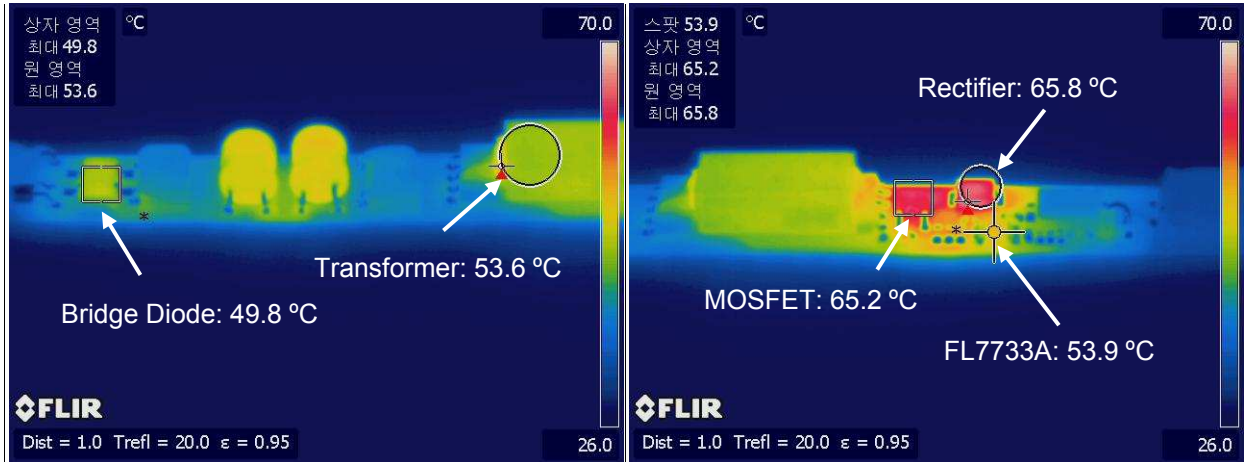

Figure 32. $V_{IN} = 90 V_{AC} / 60 Hz$

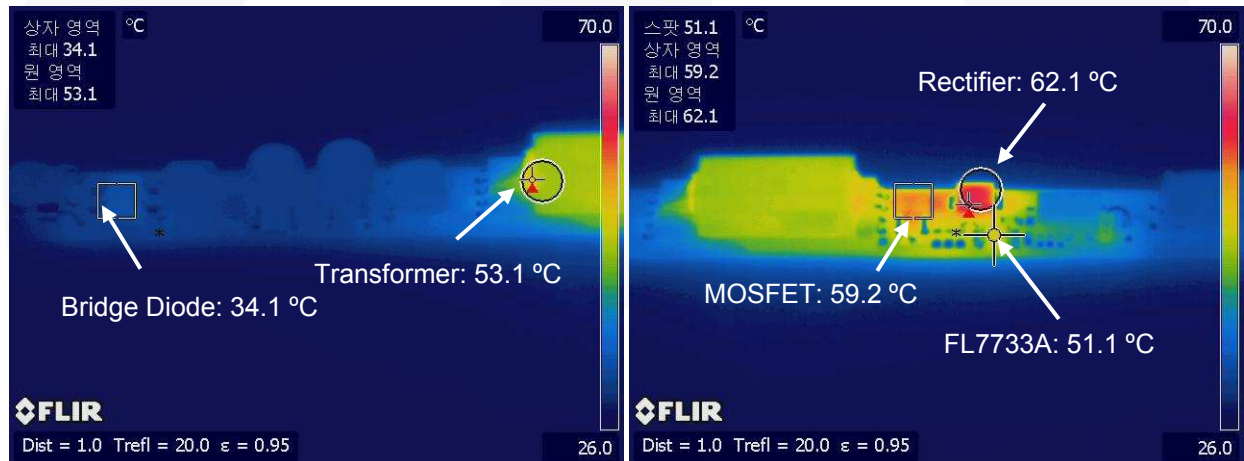

Figure 33. $V_{IN} = 277 V_{AC} / 50 Hz$

Note:

- The IC temperature can be improved by the PCB layout.

7.10. Electromagnetic Interference (EMI)

All measurements were conducted in observance of EN55022 criteria.

The results were measured using actual rated LED loads 30 minutes after startup.

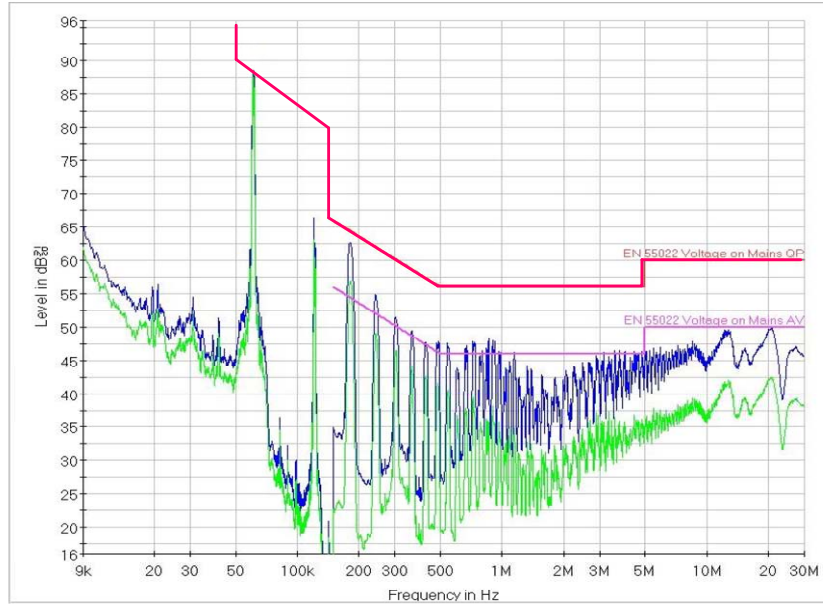

Figure 34. V_{IN} [110 V_{AC}, Neutral]

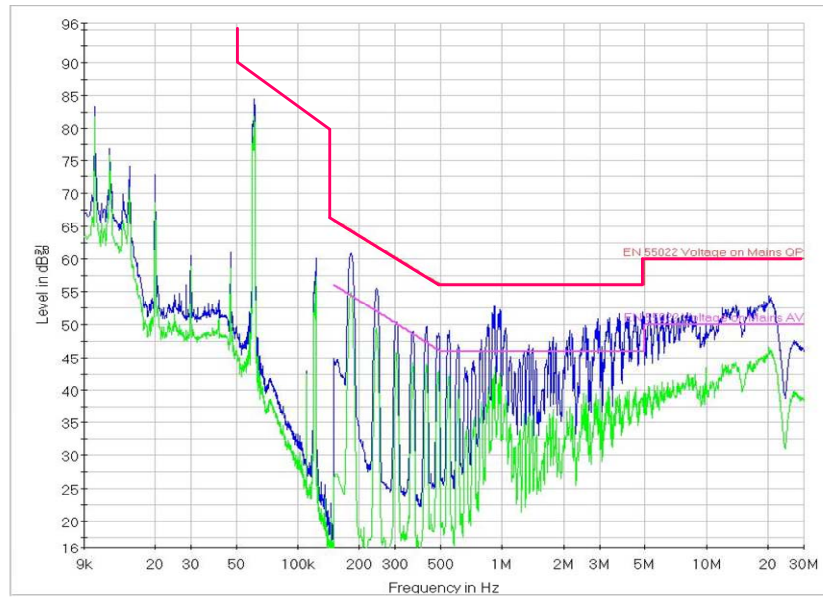

Figure 35. V_{IN} [220 V_{AC}, Live]



8. Revision History

Rev.	Date	Description
1.0	Oct.2014	Initial Release

WARNING AND DISCLAIMER

Replace components on the Evaluation Board only with those parts shown on the parts list (or Bill of Materials) in the Users' Guide. Contact an authorized Fairchild representative with any questions.

The Evaluation board (or kit) is for demonstration purposes only and neither the Board nor this User's Guide constitute a sales contract or create any kind of warranty, whether express or implied, as to the applications or products involved. Fairchild warrants that its products meet Fairchild's published specifications, but does not guarantee that its products work in any specific application. Fairchild reserves the right to make changes without notice to any products described herein to improve reliability, function, or design. Either the applicable sales contract signed by Fairchild and Buyer or, if no contract exists, Fairchild's standard Terms and Conditions on the back of Fairchild invoices, govern the terms of sale of the products described herein.

DISCLAIMER

FAIRCHILD SEMICONDUCTOR RESERVES THE RIGHT TO MAKE CHANGES WITHOUT FURTHER NOTICE TO ANY PRODUCTS HEREIN TO IMPROVE RELIABILITY, FUNCTION, OR DESIGN. FAIRCHILD DOES NOT ASSUME ANY LIABILITY ARISING OUT OF THE APPLICATION OR USE OF ANY PRODUCT OR CIRCUIT DESCRIBED HEREIN; NEITHER DOES IT CONVEY ANY LICENSE UNDER ITS PATENT RIGHTS, NOR THE RIGHTS OF OTHERS.

LIFE SUPPORT POLICY

FAIRCHILD'S PRODUCTS ARE NOT AUTHORIZED FOR USE AS CRITICAL COMPONENTS IN LIFE SUPPORT DEVICES OR SYSTEMS WITHOUT THE EXPRESS WRITTEN APPROVAL OF THE PRESIDENT OF FAIRCHILD SEMICONDUCTOR CORPORATION.

As used herein:

1. Life support devices or systems are devices or systems which, (a) are intended for surgical implant into the body, or (b) support or sustain life, or (c) whose failure to perform when properly used in accordance with instructions for use provided in the labeling, can be reasonably expected to result in significant injury to the user.
2. A critical component is any component of a life support device or system whose failure to perform can be reasonably expected to cause the failure of the life support device or system, or to affect its safety or effectiveness.

ANTI-COUNTERFEITING POLICY

Fairchild Semiconductor Corporation's Anti-Counterfeiting Policy. Fairchild's Anti-Counterfeiting Policy is also stated on our external website, www.fairchildsemi.com, under Sales Support.

Counterfeiting of semiconductor parts is a growing problem in the industry. All manufacturers of semiconductor products are experiencing counterfeiting of their parts. Customers who inadvertently purchase counterfeit parts experience many problems such as loss of brand reputation, substandard performance, failed applications, and increased cost of production and manufacturing delays. Fairchild is taking strong measures to protect ourselves and our customers from the proliferation of counterfeit parts. Fairchild strongly encourages customers to purchase Fairchild parts either directly from Fairchild or from Authorized Fairchild Distributors who are listed by country on our web page cited above. Products customers buy either from Fairchild directly or from Authorized Fairchild Distributors are genuine parts, have full traceability, meet Fairchild's quality standards for handling and storage and provide access to Fairchild's full range of up-to-date technical and product information. Fairchild and our Authorized Distributors will stand behind all warranties and will appropriately address any warranty issues that may arise. Fairchild will not provide any warranty coverage or other assistance for parts bought from Unauthorized Sources. Fairchild is committed to combat this global problem and encourage our customers to do their part in stopping this practice by buying direct or from authorized distributors.