



Chipsmall Limited consists of a professional team with an average of over 10 year of expertise in the distribution of electronic components. Based in Hongkong, we have already established firm and mutual-benefit business relationships with customers from,Europe,America and south Asia,supplying obsolete and hard-to-find components to meet their specific needs.

With the principle of “Quality Parts,Customers Priority,Honest Operation,and Considerate Service”,our business mainly focus on the distribution of electronic components. Line cards we deal with include Microchip,ALPS,ROHM,Xilinx,Pulse,ON,Everlight and Freescale. Main products comprise IC,Modules,Potentiometer,IC Socket,Relay,Connector.Our parts cover such applications as commercial,industrial, and automotives areas.

We are looking forward to setting up business relationship with you and hope to provide you with the best service and solution. Let us make a better world for our industry!



Contact us

Tel: +86-755-8981 8866 Fax: +86-755-8427 6832

Email & Skype: info@chipsmall.com Web: www.chipsmall.com

Address: A1208, Overseas Decoration Building, #122 Zhenhua RD., Futian, Shenzhen, China



User Guide for
FEBFOD8332
FEBFOD8333
Evaluation Board

**Input LED Drive, 2.5 A Output Current,
IGBT Drive Optocoupler with Desaturation
Detection, Isolated Fault Sensing, and
Active Miller Clamp**

Featured Fairchild Products:

FOD8332

FOD8333

*Direct questions or comments
about this evaluation board to:
“Worldwide Direct Support”*

Fairchild Semiconductor.com

Table of Contents

1. Overview.....	3
1.1. Features and Benefits	4
1.2. Applications	5
2. Operations.....	6
3. Circuit Schematic.....	8
4. Setup and Operation.....	10
5. Test Procedures and Conditions.....	10
6. Scope Shots.....	12
7. Conclusion	14
8. Revision History	14

This user guide supports the evaluation kit for the [FOD8332](#) and [FOD8333](#). It should be used in conjunction with the FOD8332 and FOD8333 datasheets as well as Fairchild's application notes and technical support team. Please visit Fairchild's website at www.fairchildsemi.com.

1. Overview

Fairchild FOD833x smart gate driver optocoupler, an advanced 2.5 A output current IGBT drive optocoupler, offers the critical protection necessary for preventing fault conditions that lead to destructive thermal runaway of IGBTs. Pin-for-pin compatible with current solutions, the FOD833x consists of an integrated gate drive optocoupler featuring low $R_{DS(ON)}$ CMOS transistors to drive the IGBT from rail-to-rail and high-speed isolated feedback circuitry for fault sensing. It is ideally suited for driving fast-switching power IGBTs and MOSFETs. FOD833x herein refers to FOD8332 or FOD8333. The key difference between these two products is the reset mechanism. The FAULT signal is reset when V_{LED1+} is pulled from LOW to HIGH for FOD8332 or automatically after $t_{DESAT(MUTE)}$ for FOD8333.

The FOD833x offers best-in-class noise immunity, resulting from its proprietary Optoplanar[®] coplanar packaging technology. The optoplanar technology ensures safe insulation thickness of more than 0.4 mm in attaining reliable high-voltage isolation, certified by UL1577 and DIN EN/IEC60747-5-5 standards.

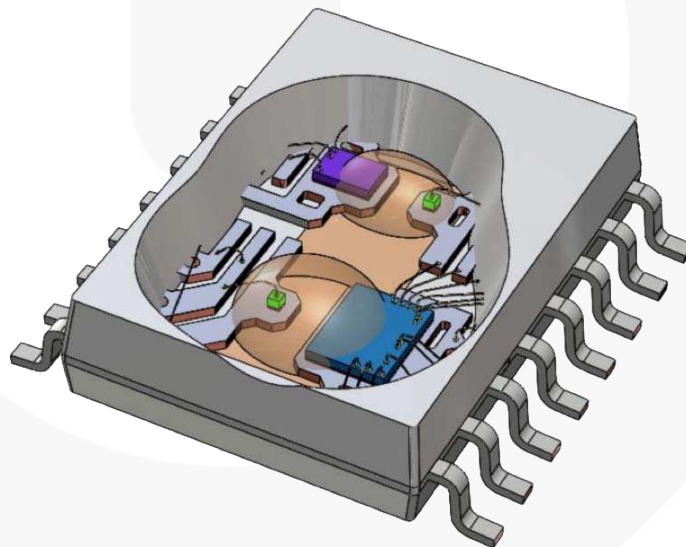

Figure 1. 3-Dimensional Illustration of the Internal Die Set of Fairchild's Optoplanar[®] Package Construction

1.1. Features and Benefits

- 2.5 A Output Current Driving Capability for Most Medium Power IGBTs
- High Noise Immunity Characterized by CMR: 35 kV/ μ s at $V_{cm} = 1500 V_{peak}$
- 1414 V_{peak} Working Insulation Voltage and 8000 V_{peak} Transient Isolation Voltage Rating
- Output Voltage Swing Rail-to-Rail: Low Power Dissipation
- Soft IGBT Turn-Off
- High Speed: 250 ns Propagation Delay
- 3.3 V / 5 V, CMOS/TTL-Compatible Inputs

1.2. Applications

- Motor Drives
- Industrial Inverters
- Solar Power Inverters
- Uninterruptible Power Supplies (UPS)
- Induction Heating
- Isolated IGBT Drive

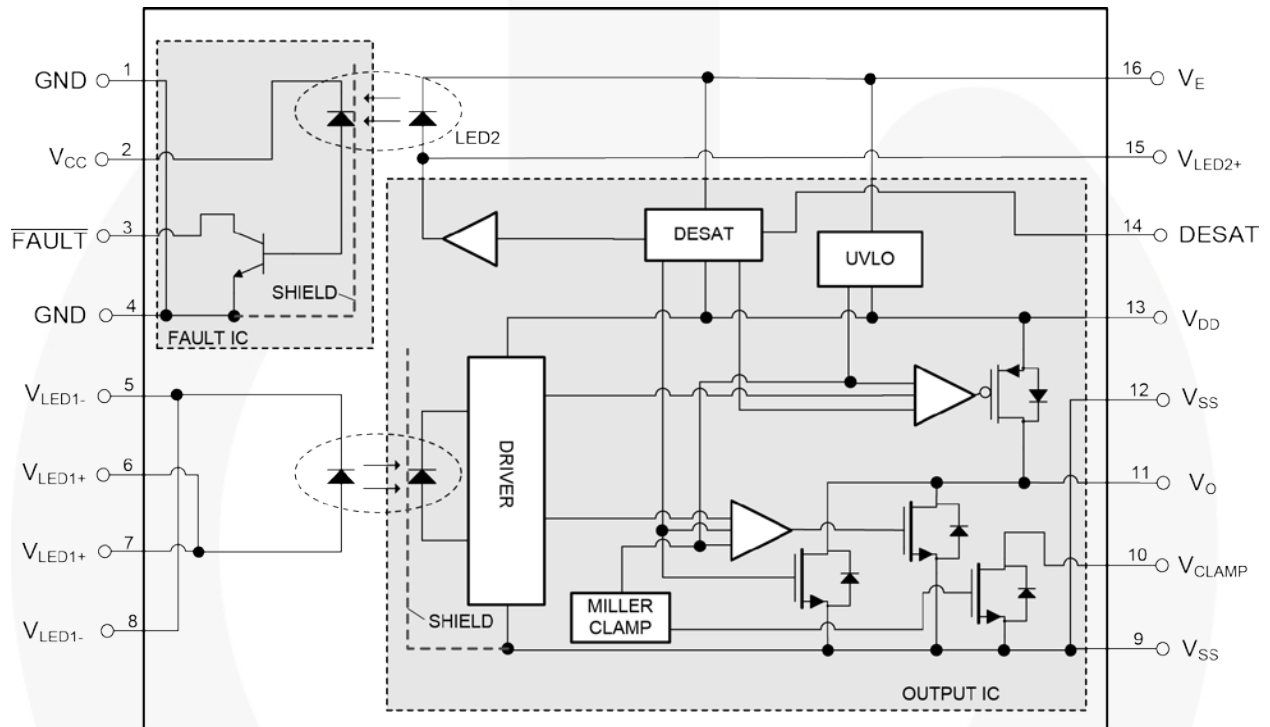

Figure 2. FOD8332 and FOD8333 Block Diagram

2. Operations

The application circuit and the timing diagram illustrate the functional use of the FOD833x between a micro-controller and a three-phase system, as well as the interaction of the internal and external signals.

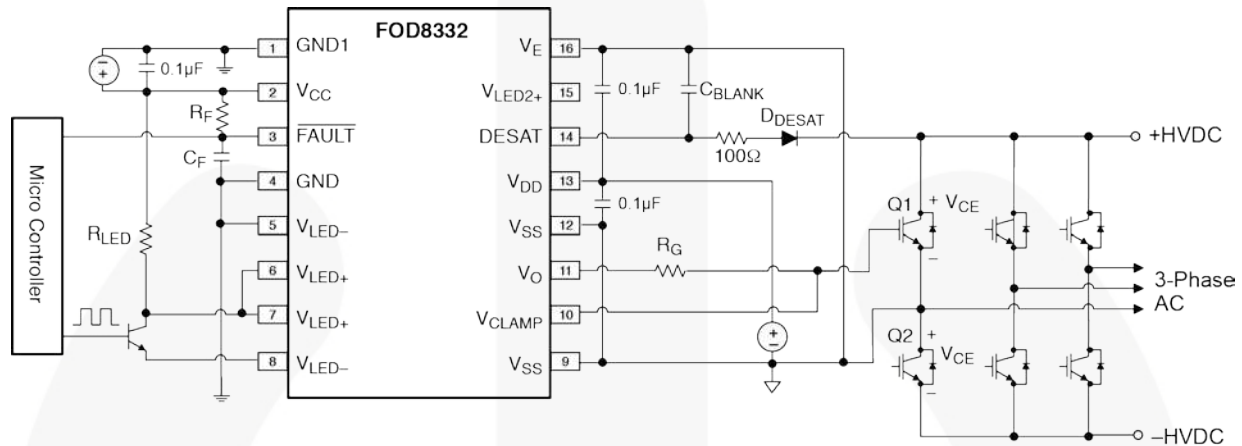

Figure 3. Typical Application Circuit

The internal gate driving circuitry of FOD833x can be used with either a single positive power supply, V_{DD} , or a dual positive and negative supply, V_{DD} and V_{SS} . The output driver stage, V_O , is made up of a pair of PMOS and NMOS transistors, which facilitates close to rail-to-rail output swing. This allows a tight control of gate voltage during on-state and short-circuit condition. Due to the low $R_{DS(ON)}$ of the MOSFETs, the power dissipation is reduced as compared to bipolar-type driver output stages. The absolute maximum rating of the output peak current, $I_{O(PEAK)}$, is 3 A.

FOD833x provides short-circuit protection by means of desaturation-detection circuits that monitor the collector-emitter voltage of the IGBT. When the DESAT voltage increases above the threshold voltage, a short-circuit condition is detected and the driver output stage executes a “soft” IGBT turn-off and is eventually driven low. The soft turn-off feature ensures the safe turn-off of the IGBT under fault conditions. This reduces the voltage spike on the collector of the IGBT. Without this, the IGBT would see a heavy spike on the collector, resulting in a permanent damage to the device when it is turned off immediately. The FAULT open-drain output is triggered active LOW to report a desaturation error to the micro-controller. The FAULT signal is reset when V_{LED1+} is pulled from LOW to HIGH for FOD8332 or automatically after $t_{DESAT(MUTE)}$ for FOD8333. The DESAT fault detector should be disabled for a short period (blanking time) before the IGBT turns on to allow the collector voltage to fall below the DESAT threshold. This blanking period protects against false trigger of the DESAT while the IGBT is turning on.

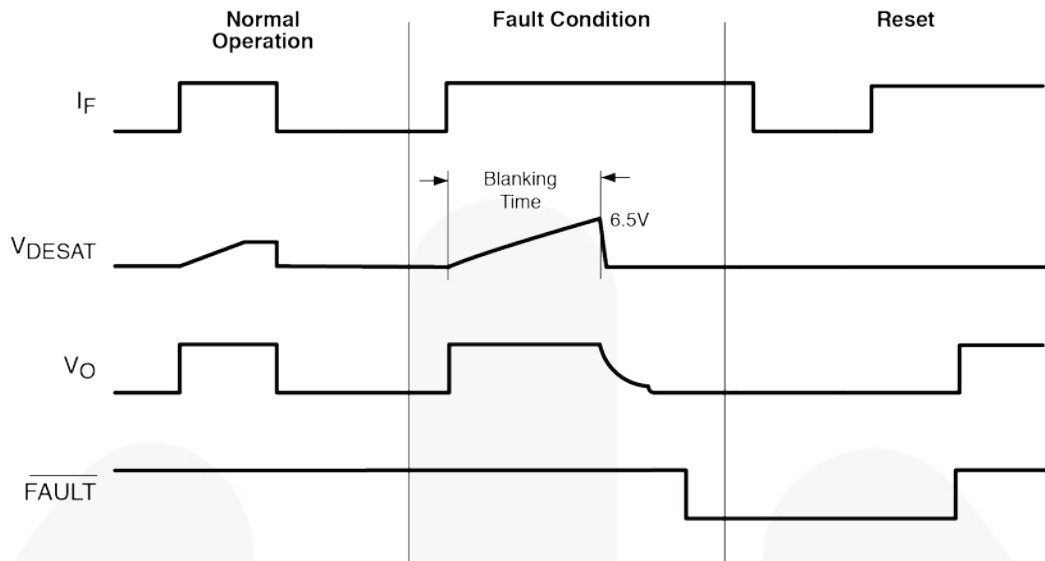

Figure 4. FOD8332 Timing Diagram

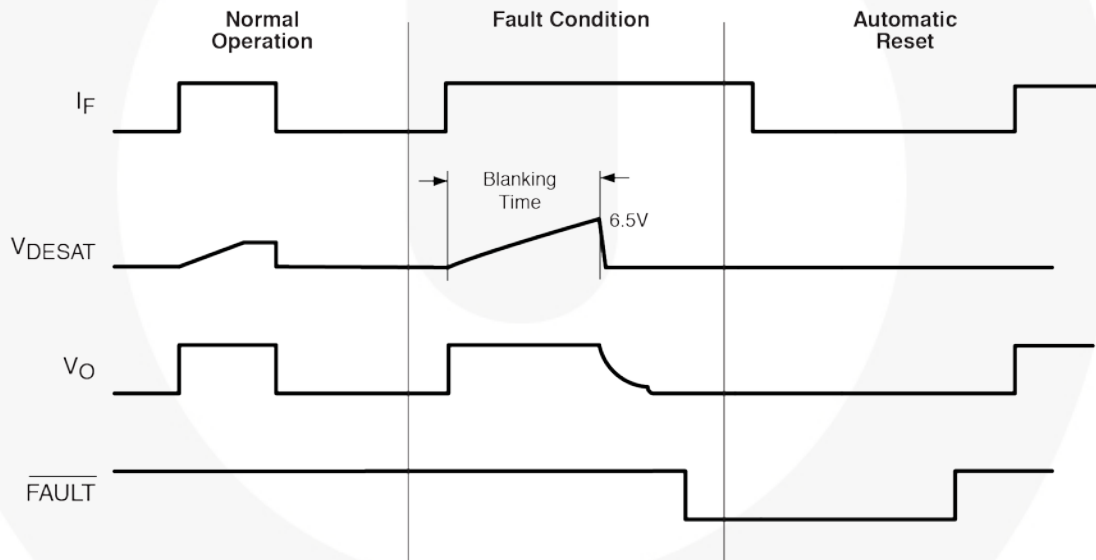

Figure 5. FOD8333 Timing Diagram

The FOD833x is also designed with an under-voltage detection circuit to prevent the application of insufficient gate voltage to the IGBT. This could be dangerous, as it would drive the IGBT out of saturation and into the linear operation where the losses are very high and the device is quickly overheated.

3. Circuit Schematic

The FEBFOD833x evaluation board with a booster circuit is designed for the evaluation of FOD833x timing sequence and AC test performance when driving an IGBT power module. It is recommended to be used in conjunction with the datasheet.

The FOD833x is designed to perform as a stand-alone, optically coupled, gate driver in most applications. If larger gate drive capability is needed for large IGBT modules or parallel operation, an output booster stage may be added to driver for optimum performance.

One possible implementation is by a discrete NPN/PNP totem-pole configuration. These booster transistors should be fast switching and have sufficient current gain to deliver the desired peak output current.

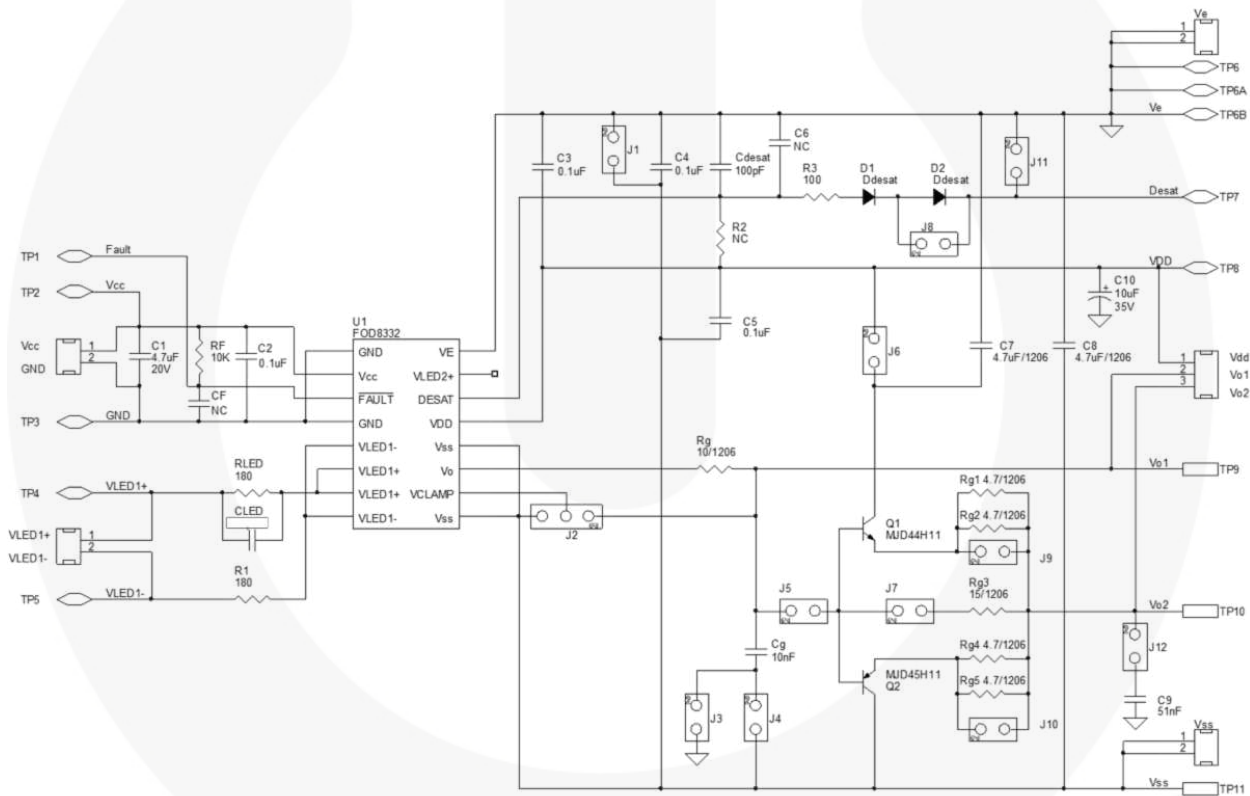

Figure 6. Circuit Schematic

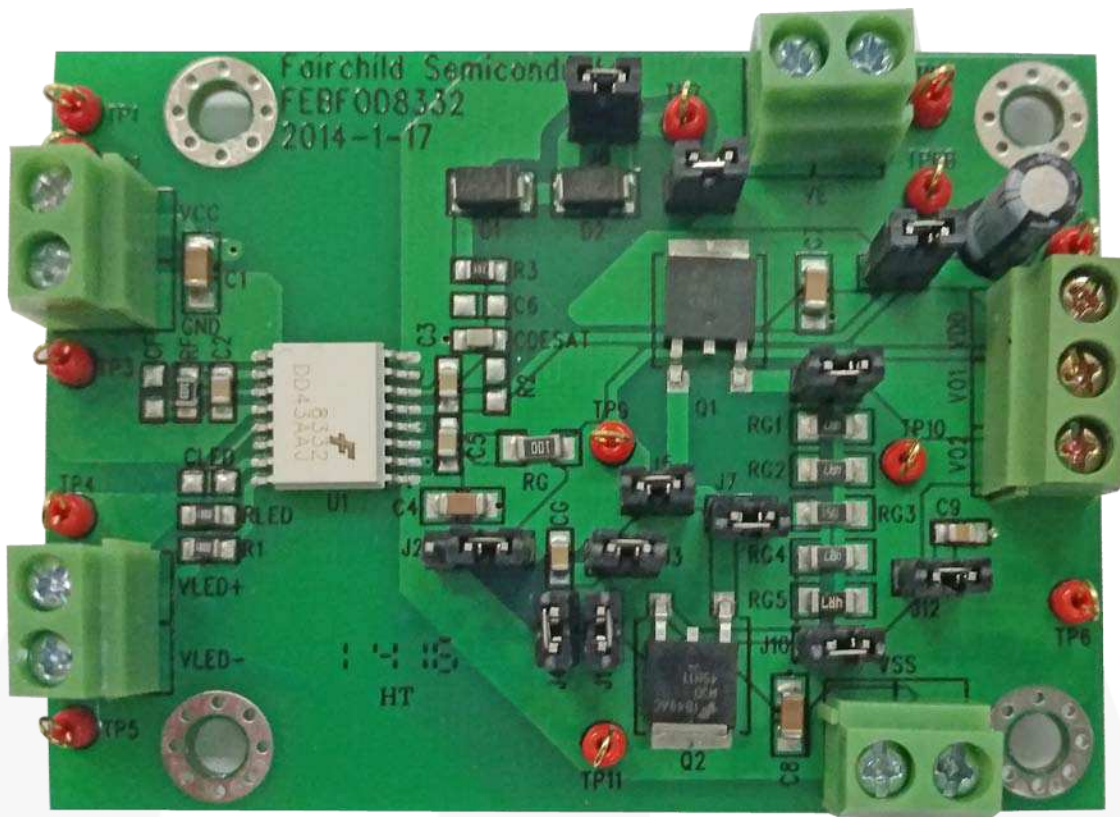

Figure 6. Photograph of the Board

This board consists of a FOD833x component, a non-inverting bipolar (NPN/PNP) totem-pole current buffer, two capacitor loads (10 nF / 51 nF), as well as connectors and test terminals for power supplies and input signals.

The FOD833x can be evaluated as a stand-alone gate driver driving a 10 nF capacitor load or FOD833x with the totem-pole current buffer driving a 51 nF capacitor load.

4. Setup and Operation

The setup requires three power supply sources: V_{CC} on one side of the isolation barrier, V_{DD} (positive supply), and V_{SS} (negative supply) on the other side of the isolation barrier.

The input signal is applied at the V_{LED1+} and the resulting output is used to drive either a 10 nF capacitor load (C_g) or a totem-pole current buffer, which in turn drives a bigger 51 nF capacitor load (C_9). Test points located at selected positions (as indicated in the schematics) allow the user to probe out the signals and measure the switching characteristics of the device.

5. Test Procedures and Conditions

This section describes the default setup of the FEBFOD833x evaluation board. Please refer to the schematic in Figure 6.

1. Connect the power supplies across the following connector:
 - Across V_{CC} and GND. Set the voltage to 5 V.
 - Across V_{DD} and V_E (GND of the power supply). Set the voltage to 15 V.
 - Across V_E and V_{SS} (GND of the power supply). Set the voltage to 5 V.

This power supply configuration enables V_O to swing from -5 V to 15 V.

2. Apply the following signal at V_{LED1+} : 10 kHz, square wave, 50% duty cycle, amplitude = 5 V.
3. Evaluation can be completed with the FOD833x as a standalone gate driver or together with the totem-pole current buffer. The jumper configurations are shown in Table 1 on the next page.
4. If soft turn-off evaluation is required, J11 must be left open, with no shorting jumper installed. This allows the DESAT pin to be charged above DESAT threshold voltage.
5. Scope shots of the signals are shown in the subsequent section, using the board in standalone set up and with the totem-pole current buffer.
6. Additional evaluation is accomplished by changing the jumper configuration. For example, the board can be configured to positive gate drive ($V_O > 0$ V), only requiring one power supply source at each side of the isolation barrier. The DESAT threshold voltage (seen at TP7) and the blanking time, can also be varied using jumper J8 and by soldering additional capacitor on the C6 pads.
7. The test points and their corresponding signals are listed in Table 2.

Table 1. **EVB Jumper Configurations**

Configuration	J1	J2	J3	J4 ⁽¹⁾	J5	J6	J7	J8	J9	J10	J11	J12	J13	J14	J15
V _O Swing = -5 V to 15 V; FOD833x Standalone		X	X								X				
V _O Swing = -5 V to 15 V; FOD833x and Totem-Pole		X	X		X	X	X				X				
V _O swing = -5 V to 15 V; FOD833x and Totem-Pole (for Soft Turn-off Evaluation)		X	X		X	X	X								
V _O swing = -5 V to 15 V; FOD833x Standalone (for Soft Turn-off Evaluation)		X	X												

Note:

1. X = Jumper short, blank = jumper open.

Table 2. **Test Points**

Test Points	Description
TP1	FAULT, Fault-Sense Output
TP2	V _{CC} , Positive Supply Voltage (3 V to 15 V for Fault-Sense Optocoupler)
TP3	GND, Ground for FAULT-Sense Optocoupler
TP4	V _{LED1+} , LED1 Anode
TP5	V _{LED1-} , LED1 Cathode; must be connected to ground.
TP6 /6A /6B	VE, Output Supply Voltage/IGBT Emitter
TP7	DESAT, Desaturation Voltage Input
TP8	V _{DD} , Positive Output Supply Voltage
TP9	V _O , Gate Drive Output Voltage
TP10	V _{O2} , Totem Pole Current Buffer Output Voltage
TP11	V _{SS} , Negative Output Supply Voltage

6. Scope Shots

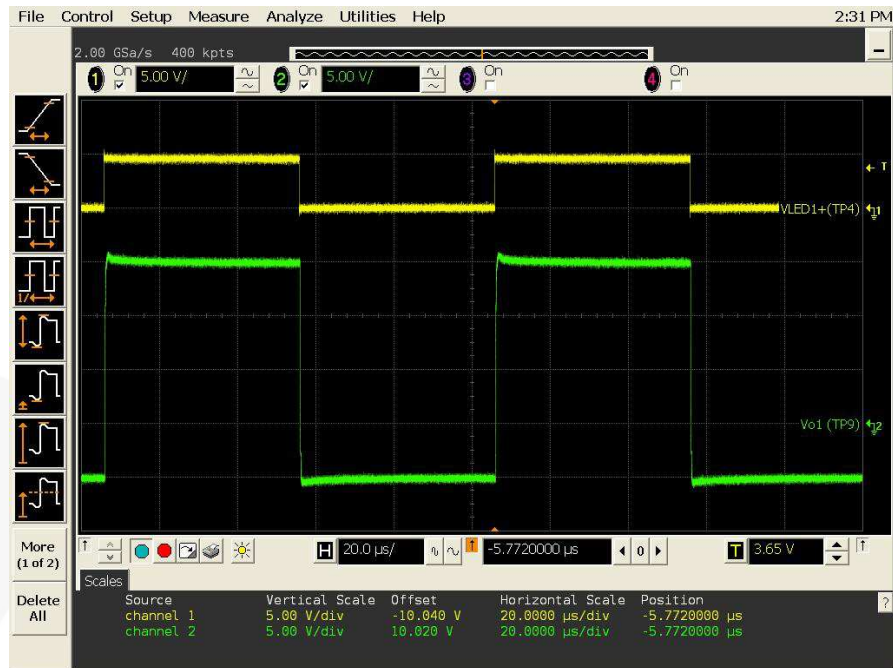

Figure 7. FOD833x without Totem-Pole Current Buffer - V_{LED1+} and V_{O1} Waveform



Figure 8. FOD833x without Totem-Pole Current Buffer - V_{LED1+} and V_{O1} Waveform During Soft Turn-Off

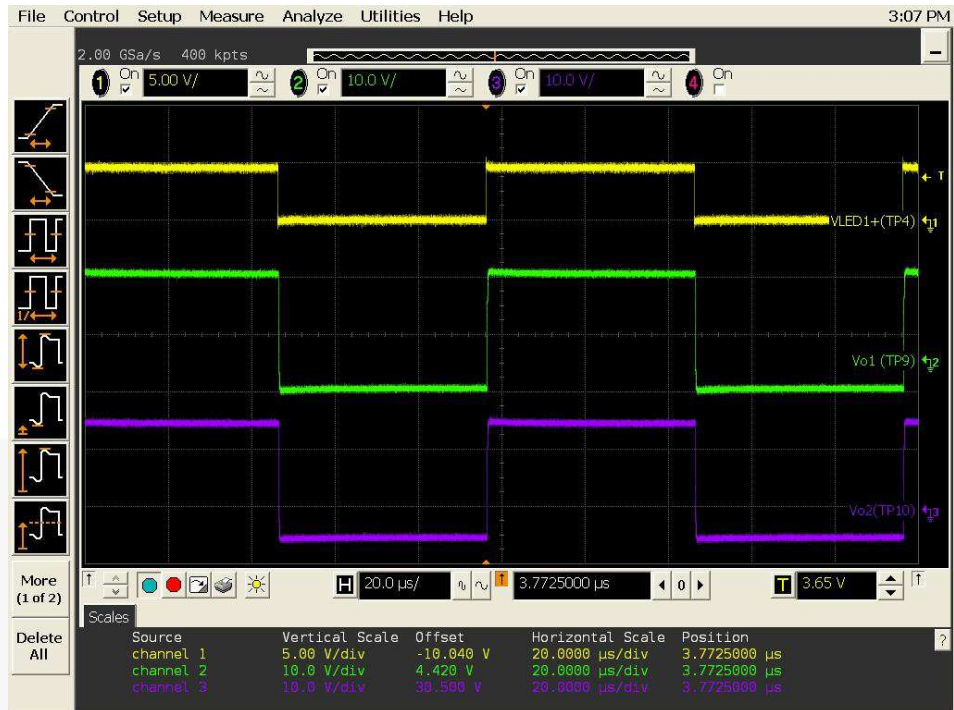

Figure 9. FOD833x with Totem-Pole Current Buffer - V_{LED1+} , V_{O1} and V_{O2} Waveform

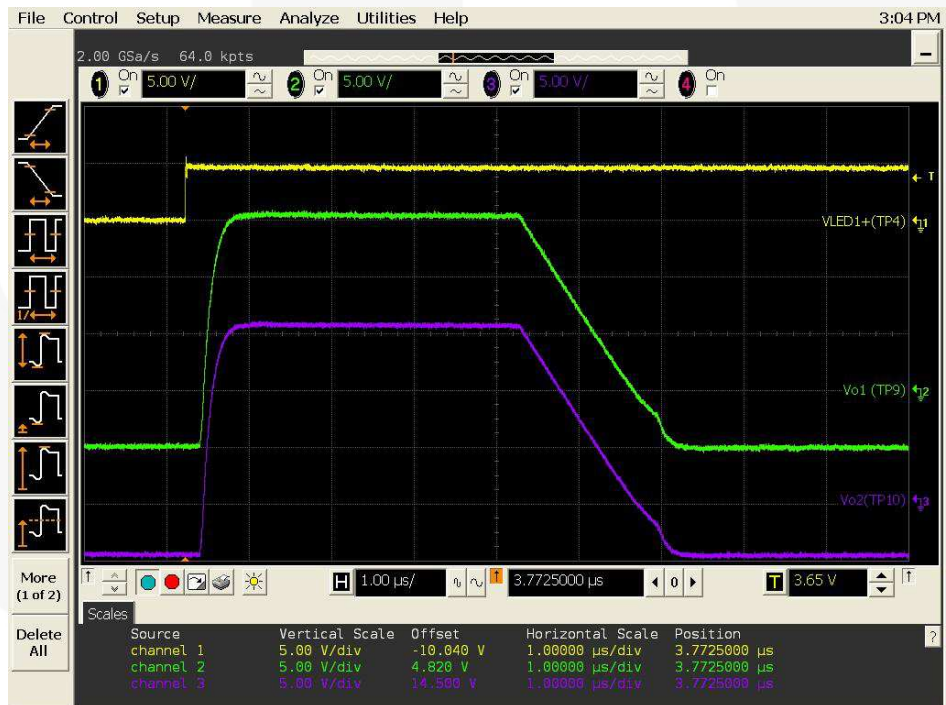

Figure 10. FOD833x with Totem-Pole Current Buffer - V_{LED1+} , V_{O1} and V_{O2} Waveform During Soft Turn-Off



7. Conclusion

The FEBFOD833x evaluation board allows the user to quickly evaluate the performance of the Fairchild FOD833x smart gate driver optocoupler.

Measurement results clearly demonstrate the AC performance and critical protection features of the product that are needed during IGBT fault conditions. With proper booster circuit design, the gate drive capability can be enhanced without affecting key features, such as desaturation detection and soft turn-off timings.

8. Revision History

Rev.	Date	Description
1.0.0	July 2014	Initial Release

WARNING AND DISCLAIMER

Replace components on the Evaluation Board only with those parts shown on the parts list (or Bill of Materials) in the Users' Guide. Contact an authorized Fairchild representative with any questions.

This board is intended to be used by certified professionals, in a lab environment, following proper safety procedures. Use at your own risk. The Evaluation board (or kit) is for demonstration purposes only and neither the Board nor this User's Guide constitute a sales contract or create any kind of warranty, whether express or implied, as to the applications or products involved. Fairchild warrants that its products meet Fairchild's published specifications, but does not guarantee that its products work in any specific application. Fairchild reserves the right to make changes without notice to any products described herein to improve reliability, function, or design. Either the applicable sales contract signed by Fairchild and Buyer or, if no contract exists, Fairchild's standard Terms and Conditions on the back of Fairchild invoices, govern the terms of sale of the products described herein.

DISCLAIMER

FAIRCHILD SEMICONDUCTOR RESERVES THE RIGHT TO MAKE CHANGES WITHOUT FURTHER NOTICE TO ANY PRODUCTS HEREIN TO IMPROVE RELIABILITY, FUNCTION, OR DESIGN. FAIRCHILD DOES NOT ASSUME ANY LIABILITY ARISING OUT OF THE APPLICATION OR USE OF ANY PRODUCT OR CIRCUIT DESCRIBED HEREIN; NEITHER DOES IT CONVEY ANY LICENSE UNDER ITS PATENT RIGHTS, NOR THE RIGHTS OF OTHERS.

LIFE SUPPORT POLICY

FAIRCHILD'S PRODUCTS ARE NOT AUTHORIZED FOR USE AS CRITICAL COMPONENTS IN LIFE SUPPORT DEVICES OR SYSTEMS WITHOUT THE EXPRESS WRITTEN APPROVAL OF THE PRESIDENT OF FAIRCHILD SEMICONDUCTOR CORPORATION.

As used herein:

1. Life support devices or systems are devices or systems which, (a) are intended for surgical implant into the body, or (b) support or sustain life, or (c) whose failure to perform when properly used in accordance with instructions for use provided in the labeling, can be reasonably expected to result in significant injury to the user.
2. A critical component is any component of a life support device or system whose failure to perform can be reasonably expected to cause the failure of the life support device or system, or to affect its safety or effectiveness.

ANTI-COUNTERFEITING POLICY

Fairchild Semiconductor Corporation's Anti-Counterfeiting Policy. Fairchild's Anti-Counterfeiting Policy is also stated on our external website, www.fairchildsemi.com, under Sales Support.

Counterfeiting of semiconductor parts is a growing problem in the industry. All manufacturers of semiconductor products are experiencing counterfeiting of their parts. Customers who inadvertently purchase counterfeit parts experience many problems such as loss of brand reputation, substandard performance, failed applications, and increased cost of production and manufacturing delays. Fairchild is taking strong measures to protect ourselves and our customers from the proliferation of counterfeit parts. Fairchild strongly encourages customers to purchase Fairchild parts either directly from Fairchild or from Authorized Fairchild Distributors who are listed by country on our web page cited above. Products customers buy either from Fairchild directly or from Authorized Fairchild Distributors are genuine parts, have full traceability, meet Fairchild's quality standards for handling and storage and provide access to Fairchild's full range of up-to-date technical and product information. Fairchild and our Authorized Distributors will stand behind all warranties and will appropriately address any warranty issues that may arise. Fairchild will not provide any warranty coverage or other assistance for parts bought from Unauthorized Sources. Fairchild is committed to combat this global problem and encourage our customers to do their part in stopping this practice by buying direct or from authorized distributors.

EXPORT COMPLIANCE STATEMENT

These commodities, technology, or software were exported from the United States in accordance with the Export Administration Regulations for the ultimate destination listed on the commercial invoice. Diversion contrary to U.S. law is prohibited.

U.S. origin products and products made with U.S. origin technology are subject to U.S. Re-export laws. In the event of re-export, the user will be responsible to ensure the appropriate U.S. export regulations are followed.