



Chipsmall Limited consists of a professional team with an average of over 10 year of expertise in the distribution of electronic components. Based in Hongkong, we have already established firm and mutual-benefit business relationships with customers from,Europe,America and south Asia,supplying obsolete and hard-to-find components to meet their specific needs.

With the principle of “Quality Parts,Customers Priority,Honest Operation,and Considerate Service”,our business mainly focus on the distribution of electronic components. Line cards we deal with include Microchip,ALPS,ROHM,Xilinx,Pulse,ON,Everlight and Freescale. Main products comprise IC,Modules,Potentiometer,IC Socket,Relay,Connector.Our parts cover such applications as commercial,industrial, and automotives areas.

We are looking forward to setting up business relationship with you and hope to provide you with the best service and solution. Let us make a better world for our industry!



Contact us

Tel: +86-755-8981 8866 Fax: +86-755-8427 6832

Email & Skype: info@chipsmall.com Web: www.chipsmall.com

Address: A1208, Overseas Decoration Building, #122 Zhenhua RD., Futian, Shenzhen, China





User Guide for
FEBFSEZ1317WA_CH310v3
Evaluation Board

Primary-Side-Regulation PWM Controller
FSEZ1317WAMY
5.0V/0.7A Mobile Phone Battery Charger

Featured Fairchild Product:
FSEZ1317WA

*Direct questions or comments
about this Evaluation Board to:
“Worldwide Direct Support”*

Fairchild Semiconductor.com

Table of Contents

1. Introduction.....	3
2. General Specifications	3
3. Functional Test Report.....	4
3.1. Input Current.....	4
3.2. Input Power at No-Load Condition.....	5
3.3. Line Regulation and Load Regulation	7
3.4. Efficiency	7
3.5. Output Ripple and Noise.....	8
3.6. Step Response	10
3.7. Over-Power Protection.....	11
3.8. Hold-up Time.....	11
3.9. Measured Waveforms	12
3.10. Short-Circuit Protection	13
3.11. Brownout Test.....	14
3.12. V _{DD} Voltage Level	14
3.13. Voltage Stress on MOSFET & Rectifiers.....	18
3.14. Constant Voltage (CV) and Constant Current (CC) Curves.....	20
3.15. EMI Test (Output with 1.8M Cable Wire).....	21
3.16. Surge test.....	23
3.17. ESD Test	23
4. Photographs.....	24
5. Circuit Schematic.....	25
6. PCB Layout.....	26
7. 76-B070063-00 FSEZ1317WA Evaluation Board BOM.....	27
8. Specification Approval	28
9. Revision History	32

This user guide supports the evaluation board for the FSEZ1317WA. It should be used in conjunction with the datasheet as well as Fairchild’s application notes and technical support team. Please visit Fairchild’s website at www.fairchildsemi.com. This kit supersedes the FEBFSEZ1317A_CH310v3. The revised kit incorporates the next generation FSEZ1317WA, which implements a new frequency hopping method.

1. Introduction

This document describes a 3.5W power supply using an FSEZ1317WAMY device. This power supply is targeted for mobile phone battery chargers for a 30mW solution with high efficiency.

The controller used on the board is Fairchild Semiconductor’s FSEZ1317WAMY. This third-generation Primary-Side-Regulation (PSR) PWM controller with integrated MOSFET and improved EMI performance provides several features to enhance the performance of low-power flyback converters. The proprietary TRUECURRENT® technology enables precise Constant Current (CC) regulation and simplified circuit design for battery-charger applications. The result is a lower-cost, smaller, and lighter charger compared to conventional designs or a linear transformer. To minimize standby power consumption (30mW at 265V_{AC}), a proprietary Green Mode provides off-time modulation to linearly decrease PWM frequency under light-load conditions. Green Mode assists the power supply in meeting power conservation requirements. By using the FSEZ1317WA, a charger can be implemented with few external components and minimized cost. A typical output CV/CC (Constant Voltage / Constant Current) characteristic envelope is shown in Figure 23 and Figure 24.

2. General Specifications

Specification	Min.	Max.	Units
Input			
Voltage	90	264	V _{AC}
Frequency	47	63	Hz
Output			
Output Voltage	4.75	5.25	V
Output Current	0	0.7	A
Total Output Power			
Full-Load Output Power	0	3.5	W

Note:

1. All results tested with output DC cable, AWG 26, 1.8M.

3. Functional Test Report

Test Model	FEBFSEZ1317WA_CH310v3
Test Date	July 27, 2012
Test Temperature	Ambient
Test Equipment	AC Source: 6800 Series AC POWER SOURCE
	Electronic Load: Chroma 63030
	Power Meter: WT210
	Oscilloscope: TDS3014B
Test Items	<ol style="list-style-type: none"> 1. Input current 2. Input power at no-load condition 3. Startup time 4. DC output rising time 5. Line regulation and load regulation 6. Efficiency 7. Output ripple and noise 8. Step response 9. Over-current protection 10. Hold-up time 11. Short-circuit protection 12. Brownout test 13. V_{DD} voltage level 14. Voltage stress on MOSFET and rectifier 15. Constant voltage and constant current curve 16. EMI test 17. Surge Test 18. ESD test

3.1. Input Current

3.1.1. Test Condition

Measure the AC input current at maximum load.

3.1.2. Test Result

Input Voltage	Input Current
90V / 60Hz	96.73mA
264V / 50Hz	49.14mA

3.2. Input Power at No-Load Condition

3.2.1. Test Condition

Measure the input power and output voltage at no-load condition.

3.2.2. Test Result

Input Voltage	Input Wattage (mW)	Output Voltage (V)
90V / 60Hz	21.84	5.055
115V / 60Hz	22.79	5.056
230V / 50Hz	25.8	5.075
264V / 50Hz	28.1	5.085

3.2.3. Measured Waveforms

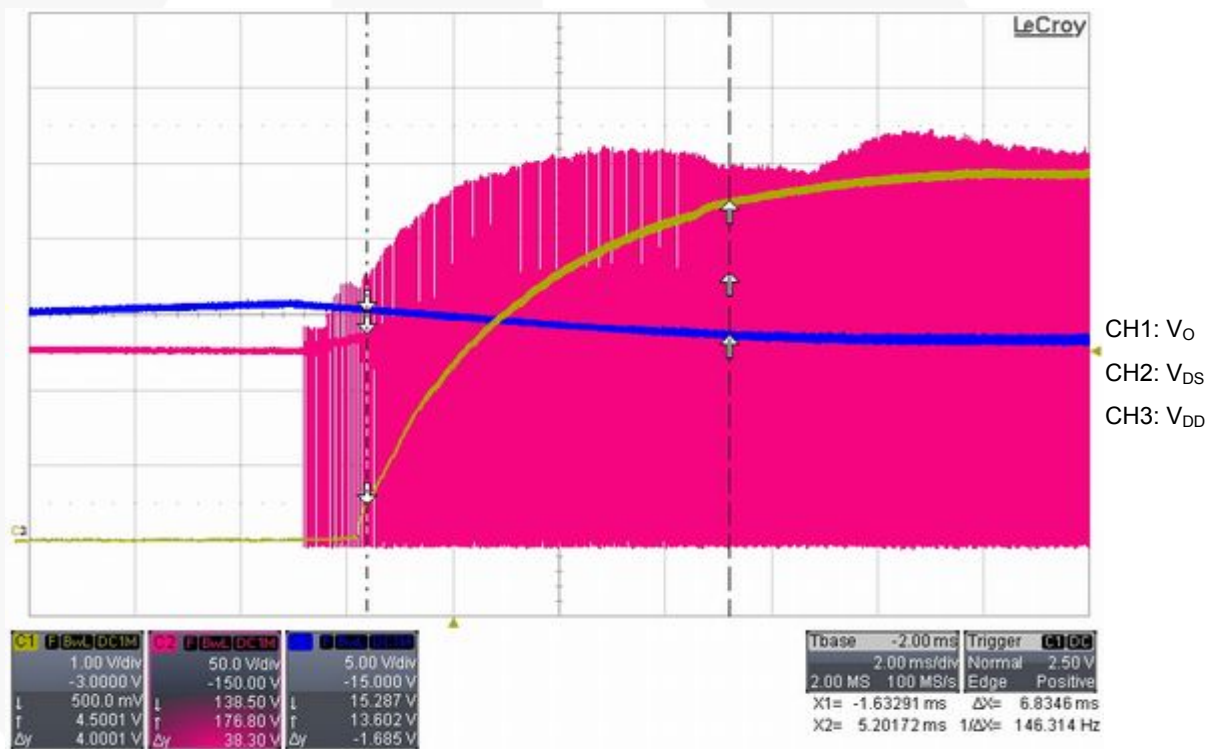

Figure 1. 90V/60Hz at Maximum Load

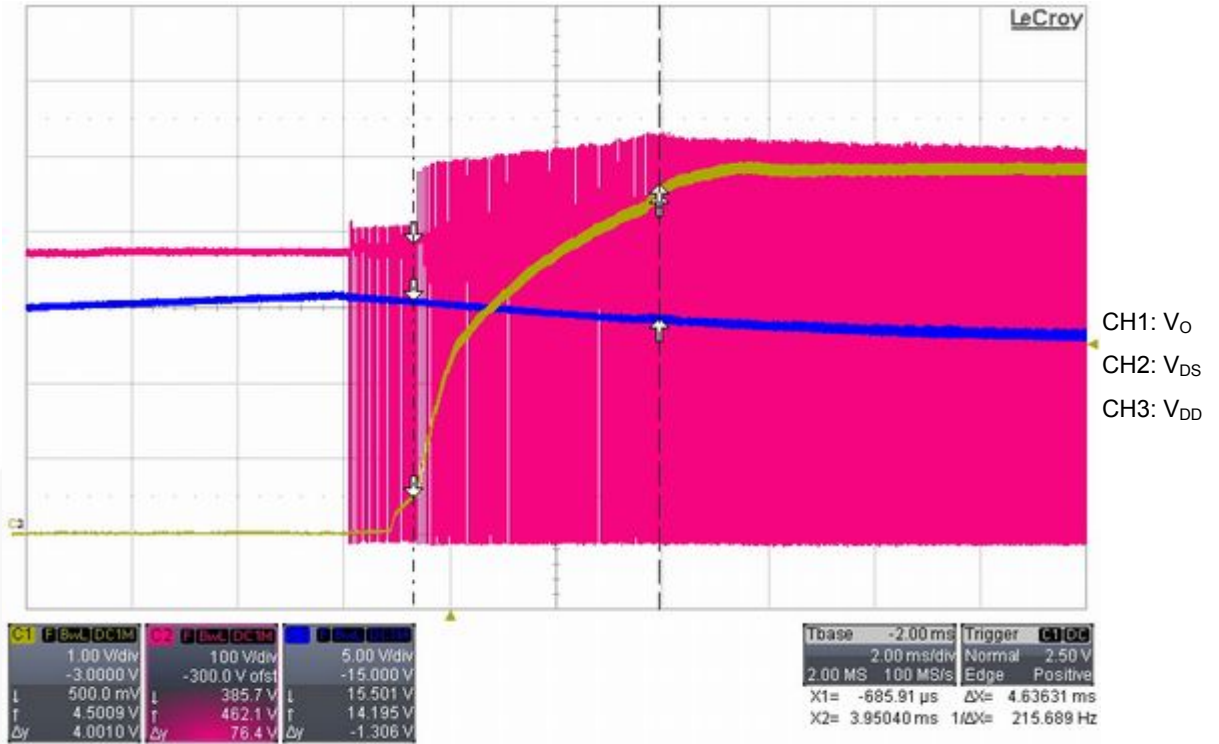

Figure 2. 264V/50Hz at Maximum Load

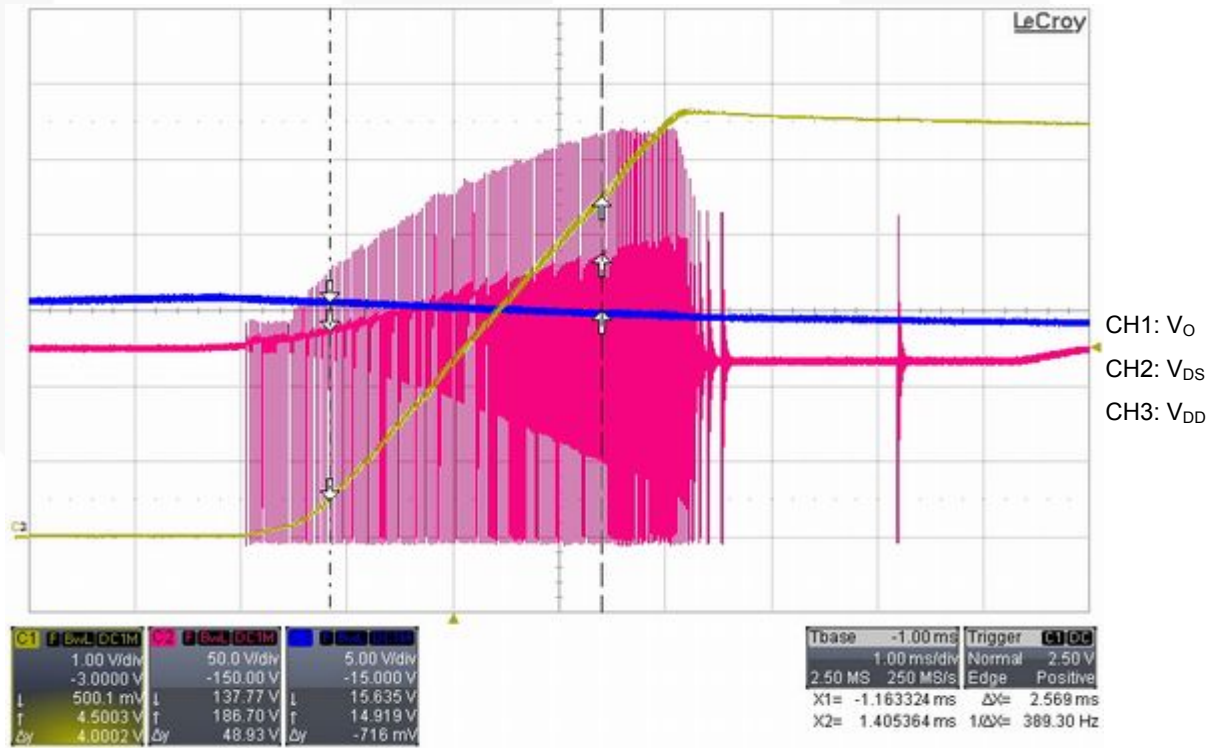

Figure 3. 90V/60Hz at No Load

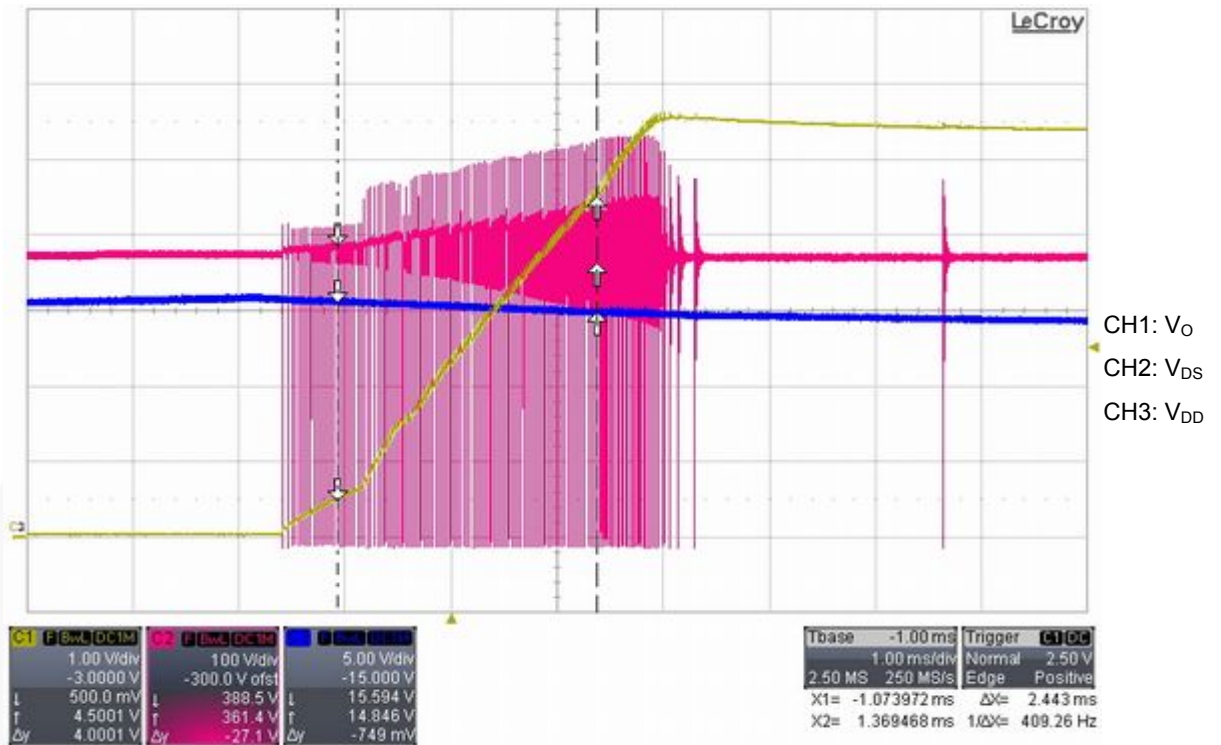

Figure 4. 264V/50Hz at No Load

3.3. Line Regulation and Load Regulation

3.3.1. Test Condition

Measure line regulation and load regulation according to below table of test results.

3.3.2. Test Result

Input Voltage	Output Voltage at Maximum Load (V)	Output Voltage at Minimum Load (V)	Load Regulation (%)	Specification
90V / 60Hz	5.032	5.055	0.23	±5%
115V / 60Hz	5.035	5.056	0.21	
230V / 50Hz	5.036	5.075	0.39	
264V / 50Hz	5.038	5.085	0.47	
Line Regulation(%)	0.06	0.3		

3.4. Efficiency

3.4.1. Test Condition

Measure input power and output power at maximum load.

3.4.2. Test Result

Input Voltage	Input Wattage (W)	Output Wattage (W)	Efficiency (%)
90V / 60Hz	5.061	3.518	69.50
115V / 60Hz	4.981	3.526	70.79
230V / 50Hz	4.979	3.537	71.03
264V / 50Hz	5.013	3.537	70.55

3.4.3. Test Result

Input Voltage	Efficiency(%)				
	25% Load	50% Load	75% Load	100% Load	Avg.
115V / 60Hz	71.24	72.58	72.02	70.79	71.66
230V / 50Hz	68.94	71.50	71.73	71.03	70.80

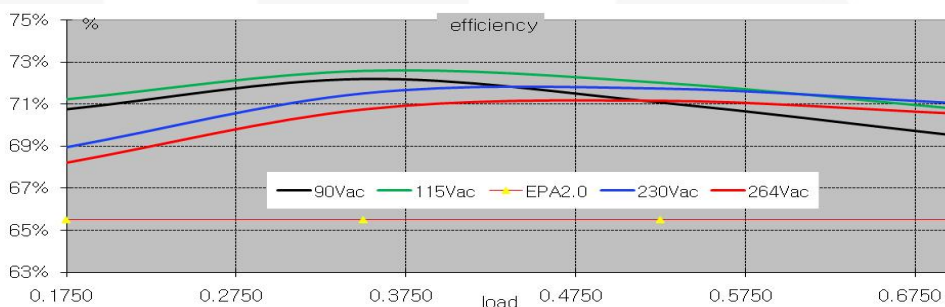

Figure 5. Efficiency

3.5. Output Ripple and Noise

3.5.1. Test Condition

Ripple and noise are measured by using a 20MHz bandwidth-limited oscilloscope with a 10 μ F capacitor paralleled with a high-frequency 0.1 μ F capacitor across each output.

3.5.2. Test Result

Input Voltage	Maximum Load (mV)	Minimum Load (mV)	Specification
90V / 60Hz	136	40	200mV
115V / 60Hz	134	32	
230V / 50Hz	146	35	
264V / 50Hz	154	40	

3.5.3. Measured Waveforms

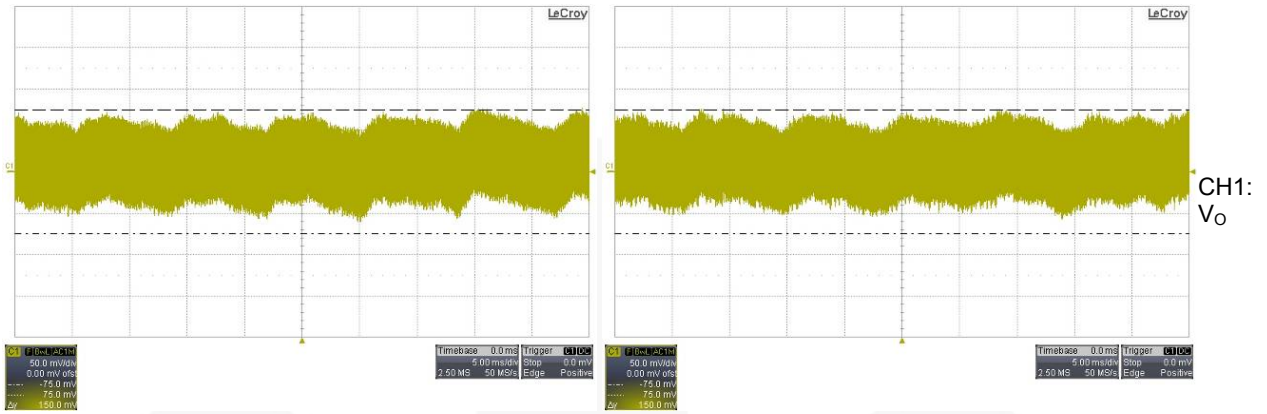

Figure 6. 90V/60Hz and 115V/60Hz at Maximum Load

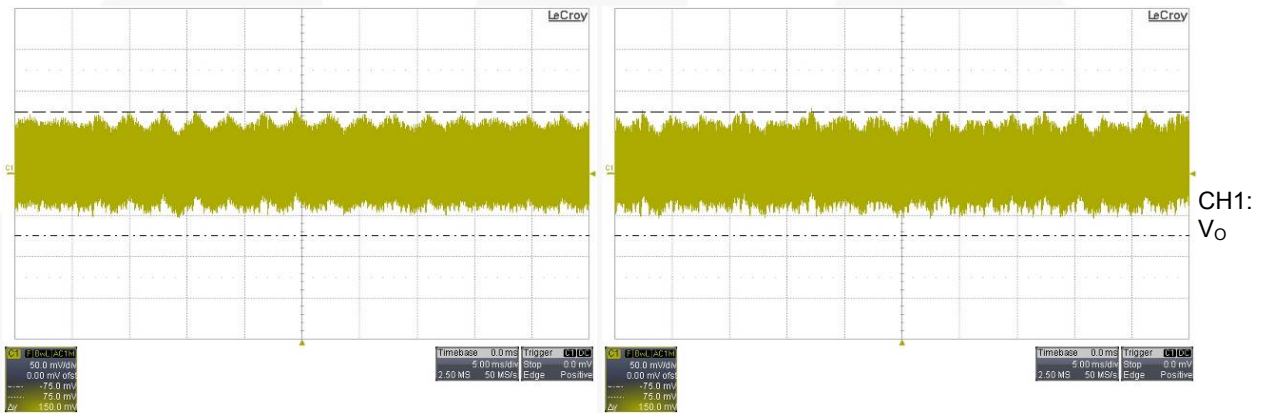

Figure 7. 230V/50Hz and 264V/50Hz at Maximum Load

3.6. Step Response

3.6.1. Test Condition

Dynamic loading (20%~80% of the full load, 5ms duty cycle, 2.5 A/ μ s rise/fall time).

3.6.2. Test Result

Input Voltage	Overshoot (mV)	Undershoot (mV)
115V / 60Hz	300	310
230V / 50Hz	320	320

3.6.3. Measured Waveforms

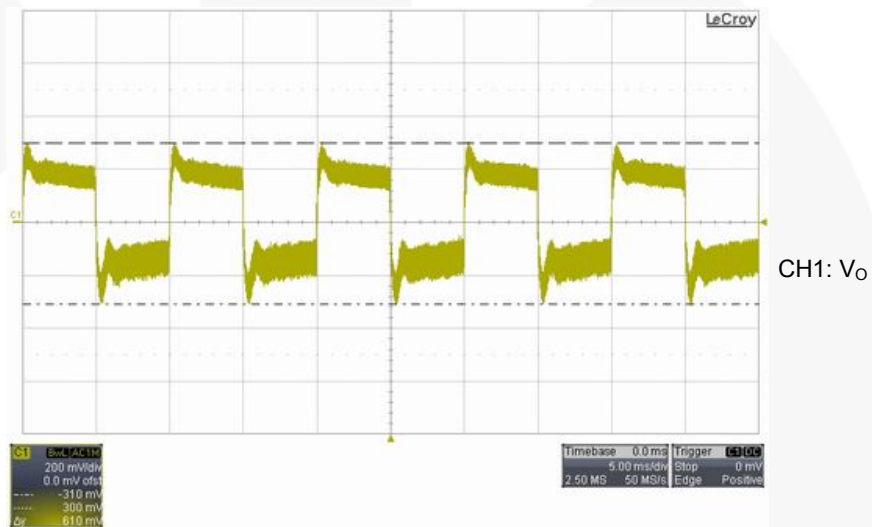

Figure 8. 115V/60Hz at Maximum Load

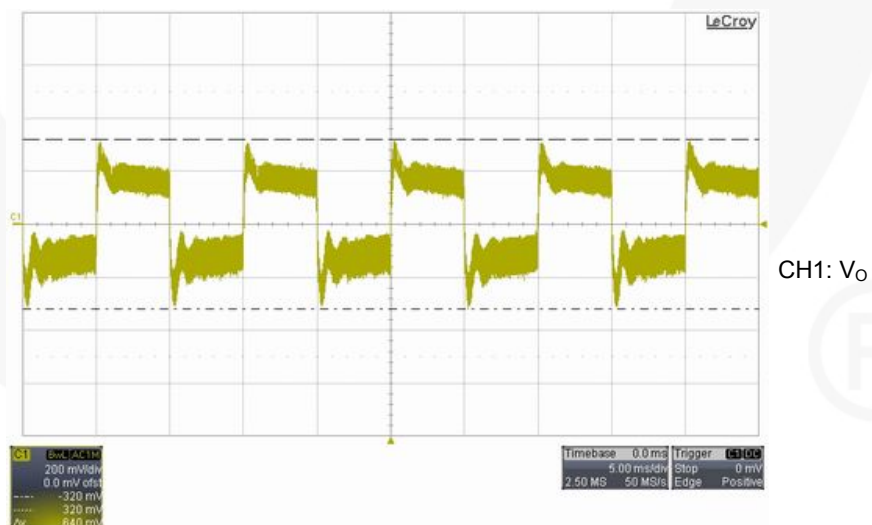

Figure 9. 230V/50Hz at Maximum Load

3.7. Over-Power Protection

3.7.1. Test Condition

Increase output loading gradually. Measure the output maximum power.

3.7.2. Test Result

Input Voltage	Output Power(W)
90V / 60Hz	3.80
115V / 60Hz	3.83
230V / 50Hz	3.90
264V / 50Hz	3.93

3.8. Hold-up Time

3.8.1. Test Condition

Set output at maximum load. Measure the time interval between AC off and output voltage falling to lower limit of rated value. The AC waveform should be off at zero degrees.

3.8.2. Test Result

Input Voltage	Hold-up Time (ms)
90V / 60Hz	11.32
115V / 60Hz	20.71
230V / 50Hz	102.00
264V / 50Hz	136.50

3.9. Measured Waveforms

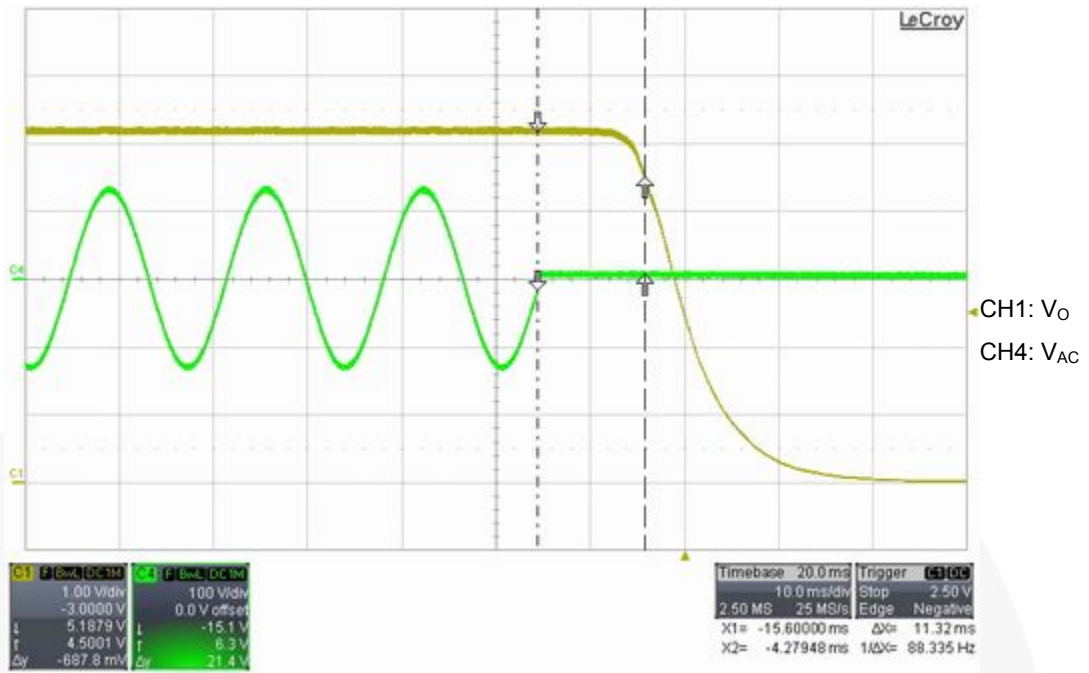

Figure 10. 90V/60Hz at Maximum Load

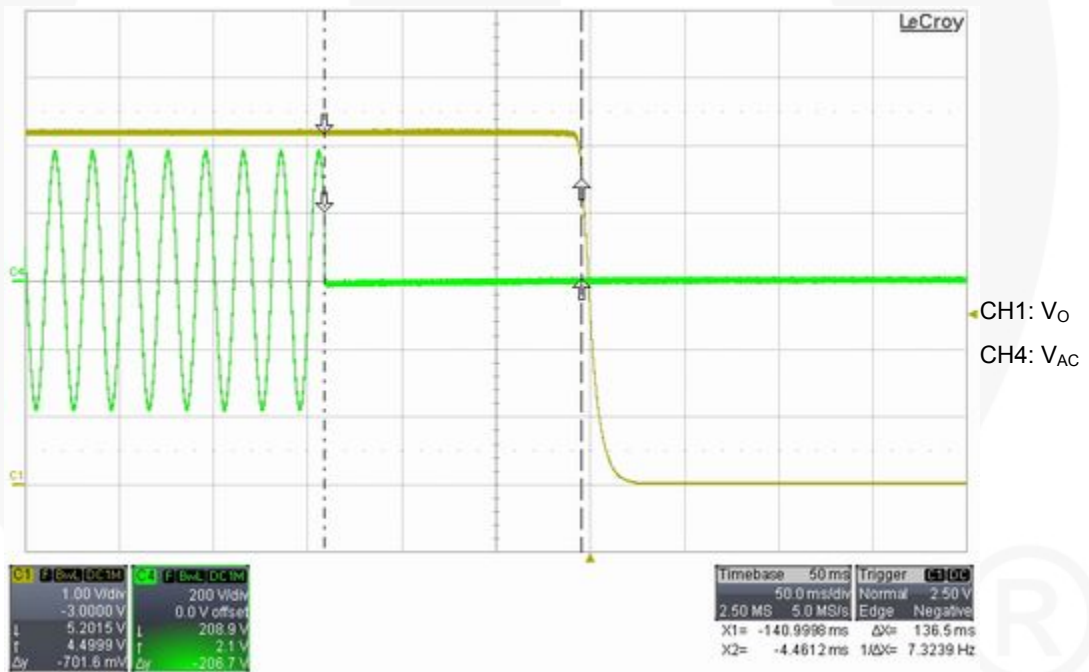

Figure 11. 264V/50Hz at Maximum Load

3.10. Short-Circuit Protection

3.10.1. Test Condition

Short the output of the power supply. The power supply should enter “Hiccup” Mode protection with less than 2W input voltage.

3.10.2. Test Result

Input Voltage	Input Wattage at Maximum Load (W)	Input Wattage at Minimum Load (W)
90V / 60Hz	0.2770	0.2825
264V / 50Hz	0.8230	0.8460

3.10.3. Measured Waveforms

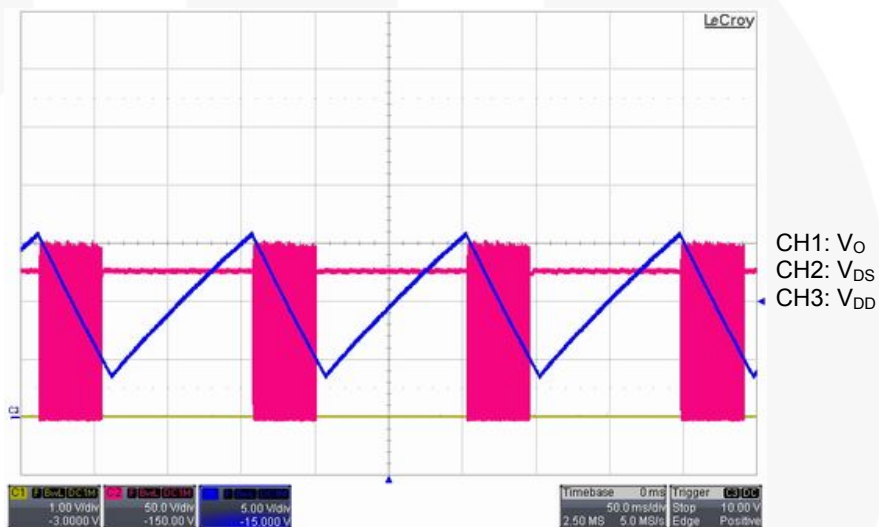

Figure 12. 90V/60Hz at Maximum Load

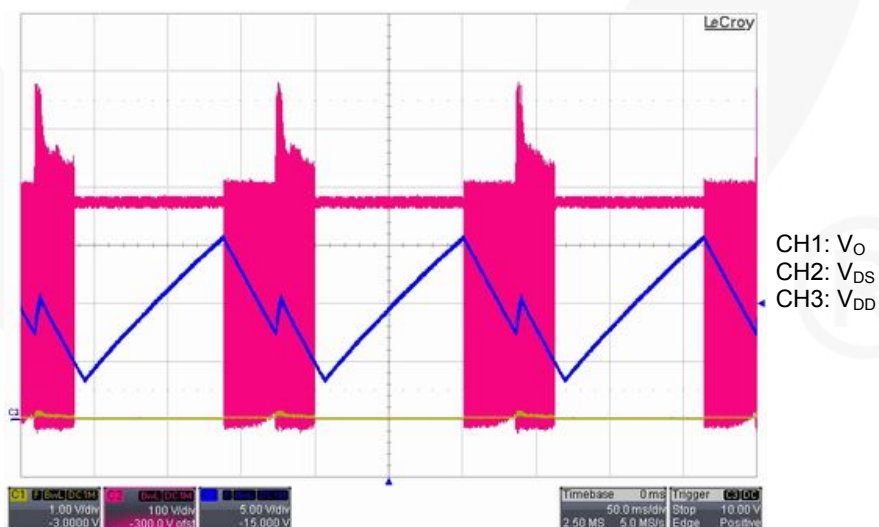

Figure 13. 264V/50Hz at Maximum Load

3.11. Brownout Test

3.11.1. Test Condition

Set output at maximum loading. Decrease input voltage with 5V_{AC} step. Record input wattage and output voltage. After the output is off, increase the AC voltage gradually and record the recovery voltage.

3.11.2. Test Result

Input Voltage	Input Wattage (W)	Output Voltage(V)
90V / 60Hz	5.136	5.186
85V / 60Hz	5.169	5.186
80V / 60Hz	5.198	5.182
75V / 60Hz	5.236	5.176
70V / 60Hz	5.281	5.162
Recovery Input Voltage		
70V / 60Hz	5.280	5.162

3.12. V_{DD} Voltage Level

3.12.1. Test Result

	Min. Load (V)	Max. Load (V)	Near OPP (V)	Output Short Circuit (V)
90V / 60Hz	7.7	13.6	13.7	16.0
264V / 50Hz	7.4	13.5	13.5	15.8

3.12.2. Measured Waveforms

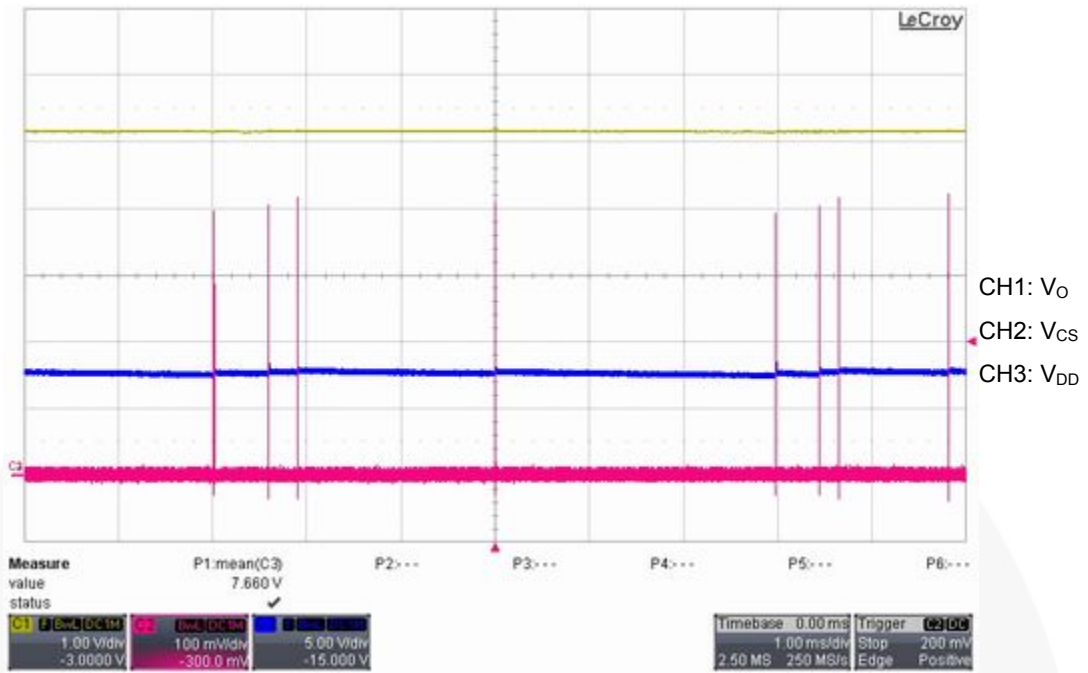

Figure 14. 90V/60Hz at No Load

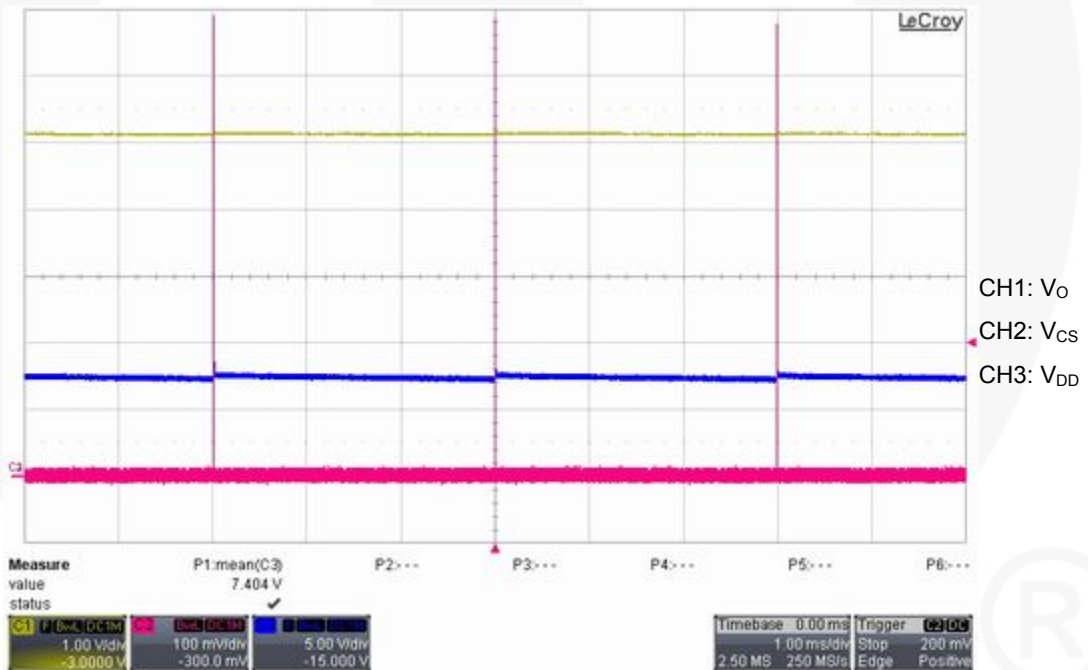

Figure 15. 264V/50Hz at No Load

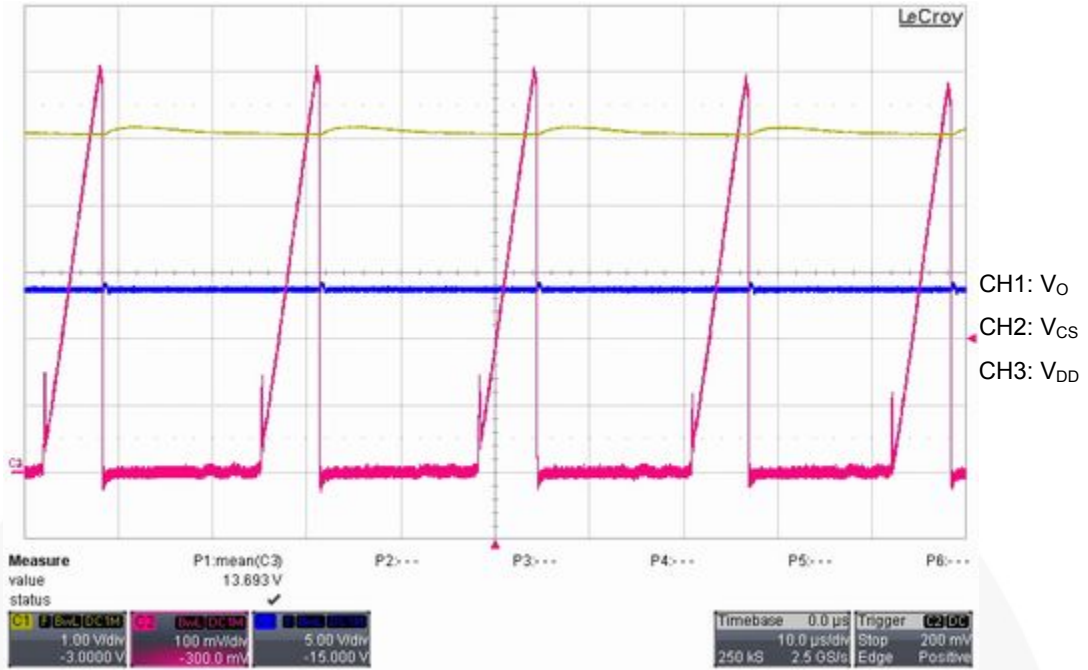

Figure 16. 90V/60Hz at Over-Power Protection

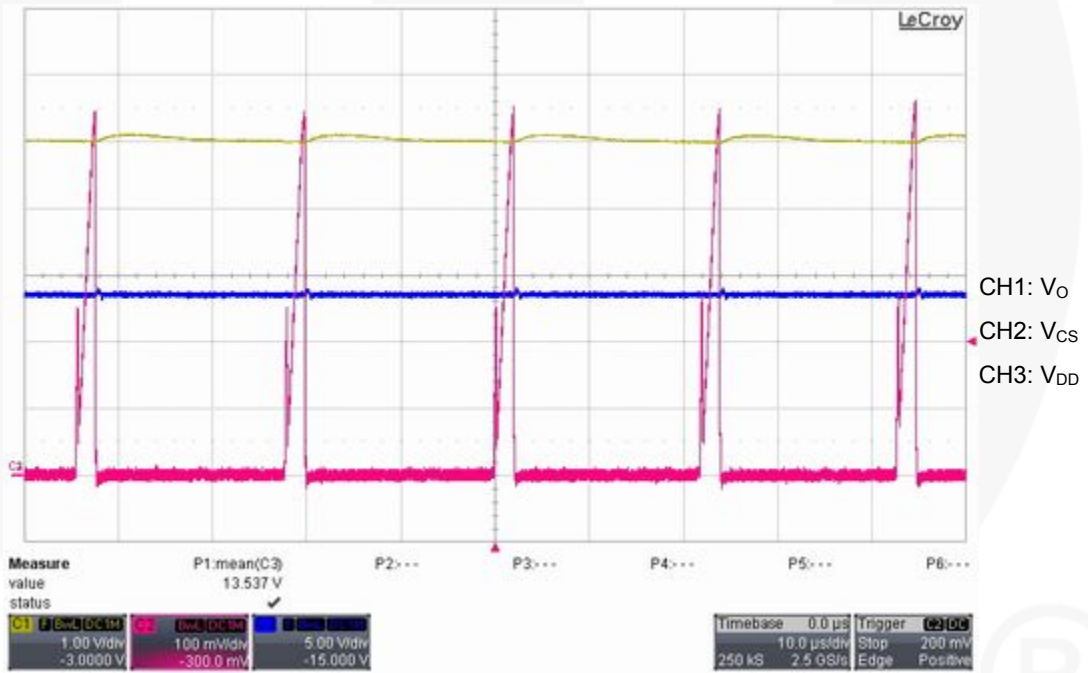

Figure 17. 264V/50Hz at Over-Power Protection

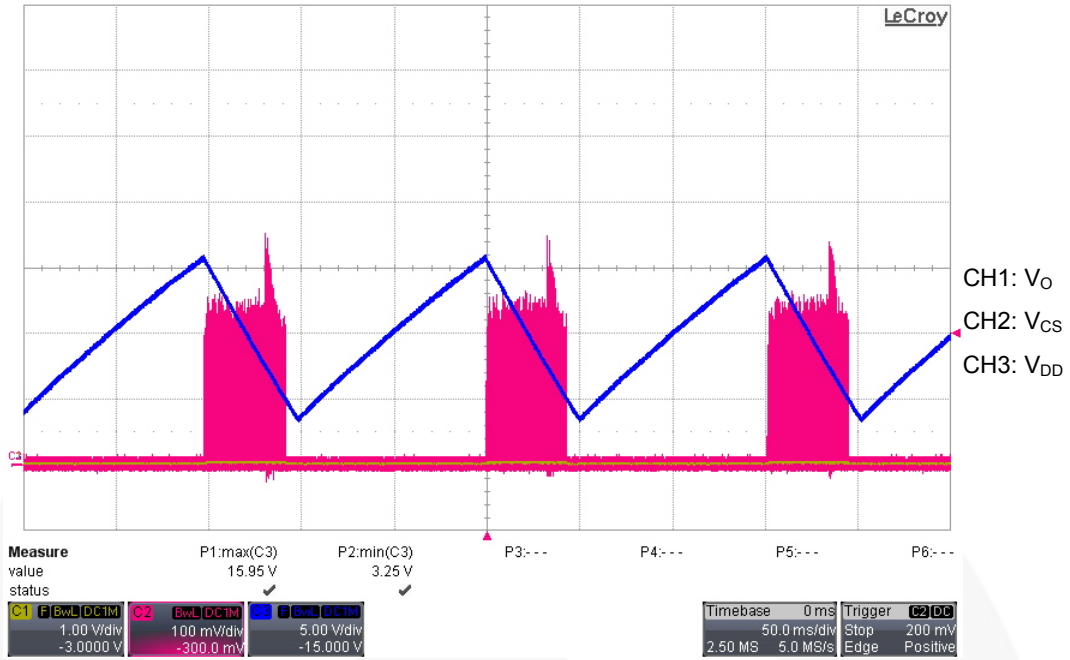

Figure 18. 90V/60Hz at Output Short

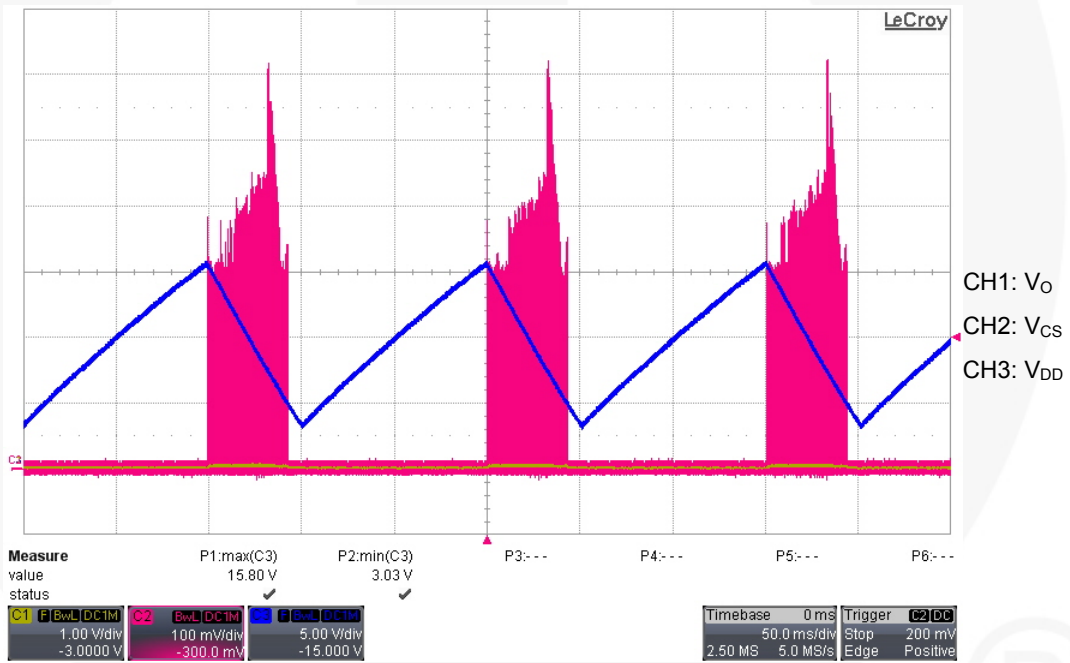

Figure 19. 264V/50Hz at Output Short

3.13. Voltage Stress on MOSFET & Rectifiers

3.13.1. Test Condition

Measure the voltage stress on MOSFET and secondary rectifiers under conditions specified below.

3.13.2. Test Result

	Stress on MOSFET	Rating	Stress on Rectifier	Rating
90V / 60Hz, Max. Load	287	700V	16.0	40V
90V / 60Hz, Max. Load, Startup	284		16.0	
90V / 60Hz, Max. Load, Output Short	182		11.0	
264V / 50Hz, Max. Load	549		36.8	
264V / 50Hz, Max. Load, Startup	542		36.2	
264V / 50Hz, Max. Load, Output Short	606		32.3	
264V / 50Hz, Max. Load Turns Off	549		36.8	

3.13.3. Measured Waveforms

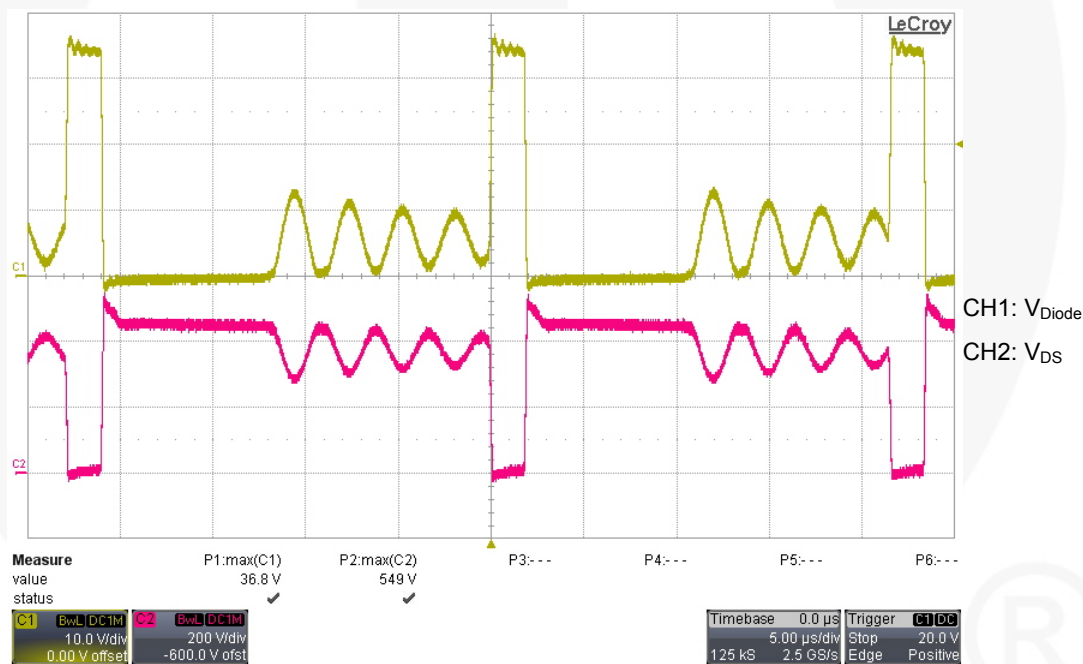

Figure 20. 264V/50Hz at Maximum Load

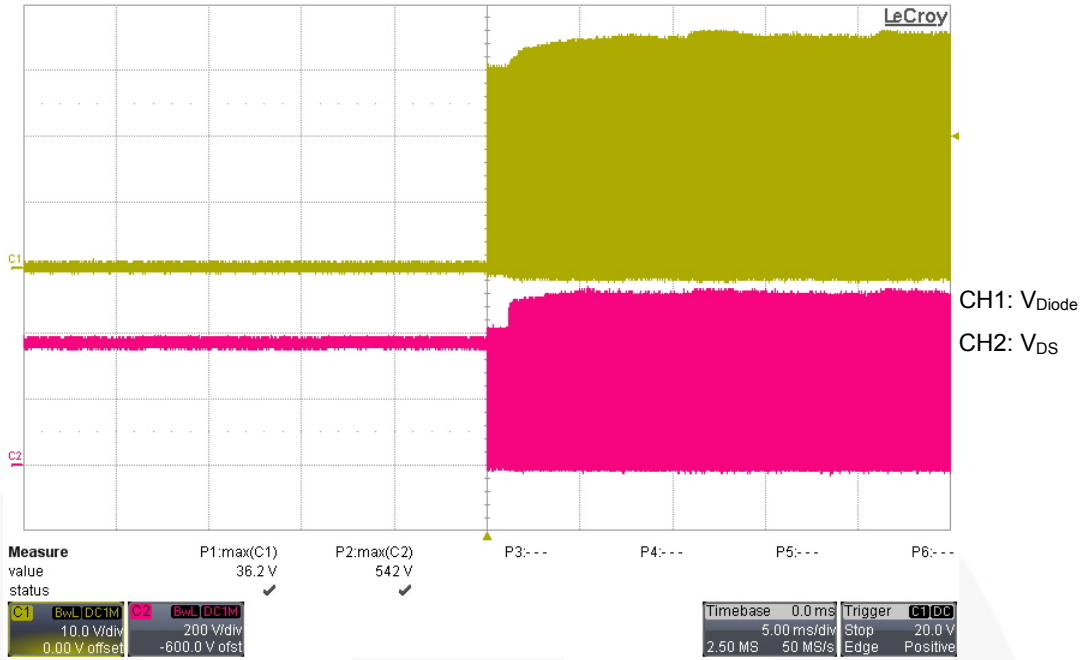

Figure 21. 264V/50Hz at Maximum Load Startup

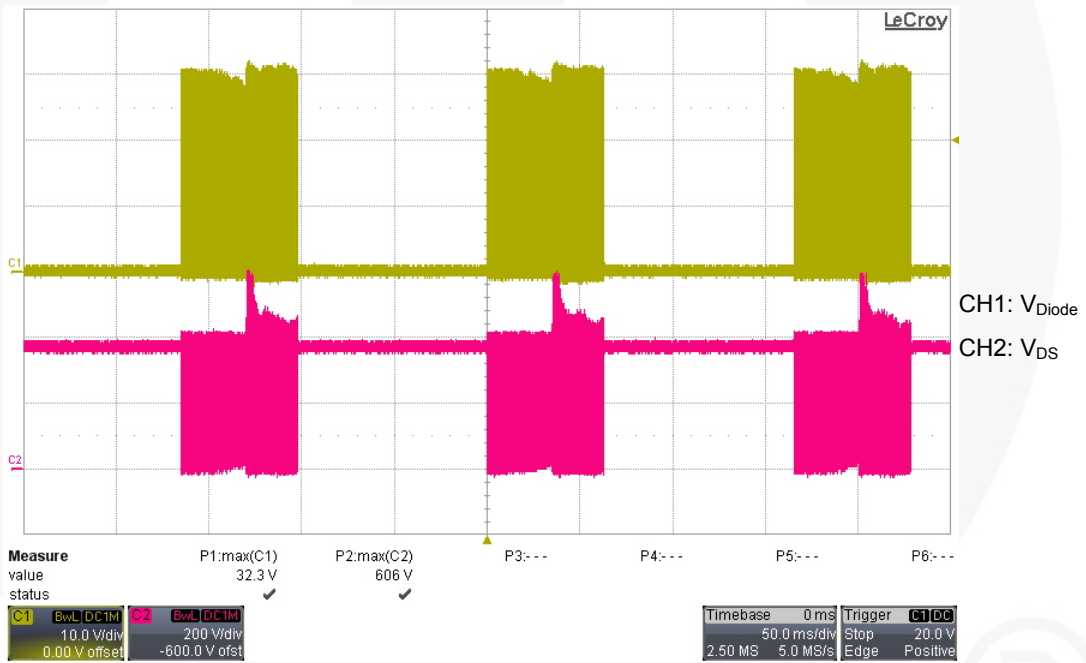

Figure 22. 264V/50Hz at Maximum Load Short

3.14. Constant Voltage (CV) and Constant Current (CC) Curves

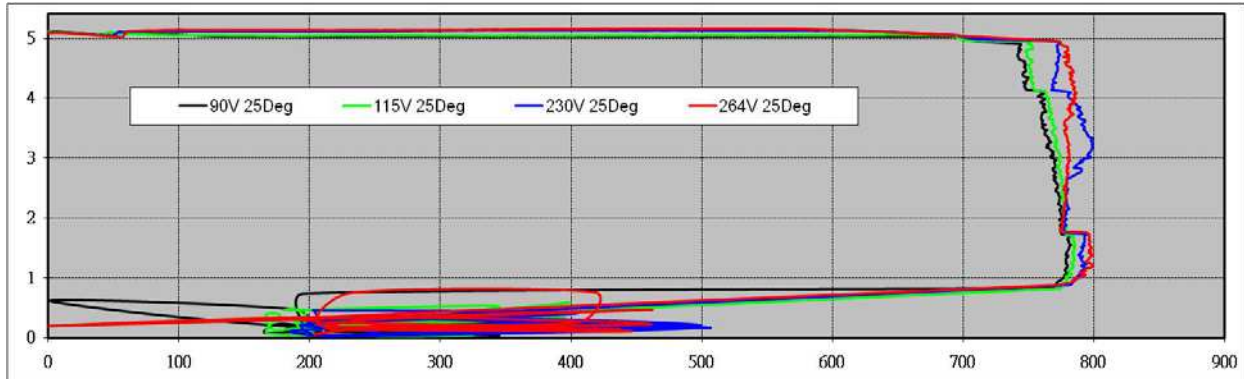

Figure 23. Constant Current Curve

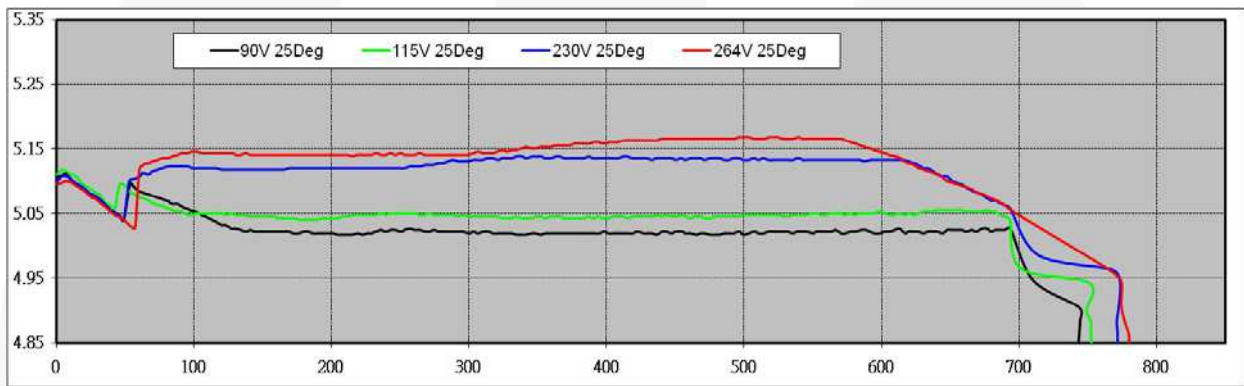

Figure 24. Constant Voltage Curve

3.15. EMI Test (Output with 1.8M Cable Wire)

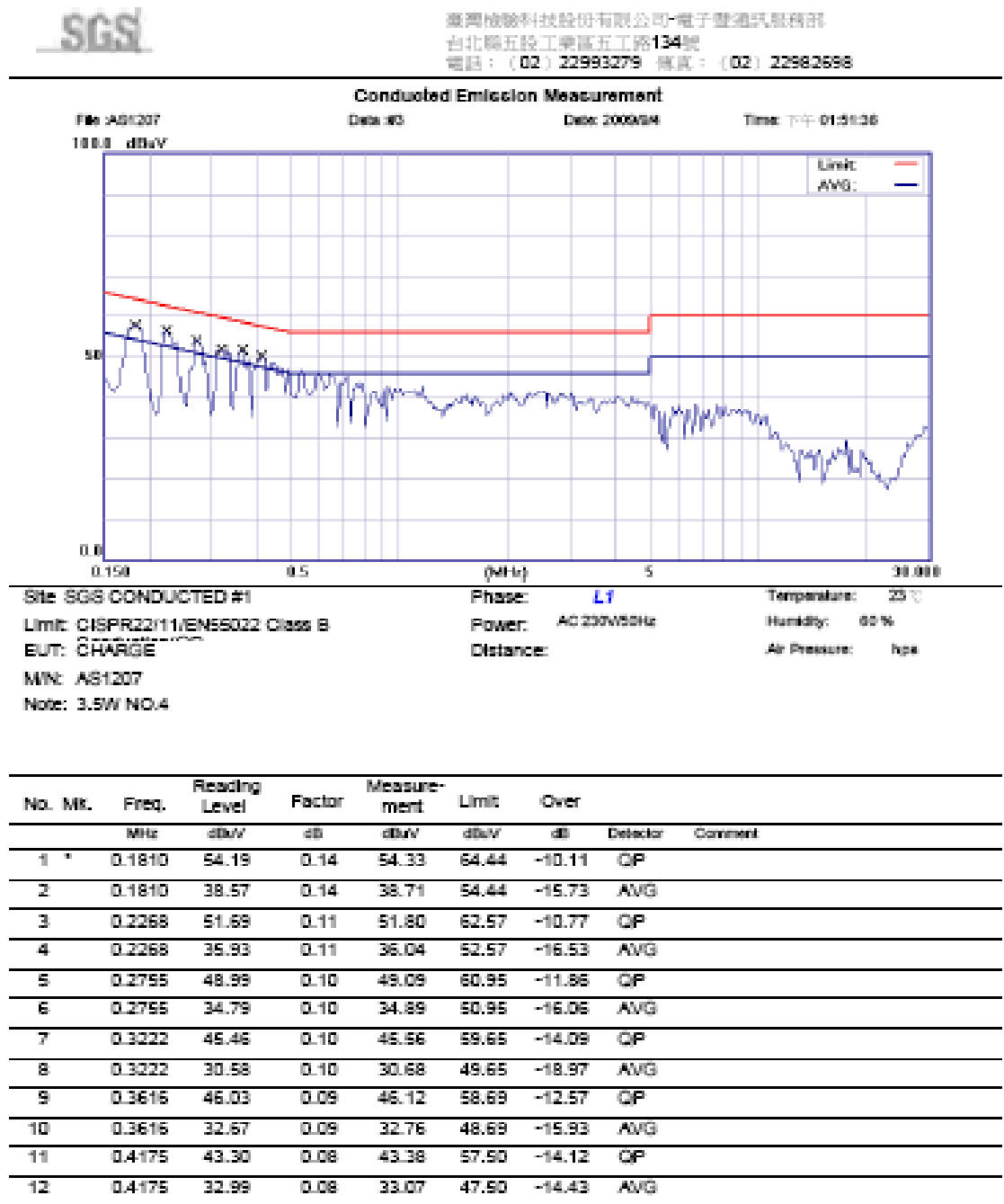

Figure 25. Conduction-Line at 230V_{AC}



臺灣檢驗科技股份有限公司-電子暨通訊服務部
台北縣五股工業區五工路134號
電話：(02) 22993279 傳真：(02) 22983598

Conducted Emission Measurement

File: AS1207 Date: #4 Date: 2009/04 Time: 下午 01:55:39

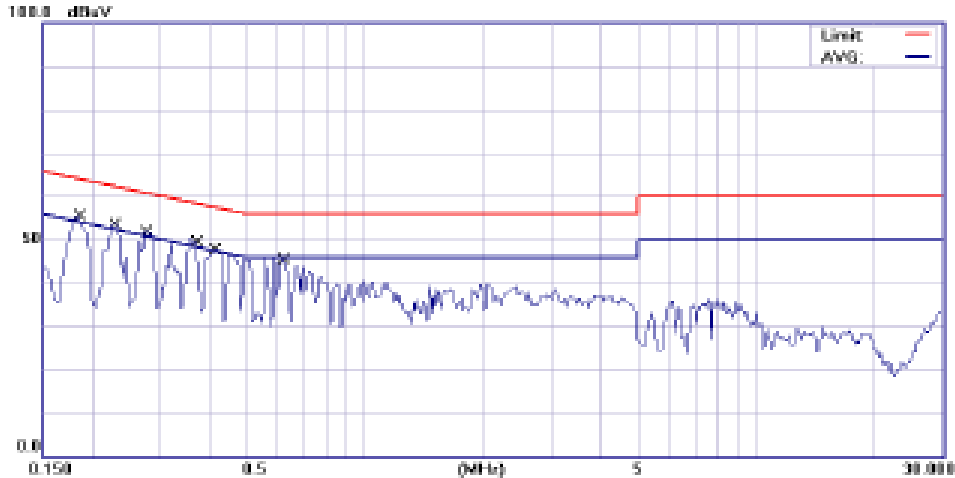

Site: SGS CONDUCTED #1 Phase: *N* Temperature: 23 °C
 Limit: CISPR22/11/EN55022 Class B Power: AC 230V50Hz Humidity: 69 %
 EUT: CHARGE Distance: Air Pressure: hpa
 Mfr: AS1207
 Note: 3.5W NO.4

No.	Mk.	Freq.	Reading Level	Factor	Measurement	Limit	Over	Detector	Comment
		MHz	dBuV	dB	dBuV	dBuV	dB		
1	*	0.1856	51.68	0.16	51.84	64.23	-12.39	QP	
2		0.1856	34.45	0.16	34.61	54.23	-19.62	AVG	
3		0.2288	49.88	0.14	50.02	62.49	-12.47	QP	
4		0.2288	32.66	0.14	32.80	52.49	-19.69	AVG	
5		0.2777	46.55	0.13	46.68	60.88	-14.20	QP	
6		0.2777	28.74	0.13	28.87	50.88	-22.01	AVG	
7		0.3668	44.19	0.11	44.30	58.57	-14.27	QP	
8		0.3668	27.88	0.11	27.99	48.57	-20.58	AVG	
9		0.4138	41.17	0.11	41.28	57.57	-16.29	QP	
10		0.4138	27.50	0.11	27.61	47.57	-19.96	AVG	
11		0.6199	38.27	0.10	38.37	56.00	-17.63	QP	
12		0.6199	18.72	0.10	18.82	46.00	-27.18	AVG	

Figure 26. Conduction- Neutral at 230V_{AC}



3.16. Surge test

3.16.1. Test Condition

- Maximum Load, $V_{IN} (AC) = 230V 50Hz$
- L-PE: (Positive & Negative) 1KV~4.4KV
- N-PE: (Positive & Negative) 1KV~4.4KV
- L-N: (Positive & Negative) 500V~1KV

3.16.2. Test Result

Mode	Polarity	Phase	Voltage	Condition
L-PE	+/-	0°	4.4KV	Pass
	+/-	90°		Pass
	+/-	180°		Pass
	+/-	270°		Pass
N-PE	+/-	0°	4.4KV	Pass
	+/-	90°		Pass
	+/-	180°		Pass
	+/-	270°		Pass
L-N	+/-	0°	2.0KV	Pass
	+/-	90°		Pass
	+/-	180°		Pass
	+/-	270°		Pass

3.17. ESD Test

3.17.1. Test Condition

- Maximum Load, $V_{IN} (AC) = 230V 50Hz$
- Air: (Positive & Negative) 8KV~16KV
- Contact: (Positive & Negative) 4KV~8KV

3.17.2. Test Result

Mode	Polarity	Voltage	Condition
Air	+/-	16.5KV	Pass
Contact	+/-	8.8KV	Pass

4. Photographs

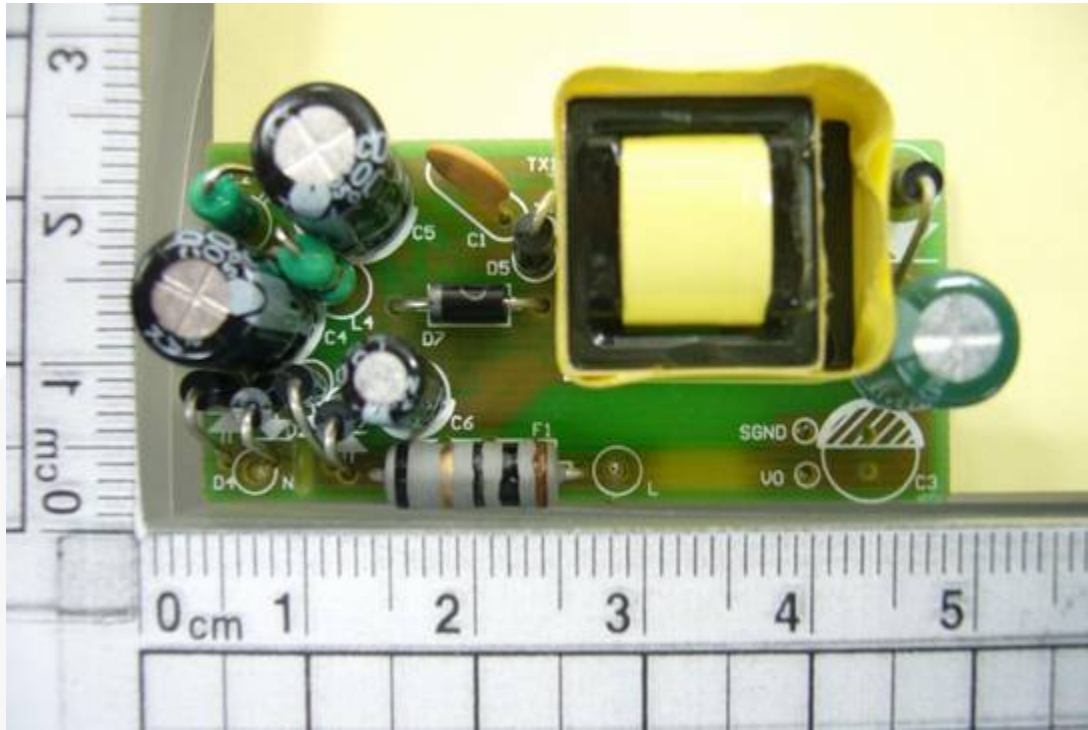

Figure 27. Vertical View

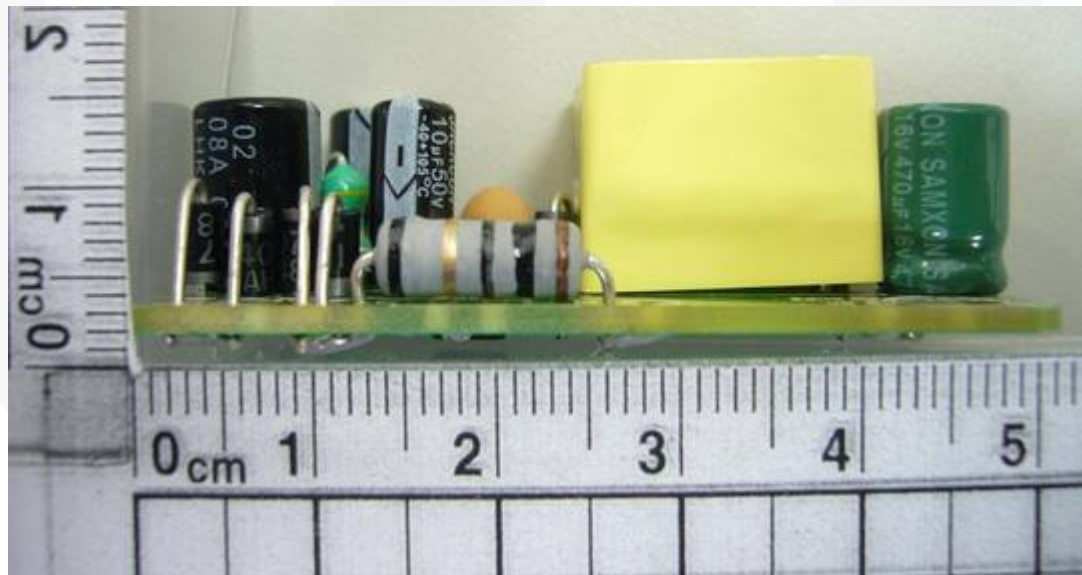

Figure 28. Lateral View

5. Circuit Schematic

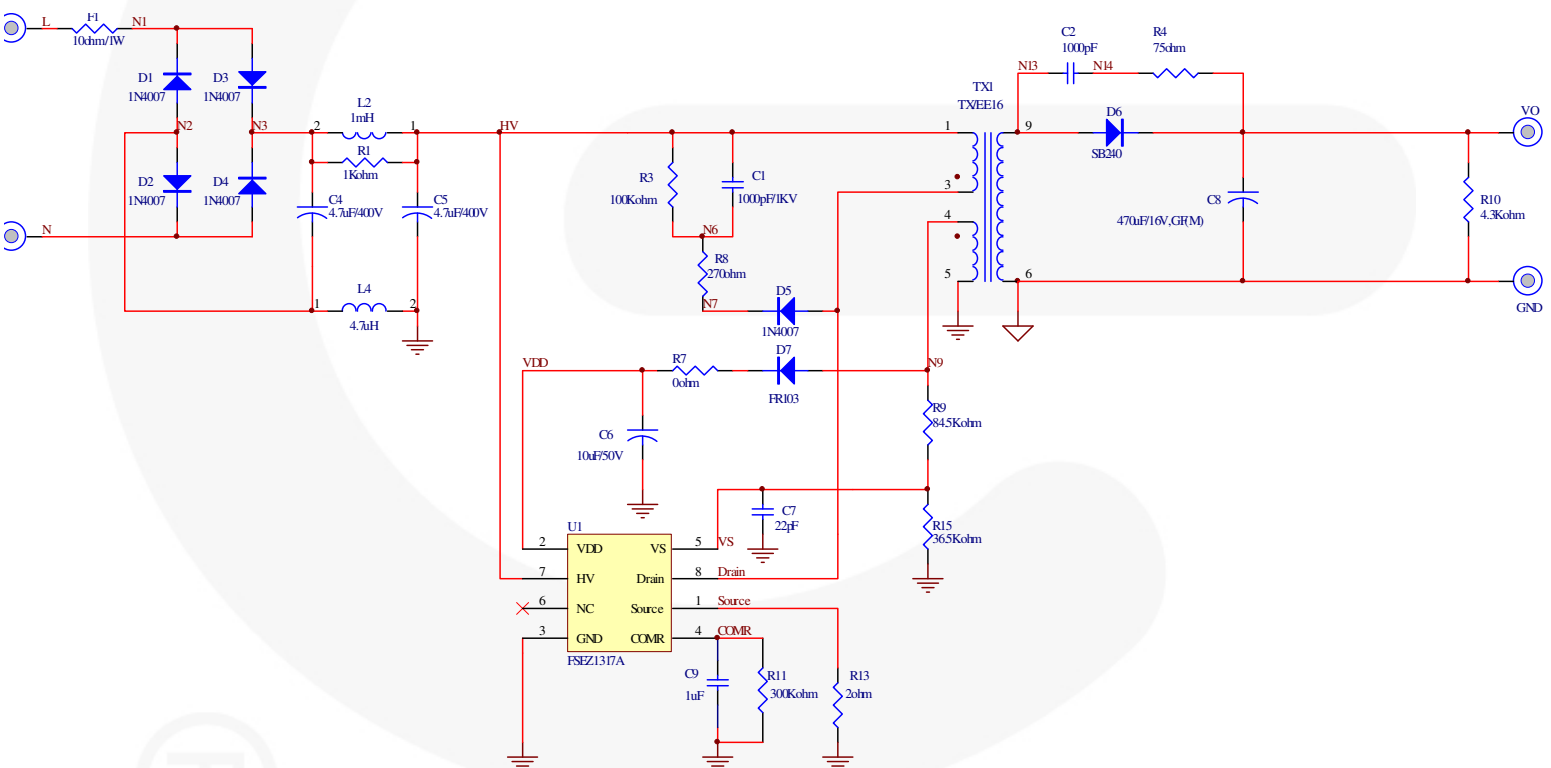

Figure 29. Circuit Schematic