



Chipsmall Limited consists of a professional team with an average of over 10 year of expertise in the distribution of electronic components. Based in Hongkong, we have already established firm and mutual-benefit business relationships with customers from,Europe,America and south Asia,supplying obsolete and hard-to-find components to meet their specific needs.

With the principle of "Quality Parts,Customers Priority,Honest Operation,and Considerate Service",our business mainly focus on the distribution of electronic components. Line cards we deal with include Microchip,ALPS,ROHM,Xilinx,Pulse,ON,Everlight and Freescale. Main products comprise IC,Modules,Potentiometer,IC Socket,Relay,Connector.Our parts cover such applications as commercial,industrial, and automotives areas.

We are looking forward to setting up business relationship with you and hope to provide you with the best service and solution. Let us make a better world for our industry!



Contact us

Tel: +86-755-8981 8866 Fax: +86-755-8427 6832

Email & Skype: info@chipsmall.com Web: www.chipsmall.com

Address: A1208, Overseas Decoration Building, #122 Zhenhua RD., Futian, Shenzhen, China



60 V field-effect rectifier diode

Datasheet - production data

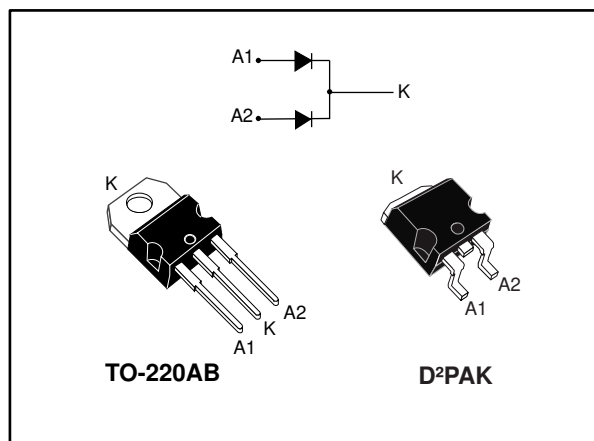
Features

- ST advanced rectifier process
- Stable leakage current over reverse voltage
- Reduced leakage current
- Low forward voltage drop
- High frequency operation

Description

The device is based on a proprietary technology that achieves the best in class V_F/I_R trade-off for a given silicon surface.

This 60 V rectifier has been optimized for use in confined applications where both efficiency and thermal performance are key.

This device is suitable for use in adapters and chargers.

Table 1: Device summary

Symbol	Value
$I_{F(AV)}$	2 x 10 A
V_{RRM}	60 V
V_F (typ.)	0.39 V
T_j (max.)	175 °C

1 Characteristics

Table 2: Absolute ratings (limiting values at 25 °C, per diode, unless otherwise specified)

Symbol	Parameter		Value	Unit	
V _{RRM}	Repetitive peak reverse voltage		60	V	
I _{F(RMS)}	Forward rms current		30	A	
I _{F(AV)}	Average forward current $\delta = 0.5$, square wave	T _C = 155 °C	Per diode	10	A
			Per device	20	
I _{FSM}	Surge non repetitive forward current	t _p = 10 ms sinusoidal	130	A	
T _{stg}	Storage temperature range		-65 to +175	°C	
T _j	Maximum operating junction temperature ⁽¹⁾		+175	°C	

Notes:

⁽¹⁾(dP_{tot}/dT_j) < (1/R_{th(j-a)}) condition to avoid thermal runaway for a diode on its own heatsink.

Table 3: Thermal resistance parameters

Symbol	Parameter		Max. value	Unit
R _{th(j-c)}	Junction to case	Per diode	2.2	°C/W
		Per device	1.3	
R _{th(c)}	Coupling		0.4	

Table 4: Static electrical characteristics, per diode

Symbol	Parameter	Test conditions		Min.	Typ.	Max.	Unit
I _R ⁽¹⁾	Reverse leakage current	T _j = 25 °C	V _R = V _{RRM}	-		200	μA
		T _j = 125 °C		-	10	20	mA
		T _j = 125 °C	V _R = 45 V	-	6	12	
V _F ⁽²⁾	Forward voltage drop	T _j = 25 °C	I _F = 2 A	-	0.34	0.38	V
		T _j = 125 °C		-	0.28	0.315	
		T _j = 25 °C	I _F = 5 A	-	0.415	0.465	
		T _j = 125 °C		-	0.39	0.435	
		T _j = 25 °C	I _F = 10 A	-	0.52	0.575	
		T _j = 125 °C		-	0.525	0.585	

Notes:

⁽¹⁾Pulse test: t_p = 5 ms, $\delta < 2\%$

⁽²⁾Pulse test: t_p = 380 μs, $\delta < 2\%$

To evaluate the conduction losses use the following equation:

$$P = 0.285 \times I_{F(AV)} + 0.03 \times I_{F(RMS)}^2$$

1.1 Characteristics (curves)

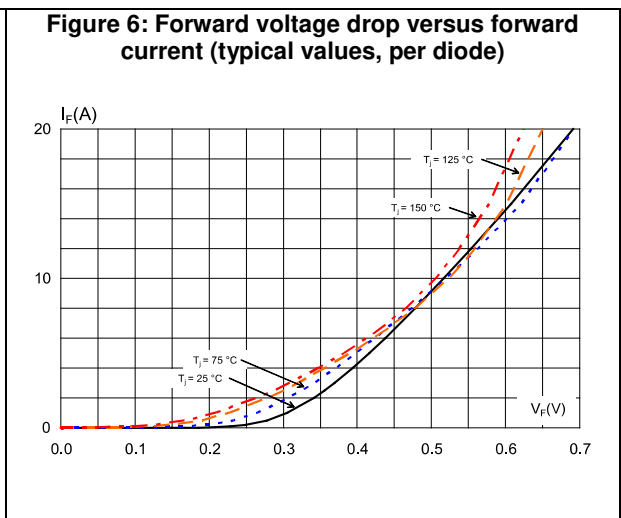
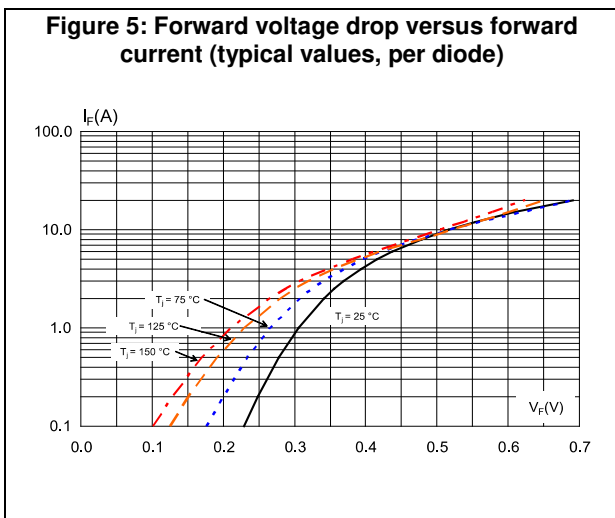
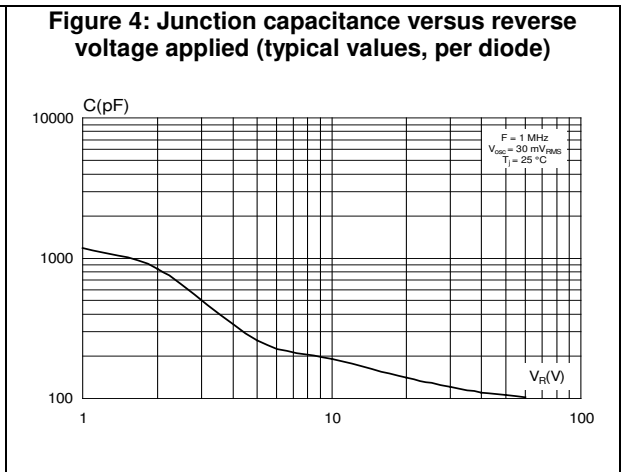
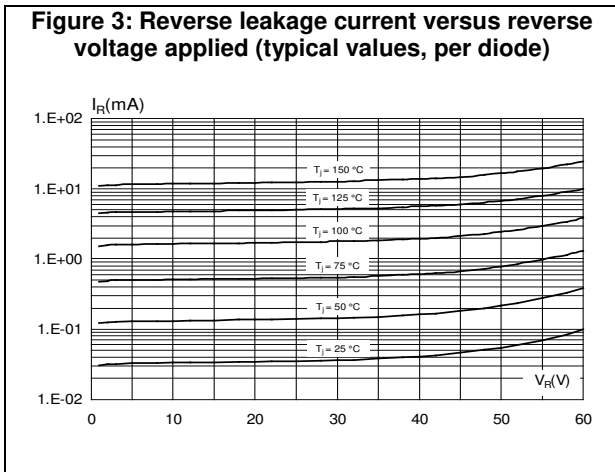
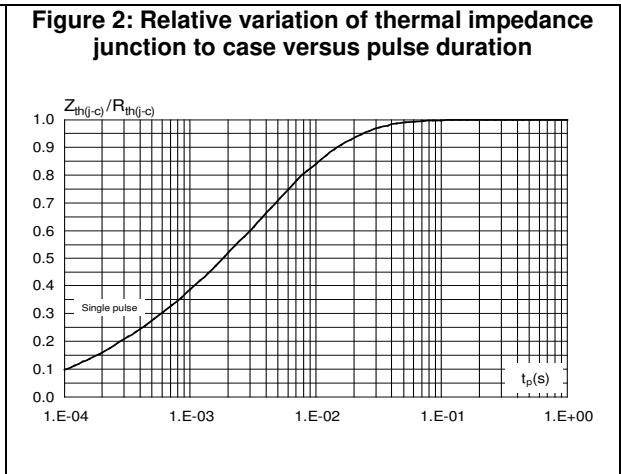
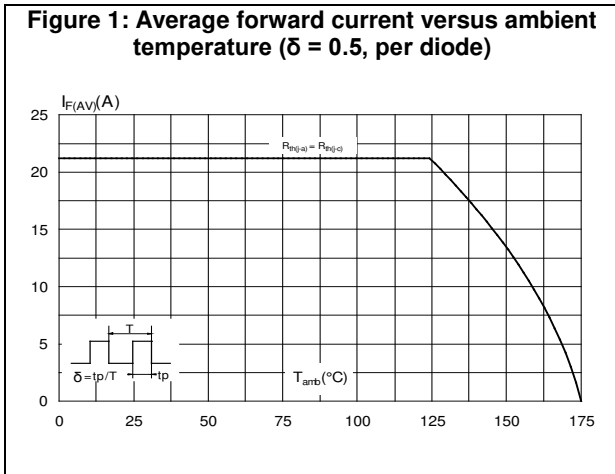
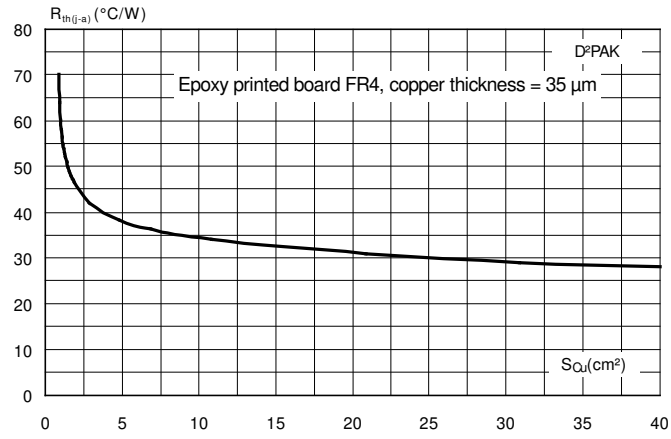

Figure 7: Thermal resistance junction to ambient versus copper surface under tab for D²PAK (typical values)



2 Package information

In order to meet environmental requirements, ST offers these devices in different grades of ECOPACK® packages, depending on their level of environmental compliance. ECOPACK® specifications, grade definitions and product status are available at: www.st.com. ECOPACK® is an ST trademark.

- Cooling method: by conduction (C)
- Epoxy meets UL94, V0
- Recommended torque value: 0.55 N·m (for TO-220AB)
- Maximum torque value: 0.6 N·m (for TO-220AB)

2.1 TO-220AB package information

Figure 8: TO-220AB package outline

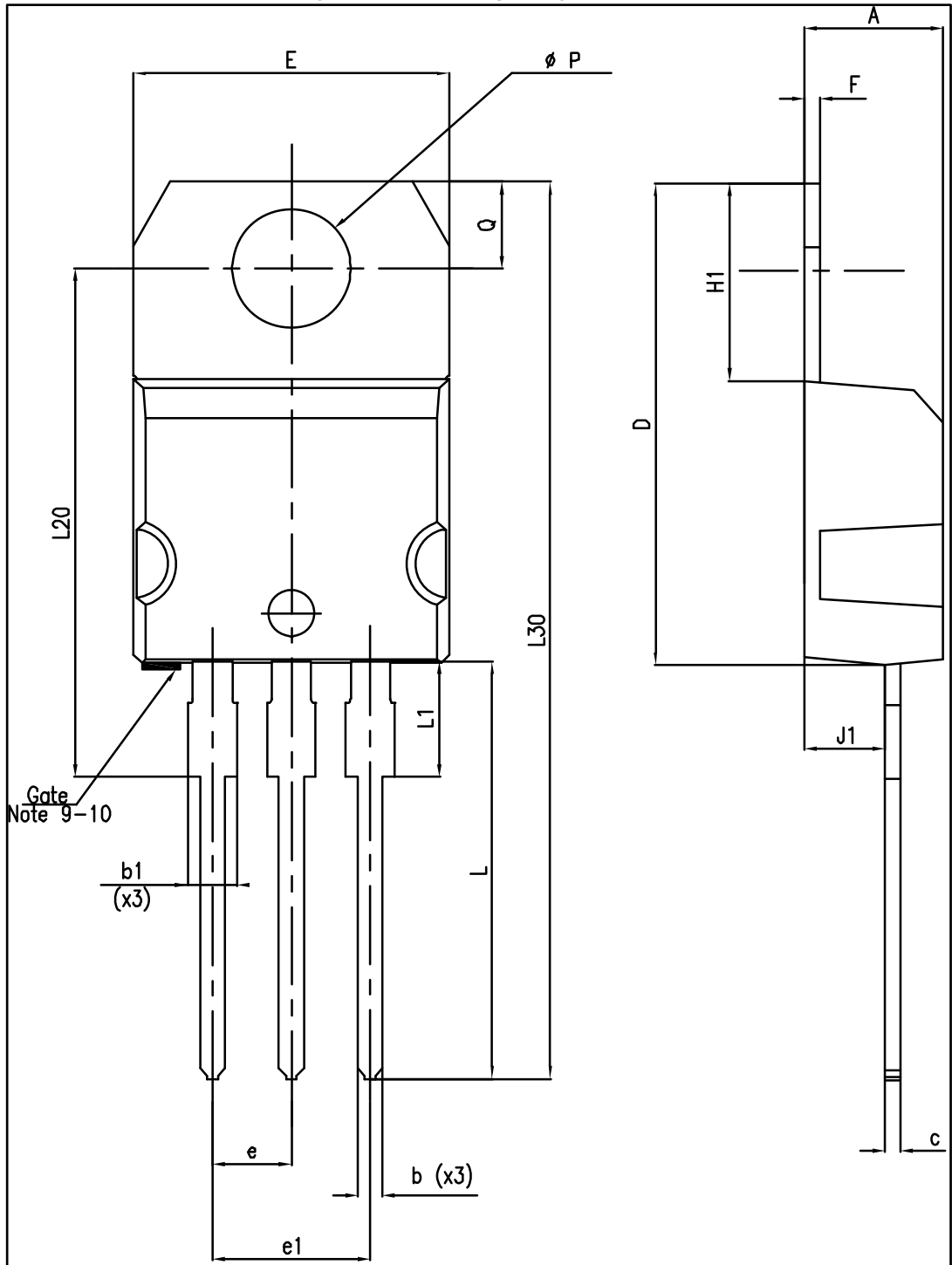

Table 5: TO-220AB package mechanical data

Ref.	Dimensions			
	Millimeters		Inches	
	Min.	Max.	Min.	Max.
A	4.40	4.60	0.173	0.181
b	0.61	0.88	0.024	0.035
b1	1.14	1.70	0.045	0.067
c	0.48	0.70	0.019	0.028
D	15.25	15.75	0.600	0.620
E	10.00	10.40	0.394	0.409
e	2.40	2.70	0.094	0.106
e1	4.95	5.15	0.195	0.203
F	0.51	0.60	0.020	0.024
J1	2.40	2.72	0.094	0.107
H1	6.20	6.60	0.244	0.256
L	13.00	14.00	0.512	0.551
L1	3.50	3.93	0.138	0.155
L20	16.40 typ.		0.646 typ.	
L30	28.90 typ.		1.138	
Ø P	3.75	3.85	0.148	0.156
Q	2.65	2.95	0.104	0.116

2.2 D²PAK package information

Figure 9: D²PAK package outline

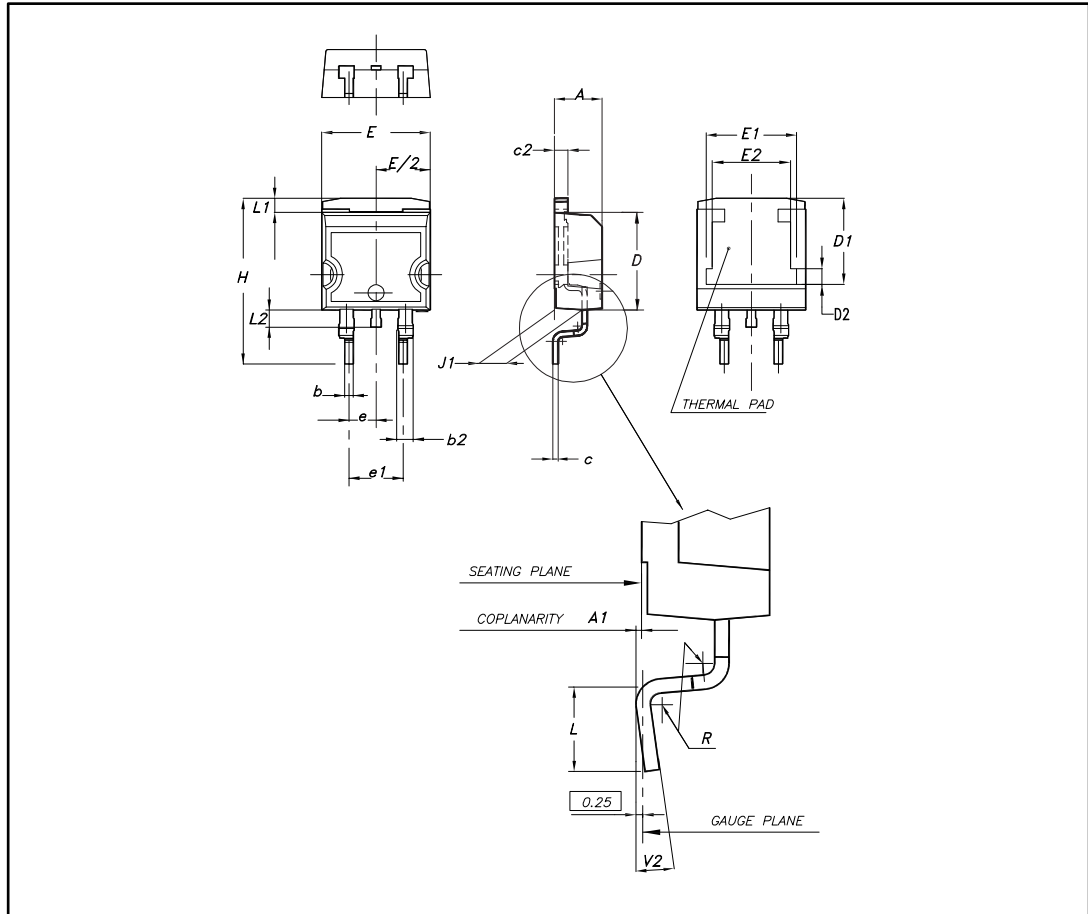
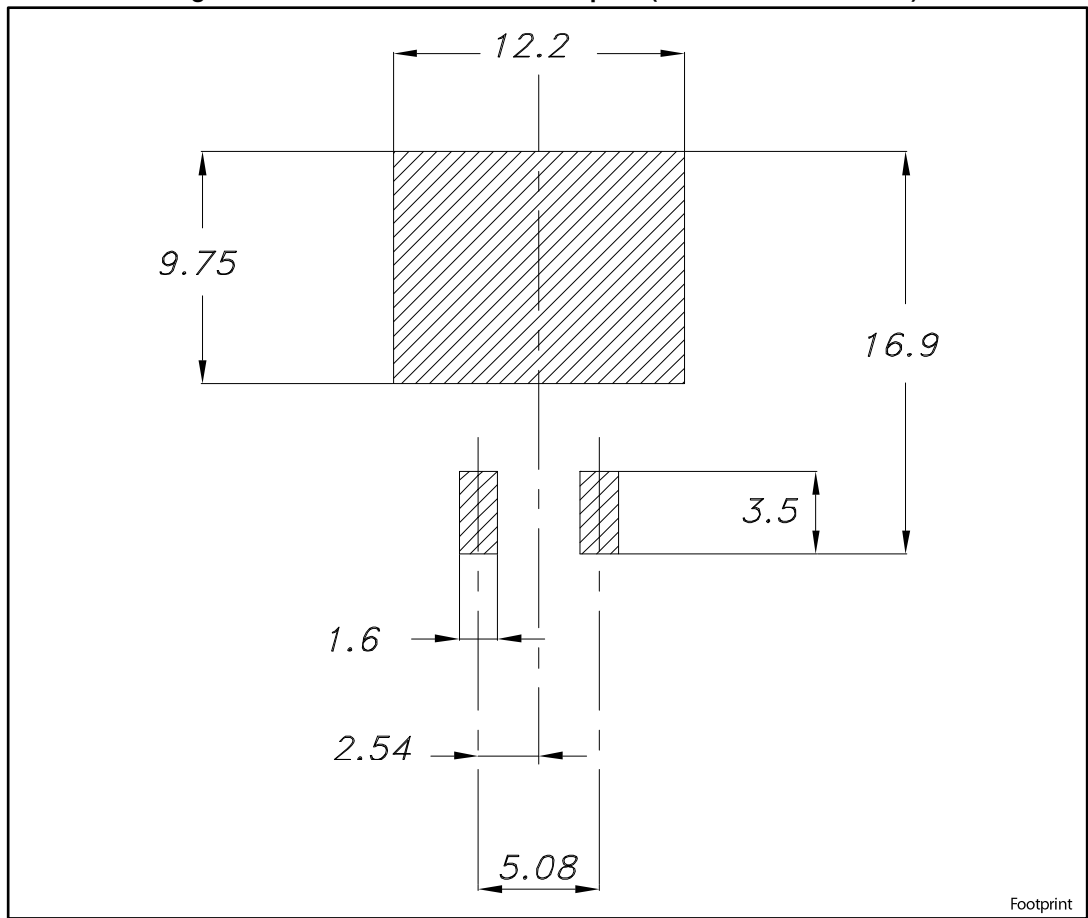

Table 6: D²PAK package mechanical data

Ref.	Dimensions					
	Millimeters			Inches		
	Min.	Typ.	Max.	Min.	Typ.	Max.
A	4.40		4.60	0.173		0.181
A1	0.03		0.23	0.001		0.009
b	0.70		0.93	0.028		0.037
b2	1.14		1.70	0.045		0.067
c	0.45		0.60	0.018		0.024
c2	1.23		1.36	0.048		0.053
D	8.95		9.35	0.352		0.368
D1	7.50	7.75	8.00	0.295	0.305	0.315
D2	1.10	1.30	1.50	0.043	0.051	0.060
E	10		10.40	0.394		0.409
E1	8.50	8.70	8.90	0.335	0.343	0.346
E2	6.85	7.05	7.25	0.266	0.278	0.282
e		2.54			0.100	
e1	4.88		5.28	0.190		0.205
H	15		15.85	0.591		0.624
J1	2.49		2.69	0.097		0.106
L	2.29		2.79	0.090		0.110
L1	1.27		1.40	0.049		0.055
L2	1.30		1.75	0.050		0.069
R		0.4			0.015	
V2	0°		8°	0°		8°

Figure 10: D²PAK recommended footprint (dimensions are in mm)



3 Ordering information

Table 7: Ordering information

Order code	Marking	Package	Weight	Base qty.	Delivery mode
FERD20H60CTS	FD20H60CTS	TO-220AB	1.38 g	50	Tube
FERD20H60CG-TR	FD20H60CG	D ² PAK	1.43 g	1000	Tape and reel

4 Revision history

Table 8: Document revision history

Date	Revision	Changes
01-Sep-2017	1	Initial release.

IMPORTANT NOTICE – PLEASE READ CAREFULLY

STMicroelectronics NV and its subsidiaries ("ST") reserve the right to make changes, corrections, enhancements, modifications, and improvements to ST products and/or to this document at any time without notice. Purchasers should obtain the latest relevant information on ST products before placing orders. ST products are sold pursuant to ST's terms and conditions of sale in place at the time of order acknowledgement.

Purchasers are solely responsible for the choice, selection, and use of ST products and ST assumes no liability for application assistance or the design of Purchasers' products.

No license, express or implied, to any intellectual property right is granted by ST herein.

Resale of ST products with provisions different from the information set forth herein shall void any warranty granted by ST for such product.

ST and the ST logo are trademarks of ST. All other product or service names are the property of their respective owners.

Information in this document supersedes and replaces information previously supplied in any prior versions of this document.

© 2017 STMicroelectronics – All rights reserved