



Chipsmall Limited consists of a professional team with an average of over 10 year of expertise in the distribution of electronic components. Based in Hongkong, we have already established firm and mutual-benefit business relationships with customers from,Europe,America and south Asia,supplying obsolete and hard-to-find components to meet their specific needs.

With the principle of “Quality Parts,Customers Priority,Honest Operation,and Considerate Service”,our business mainly focus on the distribution of electronic components. Line cards we deal with include Microchip,ALPS,ROHM,Xilinx,Pulse,ON,Everlight and Freescale. Main products comprise IC,Modules,Potentiometer,IC Socket,Relay,Connector.Our parts cover such applications as commercial,industrial, and automotives areas.

We are looking forward to setting up business relationship with you and hope to provide you with the best service and solution. Let us make a better world for our industry!



Contact us

Tel: +86-755-8981 8866 Fax: +86-755-8427 6832

Email & Skype: info@chipsmall.com Web: www.chipsmall.com

Address: A1208, Overseas Decoration Building, #122 Zhenhua RD., Futian, Shenzhen, China



Handle Series

FG16-02

FG16-05

Material and surface:

Handle shanks made of high strength polyamide PA 6, black with fine structure. Handle ledge made of lathed PVC black.

Function elements:

FG16-02:

Push button 1 (change-over contact)
Push button 2 (NO contact)
2 LED's.

FG16-05:

Emergency-stop (2 NC contacts)
Push button 1 (change-over contact)
Push button 2 (NO contact)
2 LED's

FG16-00:

Basic handle, as FG16-02 and FG16-05, but without switch elements as counter-handle.

Connection:

8-pole or 12-pole connector positioned at the tubular axle of the handle ledge in the handle shank.
Coupling with 10 m ready-made cable available as accessory.

Protection class:

IP 65 with coupling screwed on.

Note:

With connection cable other push button assignment or other handle lengths on request.



FG16-00.180.84

Counter-handle without electrical function elements.



Typ FG16-02



Typ FG16-05

Switching function	Order no.
without switch elements	FG16-00.180.84
2 push button and 2 LED's	FG16-02S.180.84
Emergency stop, 2 push button and 2 LED's	FG16-05S.180.84
Other handle lengths on request	

Handle accessories

Coupling with cable
8-pole (M12 x 1) 12-pole (M12 x 1)

	L	Order no.	Order no.
	10 m	FZ-KS.G08.10	FZ-KS.G12.10
	10 m	FZ-KS.W08.10	FZ-KS.W12.10



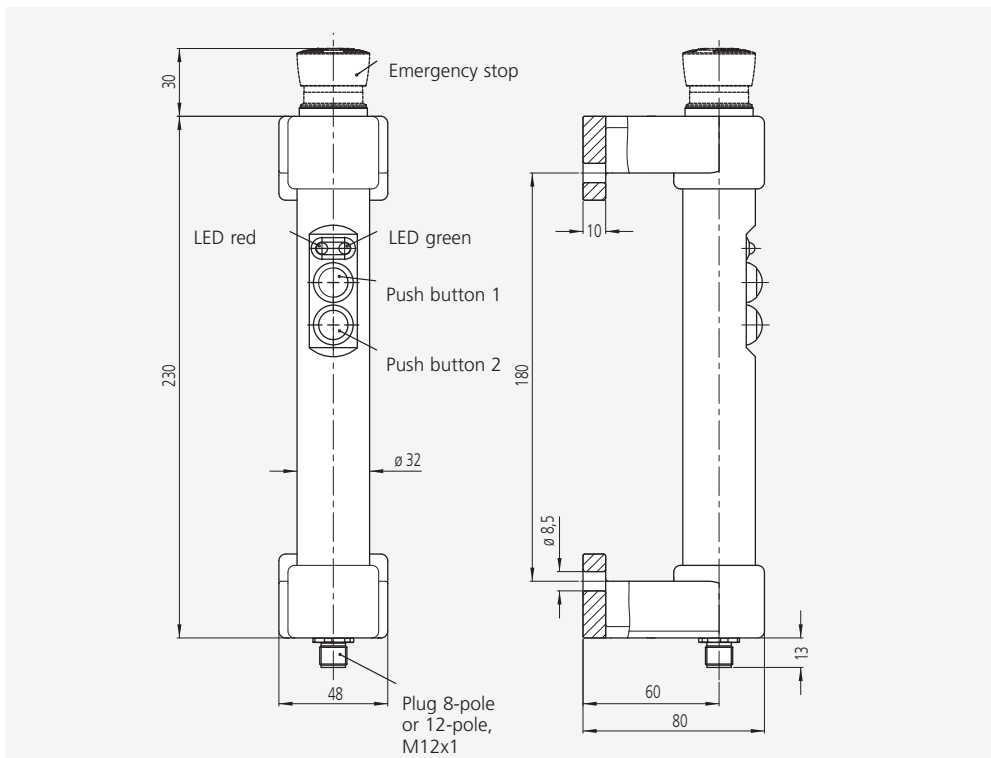

Technical data

Typ	FG16-02	FG16-05
Emergency stop (2 NC contacts)	without	
Push button 1 (1 change-over contact)		
Push button 2 (1 NO contact)		
LED red/green		
Emergency stop	-	1-42 V AC/DC max. 100 mA
Push buttons	24 V AC/DC max. 1,5 A	
Operating voltage LED	24 V DC (12 V optional)	
Connection type	8-pole M12 x 1	12-pole M12 x 1
Connector assignment (Plug side view)		

All dimensions in mm.