



Chipsmall Limited consists of a professional team with an average of over 10 year of expertise in the distribution of electronic components. Based in Hongkong, we have already established firm and mutual-benefit business relationships with customers from,Europe,America and south Asia,supplying obsolete and hard-to-find components to meet their specific needs.

With the principle of "Quality Parts,Customers Priority,Honest Operation,and Considerate Service",our business mainly focus on the distribution of electronic components. Line cards we deal with include Microchip,ALPS,ROHM,Xilinx,Pulse,ON,Everlight and Freescale. Main products comprise IC,Modules,Potentiometer,IC Socket,Relay,Connector.Our parts cover such applications as commercial,industrial, and automotives areas.

We are looking forward to setting up business relationship with you and hope to provide you with the best service and solution. Let us make a better world for our industry!



## Contact us

Tel: +86-755-8981 8866 Fax: +86-755-8427 6832

Email & Skype: info@chipsmall.com Web: www.chipsmall.com

Address: A1208, Overseas Decoration Building, #122 Zhenhua RD., Futian, Shenzhen, China



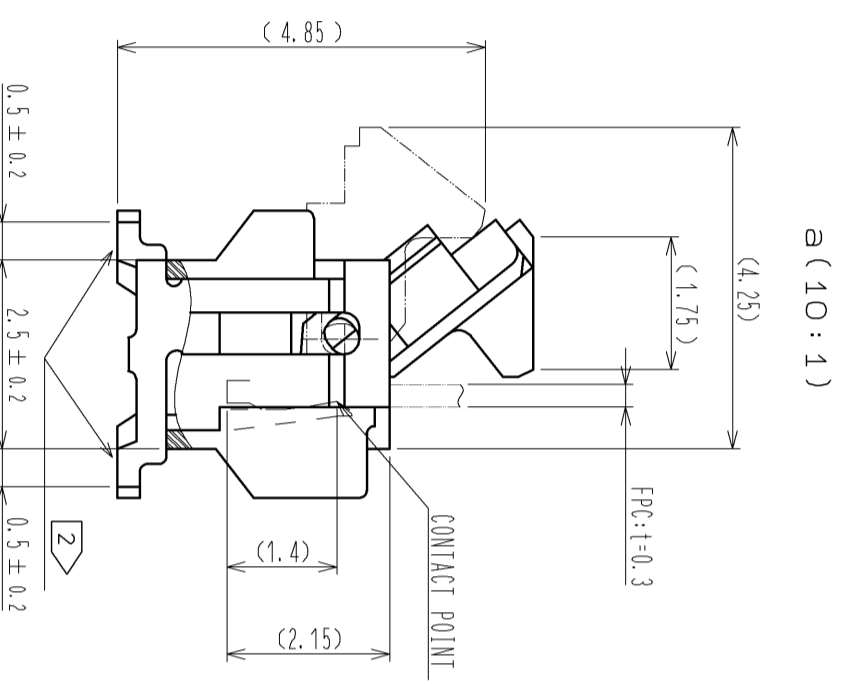
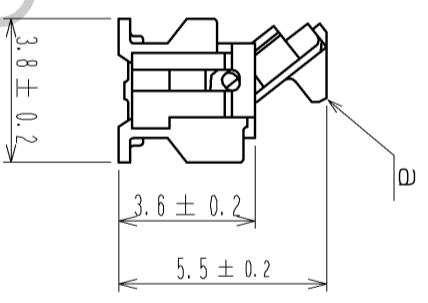
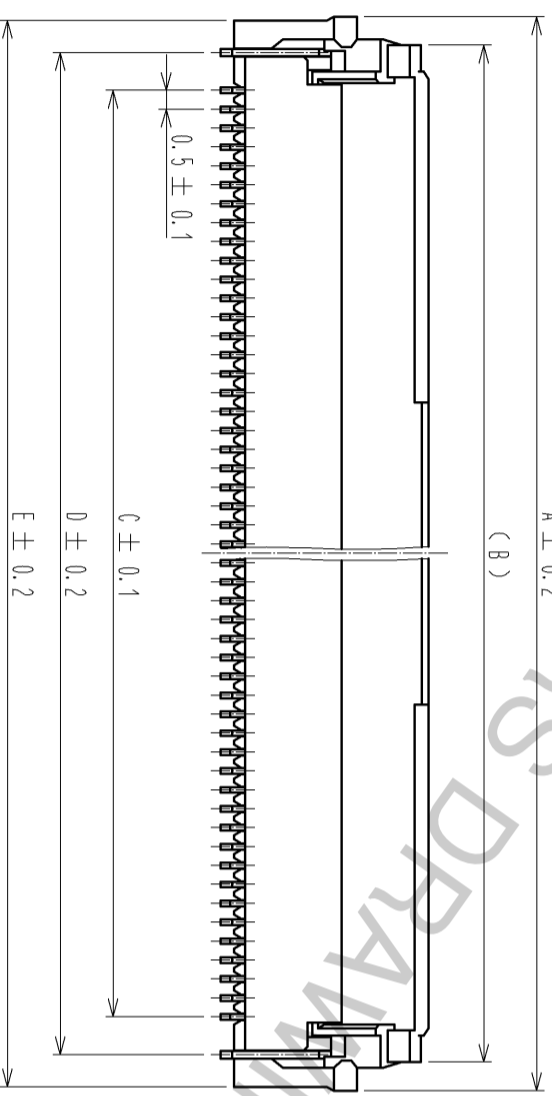
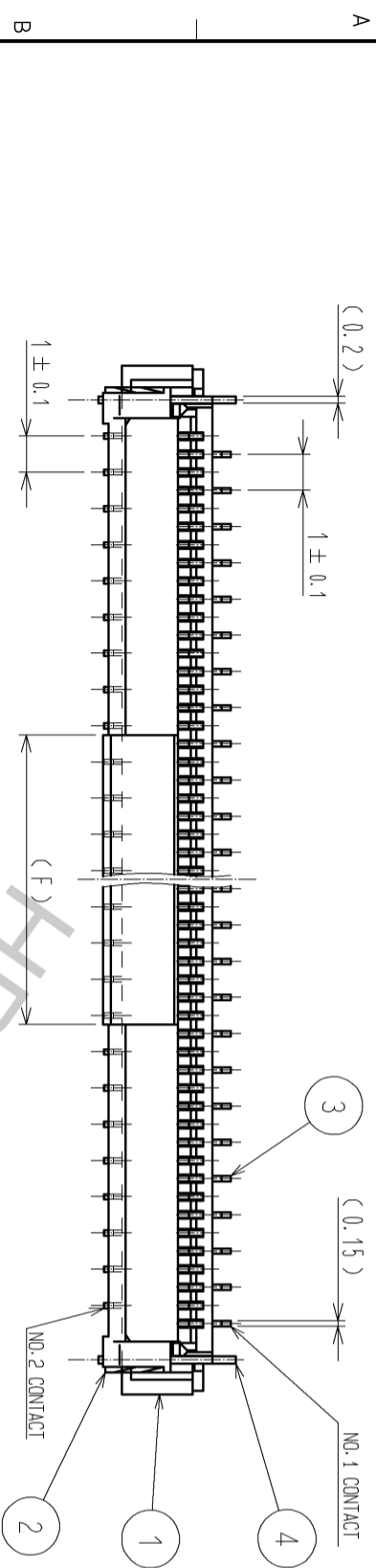

NOTE 1 THE DIMENSIONS IN PARENTHESES ARE FOR REFERENCE.

2 LEAD CO-PLANARITY SHALL BE 0.1 MAX.

3 SEE DIMENSION TABLE IN THE APPENDIX.

4 MATERIAL

NUMBER OF CONTACTS	MATERIAL
60	LCP
OTHER	POLYAMIDE

5 DIFFERENCES OF THE GOLD PLATED AREA DO NOT INFLUENCE ON THE PRODUCT PERFORMANCE.

6 'n' REPRESENTS THE NUMBER OF CONTACTS.

a (10:1)

HRS DRAWING FOR REFERENCE

NO.	MATERIAL	FINISH	REMARKS	NO.	MATERIAL	FINISH	REMARKS
1	PPS	(DEEP BROWN)	UL94V-0	5	POLYSTYRENE		
2	PPS	(DEEP BROWN)	UL94V-0	6	POLYESTER		
3	PHOSPHOR BRONZE	(OTHER)		7	POLYSTYRENE		
4	BRASS	TIN PLATING 1μm MIN. OVER NICKEL 1μm MIN. (CONTACT AREA, LEAD)		8	(CONNECTOR)		

UNITS	SCALE	COUNT	DESCRIPTION OF REVISIONS	DESIGNED	CHECKED	DATE
mm	5:1					

<b>HRS</b>		HIROSE ELECTRIC CO., LTD.	
APPROVED	: HS. SAKAMOTO	14.02.15	DRAWING NO.
CHECKED	: HS. SAKAMOTO	14.02.15	PART NO.
DESIGNED	: RT. IKEDA	14.02.13	CODE NO.
DRAWN	: NM. SANPEI	14.02.12	
EDC3-159266-03		FH12-*S-0.5SVA(54)	
CL586		1/5	

NUMBER OF CONTACTS: EVEN NUMBER

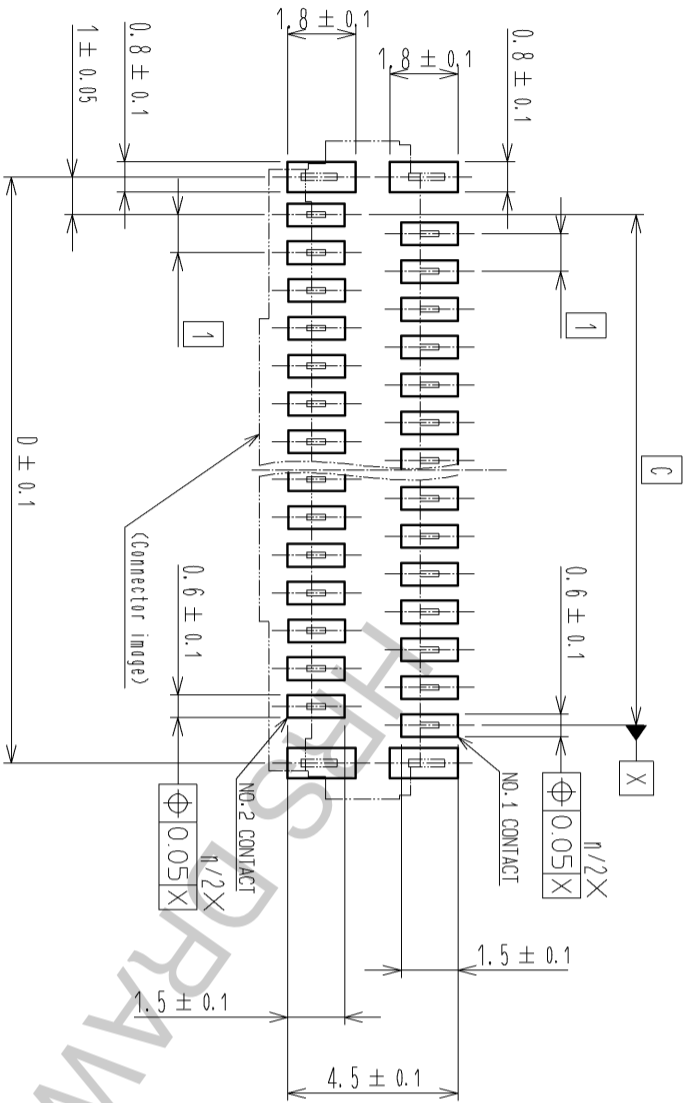

RECOMMENDED PCB MOUNTING PATTERN

NUMBER OF CONTACTS: ODD NUMBER

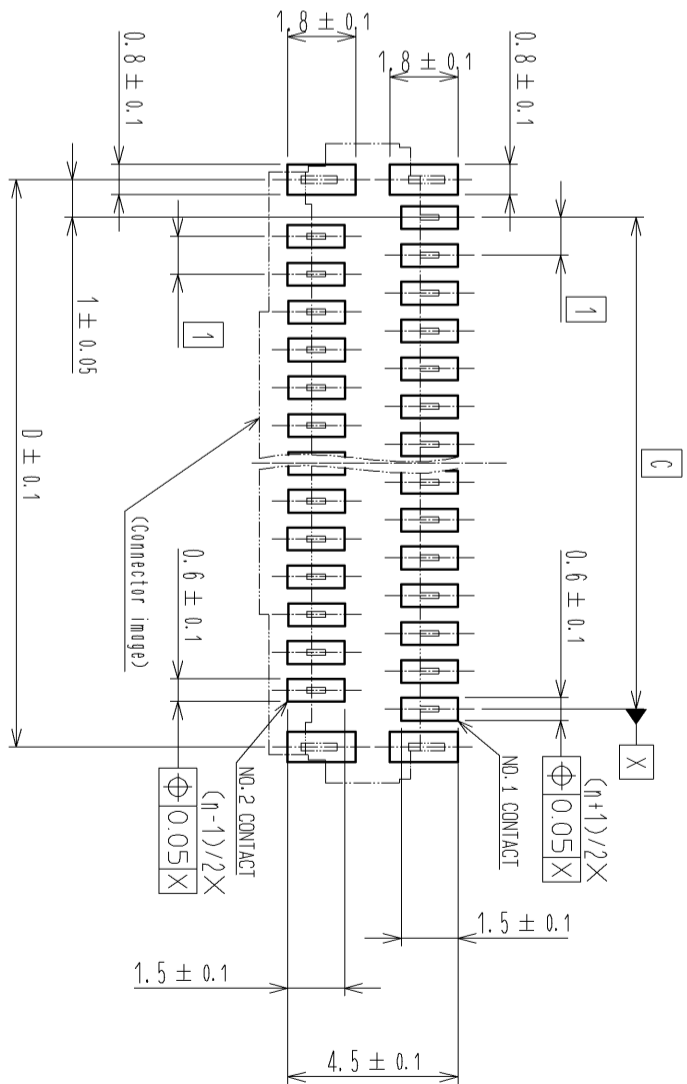

NUMBER OF CONTACTS: EVEN NUMBER

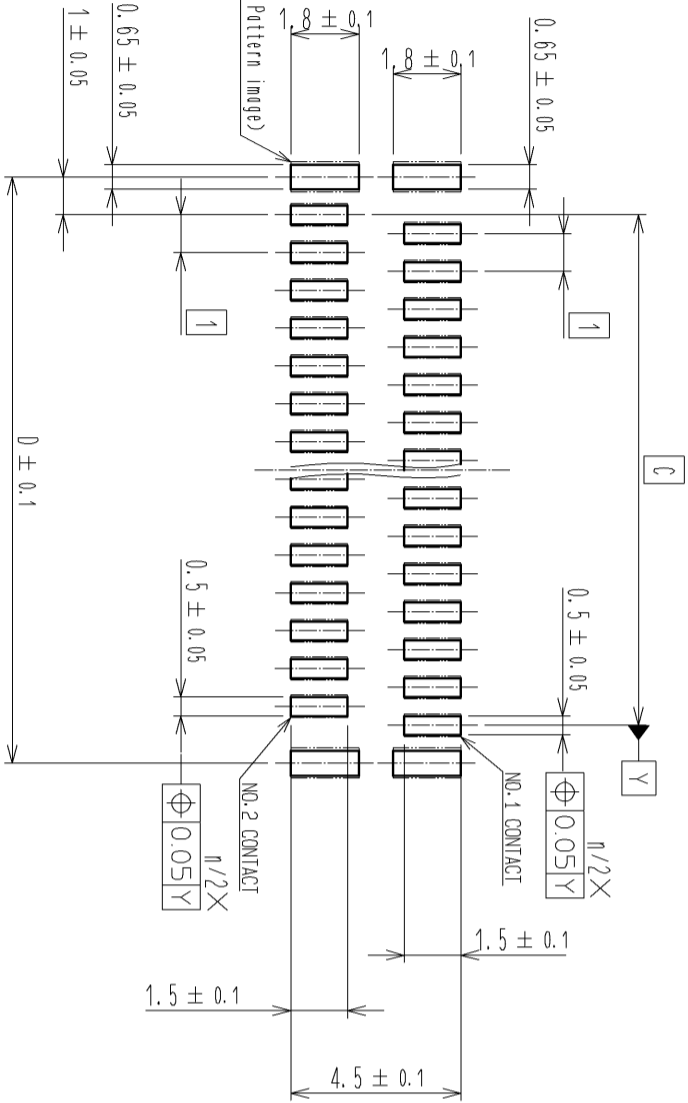

RECOMMENDED STENCIL PATTERN  
(RECOMMENDED STENCIL THICKNESS : t=0.15)

NUMBER OF CONTACTS: ODD NUMBER

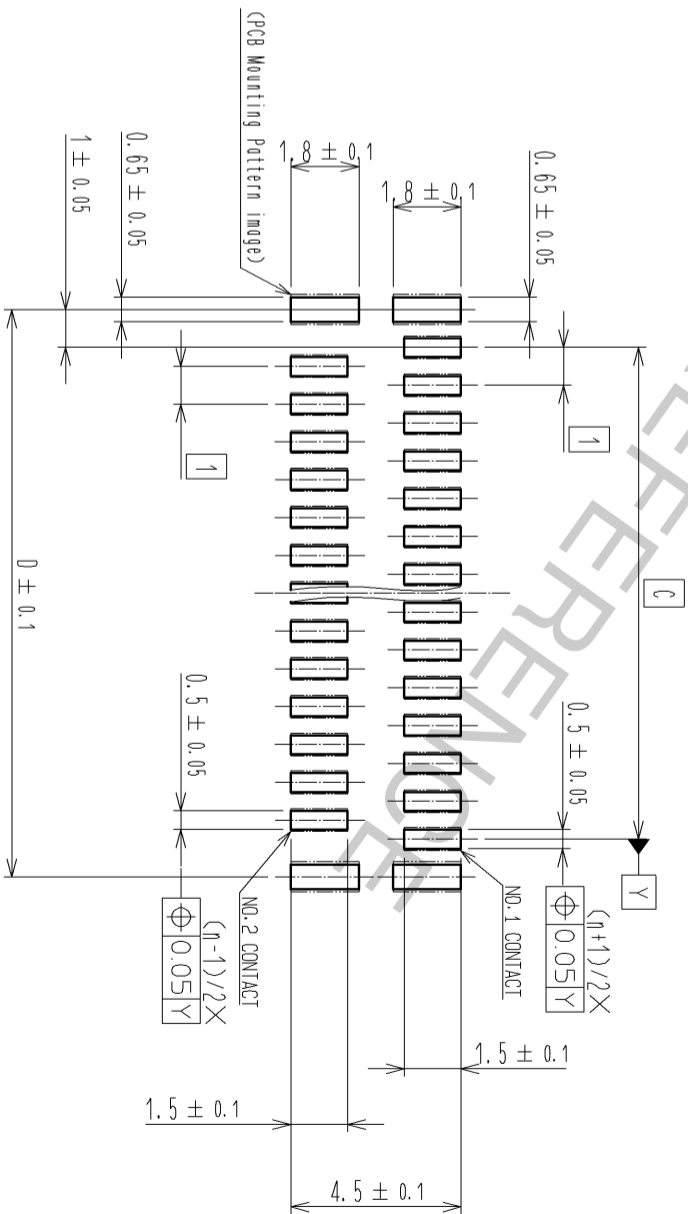

FORM HC0011-5-8

2

3

4

5

6

7

8

<b>HRS</b>	DRAWING NO.	EDC3-159266-03
	PART NO.	FH12-**-S-0.5SVA(54)
	CODE	CL586
	NO.	2/5

RECOMMENDED FPC/FFC (15:1)

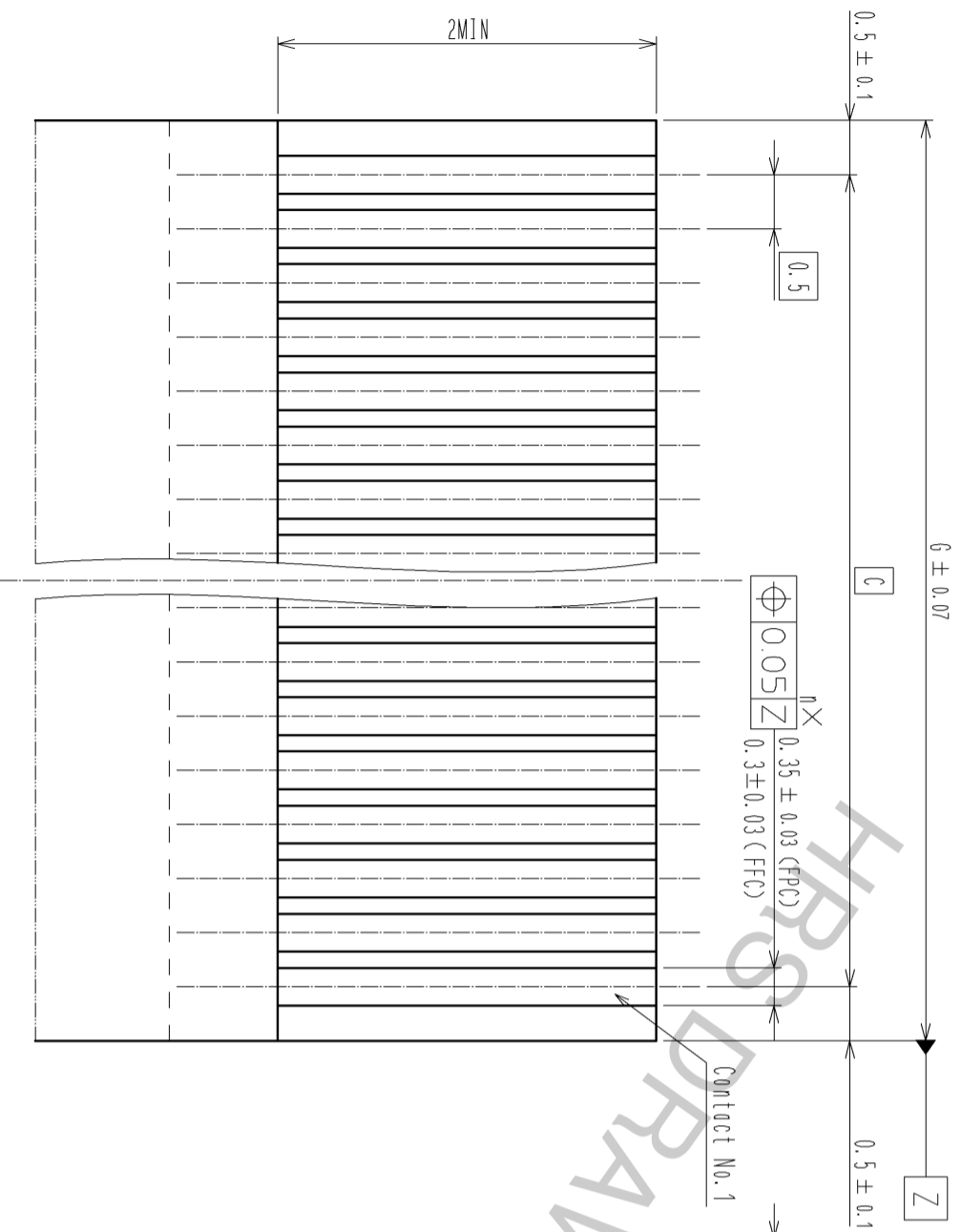

FPC CONFIGURATION (REFERENCE EXAMPLE) (SCALE:FREE)

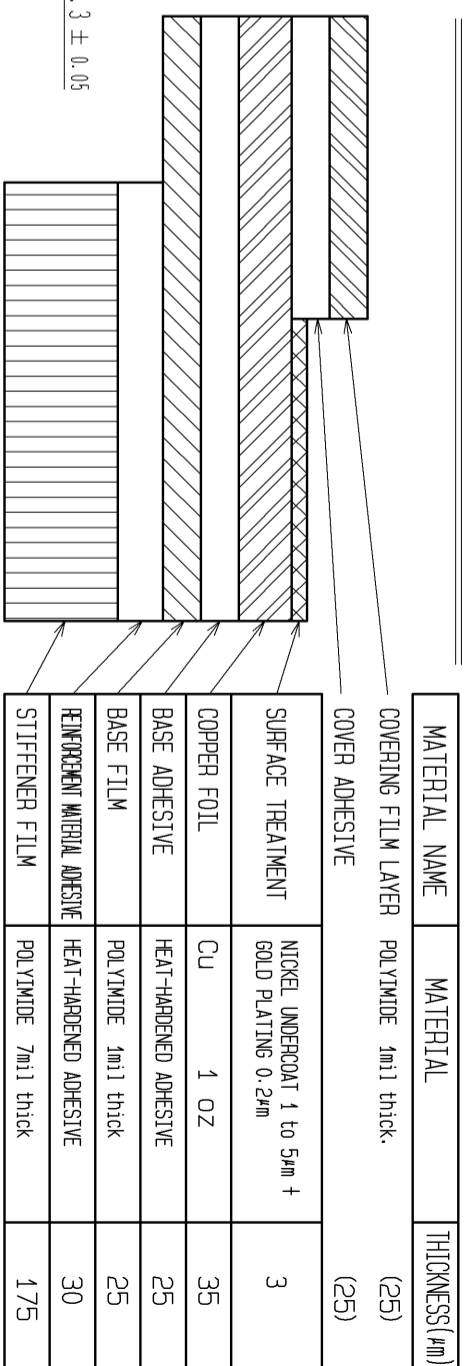

FFC CONFIGURATION (REFERENCE EXAMPLE) (SCALE:FREE)

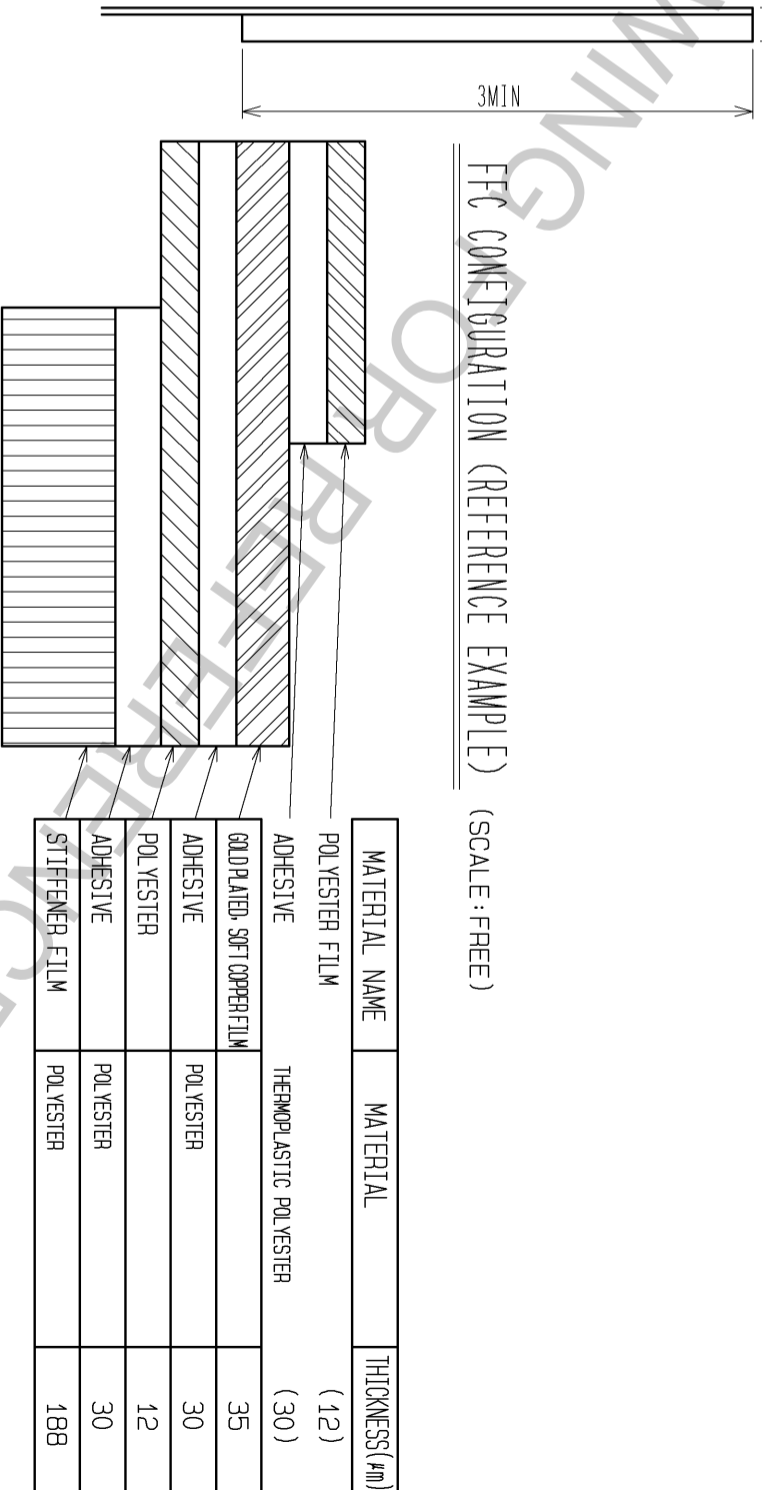

7 THICKNESS OF SUPPORTING TAPE SHALL BE 0.188(7.5MIL) MIN.

EMBOSSED CARRIER TAPE DIMENSION (2:1)

TAPE WIDTH : 32mm MIN

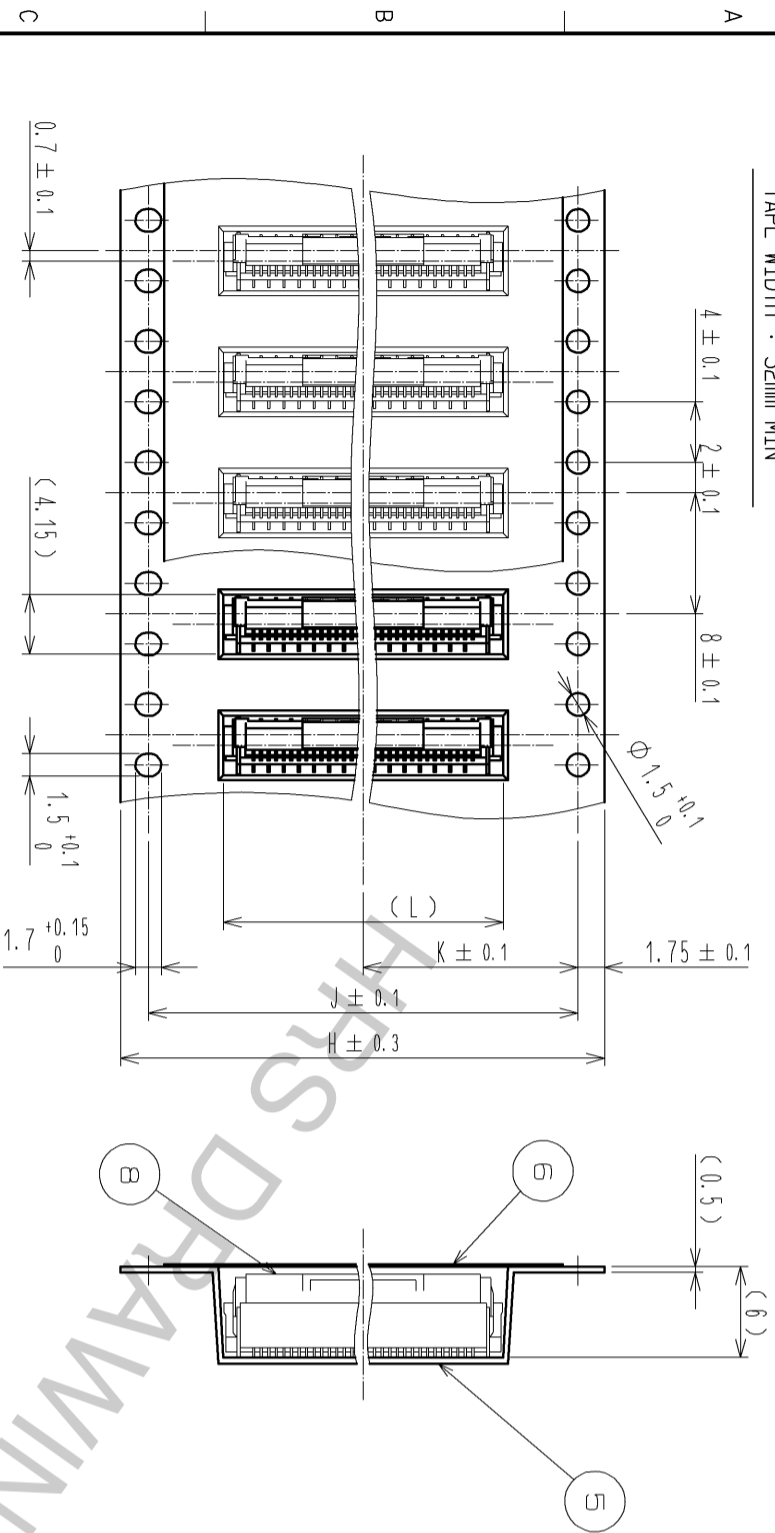

REEL DIMENSION(SHOW AS BELOW)(FREE)

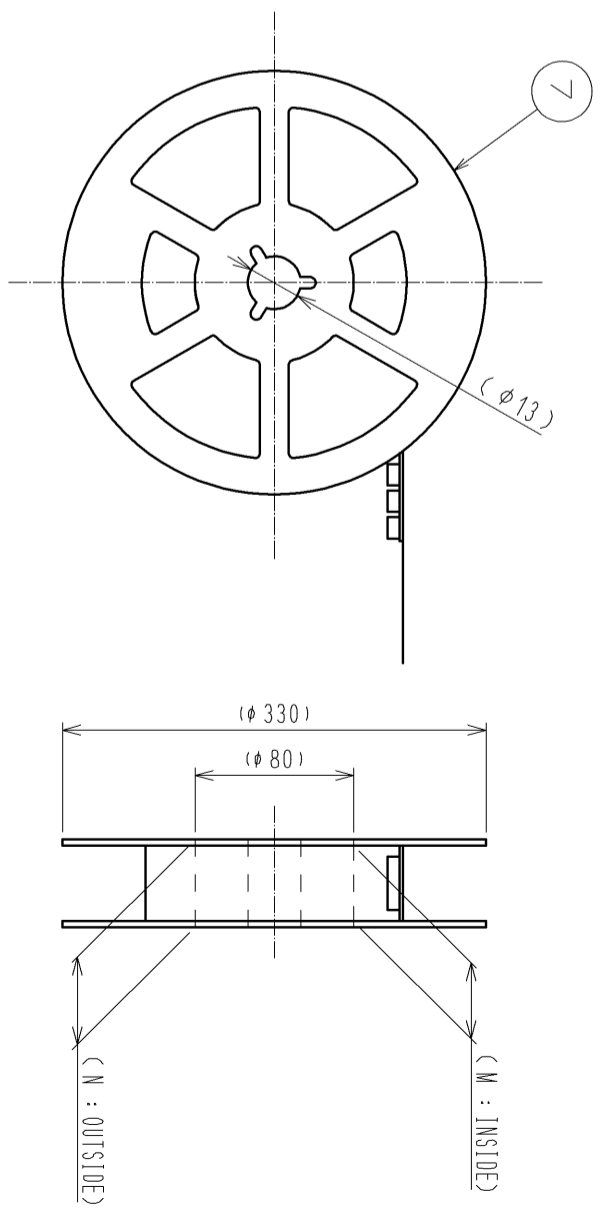

TAPE WIDTH : 24mm MAX

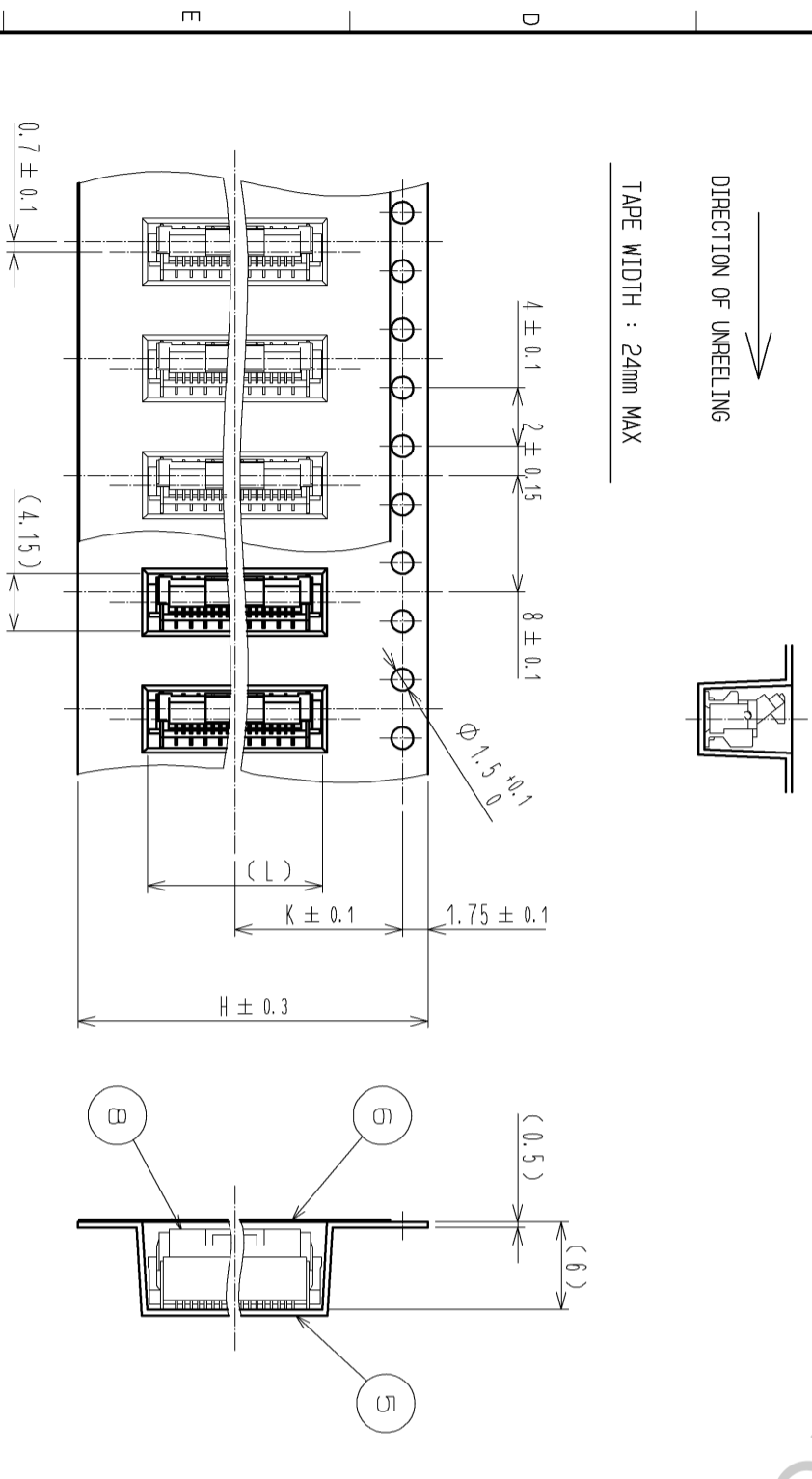

NOTE 8 REEL : 1000 CONNECTORS.

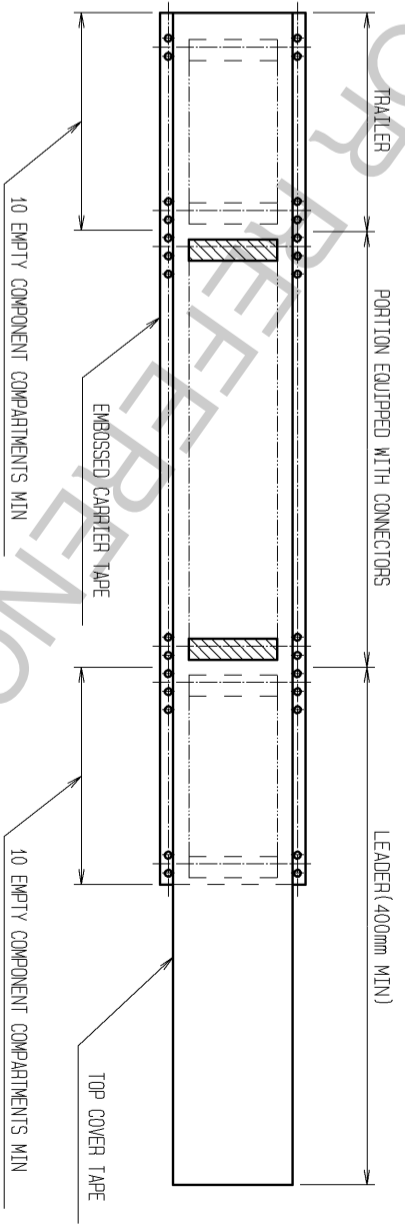

DIRECTION OF UNREELING

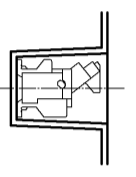

DRAWING FOR PACKING

<b>HRS</b>	
DRAWING NO.	EDC3-159266-03
PART NO.	FH12-**-S-0.5SVA(54)
CODE NO.	CL586
4/5	

PART NO.	CODE NO.	NUMBER OF CONTACTS	DIMENSION TABLE OF CONNECTOR, FCC, FCC, PCB MOUNTING PATTERN AND STENCIL PATTERN														DIMENSION TABLE OF DRAWING FOR PACKING						
			A	B	C	D	E	F	G	H	J	K	L	M	N								
FH12-6S-0.5SVA(54)	CL586-0756-4-54	6	6.4	4.9	2.5	4.5	6.2	2	3.5	16	—	7.5	6.5	17.4	21.4								
FH12-10S-0.5SVA(54)	CL586-0806-0-54	10	8.4	6.9	4.5	6.5	8.2	4	5.5	16	—	7.5	8.5	17.4	21.4								
FH12-12S-0.5SVA(54)	CL586-0757-7-54	12	9.4	7.9	5.5	7.5	9.2	4	6.5	16	—	7.5	9.5	17.4	21.4								
FH12-13S-0.5SVA(54)	CL586-0807-3-54	13	9.9	8.4	6	8	9.7	4	7	24	—	11.5	10	25.4	29.4								
FH12-15S-0.5SVA(54)	CL586-0808-6-54	15	10.9	9.4	7	9	10.7	4	8	24	—	11.5	11	25.4	29.4								
FH12-16S-0.5SVA(54)	CL586-0809-9-54	16	11.4	9.9	7.5	9.5	11.2	4	8.5	24	—	11.5	11.5	25.4	29.4								
FH12-17S-0.5SVA(54)	CL586-0810-8-54	17	11.9	10.4	8	10	11.7	4	9	24	—	11.5	12	25.4	29.4								
FH12-18S-0.5SVA(54)	CL586-0811-0-54	18	12.4	10.9	8.5	10.5	12.2	4	9.5	24	—	11.5	12.5	25.4	29.4								
FH12-20S-0.5SVA(54)	CL586-0812-3-54	20	13.4	11.9	9.5	11.5	13.2	4	10.5	24	—	11.5	13.5	25.4	29.4								
FH12-22S-0.5SVA(54)	CL586-0813-6-54	22	14.4	12.9	10.5	12.5	14.2	8	11.5	24	—	11.5	14.5	25.4	29.4								
FH12-24S-0.5SVA(54)	CL586-0814-9-54	24	15.4	13.9	11.5	13.5	15.2	8	12.5	24	—	11.5	15.5	25.4	29.4								
FH12-26S-0.5SVA(54)	CL586-0815-1-54	26	16.4	14.9	12.5	14.5	16.2	8	13.5	24	—	11.5	16.5	25.4	29.4								
FH12-30S-0.5SVA(54)	CL586-0750-8-54	30	18.4	16.9	14.5	16.5	18.2	8	15.5	32	28.4	14.2	18.5	33.4	37.4								
FH12-32S-0.5SVA(54)	CL586-0816-4-54	32	19.4	17.9	15.5	17.5	19.2	8	16.5	32	28.4	14.2	19.5	33.4	37.4								
FH12-33S-0.5SVA(54)	CL586-0818-0-54	33	19.9	18.4	16	18	19.7	8	17	32	28.4	14.2	20	33.4	37.4								
FH12-34S-0.5SVA(54)	CL586-0817-7-54	34	20.4	18.9	16.5	18.5	20.2	8	17.5	44	40.4	20.2	20.5	45.4	49.4								
FH12-36S-0.5SVA(54)	CL586-0819-2-54	36	21.4	19.9	17.5	19.5	21.2	8	18.5	44	40.4	20.2	21.5	45.4	49.4								
FH12-40S-0.5SVA(54)	CL586-0804-5-54	40	23.4	21.9	19.5	21.5	23.2	8	20.5	44	40.4	20.2	23.5	45.4	49.4								
FH12-45S-0.5SVA(54)	CL586-0820-1-54	45	25.9	24.4	22	24	25.7	8	23	44	40.4	20.2	26	45.4	49.4								
FH12-49S-0.5SVA(54)	CL586-0821-4-54	49	27.9	26.4	24	26	27.7	8	25	44	40.4	20.2	28	45.4	49.4								
FH12-50S-0.5SVA(54)	CL586-0805-8-54	50	28.4	26.9	24.5	26.5	28.2	8	25.5	44	40.4	20.2	28.5	45.4	49.4								
FH12-60S-0.5SVA(54)	CL586-0749-9-54	60	33.4	31.9	29.5	31.5	33.2	8	30.5	56	52.4	26.2	33.5	57.4	61.4								

FORM HC0011-5-8

2

3

4

5

6

7

8

<b>HR5</b>	DRAWING NO.	EDC3-159266-03
	PART NO.	FH12-**-S-0.5SVA(54)
	CODE	CL586

5/5