



Chipsmall Limited consists of a professional team with an average of over 10 year of expertise in the distribution of electronic components. Based in Hongkong, we have already established firm and mutual-benefit business relationships with customers from,Europe,America and south Asia,supplying obsolete and hard-to-find components to meet their specific needs.

With the principle of “Quality Parts,Customers Priority,Honest Operation,and Considerate Service”,our business mainly focus on the distribution of electronic components. Line cards we deal with include Microchip,ALPS,ROHM,Xilinx,Pulse,ON,Everlight and Freescale. Main products comprise IC,Modules,Potentiometer,IC Socket,Relay,Connector.Our parts cover such applications as commercial,industrial, and automotives areas.

We are looking forward to setting up business relationship with you and hope to provide you with the best service and solution. Let us make a better world for our industry!



Contact us

Tel: +86-755-8981 8866 Fax: +86-755-8427 6832

Email & Skype: info@chipsmall.com Web: www.chipsmall.com

Address: A1208, Overseas Decoration Building, #122 Zhenhua RD., Futian, Shenzhen, China



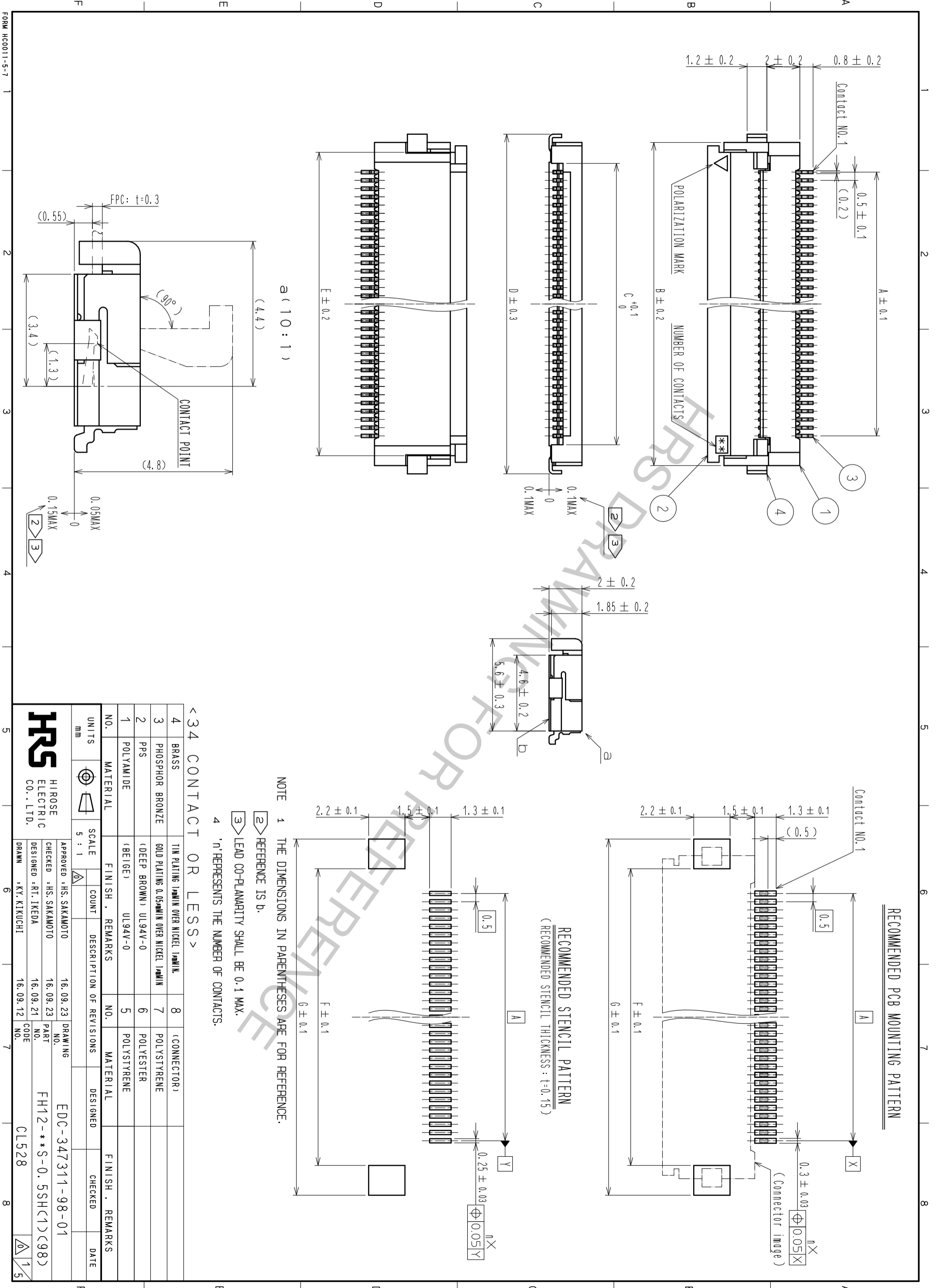

RECOMMENDED PCB MOUNTING PATTERN

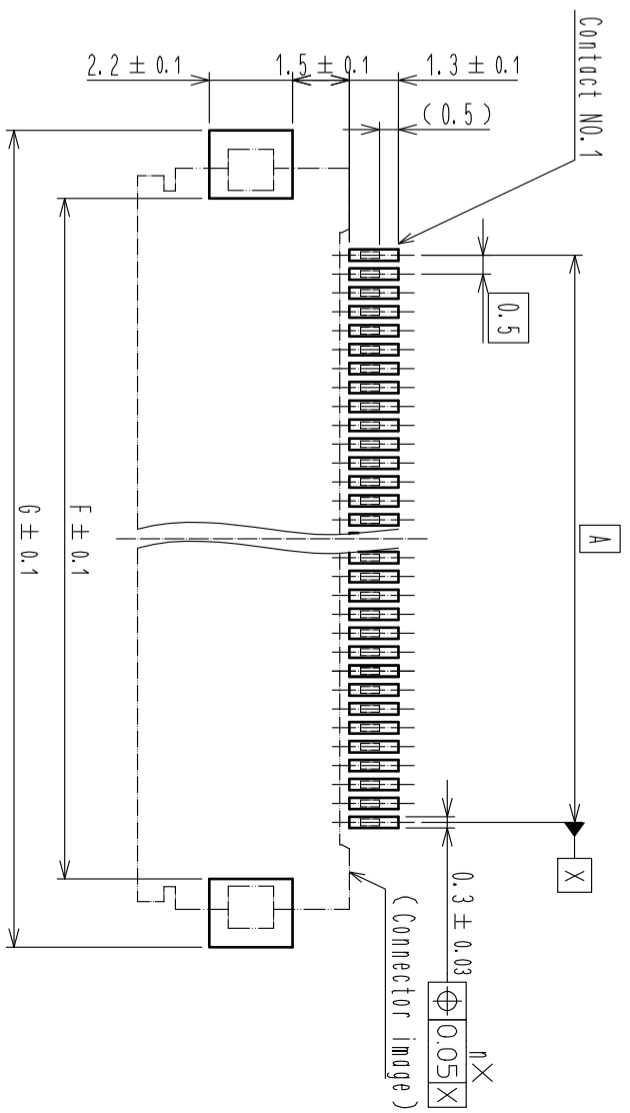

RECOMMENDED STENCIL PATTERN
(RECOMMENDED STENCIL THICKNESS : 1-0.15)

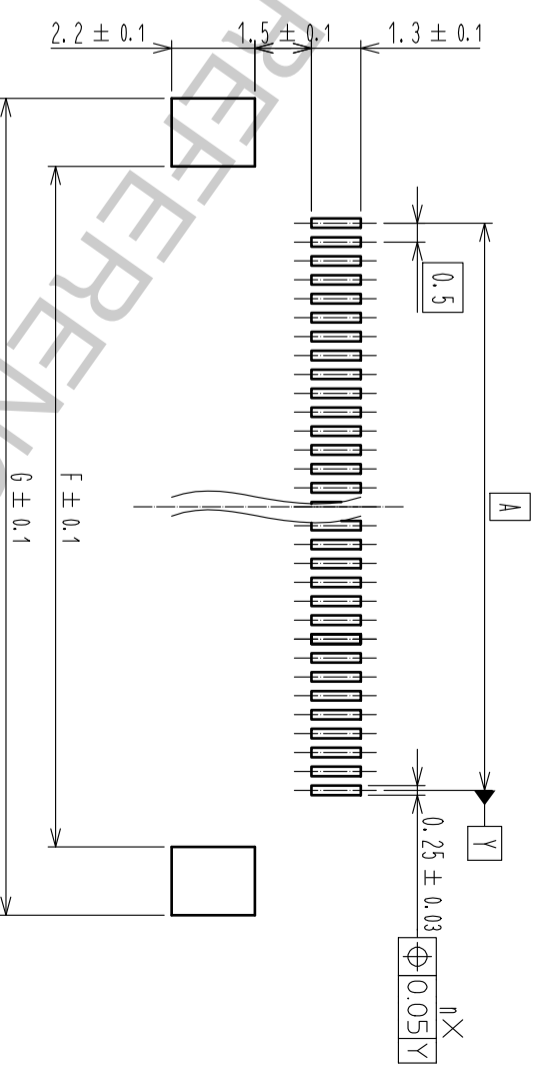

NOTE 1 THE DIMENSIONS IN PARENTHESES ARE FOR REFERENCE.
 2 REFERENCE IS b.
 3 LEAD CO-PLANARITY SHALL BE 0.1 MAX.
 4 'n' REPRESENTS THE NUMBER OF CONTACTS.

< 34 CONTACT OR LESS >

4	BRASS	TIN PLATING 1μMIN OVER NICKEL 1μMIN.	8	(CONNECTOR)	
3	PHOSPHOR BRONZE	GOLD PLATING 0.05μMIN OVER NICKEL 1μMIN	7	POLYSTYRENE	
2	PPS	(DEEP BROWN) UL94V-0	6	POLYESTER	
1	POLYAMIDE	(BEIGE) UL94V-0	5	POLYSTYRENE	
NO.	MATERIAL	FINISH . REMARKS	NO.	MATERIAL	FINISH . REMARKS
UNITS	SCALE	COUNT	DESCRIPTION OF REVISIONS	DESIGNED	CHECKED
mm	5 : 1				

<p>HIROSE ELECTRIC CO., LTD.</p>	Approved : HS. SAKAMOTO Checked : HS. SAKAMOTO Designed : RT. IKEDA Drawn : KY. KIKUCHI	16.09.23 16.09.23 16.09.21 16.09.12	DRAWING NO. PART NO. CODE NO.	EDC-347311-98-01 FH12-**-S-0.5SH(1)(98) CL528
----------------------------------	--	--	-------------------------------------	---

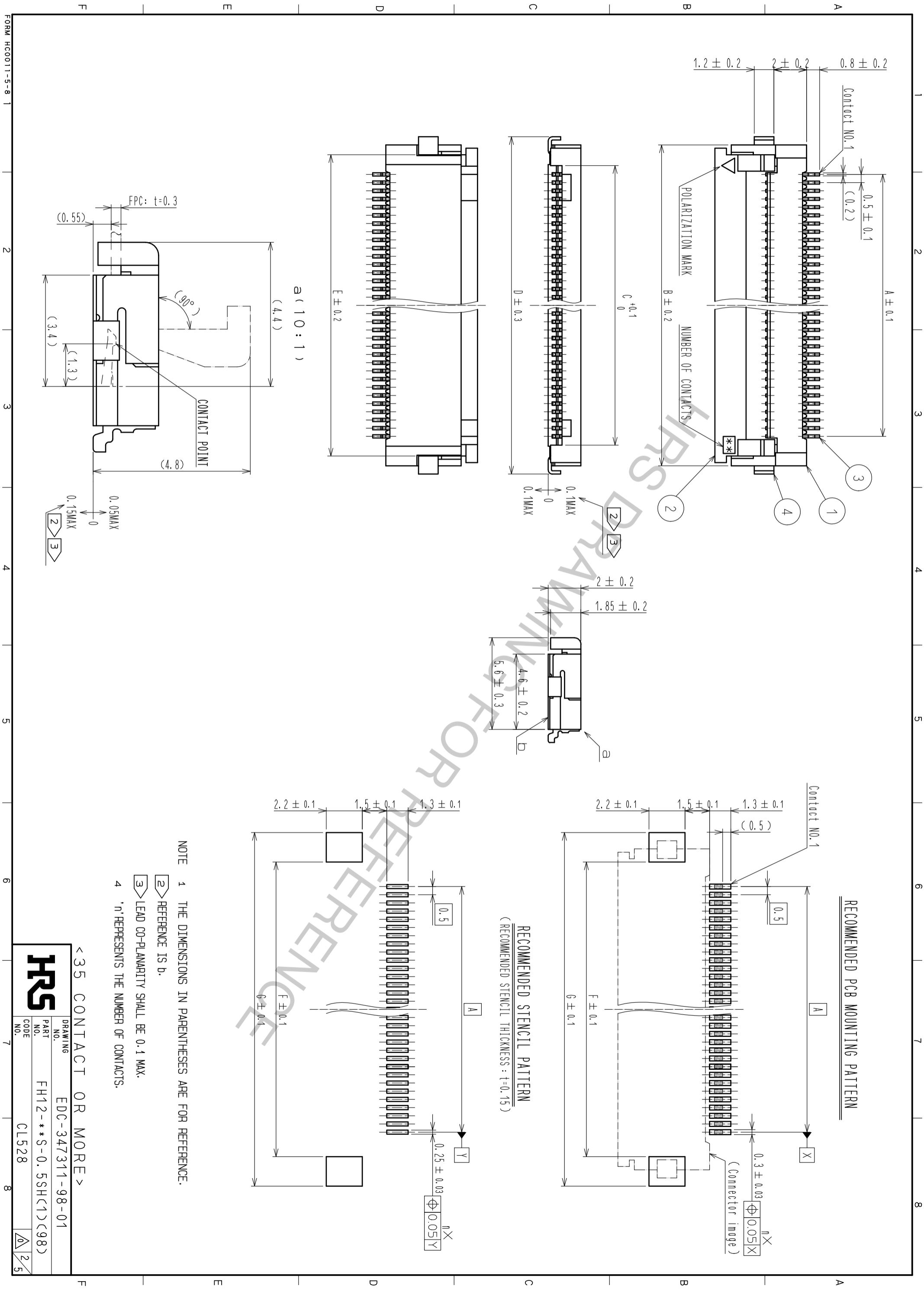

FORM HC0011-5-8

< 35 CONTACT OR MORE >

DRAWING NO.	EDC-347311-98-01
PART NO.	FH12-**-S-0.5SH(1)(98)
CODE	CL528

HRS

NO. 2/5

NOTE 1 THE DIMENSIONS IN PARENTHESES ARE FOR REFERENCE.
 2 REFERENCE IS b.
 3 LEAD CO-PLANARITY SHALL BE 0.1 MAX.
 4 'n' REPRESENTS THE NUMBER OF CONTACTS.

RECOMMENDED STENCIL PATTERN
 (RECOMMENDED STENCIL THICKNESS : t=0.15)

RECOMMENDED PCB MOUNTING PATTERN

RECOMMENDED FPC/FFC (15:1)

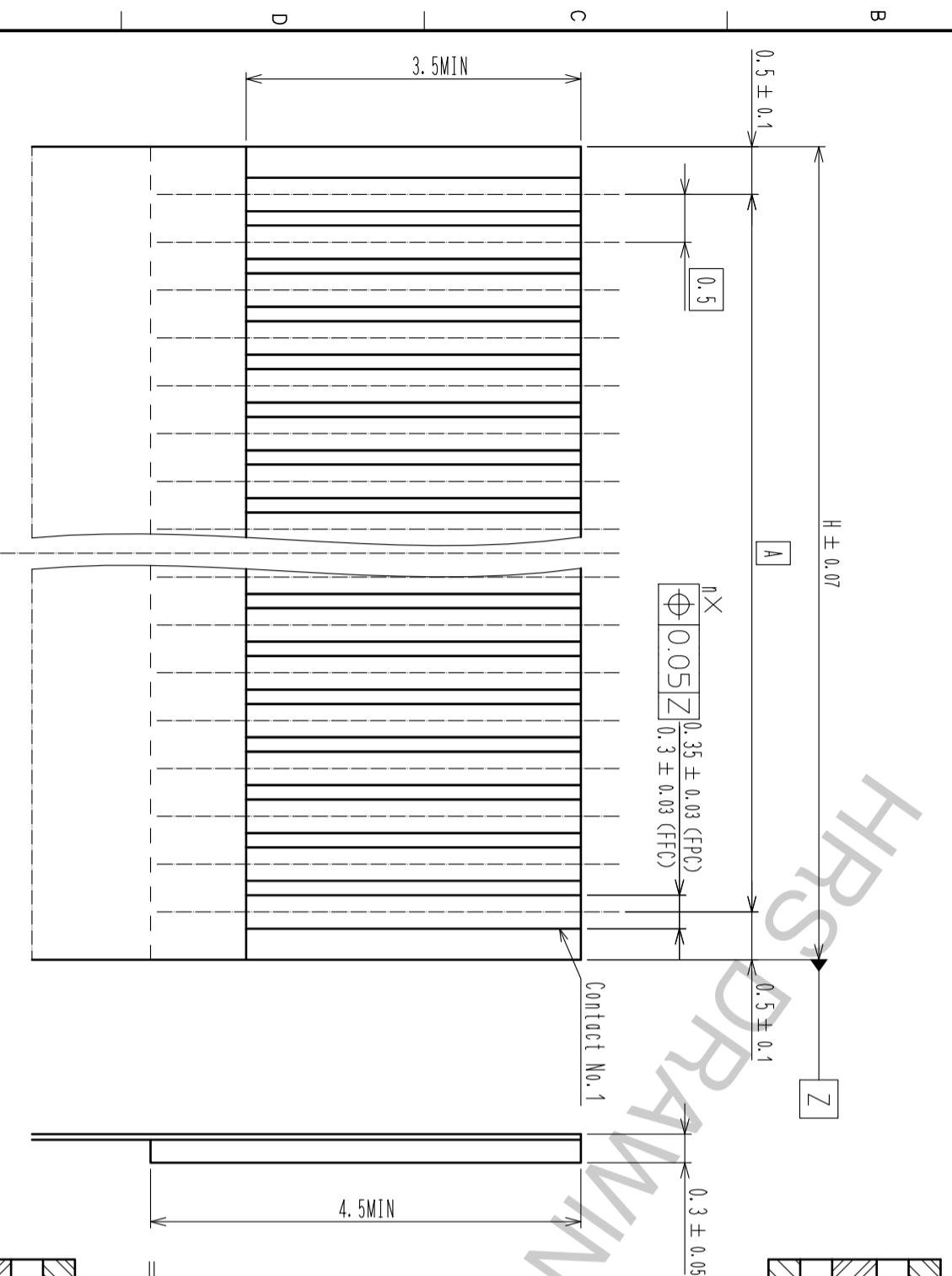

FPC CONFIGURATION (REFERENCE EXAMPLE)

(SCALE: FREE)

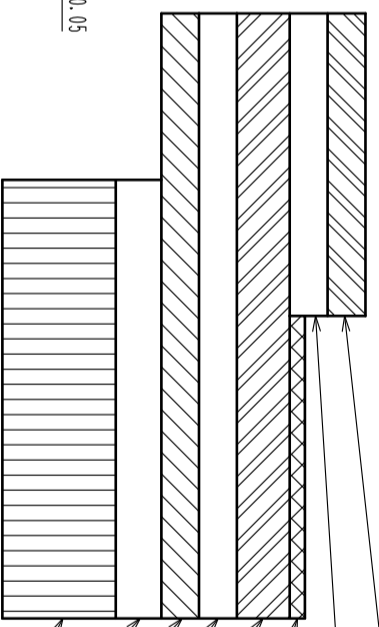

MATERIAL NAME	MATERIAL	THICKNESS(μm)
COVERING FILM LAYER	POLYIMIDE 1m11 thick.	(25)
COVER ADHESIVE		(25)
SURFACE TREATMENT	NICKEL UNDERCOAT 1 to 5μm + GOLD PLATING 0.2μm	3
COPPER FOIL	CU 1 OZ	35
BASE ADHESIVE	HEAT-HARDENED ADHESIVE	25
BASE FILM	POLYIMIDE 1m11 thick	25
REINFORCEMENT MATERIAL ADHESIVE	HEAT-HARDENED ADHESIVE	30
STIFFENER FILM	POLYIMIDE 7m11 thick	175

FFC CONFIGURATION (REFERENCE EXAMPLE)

(SCALE: FREE)

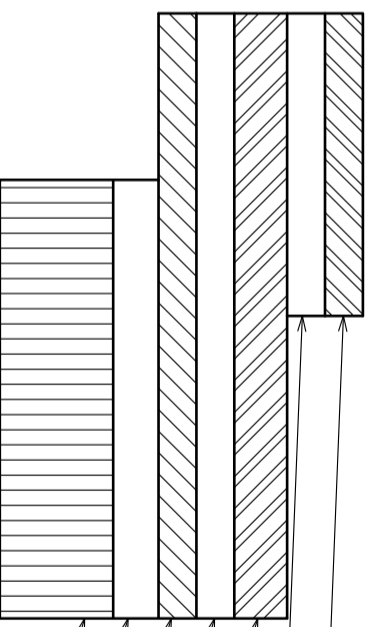

MATERIAL NAME	MATERIAL	THICKNESS(μm)
POLYESTER FILM	THERMOPLASTIC POLYESTER	(12)
ADHESIVE		(30)
GOLD PLATED SOFT COPPER FILM		35
ADHESIVE	POLYESTER	30
POLYESTER		12
ADHESIVE	POLYESTER	30
STIFFENER FILM	POLYESTER	188

HRS

DRAWING NO.	EDC-347311-98-01
PART NO.	FH12-**-S-0.5SH(1)(98)
CODE	CL528

TAPE WIDTH: 32mm MIN

EMBOSSED CARRIER TAPE DIMENSION(2:1)

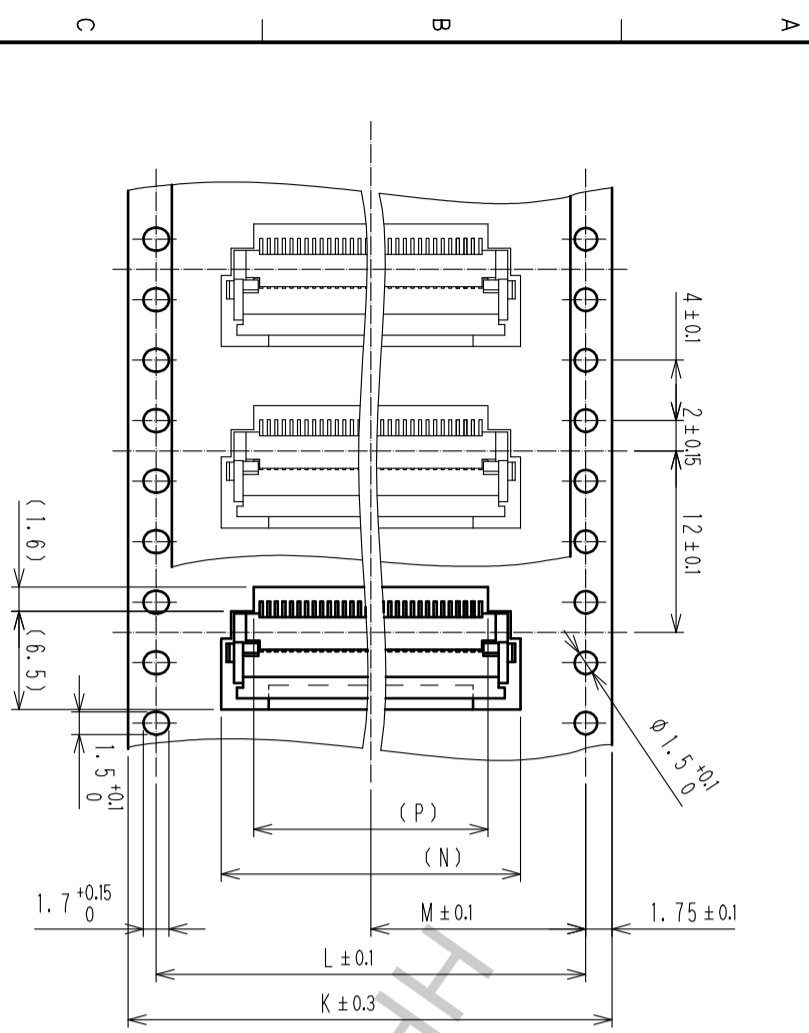

DIRECTION OF UNREELING

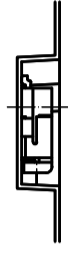

TAPE WIDTH: 24mm MAX

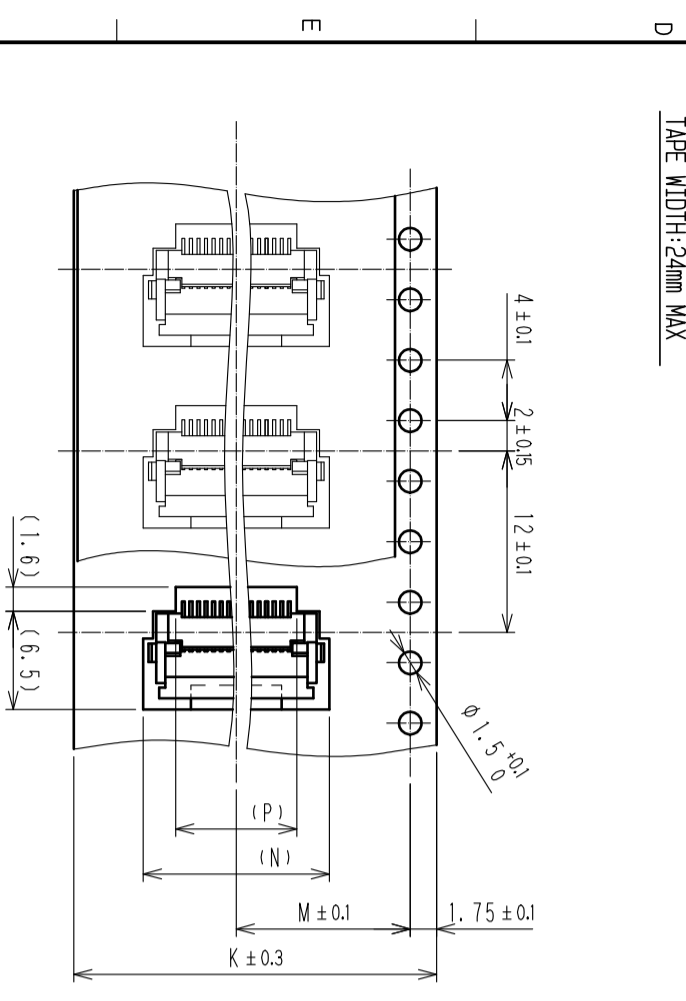

DIRECTION OF UNREELING

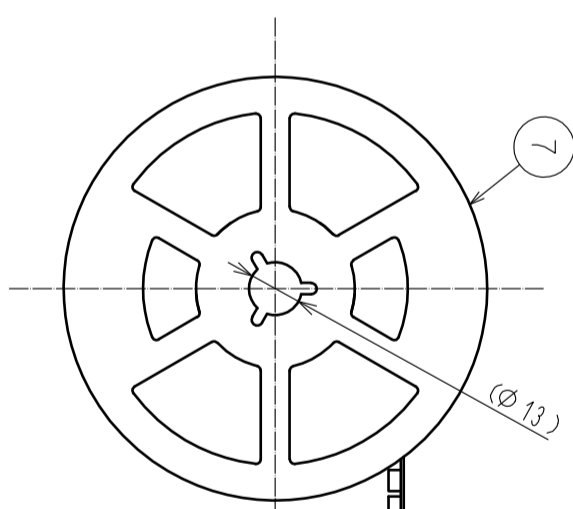
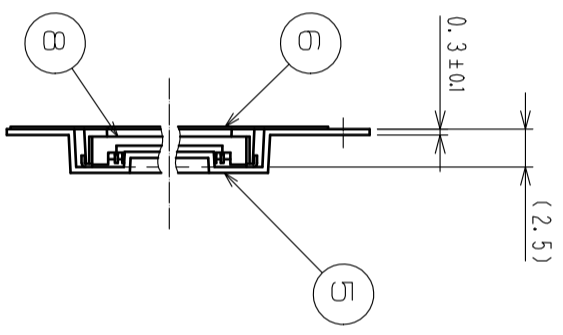
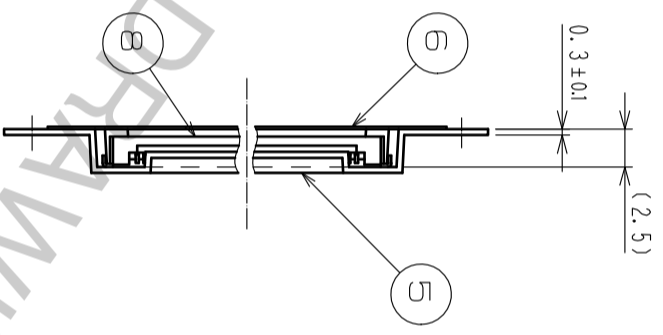
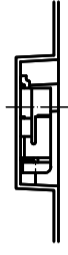

REEL DIMENSION (FREE)

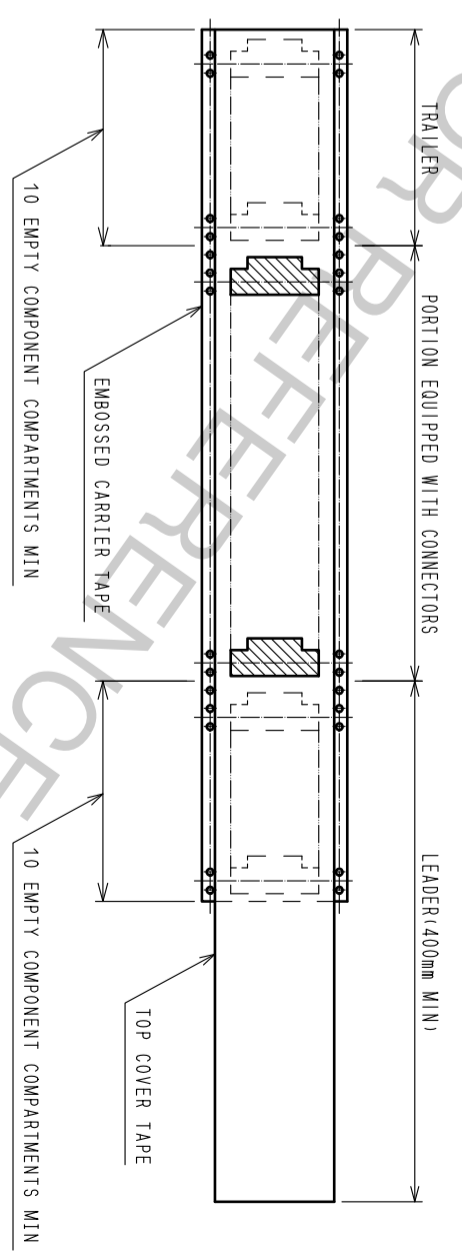
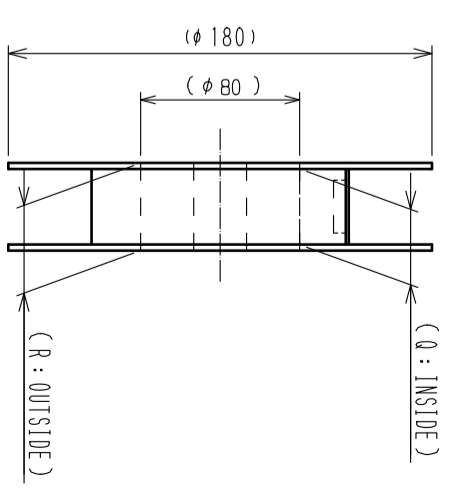

- 5 PER REEL: 500 CONNECTORS.
- 6 SEE DIMENSION TABLE IN THE APPENDIX.

<DRAWING FOR PACKING>

HRS	
DRAWING NO.	EDC-347311-98-01
PART NO.	FH12-**-S-0.5SH(1)(98)
CODE	CL528
NO.	4/5

FORM HC0011-5-8 1 2 3 4 5 6 7 8

PART NO.	CODE NO.	NUMBER OF CONTACT	DIMENSION TABLE OF CONNECTOR-PGC-FPC-PCB MOUNTING PATTERN AND STENCIL PATTERN																DIMENSION TABLE OF DRAWING FOR PACKING							
			A	B	C	D	E	F	G	H	K	L	M	N	P	Q	R									
FH12-6S-0.5SH(1)(98)	CL528-0001-0-98	6	2.5	6.1	3.57	7.1	4.9	4.5	8.1	3.5	16	—	7.5	7.8	3.5	17.4	21.4									
FH12-8S-0.5SH(1)(98)	CL528-0002-2-98	8	3.5	7.1	4.57	8.1	5.9	5.5	9.1	4.5	16	—	7.5	8.8	4.5	17.4	21.4									
FH12-10S-0.5SH(1)(98)	CL528-0003-5-98	10	4.5	8.1	5.57	9.1	6.9	6.5	10.1	5.5	16	—	7.5	9.8	5.5	17.4	21.4									
FH12-11S-0.5SH(1)(98)	CL528-0004-8-98	11	5	8.6	6.07	9.6	7.4	7	10.6	6	16	—	7.5	10.3	6	17.4	21.4									
FH12-12S-0.5SH(1)(98)	CL528-0005-0-98	12	5.5	9.1	6.57	10.1	7.9	7.5	11.1	6.5	24	—	11.5	10.8	6.5	25.4	29.4									
FH12-13S-0.5SH(1)(98)	CL528-0006-3-98	13	6	9.6	7.07	10.6	8.4	8	11.6	7	24	—	11.5	11.3	7	25.4	29.4									
FH12-14S-0.5SH(1)(98)	CL528-0007-6-98	14	6.5	10.1	7.57	11.1	8.9	8.5	12.1	7.5	24	—	11.5	11.8	7.5	25.4	29.4									
FH12-15S-0.5SH(1)(98)	CL528-0008-9-98	15	7	10.6	8.07	11.6	9.4	9	12.6	8	24	—	11.5	12.3	8	25.4	29.4									
FH12-16S-0.5SH(1)(98)	CL528-0009-1-98	16	7.5	11.1	8.57	12.1	9.9	9.5	13.1	8.5	24	—	11.5	12.8	8.5	25.4	29.4									
FH12-17S-0.5SH(1)(98)	CL528-0010-0-98	17	8	11.6	9.07	12.6	10.4	10	13.6	9	24	—	11.5	13.3	9	25.4	29.4									
FH12-18S-0.5SH(1)(98)	CL528-0011-3-98	18	8.5	12.1	9.57	13.1	10.9	10.5	14.1	9.5	24	—	11.5	13.8	9.5	25.4	29.4									
FH12-19S-0.5SH(1)(98)	CL528-0012-6-98	19	9	12.6	10.07	13.6	11.4	11	14.6	10	24	—	11.5	14.3	10	25.4	29.4									
FH12-20S-0.5SH(1)(98)	CL528-0013-9-98	20	9.5	13.1	10.57	14.1	11.9	11.5	15.1	10.5	24	—	11.5	14.8	10.5	25.4	29.4									
FH12-22S-0.5SH(1)(98)	CL528-0014-1-98	22	10.5	14.1	11.57	15.1	12.9	12.5	16.1	11.5	24	—	11.5	15.8	11.5	25.4	29.4									
FH12-24S-0.5SH(1)(98)	CL528-0015-4-98	24	11.5	15.1	12.57	16.1	13.9	13.5	17.1	12.5	24	—	11.5	16.8	12.5	25.4	29.4									
FH12-25S-0.5SH(1)(98)	CL528-0016-7-98	25	12	15.6	13.07	16.6	14.4	14	17.6	13	24	—	11.5	17.3	13	25.4	29.4									
FH12-26S-0.5SH(1)(98)	CL528-0017-0-98	26	12.5	16.1	13.57	17.1	14.9	14.5	18.1	13.5	24	—	11.5	17.8	13.5	25.4	29.4									
FH12-28S-0.5SH(1)(98)	CL528-0018-2-98	28	13.5	17.1	14.57	18.1	15.9	15.5	19.1	14.5	32	28.4	14.2	18.8	14.5	33.4	37.4									
FH12-30S-0.5SH(1)(98)	CL528-0019-5-98	30	14.5	18.1	15.57	19.1	16.9	16.5	20.1	15.5	32	28.4	14.2	19.8	15.5	33.4	37.4									
FH12-32S-0.5SH(1)(98)	CL528-0020-4-98	32	15.5	19.1	16.57	20.1	17.9	17.5	21.1	16.5	32	28.4	14.2	20.8	16.5	33.4	37.4									
FH12-33S-0.5SH(1)(98)	CL528-0021-7-98	33	16	19.6	17.07	20.6	18.4	18	21.6	17	32	28.4	14.2	21.3	17	33.4	37.4									
FH12-34S-0.5SH(1)(98)	CL528-0022-0-98	34	16.5	20.1	17.57	21.1	18.9	18.5	22.1	17.5	32	28.4	14.2	21.8	17.5	33.4	37.4									
FH12-35S-0.5SH(1)(98)	CL528-0023-2-98	35	17	20.6	18.07	21.6	19.4	19	22.6	18	44	40.4	20.2	22.3	18	45.4	49.4									
FH12-36S-0.5SH(1)(98)	CL528-0024-5-98	36	17.5	21.1	18.57	22.1	19.9	19.5	23.1	18.5	44	40.4	20.2	22.8	18.5	45.4	49.4									
FH12-40S-0.5SH(1)(98)	CL528-0025-8-98	40	19.5	23.1	20.57	24.1	21.9	21.5	25.1	20.5	44	40.4	20.2	24.8	20.5	45.4	49.4									
FH12-45S-0.5SH(1)(98)	CL528-0026-0-98	45	22	25.6	23.07	26.6	24.4	24	27.6	23	44	40.4	20.2	27.3	23	45.4	49.4									
FH12-50S-0.5SH(1)(98)	CL528-0027-3-98	50	24.5	28.1	25.57	29.1	26.9	26.5	30.1	25.5	44	40.4	20.2	29.8	25.5	45.4	49.4									
FH12-53S-0.5SH(1)(98)	CL528-0028-6-98	53	26	29.6	27.07	30.6	28.4	28	31.6	27	44	40.4	20.2	31.3	27	45.4	49.4									

HRS	
DRAWING NO.	EDC-347311-98-01
PART NO.	FH12-**-S-0.5SH(1)(98)
CODE	CL528

