



Chipsmall Limited consists of a professional team with an average of over 10 year of expertise in the distribution of electronic components. Based in Hongkong, we have already established firm and mutual-benefit business relationships with customers from,Europe,America and south Asia,supplying obsolete and hard-to-find components to meet their specific needs.

With the principle of “Quality Parts,Customers Priority,Honest Operation,and Considerate Service”,our business mainly focus on the distribution of electronic components. Line cards we deal with include Microchip,ALPS,ROHM,Xilinx,Pulse,ON,Everlight and Freescale. Main products comprise IC,Modules,Potentiometer,IC Socket,Relay,Connector.Our parts cover such applications as commercial,industrial, and automotives areas.

We are looking forward to setting up business relationship with you and hope to provide you with the best service and solution. Let us make a better world for our industry!



Contact us

Tel: +86-755-8981 8866 Fax: +86-755-8427 6832

Email & Skype: info@chipsmall.com Web: www.chipsmall.com

Address: A1208, Overseas Decoration Building, #122 Zhenhua RD., Futian, Shenzhen, China



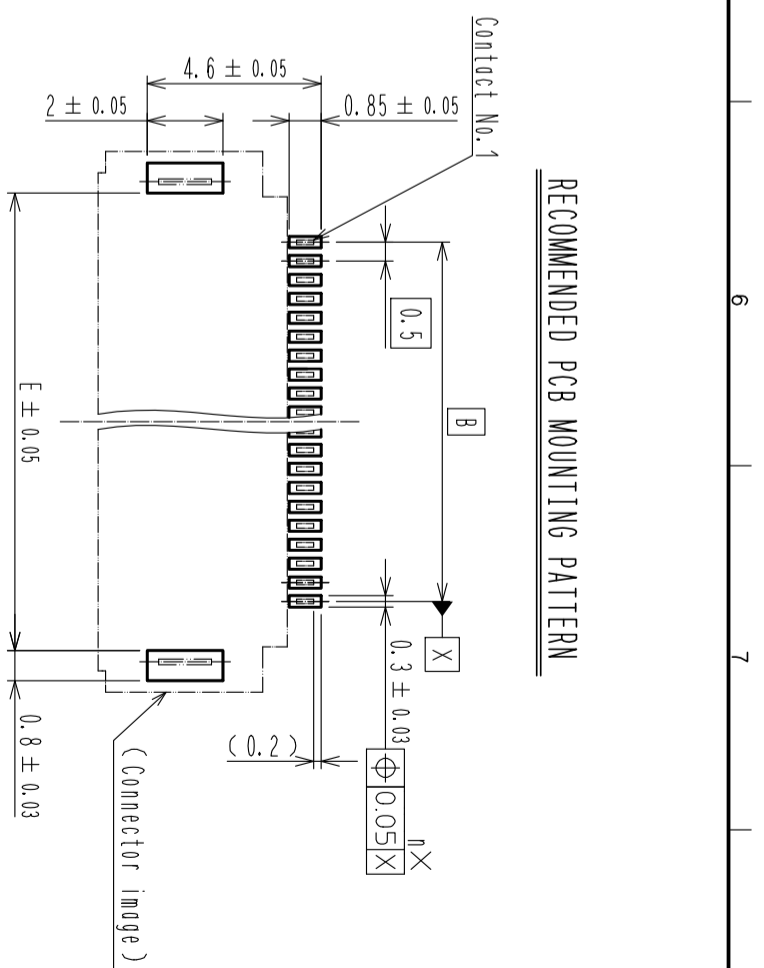
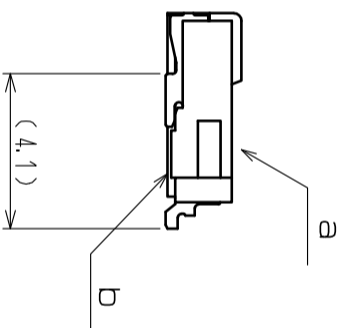
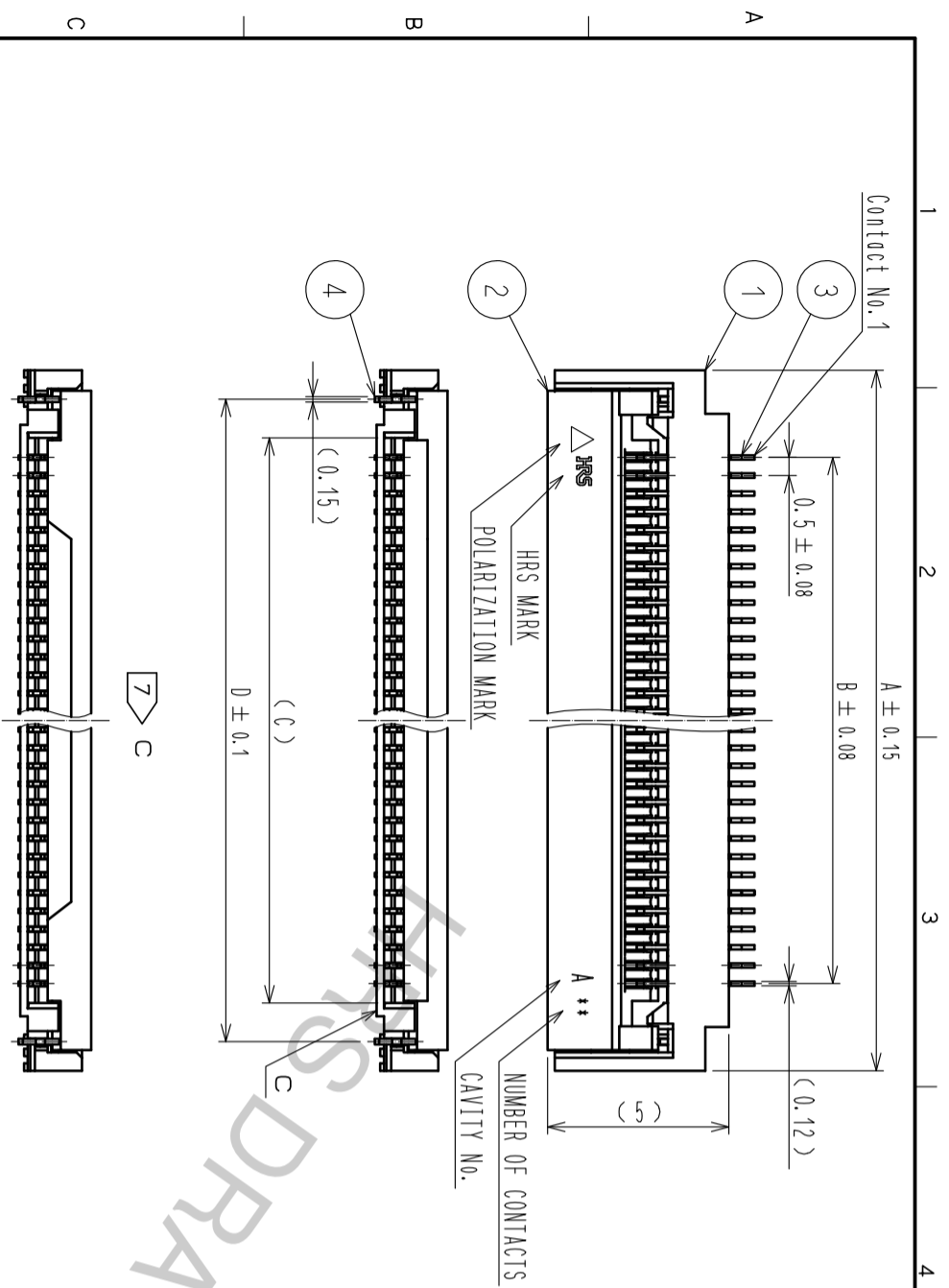

RECOMMENDED STENCIL PATTERN
(RECOMMENDED STENCIL THICKNESS : t=0.12)

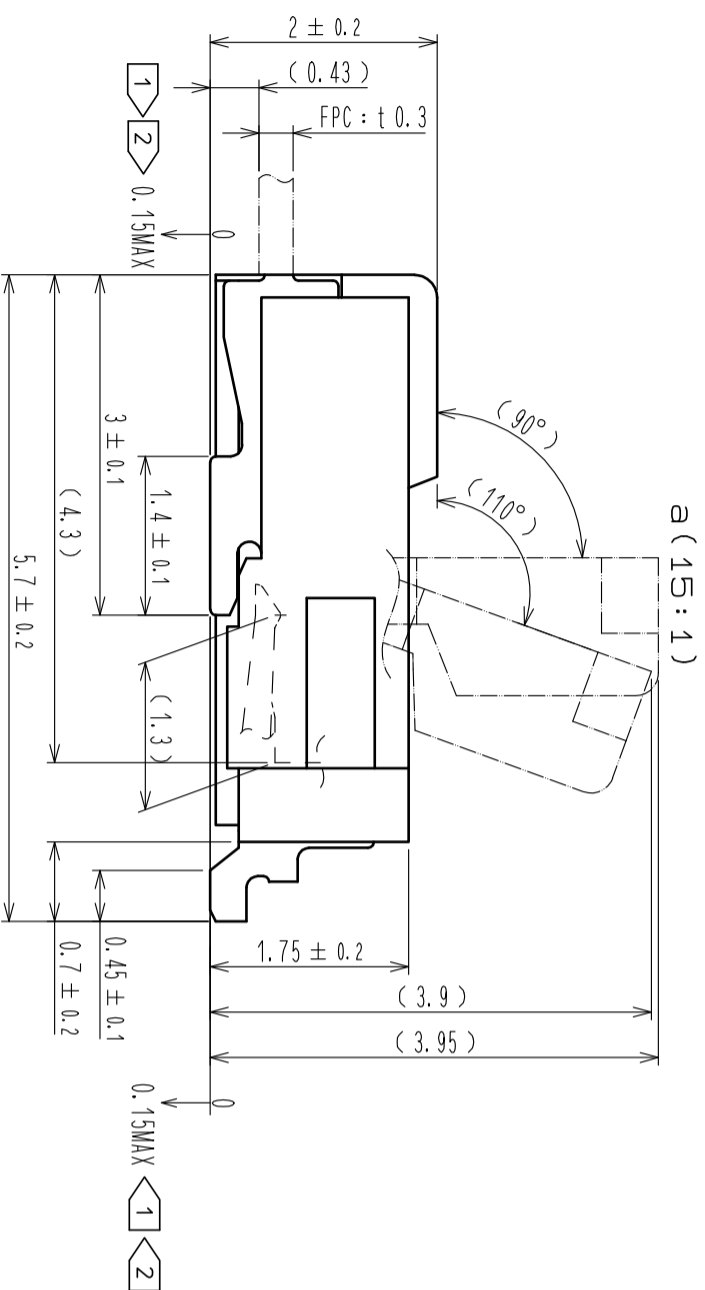
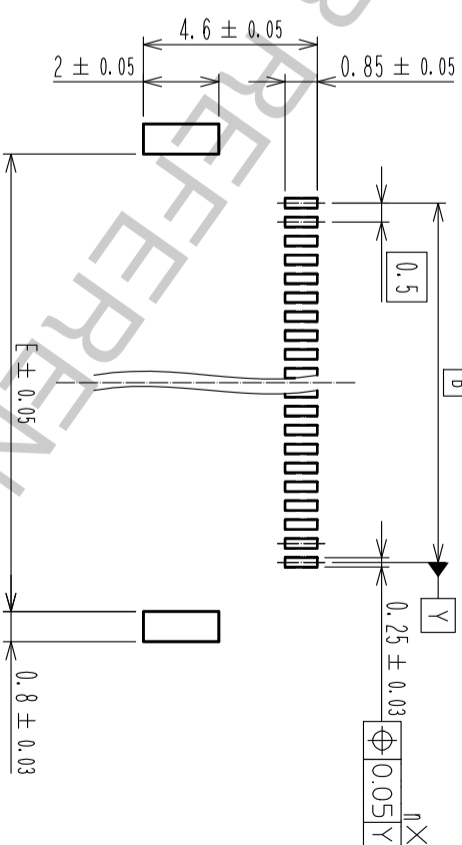

NOTES 1 Lead CO-PLANARITY including reinforced metal fittings shall be 0.1 MAX.

2 Dimension: from reference b.

3 To be delivered with tape and reel packages.

4 Note that preventive hole for sink mark could be added for improvement.

5 The quality remains good. Even with the dark spots, which could occasionally occur molded plastics.

6 This product satisfies halogen free requirements defined as 900ppm maximum chlorine, 900ppm maximum bromine, and 1500ppm maximum total of chlorine and bromine.

7 Shows actuator configuration of 60 pos.

8 'n' represents the number of contacts.

9 The dimension in parentheses are for reference.

4	BRASS (PLATED MATERIAL)	TIN PLATING (REFLOW FINISHED) 1μMIN OVER COPPER 0.3μMIN	8	(CONNECTOR)		
3	PHOSPHOR BRONZE	(CONTACT AREA-LEAD) GOLD 0.03μMIN OVER NICKEL NICKEL PLATING 1μMIN	7	POLYSTYRENE		
2	LCP	BLACK UL94V-0	6	POLYESTER		
1	LCP	GRAY UL94V-0	5	POLYSTYRENE		
MATERIAL		FINISH . REMARKS		NO.		MATERIAL
UNITS		SCALE	COUNT	DESCRIPTION OF REVISIONS		DESIGNED
mm		5 : 1	Δ			CHECKED
HRS		HI ROSE ELECTRIC CO., LTD.		APPROVED : HS. SAKAMOTO		DATE
				CHECKED : HS. SAKAMOTO		
				DESIGNED : HK. KINOUCHI		
				DRAWN : RK. OGASAWARA		
				NO. 16.09.23		EDC-328248-99-00
				PART NO. 16.09.23		FH52-**-S-0.5SH(99)
				CODE NO. 16.09.21		CL580

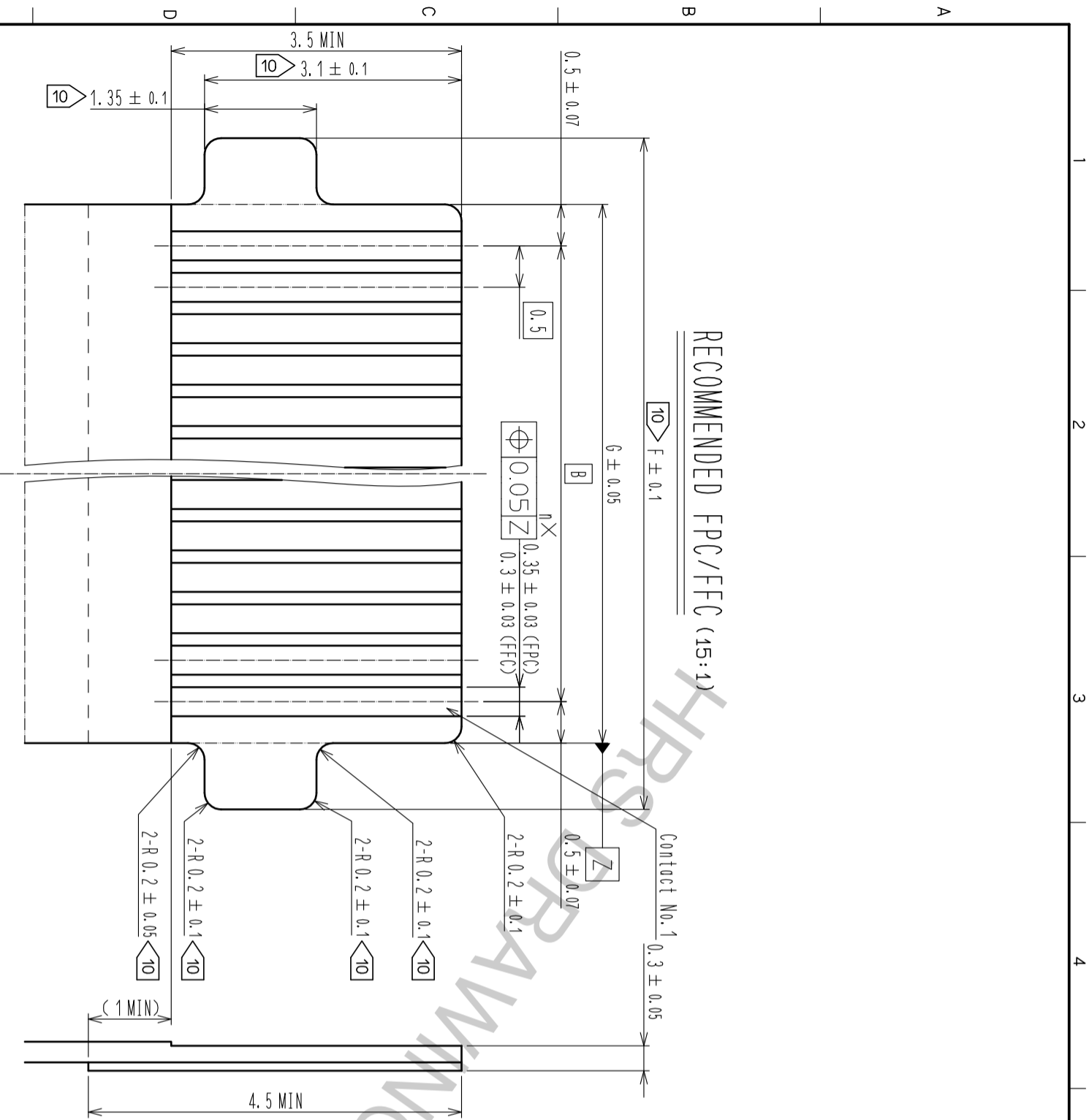

FPC CONFIGURATION (REFERENCE EXAMPLE)

(SCALE: FREE)

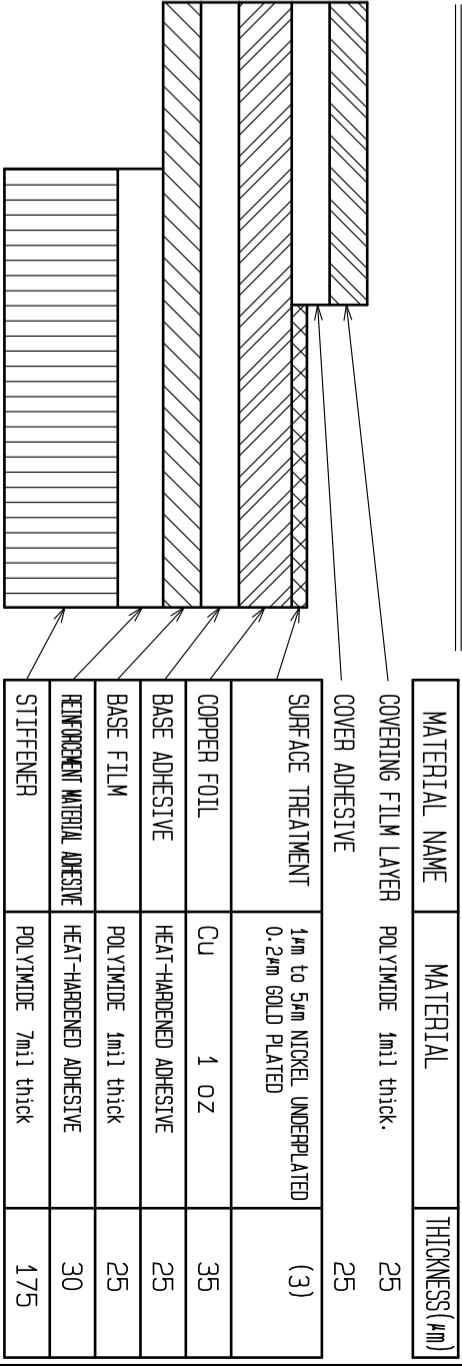

FFC CONFIGURATION (REFERENCE EXAMPLE)

(SCALE: FREE)

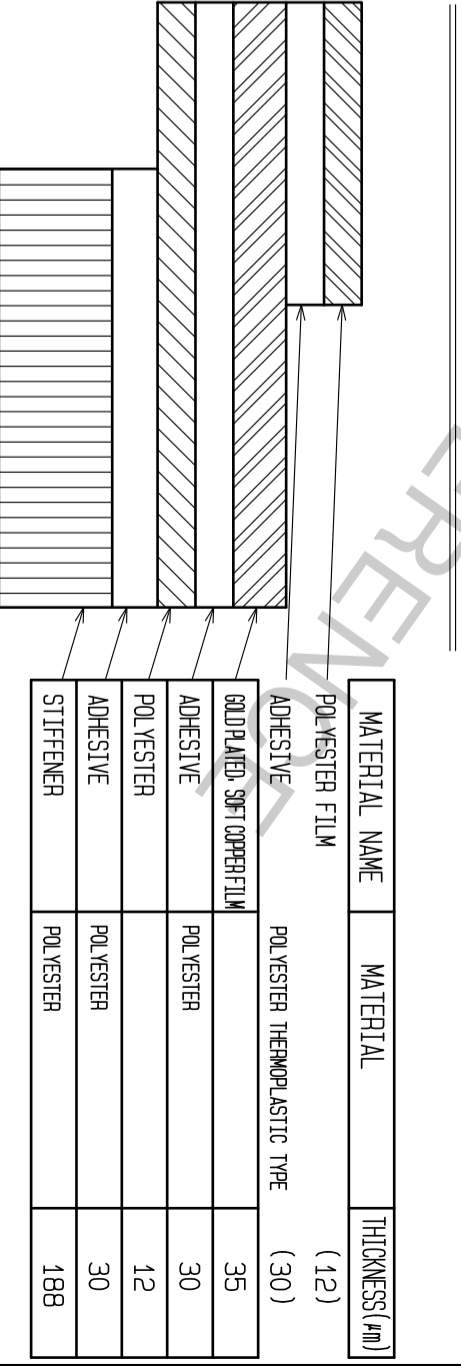

NOTES \triangleright FPC/FFC without tabs is also available.
In case of using FPC/FFC without tabs, dimensions relating tabs are not required.

HRS

DRAWING NO.	EDC-328248-99-00
PART NO.	FH52-**-S-0.5SH(99)
CODE	CL580

EMBOSSED CARRIER TAPE DIMENSION (2:1)

REEL DIMENSIONS (No Scale)

TAPE WIDTH : 24mm MAX

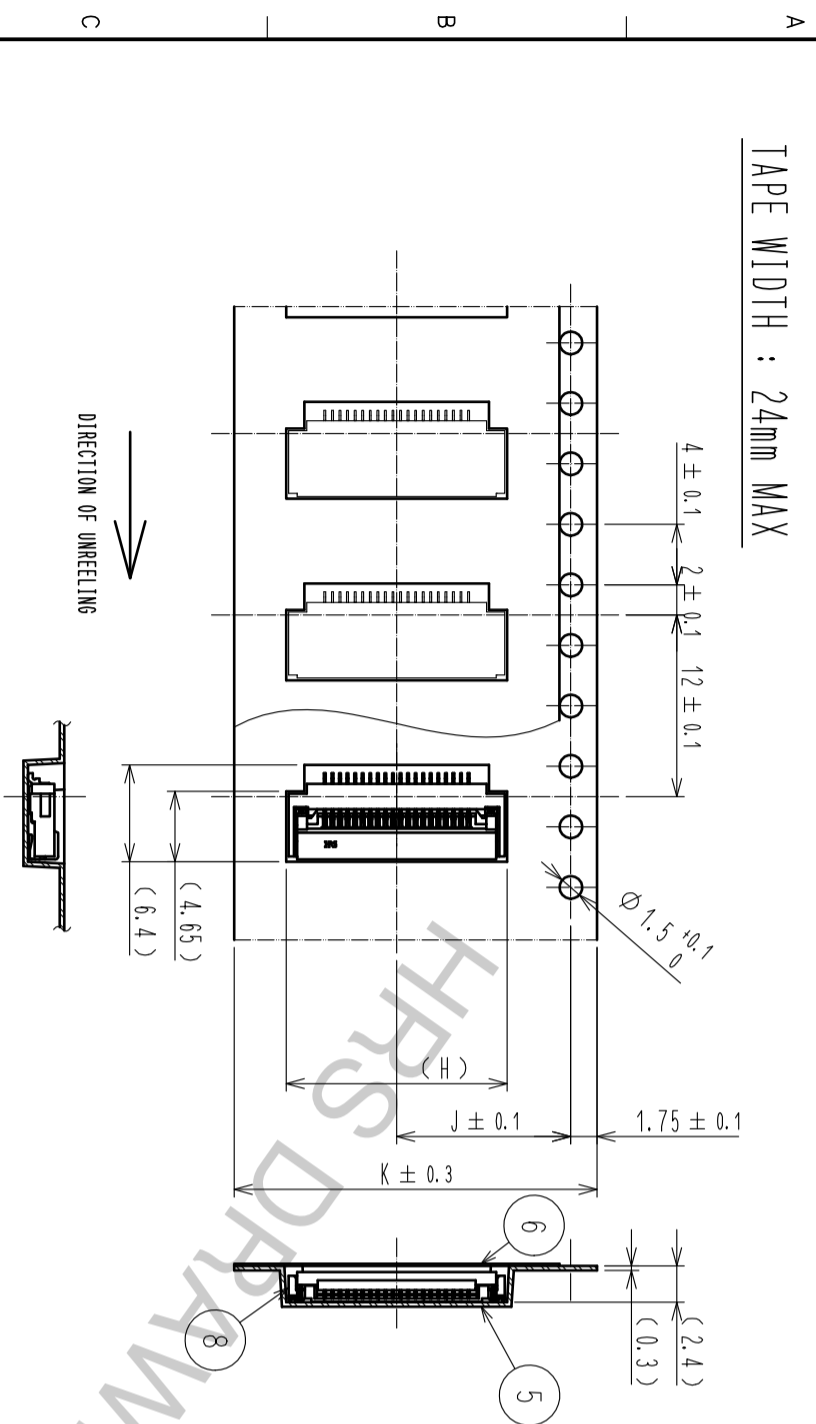

TAPE WIDTH : 32mm MIN

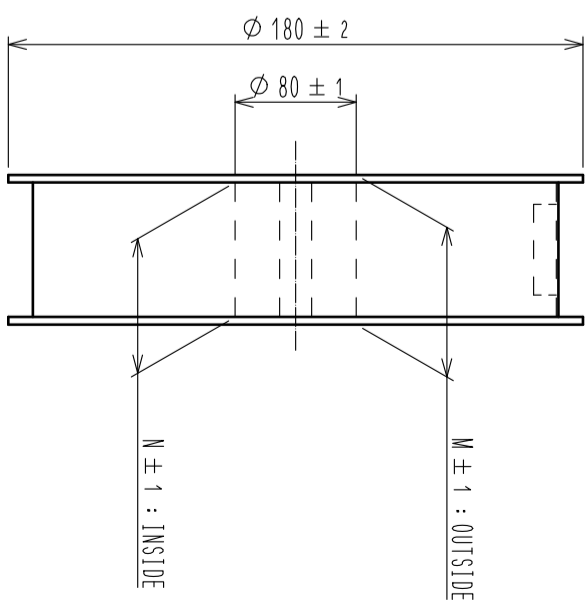
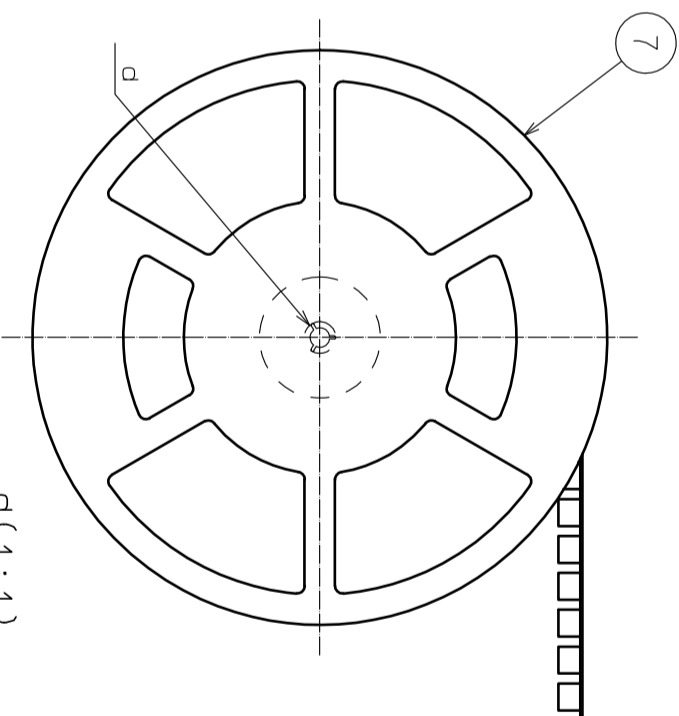
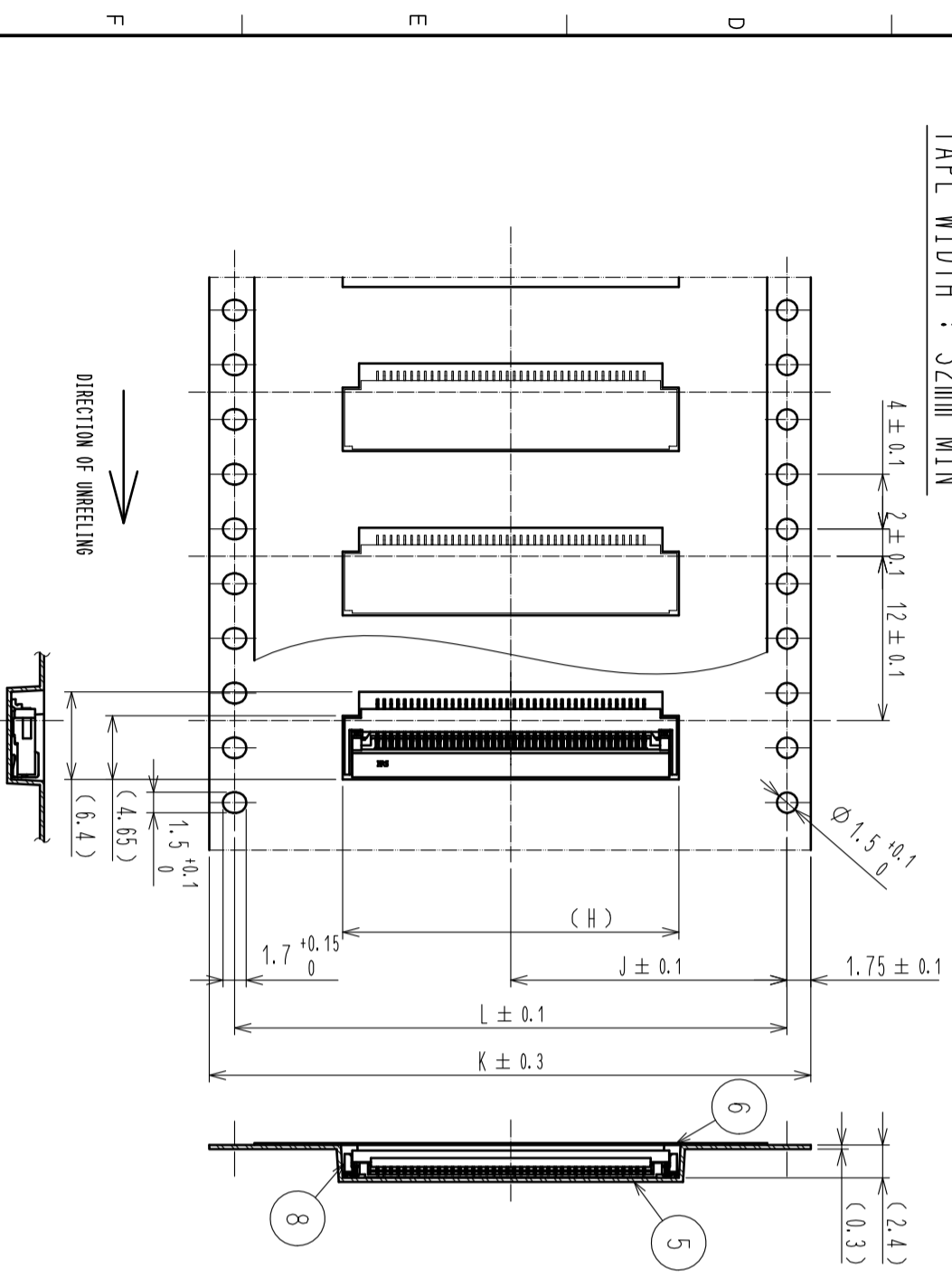

- NOTES
11. 1 reel : 500 connectors.
 12. Refer to JIS C 0806 and IEC 60286-3 (Packaging of components for automatic handling.)

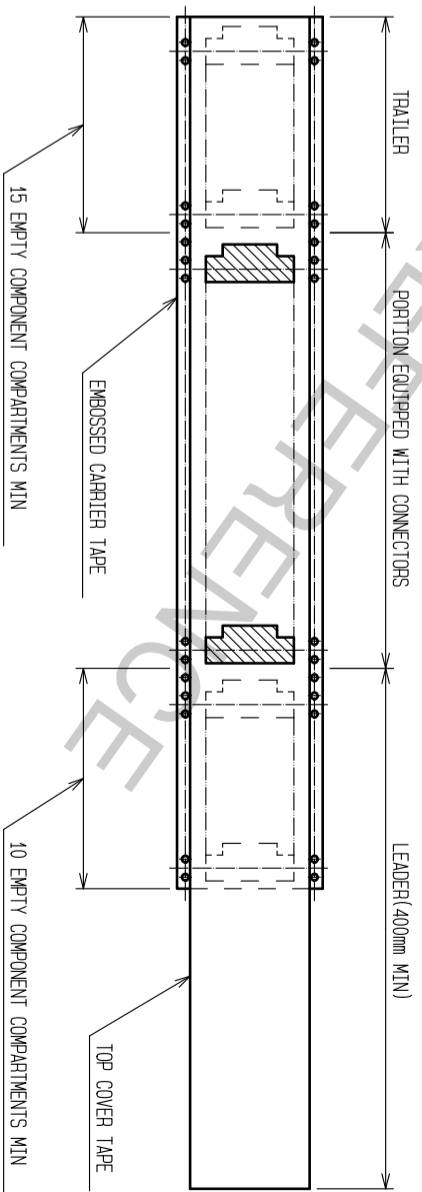

<DRAWING FOR PACKING>

HR5	DRAWING NO.	EDC-328248-99-00
	PART NO.	FH52-**-S-0.5SH(99)
	CODE	CL580

PART NO.	CODE NO.	NUMBER OF CONTACT	DIMENSION OF CONNECTOR/LAND PATTERN/METAL MASK AND FCC/FPC												
			A	B	C	D	E	F	G	H	J	K	L	M	N
FH52-4S-0.5SH(99)		4	6.3	1.5	2.57	4.7	4.1	4.1	2.5	6.6	7.5	16.0	—	21.4	17.4
FH52-5S-0.5SH(99)		5	6.8	2.0	3.07	5.2	4.6	4.6	3.0	7.1	11.5	24.0	—	29.4	25.4
FH52-6S-0.5SH(99)	CL580-3304-0-99	6	7.3	2.5	3.57	5.7	5.1	5.1	3.5	7.6	11.5	24.0	—	29.4	25.4
FH52-8S-0.5SH(99)	CL580-3305-3-99	8	8.3	3.5	4.57	6.7	6.1	6.1	4.5	8.6	11.5	24.0	—	29.4	25.4
FH52-10S-0.5SH(99)	CL580-3306-6-99	10	9.3	4.5	5.57	7.7	7.1	7.1	5.5	9.6	11.5	24.0	—	29.4	25.4
FH52-11S-0.5SH(99)	CL580-3320-7-99	11	9.8	5.0	6.07	8.2	7.6	7.6	6.0	10.1	11.5	24.0	—	29.4	25.4
FH52-12S-0.5SH(99)	CL580-3307-9-99	12	10.3	5.5	6.57	8.7	8.1	8.1	6.5	10.6	11.5	24.0	—	29.4	25.4
FH52-15S-0.5SH(99)	CL580-3302-5-99	15	11.8	7.0	8.07	10.2	9.6	9.6	8.0	12.1	11.5	24.0	—	29.4	25.4
FH52-16S-0.5SH(99)		16	12.3	7.5	8.57	10.7	10.1	10.1	8.5	12.6	11.5	24.0	—	29.4	25.4
FH52-18S-0.5SH(99)	CL580-3321-0-99	18	13.3	8.5	9.57	11.7	11.1	11.1	9.5	13.6	11.5	24.0	—	29.4	25.4
FH52-20S-0.5SH(99)	CL580-3309-4-99	20	14.3	9.5	10.57	12.7	12.1	12.1	10.5	14.6	11.5	24.0	—	29.4	25.4
FH52-22S-0.5SH(99)	CL580-3317-2-99	22	15.3	10.5	11.57	13.7	13.1	13.1	11.5	15.6	14.2	32.0	28.4	37.4	33.4
FH52-24S-0.5SH(99)	CL580-3318-5-99	24	16.3	11.5	12.57	14.7	14.1	14.1	12.5	16.6	14.2	32.0	28.4	37.4	33.4
FH52-25S-0.5SH(99)	CL580-3316-0-99	25	16.8	12.0	13.07	15.2	14.6	14.6	13.0	17.1	14.2	32.0	28.4	37.4	33.4
FH52-26S-0.5SH(99)	CL580-3319-8-99	26	17.3	12.5	13.57	15.7	15.1	15.1	13.5	17.6	14.2	32.0	28.4	37.4	33.4
FH52-28S-0.5SH(99)	CL580-3324-8-99	28	18.3	13.5	14.57	16.7	16.1	16.1	14.5	18.6	14.2	32.0	28.4	37.4	33.4
FH52-30S-0.5SH(99)	CL580-3310-3-99	30	19.3	14.5	15.57	17.7	17.1	17.1	15.5	19.6	14.2	32.0	28.4	37.4	33.4
FH52-32S-0.5SH(99)	CL580-3325-0-99	32	20.3	15.5	16.57	18.7	18.1	18.1	16.5	20.6	20.2	44.0	40.4	49.4	45.4
FH52-40S-0.5SH(99)	CL580-3300-0-99	40	24.3	19.5	20.57	22.7	22.1	22.1	20.5	24.6	20.2	44.0	40.4	49.4	45.4
FH52-42S-0.5SH(99)	CL580-3329-1-99	42	25.3	20.5	21.57	23.7	23.1	23.1	21.5	25.6	20.2	44.0	40.4	49.4	45.4
FH52-45S-0.5SH(99)	CL580-3311-6-99	45	26.8	22.0	23.07	25.2	24.6	24.6	23.0	27.1	20.2	44.0	40.4	49.4	45.4
FH52-50S-0.5SH(99)	CL580-3303-8-99	50	29.3	24.5	25.57	27.7	27.1	27.1	25.5	29.6	20.2	44.0	40.4	49.4	45.4
FH52-60S-0.5SH(99)	CL580-3301-2-99	60	34.3	29.5	30.57	32.7	32.1	32.1	30.5	34.6	26.2	56.0	52.4	61.4	57.4

※CONTACT POSITIONS WITHOUT CODE NUMBERS ARE CURRENTLY UNDER PLANNING.
PLEASE CONTACT HIROSE FOR DETAILED INFORMATION ABOUT PRODUCT VARIATION.

REFERENCE

HRS	
DRAWING NO.	EDC-328248-99-00
PART NO.	FH52-**-S-0.5SH(99)
CODE NO.	CL580
4/6	

This connector requires delicate and careful handling.
Read through the instructions shown below and handle the connector properly.
Each values indicating here are for reference and may differ from standard value.

INSTRUCTIONS FOR MOUNTING ON THE BOARD

- ◆ **Warp of Board**
Minimize warp of the board as much as possible.
Lead co-planarity including reinforced metal fittings is 0.1 mm or less.
Too much warp of the board may result in a soldering failure.
- ◆ **Load to Connector**
Do not apply a force of 1 N or more to the connector before mounting it on the board.
Otherwise, the connector may be broken.
Do not insert the FFC/FPC or operate the connector before mounting it.
- ◆ **Load to Board**
 - Splitting a large board into several pieces
 - Screwing the board
 Avoid the handling described above so that no force is exerted on the board during the assembly process.
Otherwise, the connector may become defective.
- ◆ **Amount of Warp**
The warp of a 100mm wide board should be 1 mm or less.
The warp of board suffers stress on connector and the connector may become defective.

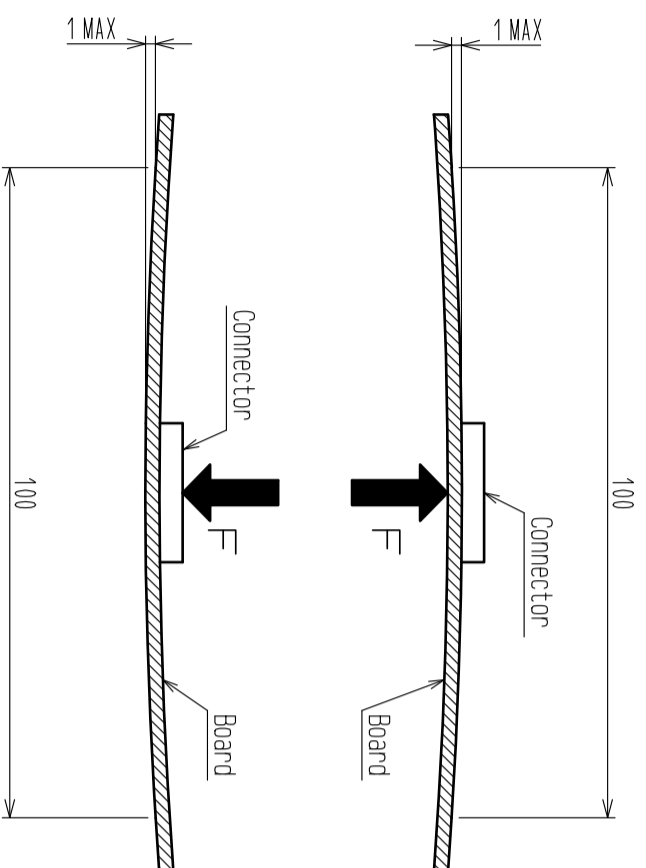

INSTRUCTIONS ON INSERTING FFC/FPC AND CONNECTION

- ◆ **Use of the Actuator**
 1. Be very careful not to apply excessive force when releasing the actuator in the initial position.
If you use your nail or finger as shown below, the terminals may be deformed.
 2. The actuator rotates around the rotational axis as shown below.
 3. The actuator will not open more than 110°. Do not apply any force backward beyond this point. Otherwise, the actuator may come off or break.
 4. Move the actuator at approximately the center.
 5. Do not pinch or pick the actuator to lift it as shown below. Otherwise, it may break.
(Do not carry out any operation other than rotating the actuator as shown in 2 above.)

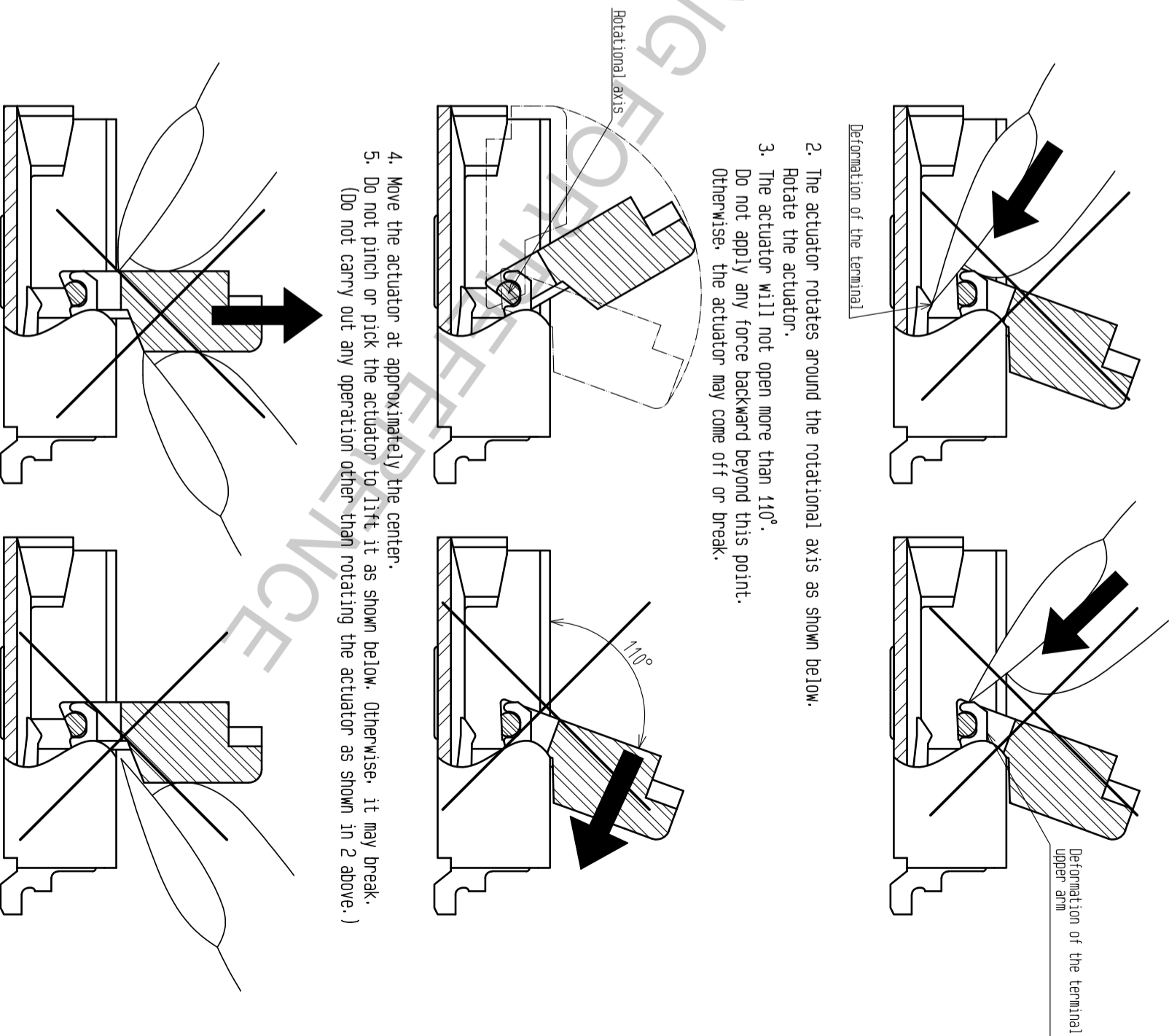

< INSTRUCTION MANUAL(1) >

HR5	DRAWING NO.	EDC-328248-99-00
	PART NO.	FH52-**-S-0.5SH(99)
	CODE	CL580

- ◆ Direction of Contacts
This connector has contacts on the bottom. Thus, insert FFC/FPC with the exposed conductors face down.
- ◆ Inserting the FFC/FPC
 1. Insert the FFC/FPC by about 10 degrees along the surface and at a right angle to the connector. Insert it properly to the very end.

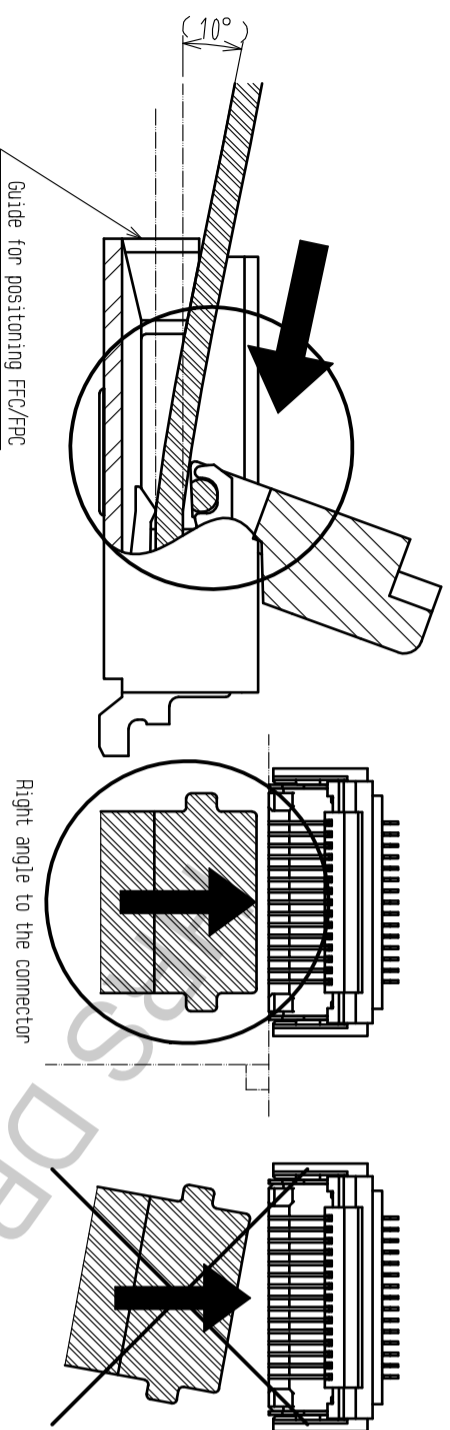

2. Do not insert the FFC/FPC diagonally from above.
If the FFC/FPC is inserted at a slant (incorrectly) as shown below in the FFC/FPC insertion process, the edge of the FFC/FPC may catch in the terminals, resulting in deformation of the terminals. The FFC/FPC may bend and patterns may break or the FFC may not insert completely, resulting in improper conduction.

※ Keep a sufficient FFC/FPC insertion space in the stage of the layout in order to avoid incorrect FFC/FPC insertion.
Besides, it is not difficult to insert FFC/FPC correctly all the way to the end. Design the proper layout of parts.

※ Make adjustments with the FFC/FPC manufacturer for FFC/FPC bending performance and wire breakage.

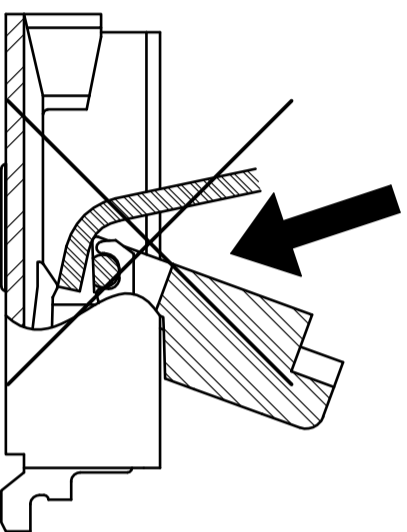

3. Do not rotate the actuator when FFC/FPC TAB is on right and left guides for positioning FFC/FPC. Make sure the position of FFC TAB and guides before rotate the actuator.

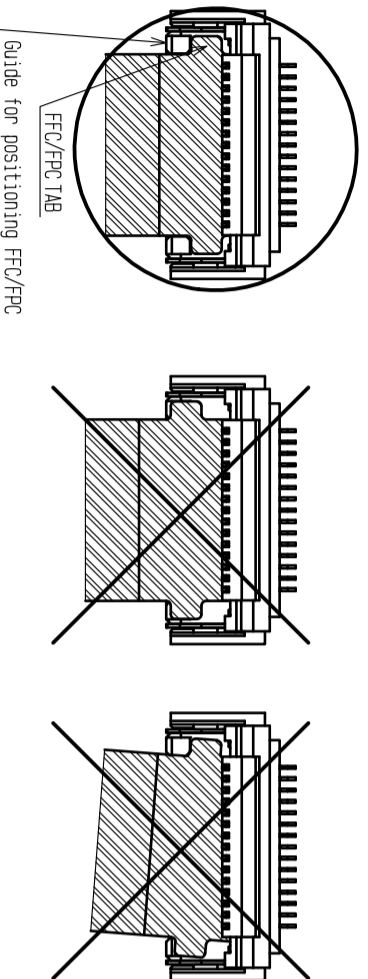

- ◆ Checking the Locking Condition
In the locked condition, make sure that the actuator is horizontal on the board surface. Do not apply excessive force to it near the 0° position of the actuator. Otherwise, the terminals may be deformed.

INSTRUCTIONS ON FFC/FPC LAYOUT AFTER CONNECTION

- ◆ Load to FFC/FPC
Be very careful not to apply any force to the connector directly after inserting FFC/FPC. Otherwise, the connector may become unlocked or the FFC/FPC may break. In particular, design the FFC/FPC layout with care not to bend it sharply upward in a vertical direction near the insertion opening. Fix the FFC/FPC when loads are applied to it continuously.

Load: 0.10 X N N MAX
(n: number of contacts)

INSTRUCTIONS ON REMOVING FFC/FPC

- ◆ Move the actuator at approximately the center.
- ◆ Release the actuator to remove the FFC/FPC.
Remove the FFC/FPC by about 10 degrees along the surface.

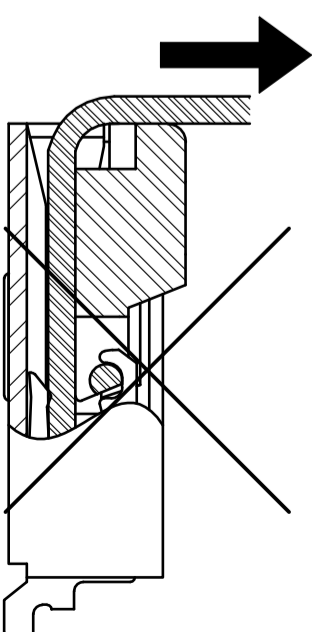

OTHER INSTRUCTIONS

- ◆ Instructions on Manual Soldering
Follow the instructions shown below when soldering the connector manually during repair work, etc.
 1. Do not perform reflow soldering or manual soldering with the FFC inserted into the connector.
 2. Do not heat the connector excessively. Be very careful not to let the soldering iron contact any parts other than connector leads. Otherwise, the connector may be deformed or melt.
 3. Do not use excessive solder (or flux).
 If excessive solder (or flux) is used on the terminals, solder or flux may adhere to the contacts or rotating parts of the actuator, resulting in poor contact or a rotation failure of the actuator. Supplying excessive solder to the reinforcing bracket may hinder actuator rotation, resulting in breakage of the connector.

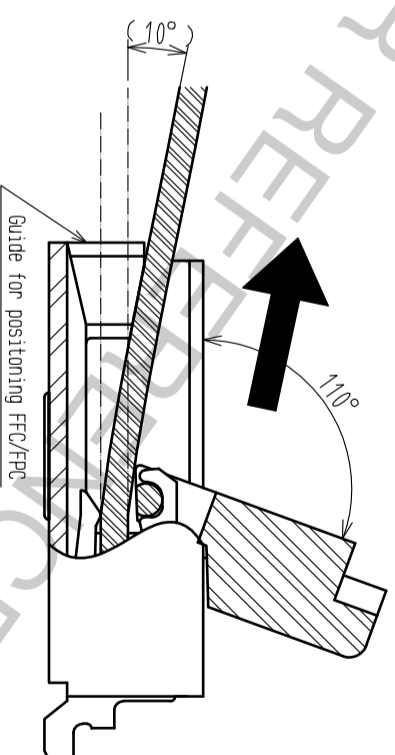

<< INSTRUCTION MANUAL(2) >>

HRS	
DRAWING NO.	EDC-328248-99-00
PART NO.	FH52-**-S-0.5SH(99)
CODE	CL580
NO.	6