



Chipsmall Limited consists of a professional team with an average of over 10 year of expertise in the distribution of electronic components. Based in Hongkong, we have already established firm and mutual-benefit business relationships with customers from,Europe,America and south Asia,supplying obsolete and hard-to-find components to meet their specific needs.

With the principle of “Quality Parts,Customers Priority,Honest Operation,and Considerate Service”,our business mainly focus on the distribution of electronic components. Line cards we deal with include Microchip,ALPS,ROHM,Xilinx,Pulse,ON,Everlight and Freescale. Main products comprise IC,Modules,Potentiometer,IC Socket,Relay,Connector.Our parts cover such applications as commercial,industrial, and automotives areas.

We are looking forward to setting up business relationship with you and hope to provide you with the best service and solution. Let us make a better world for our industry!



Contact us

Tel: +86-755-8981 8866 Fax: +86-755-8427 6832

Email & Skype: info@chipsmall.com Web: www.chipsmall.com

Address: A1208, Overseas Decoration Building, #122 Zhenhua RD., Futian, Shenzhen, China





12V DC Motor 146rpm w/Encoder (SKU: FIT0277)



Contents

- [1 Introduction](#)
- [2 Specification](#)
- [3 Sound testing](#)
- [4 Encoder Diagram](#)
- [5 Encoder Sample Code](#)

Introduction

This is DFRobot customized high quality DC motor. The best part of this motor is that it is a quiet and high torque output motor with optical encoder buildin. The optical encoder gives 663 pluse per rotation which is able to sensor 0.54 degree rotation from the shaft. The resolutiont can meet a general PID speed control requirements.

This motor is widely used in mobile robot area.

Specification

- Model:28PA51G

- Working voltage:12V
- No load RPM (before gearbox):8000 rpm
- Gear ratio: 51:1
- No load RPM (after gearbox): 146rpm@12V
- No load current: @ 12V: 0.23A
- Stall current:3.6A
- Rated torque @ 12V: 10kg.cm (139oz.in)
- Encoder Resolution: 13 PPR (663 PPR for gearbox shaft)
- Two phase hall encoder
- Size:123x36x36mm
- Weight: 270g

Sound testing

Our tests on a common environmental sound emissions shows that the motors have differences. While we thought of averaging the sound emission values, this would not be accurate. Thus we kept the highest value gathered from the tests. The lowest sound emissions reached an average of 57dBA on 40dB indoors environmental sound. These tests where not done in a Acoustic chamber. No load was applied.

For all sound sensitive projects, a sound proof case is recommended for all mechanical parts.

Encoder Diagram

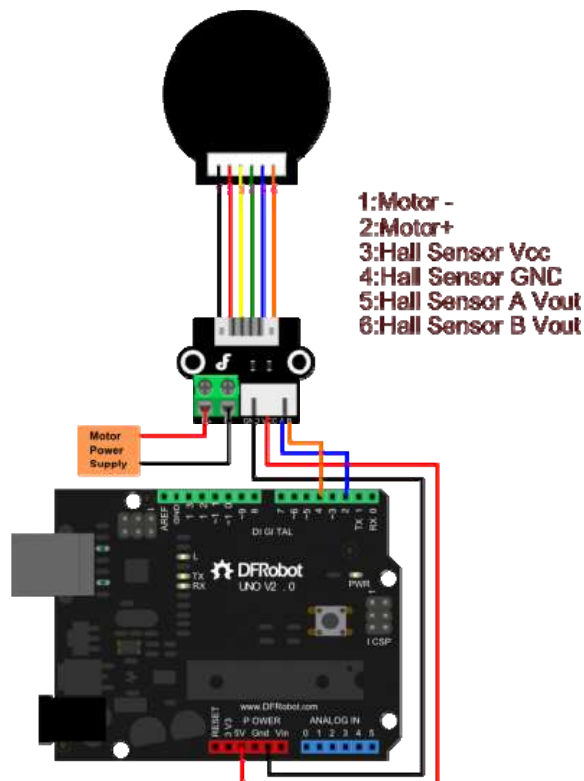

Diagram for using encoder with Encoder Adapter

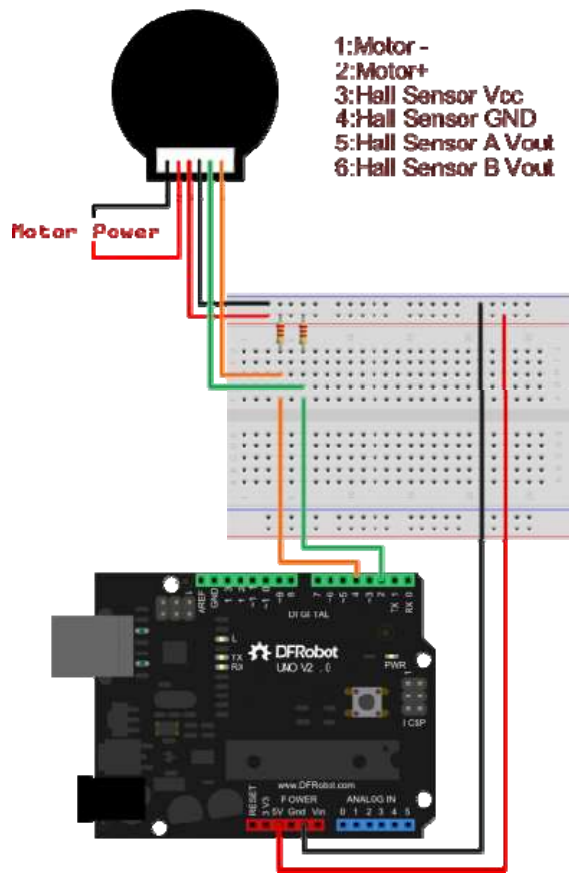

Diagram for using encoder without Encoder Adapter

Encoder Sample Code

```

/*
Pay attention to the interrupt pin, please check which microcontroller you use
.
http://arduino.cc/en/Reference/AttachInterrupt
*/

//The sample code for driving one way motor encoder
const byte encoder0pinA = 2;//A pin -> the interrupt pin 2
const byte encoder0pinB = 4;//B pin -> the digital pin 4
byte encoder0PinALast;
int duration;//the number of the pulses
boolean Direction;//the rotation direction

```

```
void setup()
{
  Serial.begin(57600); //Initialize the serial port
  EncoderInit(); //Initialize the module
}

void loop()
{
  Serial.print("Pulse:");
  Serial.println(duration);
  duration = 0;
  delay(100);
}

void EncoderInit()
{
  Direction = true; //default -> Forward
  pinMode(encoder0pinB, INPUT);
  attachInterrupt(0, wheelSpeed, CHANGE); //int.0
}

void wheelSpeed()
{
  int Lstate = digitalRead(encoder0pinA);
  if((encoder0PinALast == LOW) && Lstate==HIGH)
  {
    int val = digitalRead(encoder0pinB);
    if(val == LOW && Direction)
    {
      Direction = false; //Reverse
    }
    else if(val == HIGH && !Direction)
    {
```

```
        Direction = true; //Forward
    }
}
encoder0PinALast = Lstate;

if(!Direction) duration++;
else duration--;
}
```