



Chipsmall Limited consists of a professional team with an average of over 10 year of expertise in the distribution of electronic components. Based in Hongkong, we have already established firm and mutual-benefit business relationships with customers from,Europe,America and south Asia,supplying obsolete and hard-to-find components to meet their specific needs.

With the principle of "Quality Parts,Customers Priority,Honest Operation,and Considerate Service",our business mainly focus on the distribution of electronic components. Line cards we deal with include Microchip,ALPS,ROHM,Xilinx,Pulse,ON,Everlight and Freescale. Main products comprise IC,Modules,Potentiometer,IC Socket,Relay,Connector.Our parts cover such applications as commercial,industrial, and automotives areas.

We are looking forward to setting up business relationship with you and hope to provide you with the best service and solution. Let us make a better world for our industry!



## Contact us

Tel: +86-755-8981 8866 Fax: +86-755-8427 6832

Email & Skype: info@chipsmall.com Web: www.chipsmall.com

Address: A1208, Overseas Decoration Building, #122 Zhenhua RD., Futian, Shenzhen, China



# 微型直流电机仕様规格书

产品型号：GM15BY-VSM1527-100-10D

## 1. 标准使用条件 (Standard Operating Conditions)

NO.	項目 (Item)	規格 (Specification)	检验方法 (Test Method)
1.1	額定电压 ( Rated Voltage )	DC 12.0V	电压表 ( Multimeter )
1.2	速比 ( Gear Ratio)	1/100	
1.3	马达转向 ( Rotation )	CW&CCW	手感 (Handle)
1.4	姿势 ( Motor Position )	检查时水平 (All position in horizontal)	手感 (Handle)
1.5	检测时时温度范围 Temperature	0 Degree - 30 Degree Celsius	温度计 ( Thermometer )
1.6	检测时时湿度范围 Humidity	30% ~ 95%	湿度计 ( Hygroscope )

## 2. 电机性能 (Performance Of Motors)

NO.	項目 (Item)	規格 (Specification)	检验方法 (Test Method)
2.1	线圈电阻 ( Coil resistance )	30Ω±10%	电阻测试表 (Resistance testing instrument)
2.2	相数 (NO. Of Phases )	2 PHASES	
2.3	步进角 (Step Angle)	18° / Step	角度仪 (Angle gauge)
2.4	最大起动响应频率 ( MAX.Starting Frequency)	900PPS min	步进测试仪 ( Step motor test instrument )
2.5	最大连续响应频率 ( MAX.Slewing Frequency)	1200 PPS min	步进测试仪 ( Step motor test instrument )
2.6	引入力矩 ( Pull IN Torque)	6gf-cm min	步进测试仪 ( Step motor test instrument )
2.7	脱出力矩 ( Lead Out torque )	10gf-cm min	步进测试仪 ( Step motor test instrument )
2.8	绝缘阻抗耐压 ( Insulation impedance voltage )	50MΩ DC100V/300VAC	绝缘耐压测试仪 Dielectric withstanding voltage tester

## 3. 整机性能 ( Performance of Gear motors)

NO.	項目 (Item)	規格 (Specification)	检验方法 (Test Method)
3.1	步进角 (Step Angle)	18/100° / Step	角度仪 (Angle gauge)
3.2	最大起动响应频率 ( MAX.Starting Frequency)	900PPS min	步进测试仪 ( Step motor test instrument )
3.3	最大连续响应频率 ( MAX.Slewing Frequency)	1200 PPS min	步进测试仪 ( Step motor test instrument )
3.4	引入力矩 ( Pull IN Torque)	0.5 Kgf-cm min	步进测试仪 ( Step motor test instrument )
3.5	脱出力矩 ( Lead Out torque )	0.8 kgf-cm Max	步进测试仪 ( Step motor test instrument )

## 4. 基本尺寸 (The Dimension )

NO.	項目 (Item)	規格 ( Specification)	检验方法 (Test Method)
4.1	轴伸尺寸 ( The Outside Shaft Length )	10mm	卡尺 (Vernier Calipers)
4.2	轴向间隙 (Shaft End Play)	0.05-0.30mm	治具 (Frock)
4.3	螺孔 (Screw Size )	M1.6*0.35	治具 (Frock)
4.4	出轴直径 (Dia.of shaft)	Φ3*D2.5mm	卡尺 (Vernier Calipers)
4.5	外形安装尺寸 (Outline Mounting Dimension)	Refer to the Outline Drawing	治具和卡尺 Calipe

## 5. 产品照片 (The product photos)



## 6. 产品外形图 (Product drawings)

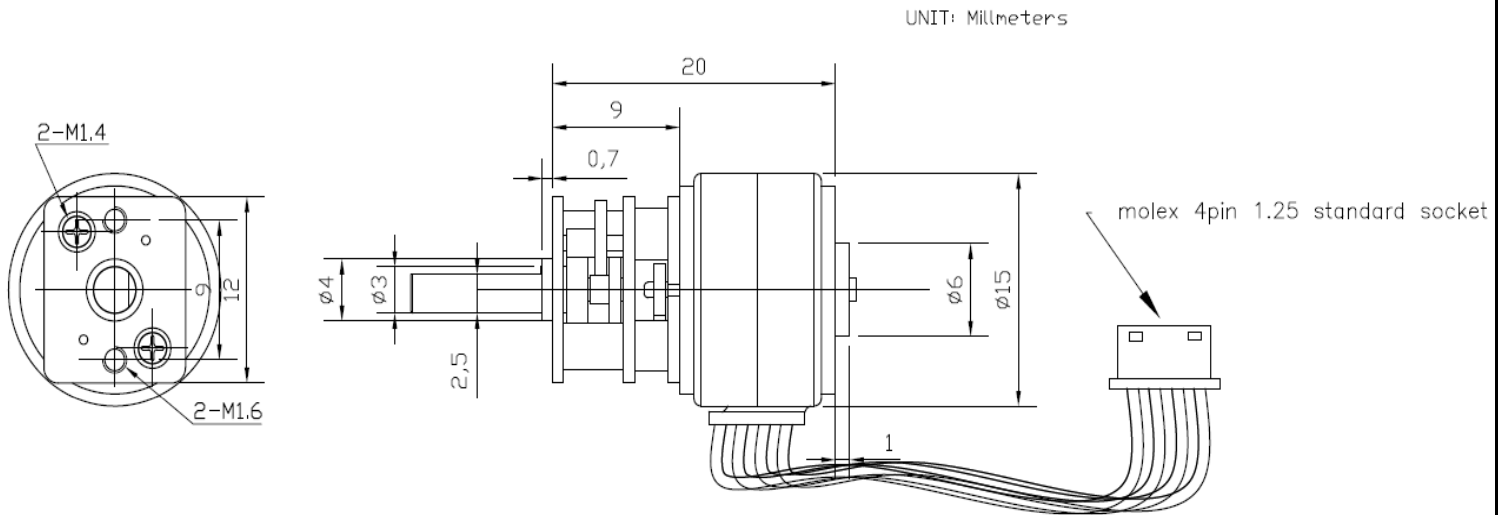

## 7. 接线图 (Wiring diagram)

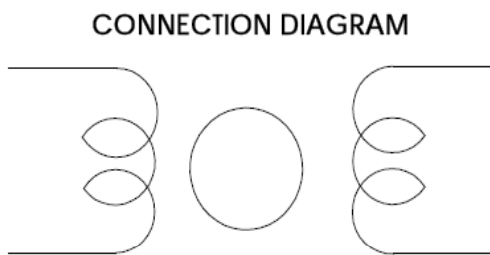

**SEQUENCE OF EXCITATION**

STEP \ PHASE	1	2	3	4
A	+	+	-	-
$\bar{A}$	-	-	+	+
B	-	+	+	-
$\bar{B}$	+	-	-	+

OUTPUT SHAFT ROTATION CCW

