



Chipsmall Limited consists of a professional team with an average of over 10 year of expertise in the distribution of electronic components. Based in Hongkong, we have already established firm and mutual-benefit business relationships with customers from,Europe,America and south Asia,supplying obsolete and hard-to-find components to meet their specific needs.

With the principle of “Quality Parts,Customers Priority,Honest Operation,and Considerate Service”,our business mainly focus on the distribution of electronic components. Line cards we deal with include Microchip,ALPS,ROHM,Xilinx,Pulse,ON,Everlight and Freescale. Main products comprise IC,Modules,Potentiometer,IC Socket,Relay,Connector.Our parts cover such applications as commercial,industrial, and automotives areas.

We are looking forward to setting up business relationship with you and hope to provide you with the best service and solution. Let us make a better world for our industry!



## Contact us

Tel: +86-755-8981 8866 Fax: +86-755-8427 6832

Email & Skype: info@chipsmall.com Web: www.chipsmall.com

Address: A1208, Overseas Decoration Building, #122 Zhenhua RD., Futian, Shenzhen, China



THIS COPY IS PROVIDED ON A RESTRICTED BASIS AND IS NOT TO BE USED IN ANY WAY DETRIMENTAL TO THE INTERESTS OF PANDUIT CORP.

PANDUIT PART NUMBER	WEIGHT
FKS	.14 LB./EACH [ 65.5 GRAMS/EACH ]

NOTES:

1. SEE CURRENT CATALOG FOR ADDITIONAL PART NUMBER SUFFIXES TO INDICATE PACKAGE QUANTITIES.
2. THE TOOL IS CONSTRUCTED OF CARBON STEEL FRAMES WITH A BLACK FINISH AND RUBBER HAND GRIPS.
3. THE CUTTING EDGE IS SERRATED AND HARDENED.
4. THE TOOL HAS A SPRING THAT ALLOWS THE TOOL TO SPRING OPEN AFTER EACH CUT CYCLE.
5. ALL DIMENSIONS IN BRACKETS ARE METRIC [ mm ]

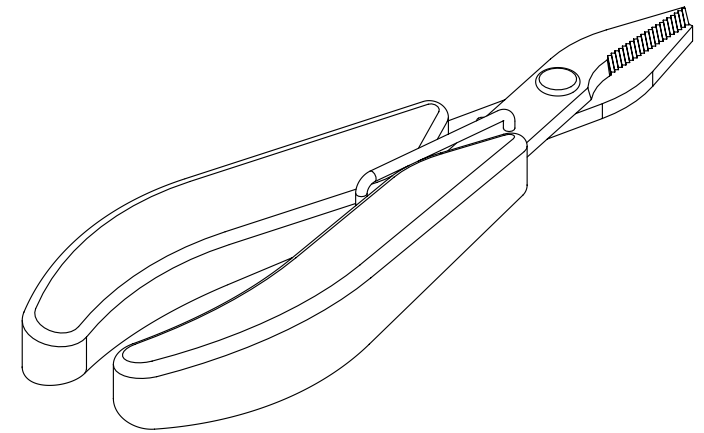
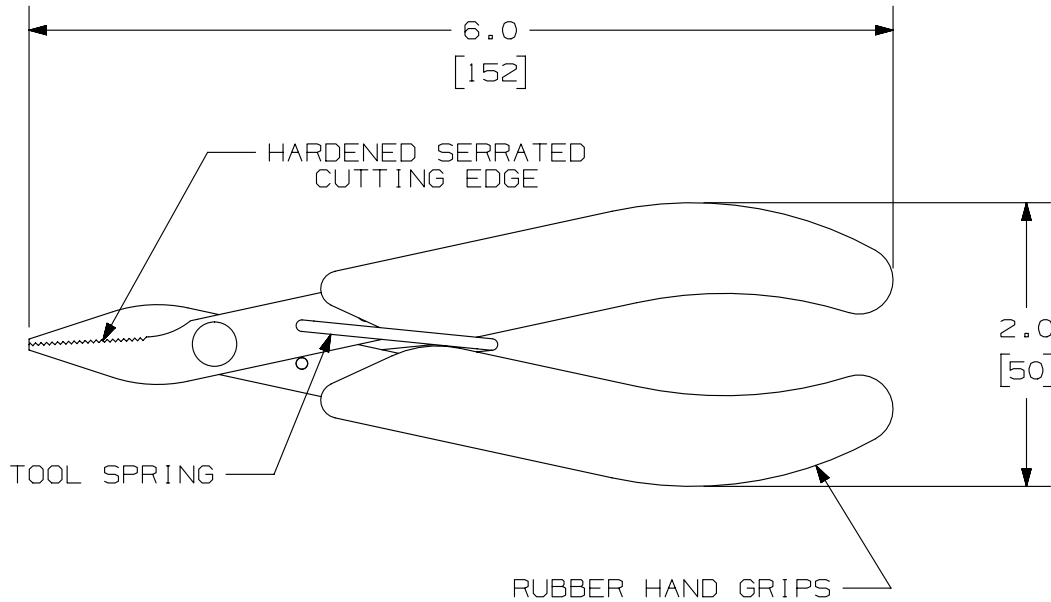

PART NUMBER		FKS	
TITLE			
KEVLAR FIBER CUTTERS		CUSTOMER DRAWING	
ITEM REVISION NAME		M01190BZ/02	
DATASET FILE NAME		M01190BZ_DC/00B	
UNLESS OTHERWISE SPECIFIED, DIMENSIONAL TOLERANCES ARE: IN [ mm ]		MATERIAL:	
.x ± .xxx ± .010 [ .3 ]		DRAWING NUMBER:	
.xx ± .03 [ .8 ] ANGLES ±		01190-24	
THIRD ANGLE PROJECTION		01190-24	
DRAWN BY	DATE	CHK	SCALE
EFK	07-24-03	RTF I	NONE
SHT 1 OF 1		A	

2	2/6/15	JSP	WJM	RWB	A. REVISED DRAWING TITLE BLOCK.	01190-24
REV	DATE	BY	CHK	APR	DESCRIPTION	ECN

D10100DA/14