



Chipsmall Limited consists of a professional team with an average of over 10 year of expertise in the distribution of electronic components. Based in Hongkong, we have already established firm and mutual-benefit business relationships with customers from,Europe,America and south Asia,supplying obsolete and hard-to-find components to meet their specific needs.

With the principle of “Quality Parts,Customers Priority,Honest Operation,and Considerate Service”,our business mainly focus on the distribution of electronic components. Line cards we deal with include Microchip,ALPS,ROHM,Xilinx,Pulse,ON,Everlight and Freescale. Main products comprise IC,Modules,Potentiometer,IC Socket,Relay,Connector.Our parts cover such applications as commercial,industrial, and automotives areas.

We are looking forward to setting up business relationship with you and hope to provide you with the best service and solution. Let us make a better world for our industry!



## Contact us

Tel: +86-755-8981 8866 Fax: +86-755-8427 6832

Email & Skype: info@chipsmall.com Web: www.chipsmall.com

Address: A1208, Overseas Decoration Building, #122 Zhenhua RD., Futian, Shenzhen, China





# FL\_101 USER MANUAL

---

## FlashLink User Manual

---

### CONTENTS

- (Introduction on next page)



# FlashLink

## User Manual

### Features

- ❑ Allows PC parallel port to communicate with PSD813F via PSDsoft
- ❑ Provides interface medium for JTAG communications
- ❑ Supports basic IEEE 1149.1 JTAG signals (TCK, TMS, TDI, TDO)
- ❑ Supports additional signals to enhance download speed (TERR, TSTAT)
- ❑ Can be used for programming and/or testing
- ❑ Wide power supply range of 2.7 to 5.5V
- ❑ Pinout independent with target side flying leads
- ❑ Included loopback connector to validate FlashLink and PC connection
- ❑ Convenient desktop packaging allows varying applications (desk, lab or production)
- ❑ Synchronous JTAG interface allows speeds as fast as pc can drive

### Overview

FlashLink is a hardware interface from a standard PC parallel port to one or more PSD813F devices located within a target pc board as shown below.

This interface cable allows the PSD813F to be exercised for purposes of testing and/or programming. PSDsoft is the software source for driving FlashLink.

**Figure 1. FlashLink Adapter Application**

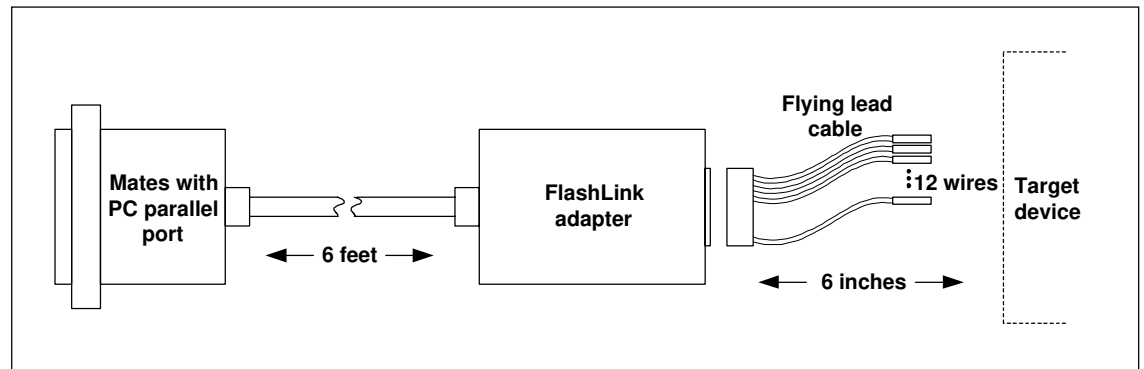

### Operating Considerations

Operating power for FlashLink is derived from the target system in the range of 2.7 to 5.5V. Compatibility over this voltage range is ensured by the design of FlashLink. No settings are involved.

On a cautionary note, it is recommended that the target system be powered with a well regulated and stable source of power which is energized at the final value of  $V_{CC}$ . It is not recommended that the input voltage be varied using the vernier on a regulated power supply, as this may cause the internal FlashLink IC's (74VHC240) to misoperate toward the lower end of the supply range.

## Operating Considerations

(cont.)

**Table 1. Pin Descriptions for FlashLink Adapter Assembly**

| Pin # | Signal Name              | Description<br>JTAG = IEEE 1149.1<br>EJTAG = WSI Enhanced JTAG | Type | FlashLink IS Signal: |
|-------|--------------------------|--|------|----------------------|
| 1     | $\overline{\text{JEN}}$  | JTAG enable on PSD813F (optional)                              | OC   | Source               |
| 2     | $\overline{\text{TRST}}$ | JTAG reset on target (optional per 1149.1)                     | OC   | Source               |
| 3     | <b>GND</b>               | Signal ground  |      |                      |
| 4     | CNTL                     | Generic signal, user defined (optional)                        | OC   | Source               |
| 5     | <b>TDI</b>               | JTAG test data input   |      | Source               |
| 6     | TSTAT                    | EJTAG programming status (optional)                            |      | Destination          |
| 7     | $V_{CC}$                 | VDC source from target   |      |                      |
| 8     | $\overline{\text{RST}}$  | Target system reset (optional)                                 | OC   | Source               |
| 9     | <b>TMS</b>               | JTAG mode select   |      | Source               |
| 10    | GND                      | Signal ground  |      |                      |
| 11    | <b>TCK</b>               | JTAG clock   |      | Source               |
| 12    | GND                      | Signal ground  |      |                      |
| 13    | <b>TDO</b>               | JTAG serial data output  |      | Destination          |
| 14    | $\overline{\text{TERR}}$ | EJTAG programming error (optional)                             |      | Destination          |

### Notes

1. **Bold** signals are required connections.
2. All signal grounds are connected together inside FlashLink.
3. OC = open collector.



## Operating Considerations

(cont.)

**Note:** The target device must supply  $V_{CC}$  to the FlashLink Adapter (2.7 to 5.5 VDC, 15mA max @ 5.5V).

Not all 14 signals may be needed for a given application. Here's how they break down:

- ❑ (6) Core signals that must be connected: TDI, TDO, TMS, TCK,  $V_{CC}$ , GND
- ❑ (2) Optional signals for enhanced ISP: TSTAT,  $\overline{TERR}$
- ❑ (1) Optional signal to control multiplexing of the JTAG signals:  $\overline{JEN}$
- ❑ (1) Optional IEEE-1149.1 signal for JTAG chain reset:  $\overline{TRST}$
- ❑ (1) Optional signal to allow FlashLink to reset target system after ISP:  $\overline{RST}$
- ❑ (1)\* Optional generic control signal to target system from FlashLink: CNTL
- ❑ (2) Two additional ground lines to help reduce EMI if a ribbon cable is used. These ground lines "sandwich" the TCK signal in the ribbon cable.

\* = Not supported initially by PSDsoft

### Target Side Pinouts

There is no industry "standard" JTAG connector. Each manufacturer differs. ST has a specific connector and pinout for the FlashLink programmer adapter. The connector scheme on the FlashLink adapter can accept a standard 14 pin ribbon connector (2 rows of 7 pins on 0.1" centers, standard keying) or any other user specific connector that can slide onto 0.025" square posts. The pinout for the FlashLink adapter connector is shown in Figure 2.

If a standard ribbon cable is used for quick connection of the FlashLink adapter to the target circuit card assembly, then the target system should use the pinout as shown in Figure 2.

**Figure 2. JTAG Connector Recommended Pinouts**

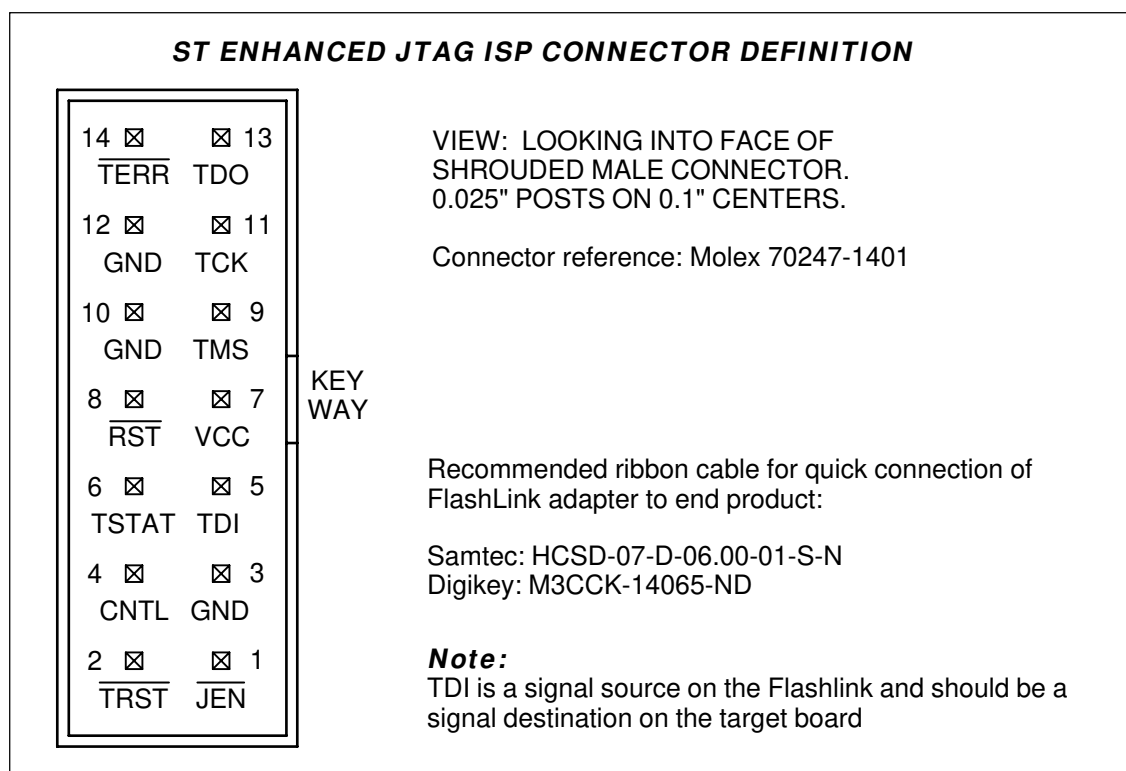
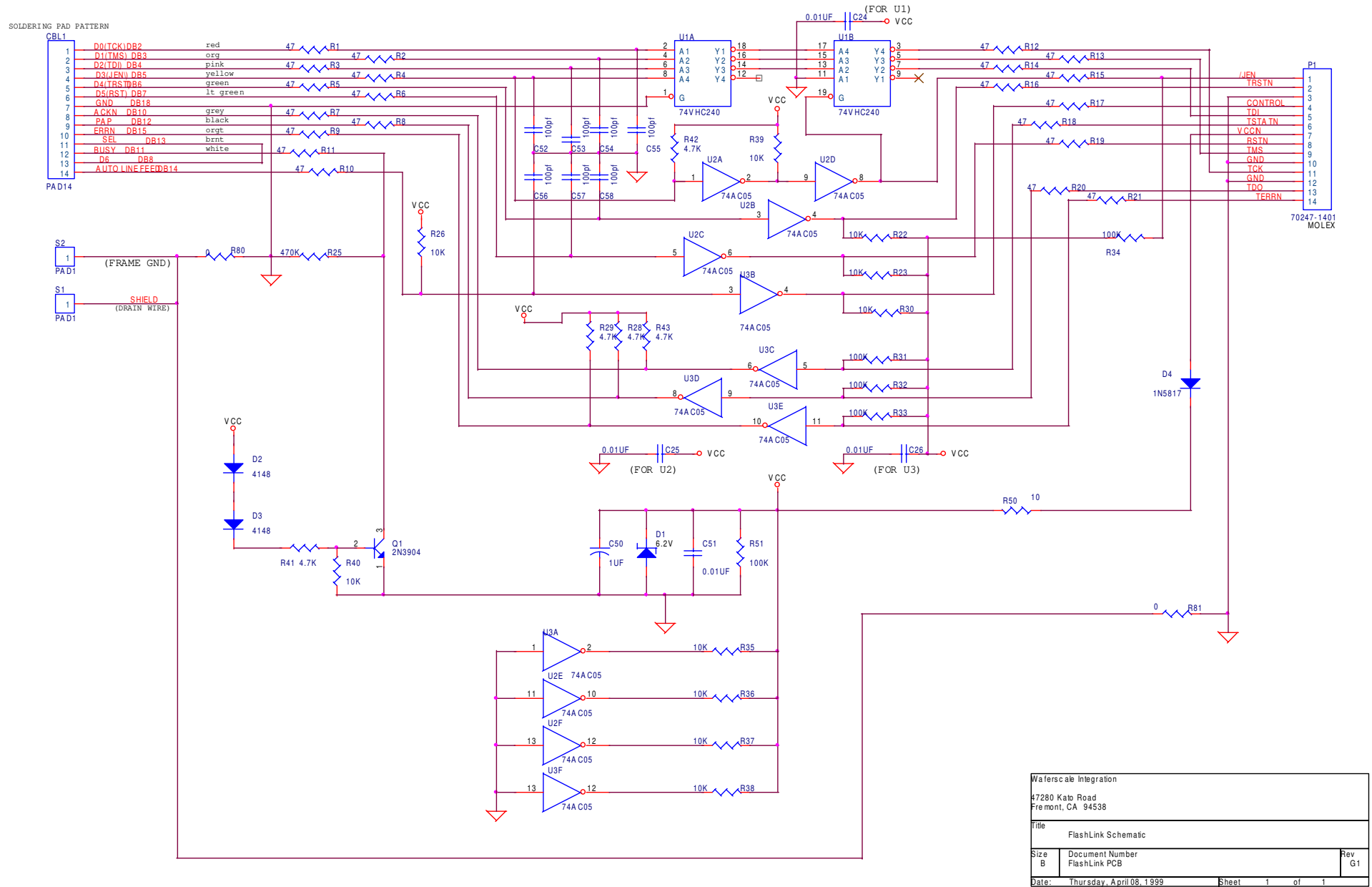

Figure 3. FlashLink Schematic



|                                      |                                |         |
|--------------------------------------|--------------------------------|---------|
| Waterscale Integration               |                                |         |
| 47280 Katb Road<br>Fremont, CA 94538 |                                |         |
| Title: FlashLink Schematic           |                                |         |
| Size: B                              | Document Number: FlashLink PCB | Rev: G1 |
| Date: Thursday, April 08, 1999       | Sheet: 1 of 1                  |         |



**Operating Considerations**

(cont.)

A schematic of FlashLink is shown on the previous page.

For further information, see the *PSDsoft Users Manual*.

**Note:** This equipment has been tested and found to comply with the limits for a Class A digital device, pursuant to Part 15 of the FCC Rules. These limits are designed to provide reasonable protection against harmful interference when the equipment is operated in a commercial environment. This equipment generates, uses, and can radiate radio frequency energy and, if not installed and used in accordance with the instruction manual, may cause harmful interference to radio communications. Operation of this equipment in a residential area is likely to cause harmful interference in which case the user will be required to correct the interference at his own expense.

**Figure 4. Chaining Example**

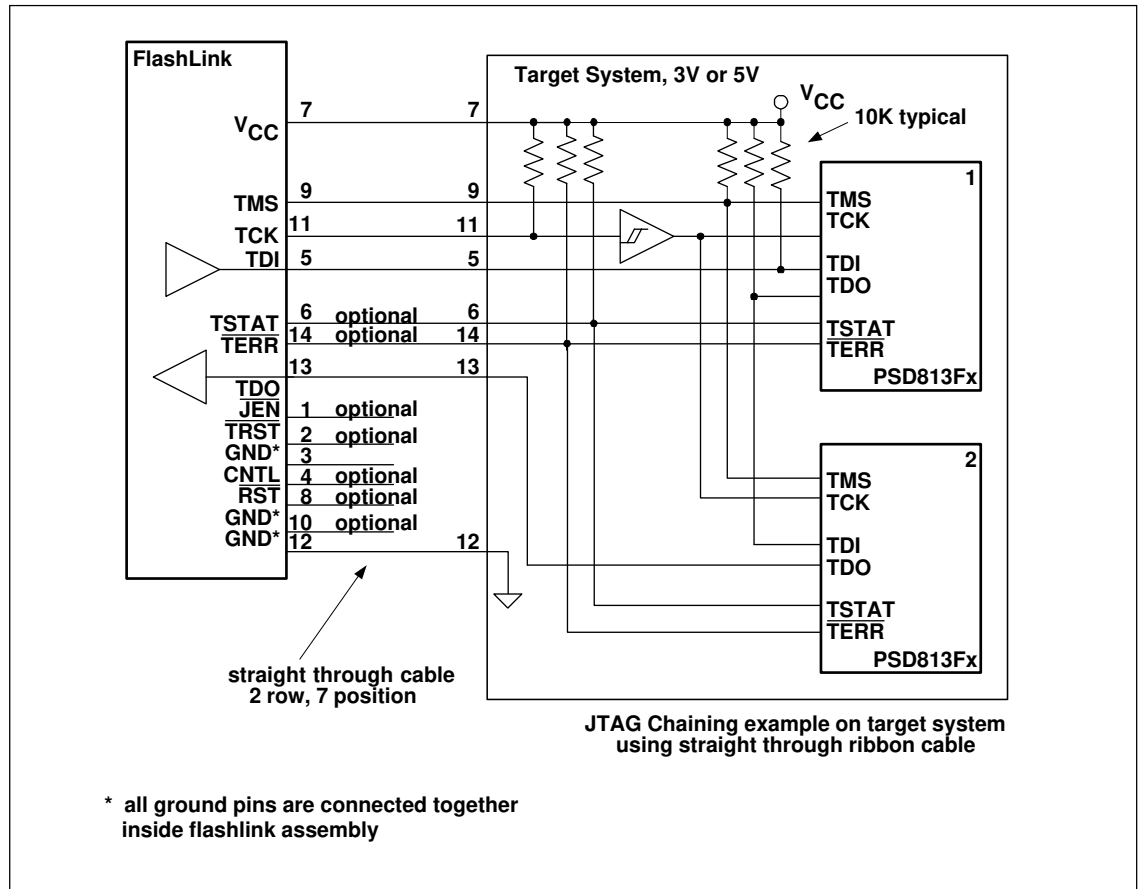

## Operating Considerations

(cont.)

Figure 5. Loopback Adaptor

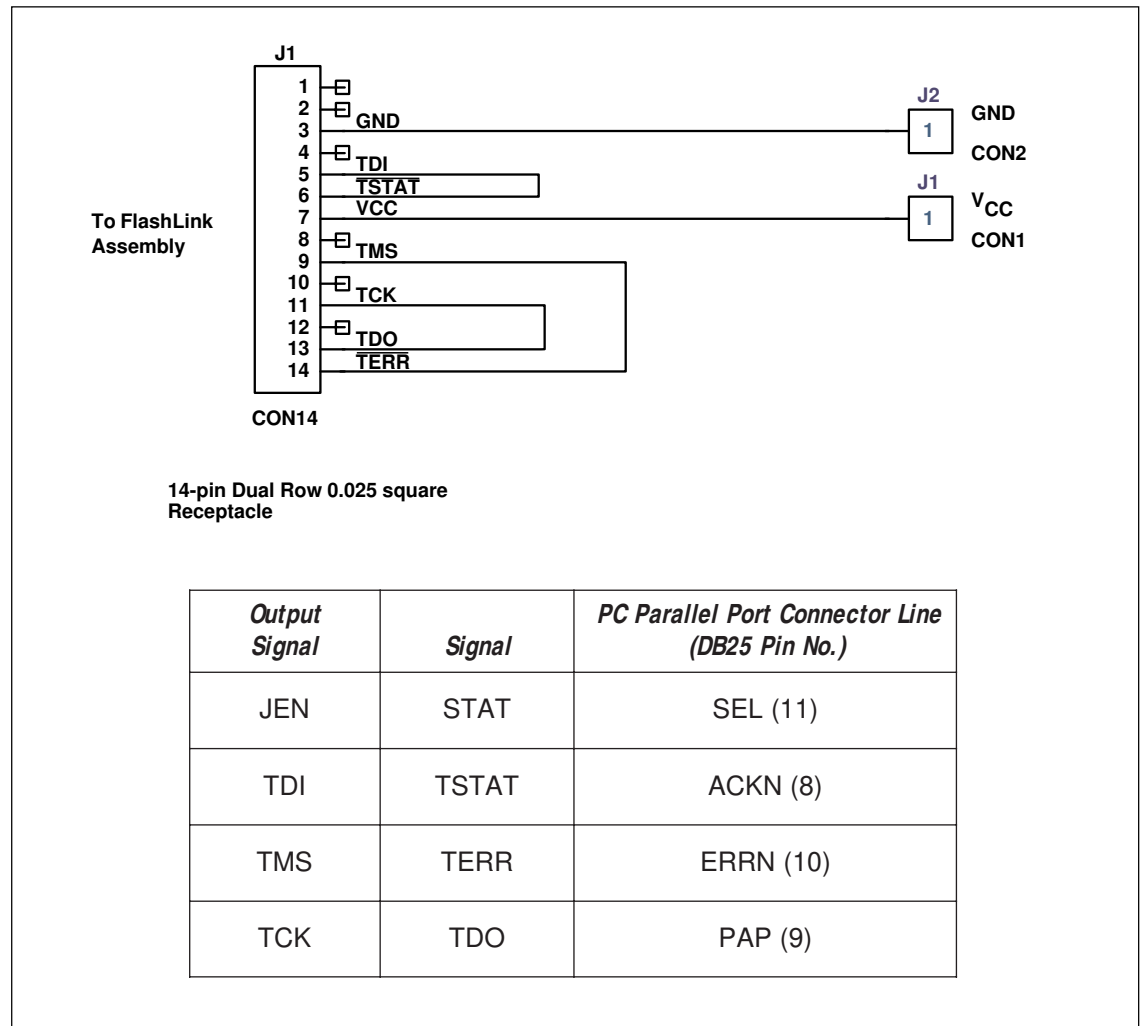



## FL\_101 - USER MANUAL

---

**Table 1. Document Revision History**

| Date        | Rev. | Description of Revision  |
|-------------|------|--|
|             | 1.0  | Document written in the WSI format   |
| 30-Jan-2002 | 1.1  | FL_101: FlashLink User Manual<br>Front page, and back two pages, in ST format, added to the PDF file<br>Any references to Waferscale, WSI, EasyFLASH and PSDsoft 2000 updated to ST, ST, Flash+PSD and PSDsoft Express |

For current information on PSD products, please consult our pages on the world wide web:

*[www.st.com/psm](http://www.st.com/psm)*

If you have any questions or suggestions concerning the matters raised in this document, please send them to the following electronic mail addresses:

*[apps.psd@st.com](mailto:apps.psd@st.com)*            (for application support)  
*[ask.memory@st.com](mailto:ask.memory@st.com)*        (for general enquiries)

Please remember to include your name, company, location, telephone number and fax number.

Information furnished is believed to be accurate and reliable. However, STMicroelectronics assumes no responsibility for the consequences of use of such information nor for any infringement of patents or other rights of third parties which may result from its use. No license is granted by implication or otherwise under any patent or patent rights of STMicroelectronics. Specifications mentioned in this publication are subject to change without notice. This publication supersedes and replaces all information previously supplied. STMicroelectronics products are not authorized for use as critical components in life support devices or systems without express written approval of STMicroelectronics.

The ST logo is registered trademark of STMicroelectronics  
All other names are the property of their respective owners

© 2002 STMicroelectronics - All Rights Reserved

STMicroelectronics group of companies Australia - Brazil - Canada - China - Finland - France - Germany - Hong Kong -  
India - Israel - Italy - Japan - Malaysia - Malta - Morocco - Singapore - Spain - Sweden - Switzerland - United Kingdom - United States.

**[www.st.com](http://www.st.com)**

