



Chipsmall Limited consists of a professional team with an average of over 10 year of expertise in the distribution of electronic components. Based in Hongkong, we have already established firm and mutual-benefit business relationships with customers from,Europe,America and south Asia,supplying obsolete and hard-to-find components to meet their specific needs.

With the principle of "Quality Parts,Customers Priority,Honest Operation,and Considerate Service",our business mainly focus on the distribution of electronic components. Line cards we deal with include Microchip,ALPS,ROHM,Xilinx,Pulse,ON,Everlight and Freescale. Main products comprise IC,Modules,Potentiometer,IC Socket,Relay,Connector.Our parts cover such applications as commercial,industrial, and automotives areas.

We are looking forward to setting up business relationship with you and hope to provide you with the best service and solution. Let us make a better world for our industry!



Contact us

Tel: +86-755-8981 8866 Fax: +86-755-8427 6832

Email & Skype: info@chipsmall.com Web: www.chipsmall.com

Address: A1208, Overseas Decoration Building, #122 Zhenhua RD., Futian, Shenzhen, China





Is Now Part of



ON Semiconductor®

To learn more about ON Semiconductor, please visit our website at
www.onsemi.com

ON Semiconductor and the ON Semiconductor logo are trademarks of Semiconductor Components Industries, LLC dba ON Semiconductor or its subsidiaries in the United States and/or other countries. ON Semiconductor owns the rights to a number of patents, trademarks, copyrights, trade secrets, and other intellectual property. A listing of ON Semiconductor's product/patent coverage may be accessed at www.onsemi.com/site/pdf/Patent-Marking.pdf. ON Semiconductor reserves the right to make changes without further notice to any products herein. ON Semiconductor makes no warranty, representation or guarantee regarding the suitability of its products for any particular purpose, nor does ON Semiconductor assume any liability arising out of the application or use of any product or circuit, and specifically disclaims any and all liability, including without limitation special, consequential or incidental damages. Buyer is responsible for its products and applications using ON Semiconductor products, including compliance with all laws, regulations and safety requirements or standards, regardless of any support or applications information provided by ON Semiconductor. "Typical" parameters which may be provided in ON Semiconductor data sheets and/or specifications can and do vary in different applications and actual performance may vary over time. All operating parameters, including "Typicals" must be validated for each customer application by customer's technical experts. ON Semiconductor does not convey any license under its patent rights nor the rights of others. ON Semiconductor products are not designed, intended, or authorized for use as a critical component in life support systems or any FDA Class 3 medical devices or medical devices with a same or similar classification in a foreign jurisdiction or any devices intended for implantation in the human body. Should Buyer purchase or use ON Semiconductor products for any such unintended or unauthorized application, Buyer shall indemnify and hold ON Semiconductor and its officers, employees, subsidiaries, affiliates, and distributors harmless against all claims, costs, damages, and expenses, and reasonable attorney fees arising out of, directly or indirectly, any claim of personal injury or death associated with such unintended or unauthorized use, even if such claim alleges that ON Semiconductor was negligent regarding the design or manufacture of the part. ON Semiconductor is an Equal Opportunity/Affirmative Action Employer. This literature is subject to all applicable copyright laws and is not for resale in any manner.



FLS3217 / FLS3247

Single-Stage PFC Primary-Side-Regulation Offline LED Driver with Integrated Power MOSFET

Features

- Cost-Effective Solution without Input Bulk Capacitor and Feedback Circuitry
- Power-Factor Correction (PFC)
- Integrated Power MOSFET
- Accurate Constant-Current (CC) Control Independent Online Voltage, Output Voltage, and Magnetizing Inductance Variation
- Linear Frequency Control for Increased Efficiency
- Open / Short-LED Protection
- Cycle-by-Cycle Current Limiting
- Over-Temperature Protection with Auto Restart
- Low Startup Current: 20 μ A
- Low Operating Current: 5mA
- V_{DD} Over-Voltage Protection (OVP)
- V_{DD} Under-Voltage Lockout (UVLO)
- Application Voltage Range: 80 V_{AC} ~ 308 V_{AC}

Applications

- LED Lighting System

Description

This highly integrated PWM controller with power MOSFET, FLS3217 / FLS3247, provides several features to enhance the performance of low-power flyback converters. The proprietary topology enables simplified circuit design for LED lighting applications.

By using the single-stage topology with primary-side regulation, an LED lighting board can be implemented with the few external components and minimized cost; requiring no input bulk capacitor or feedback circuitry. To implement good power factor and low THD, constant on-time control is utilized with an external capacitor connected to COMI.

Precise constant-current control regulates accurate output current versus changes in input voltage and output voltage. The operating frequency is proportionally changed by the output voltage to guarantee DCM operation with higher efficiency and simple design.

FLS3217 and FLS3247 provide protection features such as open-LED, short-LED, and over-temperature protection. The current-limit level is automatically reduced to minimize the output current and protect external components in short-LED condition.

Ordering Information

Part Number	Operating Temperature Range	Package	Packing Method
FLS3217M	-40°C to +125°C	7-Lead, Small Outline Package (SOIC)	Tape & Reel
FLS3217N		7-Lead, Small Outline Package (DIP)	Tube
FLS3247N			

Application Diagram

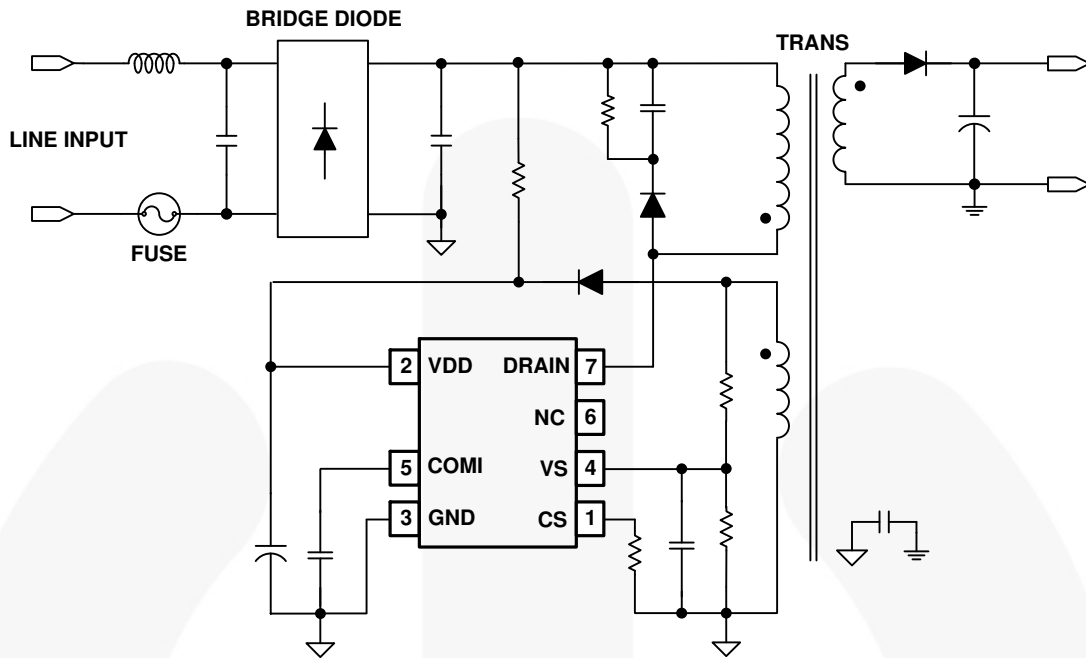

Figure 1. Typical Application

Internal Block Diagram

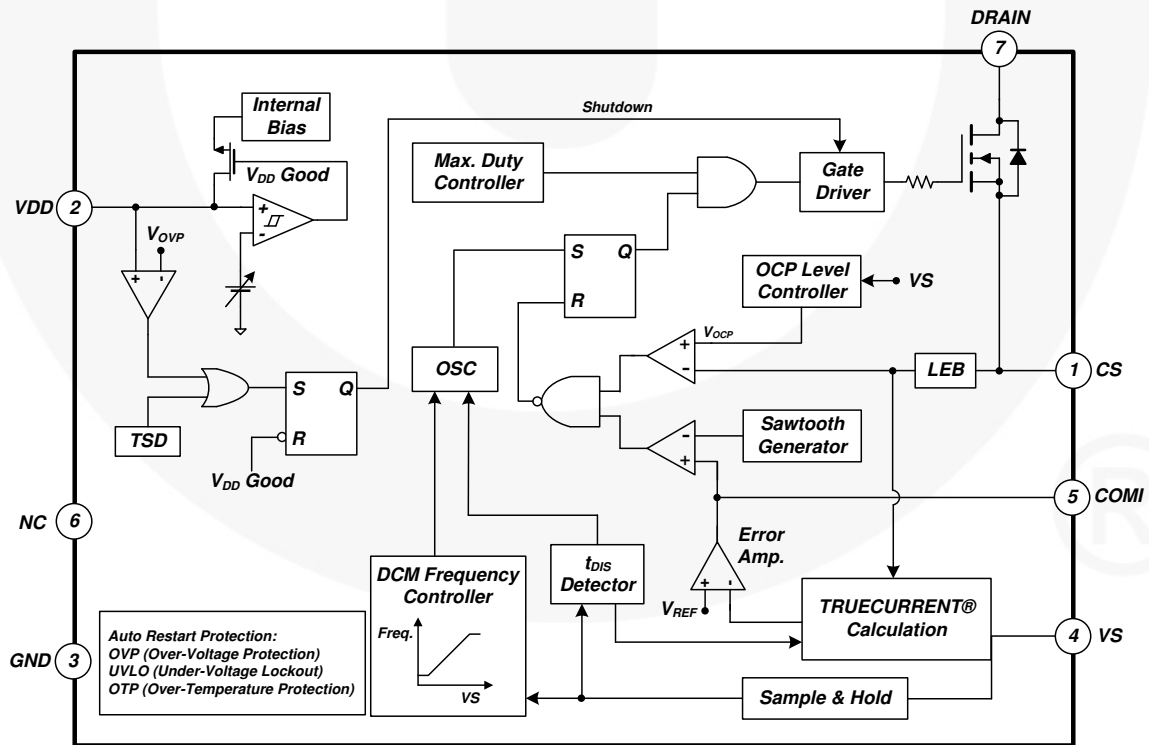

Figure 2. Functional Block Diagram

Marking Information

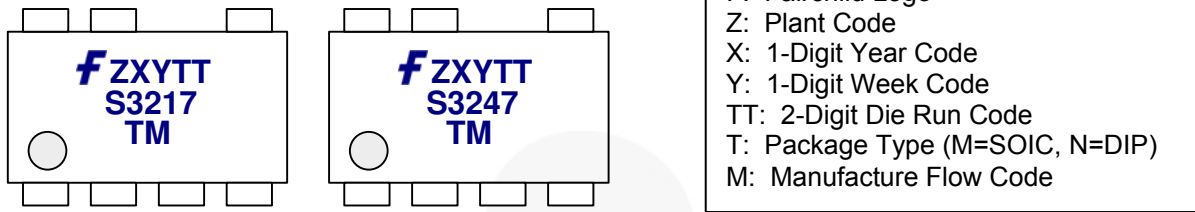

Figure 3. Top Mark

Pin Configuration

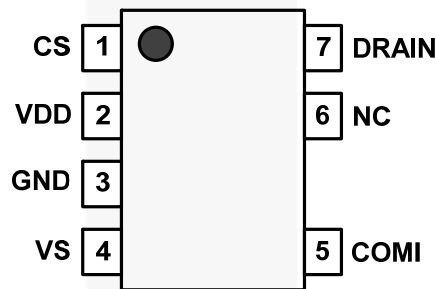

Figure 4. Pin Configuration

Pin Definitions

Pin #	Name	Description
1	CS	Current Sense. This pin connects a current-sense resistor to detect the MOSFET current for the output-current regulation in Constant-Current (CC) regulation.
2	VDD	Power Supply. IC operating current and MOSFET driving current are supplied using this pin.
3	GND	Ground
4	VS	Voltage Sense. This pin detects the output voltage information and discharge time for maximum frequency control and constant current regulation. This pin is connected to an auxiliary winding of the transformer via resistors of the divider.
5	COMI	Constant Current Loop Compensation. This pin is connected to a capacitor between the COMI and GND pins for compensation current loop gain.
6	NC	No Connect
7	DRAIN	Power MOSFET Drain. This pin is the high-voltage power MOSFET drain.

Absolute Maximum Ratings

Stresses exceeding the absolute maximum ratings may damage the device. The device may not function or be operable above the recommended operating conditions and stressing the parts to these levels is not recommended. In addition, extended exposure to stresses above the recommended operating conditions may affect device reliability. The absolute maximum ratings are stress ratings only.

Symbol	Parameter	Min.	Max.	Unit
V _{VDD}	DC Supply Voltage ^(1,2)		30	V
V _{VS}	VS Pin Input Voltage	-0.3	7.0	V
V _{CS}	CS Pin Input Voltage	-0.3	7.0	V
V _{COMI}	COMI Pin Input Voltage	-0.3	7.0	V
I _D	Continuous Drain Current	T _A =25°C, FLS3217M/N	1	A
		T _A =25°C, FLS3247N	4	
I _{DM}	Pulsed Drain Current	FLS3217M/N	4	A
		FLS3247N	16	
I _{AR}	Avalanche Current	FLS3217M/N	1	A
		FLS3247N	4	
P _D	Power Dissipation	SOIC, T _A < 50°C	660	mW
		DIP, T _A < 50°C	1	W
Θ _{JA}	Thermal Resistance (Junction-to-Air)	SOIC, T _A < 50°C	150	°C/W
		DIP, T _A < 50°C	95	
Θ _{JC}	Thermal Resistance (Junction-to-Case)	SOIC, T _A < 50°C	40	°C/W
		DIP, T _A < 50°C	25	
T _J	Maximum Junction Temperature		+150	°C
T _{STG}	Storage Temperature Range	-55	+150	°C
T _L	Lead Temperature (Soldering 10 seconds)		+260	°C
ESD	ESD Capability, Human Body Model		5	V
	ESD Capability, Charged Device Model		2	

Notes:

1. Stresses beyond those listed under Absolute Maximum Ratings may cause permanent damage to the device.
2. All voltage values, except differential voltages, are given with respect to GND pin.

Recommended Operating Conditions

The Recommended Operating Conditions table defines the conditions for actual device operation. Recommended operating conditions are specified to ensure optimal performance to the datasheet specifications. Fairchild does not recommend exceeding them or designing to Absolute Maximum Ratings.

Symbol	Parameter	Min.	Max.	Unit
T _A	Operating Ambient Temperature	-40	125	°C

Electrical Characteristics

Unless otherwise specified, $V_{DD}=15\text{ V}$ and $T_A=25^\circ\text{C}$.

Symbol	Parameter	Condition	Min.	Typ.	Max.	Unit
MOSFET Section						
BV_{DSS}	Drain-Source Breakdown Voltage	$I_D=250\ \mu\text{A}$, $V_{GS}=0\ \text{V}$	700			V
$R_{DS(ON)}$	Static Drain-Source On Resistance	FLS3217M	$I_D=0.5\ \text{A}$, $V_{GS}=10\ \text{V}$	13	16	Ω
		FLS3217N		8.8	11.0	Ω
		FLS3247N	$I_D=1\ \text{A}$, $V_{GS}=10\ \text{V}$	2.4	2.8	Ω
C_{ISS}	Input Capacitance	FLS3217M	$V_{GS}=0\ \text{V}$, $V_{DS}=25\ \text{V}$, $f_S=1\ \text{MHz}$	175	200	pF
		FLS3217N		250		pF
		FLS3247N		435		pF
C_{OSS}	Output Capacitance	FLS3217M	$V_{GS}=0\ \text{V}$, $V_{DS}=25\ \text{V}$, $f_S=1\ \text{MHz}$	23	25	pF
		FLS3217N		25		pF
		FLS3247N		51		pF
V_{DD} Section						
V_{DD-ON}	Turn-On Threshold Voltage		14.5	16.0	17.5	V
V_{DD-OFF}	Turn-Off Threshold Voltage		6.75	7.75	8.75	V
I_{DD-OP}	Operating Current	$V_S=2.4\ \text{V}$, $C_L=\text{MOSFET}$ C_{ISS}	2.85	4.00	5.00	mA
I_{DD-ST}	Startup Current	$V_{DD}=V_{DD-ON} - 0.16\ \text{V}$		2	20	μA
V_{OVP}	V_{DD} Over-Voltage Protection Level		22.0	23.5	25.0	V
Oscillator Section						
f_{MAX-CC}	Maximum Frequency in CC	$V_{DD}=10\ \text{V}$, $20\ \text{V}$	60	65	70	kHz
f_{MIN-CC}	Minimum Frequency in CC	$V_{DD}=10\ \text{V}$, $20\ \text{V}$	21.0	23.5	26.0	kHz
$V_{S_{MAX-CC}}$	VS for Maximum Frequency in CC	Frequency=Maximum Frequency-2 kHz	2.25	2.35	2.45	V
$V_{S_{MIN-CC}}$	VS for Minimum Frequency in CC	Frequency=Minimum Frequency +1 kHz	0.55	0.85	1.15	V
$t_{ON(MAX)}$	Maximum Turn-on Time		12	14	16	μs
Current-Sense Section						
V_{RV}	Reference Voltage		2.475	2.500	2.525	V
V_{CCR}	Variation Test Voltage on CS Pin for Constant Current Regulation	$V_{CS}=0.24\ \text{V}$	2.38	2.43	2.48	V
t_{LEB}	Leading-Edge Blanking Time			300		ns
t_{MIN}	Minimum On Time in CC	$V_{VS}=-0.5\ \text{V}$, $V_{CS}=1.5\ \text{V}$		600		ns
t_{PD}	Propagation Delay to GATE Output		50	100	150	ns
D_{SAW}	Duty Cycle of SAW Limiter			40		%
$t_{DIS-BNK}$	t_{DIS} Blanking Time of VS			1.5		μs
I_{VS-BNK}	VS Current for VS Blanking			100		μA

Continued on the following page...

Electrical Characteristics (Continued)

Unless otherwise specified, $V_{DD}=15\text{ V}$ and $T_A=25^\circ\text{C}$.

Symbol	Parameter	Condition	Min.	Typ.	Max.	Unit
Current-Error-Amplifier Section						
Gm	Transconductance			85		μmho
$I_{\text{COMI-SINK}}$	COMI Sink Current	$V_{\text{EAI}}=3\text{ V}, V_{\text{COMI}}=5\text{ V}$	25		38	μA
$I_{\text{COMI-SOURCE}}$	COMI Source Current	$V_{\text{EAI}}=2\text{ V}, V_{\text{COMI}}=0\text{ V}$	25		38	μA
$V_{\text{COMI-HGH}}$	COMI High Voltage	$V_{\text{EAI}}=2\text{ V}$	4.7			V
$V_{\text{COMI-LOW}}$	COMI Low Voltage	$V_{\text{EAI}}=3\text{ V}$			0.1	V
Over-Current Protection Section						
V_{OCP}	V_{CS} Threshold Voltage for OCP		0.60	0.67	0.74	V
V_{LowOCP}	V_{CS} Threshold Voltage for Low OCP		0.13	0.18	0.23	V
$V_{\text{LowOCP-EN}}$	VS Threshold Voltage to Enable LOW OCP Level			0.40		V
$V_{\text{LowOCP-DIS}}$	VS Threshold Voltage to Disable LOW OCP Level			0.60		V
Over-Temperature-Protection Section						
T_{OTP}	Threshold Temperature for OTP ⁽³⁾		140	150	160	$^\circ\text{C}$
$T_{\text{OTP-HYS}}$	Restart Junction Temperature Hysteresis			10		$^\circ\text{C}$

Note:

- When the over-temperature protection (OTP) is activated, the power system enters Auto-Recovery Mode and output is disabled.

Typical Performance Characteristics

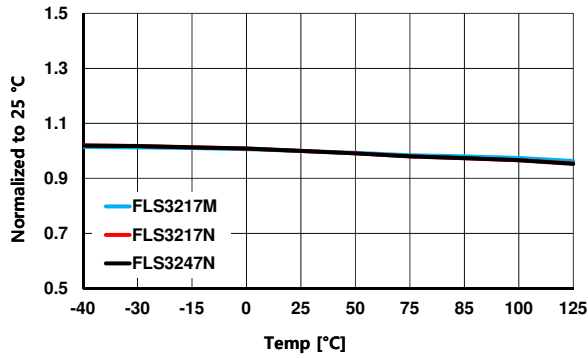

Figure 5. V_{DD-ON} vs. Temperature

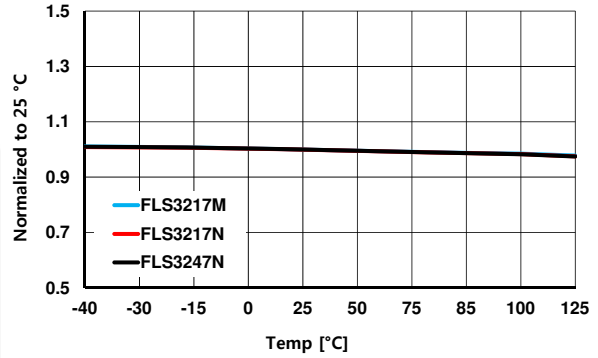

Figure 6. V_{DD-OFF} vs. Temperature

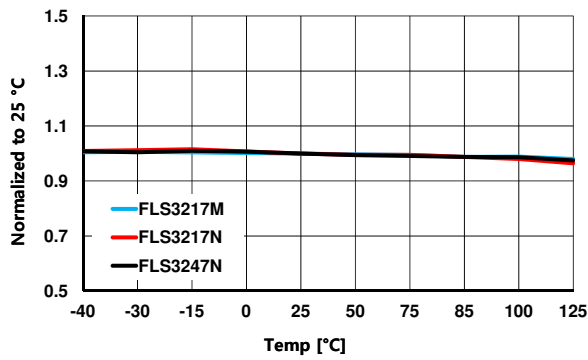

Figure 7. I_{DD-OP} vs. Temperature

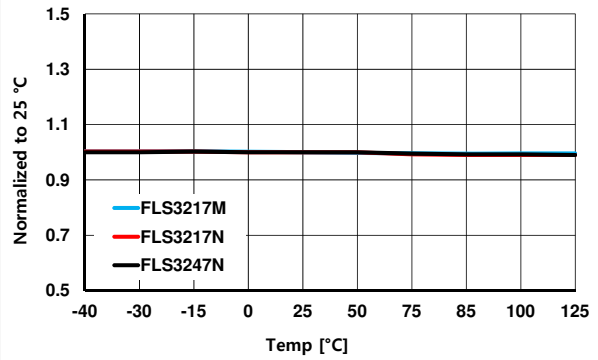

Figure 8. V_{OV} vs. Temperature

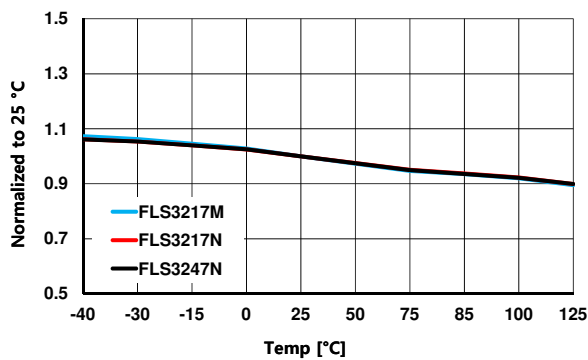

Figure 9. f_{MAX_CC} vs. Temperature

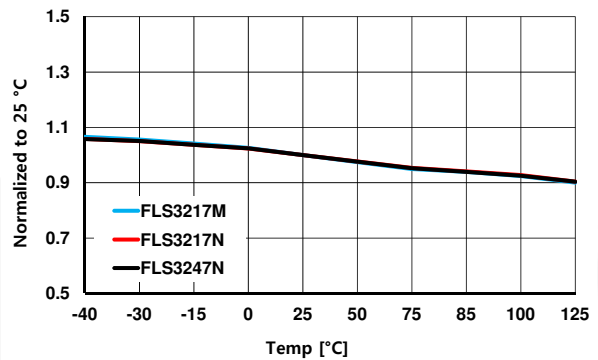

Figure 10. f_{MIN_CC} vs. Temperature

Typical Performance Characteristics (Continued)

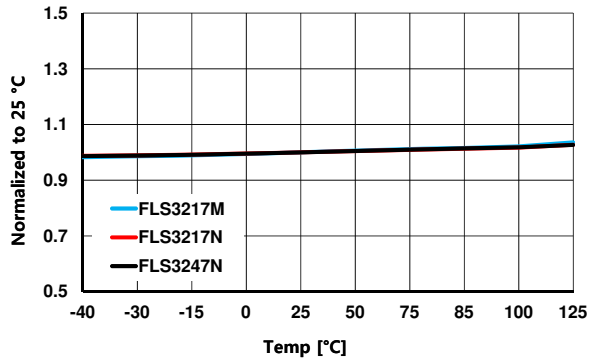

Figure 11. V_{CCR} vs. Temperature

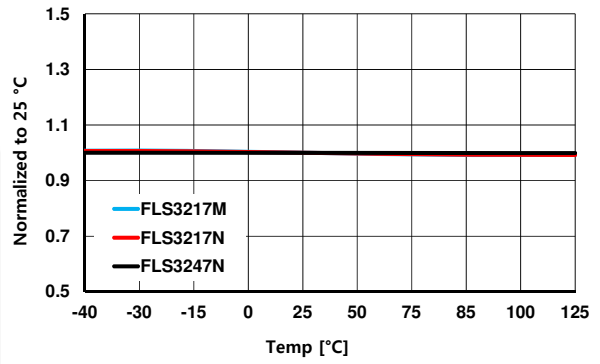

Figure 12. V_{VVR} vs. Temperature

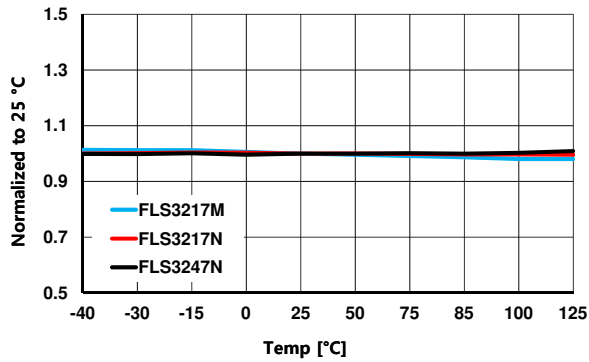

Figure 13. V_{OCP} vs. Temperature

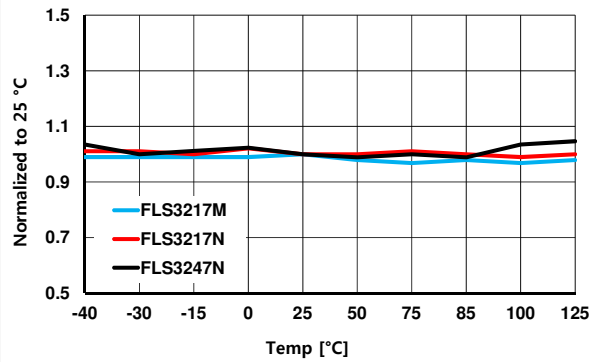

Figure 14. V_{OCP_Low} vs. Temperature

Functional Description

FLS3217 / FLS3247 is an AC-DC PWM controller for LED lighting applications. TRUECURRENT® techniques regulate accurate LED current independent of input voltage, output voltage, and magnetizing inductance variations. The linear frequency control in the oscillator reduces conduction loss and maintains DCM operation in the wide range of output voltage, which implements high power factor correction in a single-stage flyback topology. A variety of protections, such as short/open-LED protection, over-temperature protection, and cycle-by-cycle current limitation stabilize system operation and protect external components.

Startup

Powering at startup is slow due to the low feedback-loop bandwidth in the PFC converter. To increase power during startup, the internal oscillator counts 12ms to define Startup Mode. During Startup Mode, turn-on time is determined by current-mode control with 0.2V voltage limit. Transconductance becomes 14 times bigger, as shown in Figure 15. After Startup Mode, turn-on time is controlled by Voltage Mode, using the COM1 voltage. The error amplifier transconductance is reduced to 85µmho.

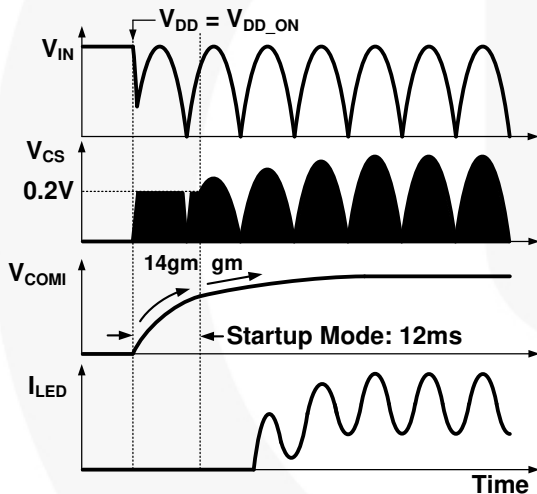

Figure 15. Startup Sequence

Constant Current Regulation

The output current can be estimated using the peak drain current and inductor current discharge time because output current is same as the average of the diode current in steady state. The peak value of the drain current is determined by the CS pin and the inductor discharge time (t_{DIS}) is sensed by t_{DIS} detector. By using three pieces of information (peak drain current, inductor discharging time, and operating switching period); the TRUECURRENT block calculates estimates the output current. The output of the TRUECURRENT calculation is compared with an internal precise reference to generate an error voltage, V_{COM1} , which determines the turn-on time in Voltage-Mode control. With Fairchild's innovative technique, constant current output can be precisely controlled.

Power-Factor Controller (PFC) and Total Harmonic Distortion (THD)

In a conventional boost converter, Boundary Conduction Mode (BCM) is generally used to keep input current in phase with input voltage for Power Factor (PF) and Total Harmonic Distortion (THD). In flyback / buck boost topology, constant turn-on time and constant frequency / Discontinuous Conduction Mode (DCM) can implement high PF and low THD as shown in Figure 16. Constant turn-on time is maintained by the internal error amplifier and a large external capacitor (typically over 1µF) at the COM1 pin. Constant frequency and DCM operation is managed by linear frequency control.

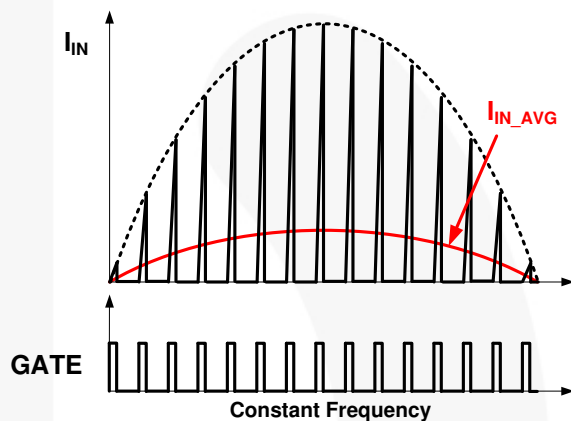

Figure 16. Input Current and Switching

Linear Frequency Control

DCM should be guaranteed for high power factor in flyback topology. To maintain DCM in the wide range of output voltage, frequency is linearly changed by output voltage in linear frequency control. Output voltage is detected by auxiliary winding and a resistive divider connected to the VS pin, as shown in Figure 17.

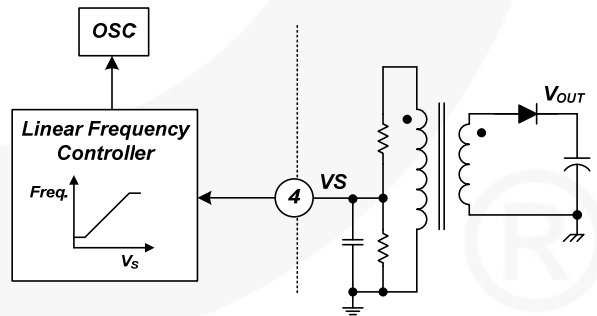

Figure 17. Linear Frequency Control

When the output voltage decreases, the secondary diode conduction time is increased and the linear frequency control lengthens the switching period. This maintains DCM operation in the wide output voltage range, as shown in Figure 18. The frequency control also lowers primary rms current with better power efficiency in full-load condition.

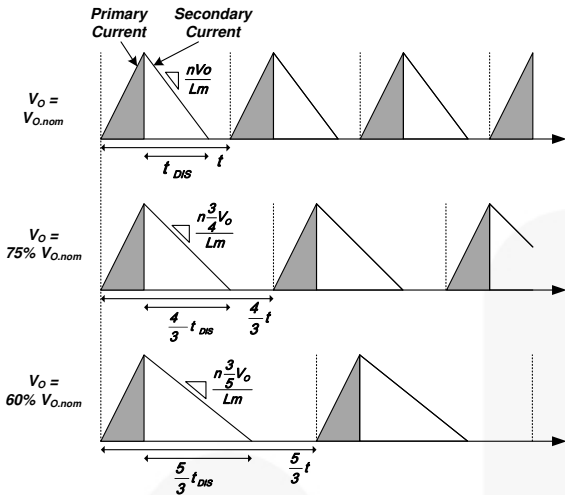

Figure 18. Primary and Secondary Current

BCM Control

The end of secondary diode conduction time is possibly over a switching period set by linear frequency control. In this case, FLS3217 and FLS3247 don't allow CCM and the operation mode changes from DCM to BCM. Therefore, FLS3217 and FLS3247 eliminate sub-harmonic distortion in CCM.

Short-LED Protection

In the event of a short LED condition, the switching MOSFET and secondary diode are usually stressed by the high-power current. However, FLS3217 and FLS3247 change OCP level in short-LED condition. When V_S is lower than 0.4 V, the OCP level lowers to 0.2 V from 0.7 V, as shown in Figure 17. Power is limited and external component current stress is relieved.

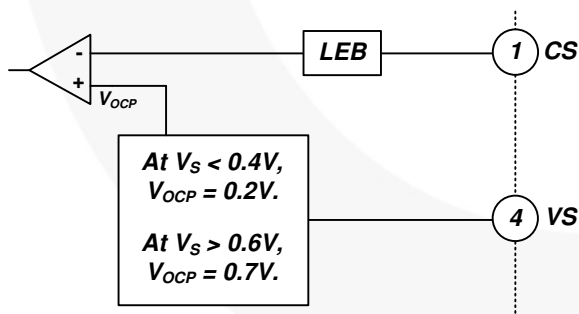

Figure 19. Internal OCP Block

Figure 20 shows operational waveforms at short-LED condition. Output voltage is quickly lowered to 0V after the LED-short event. Then the reflected auxiliary voltage is also 0V, making V_S less than 0.4 V. 0.2 V OCP level limits the primary-side current and V_{DD} "hiccups" up and down in between UVLO hysteresis.

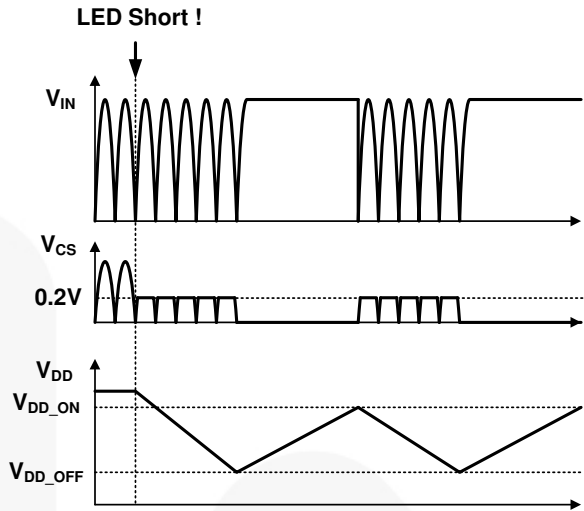

Figure 20. Waveforms at Short-LED Condition

Open LED Protection

FLS3217 and FLS3247 protect external components, such as diode and capacitor, at secondary side in open-LED condition. During switch-off, the V_{DD} capacitor is charged up to the auxiliary winding voltage, which is applied as the reflected output voltage. Because the V_{DD} voltage has output voltage information, the internal voltage comparator on the V_{DD} pin can trigger output over-voltage protection (OVP), as shown in Figure 21. When at least one LED is open-circuited, output load impedance becomes very high and the output capacitor is quickly charged up to $V_{OVP} \times N_s / N_a$. Then switching is shutdown and V_{DD} block goes into "Hiccup Mode" until the open-LED condition is removed, shown in Figure 22.

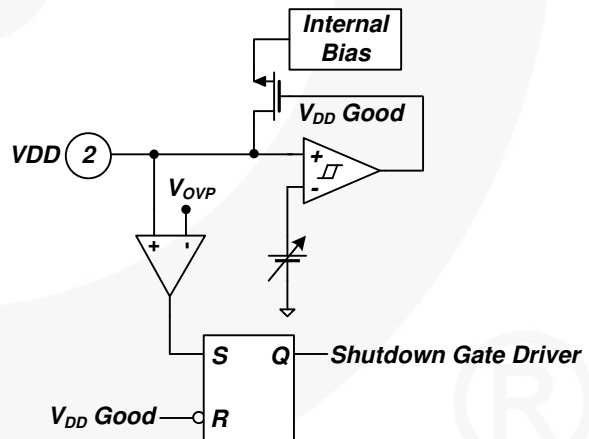

Figure 21. Internal OVP Block

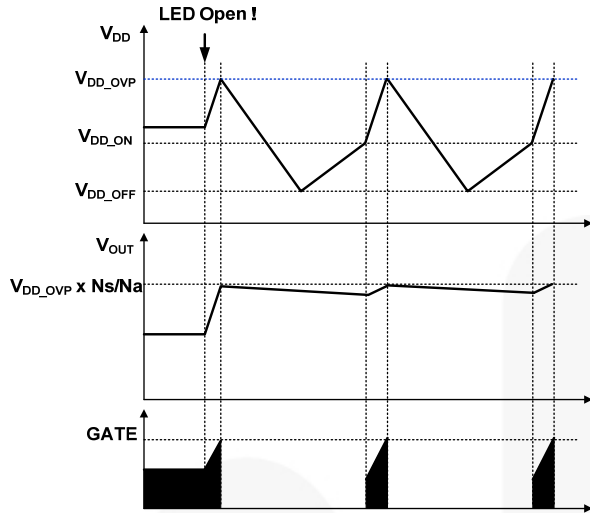

Figure 22. Waveforms at Open-LED Condition

Over-Temperature Protection (OTP)

The built-in temperature-sensing circuit shuts down PWM output once the junction temperature exceeds 150°C. While PWM output is off, VDD gradually drops to the UVLO voltage. Some of the internal circuits are shut down and VDD gradually increases again. When VDD reaches 16 V, all the internal circuits start operating. If the junction temperature is still higher than 140°C, the PWM controller shuts down immediately.

Under-Voltage Lockout (UVLO)

The turn-on and turn-off thresholds are fixed internally at 16 V and 7.5 V, respectively. During startup, the VDD capacitor must be charged to 16 V through the startup resistor, so that the FLS32x7 is enabled. The VDD capacitor supplies VDD until power can be delivered from the auxiliary winding of the main transformer. VDD must not drop below 7.5 V during startup. The UVLO hysteresis window ensures that the VDD capacitor is adequate to supply VDD during startup.

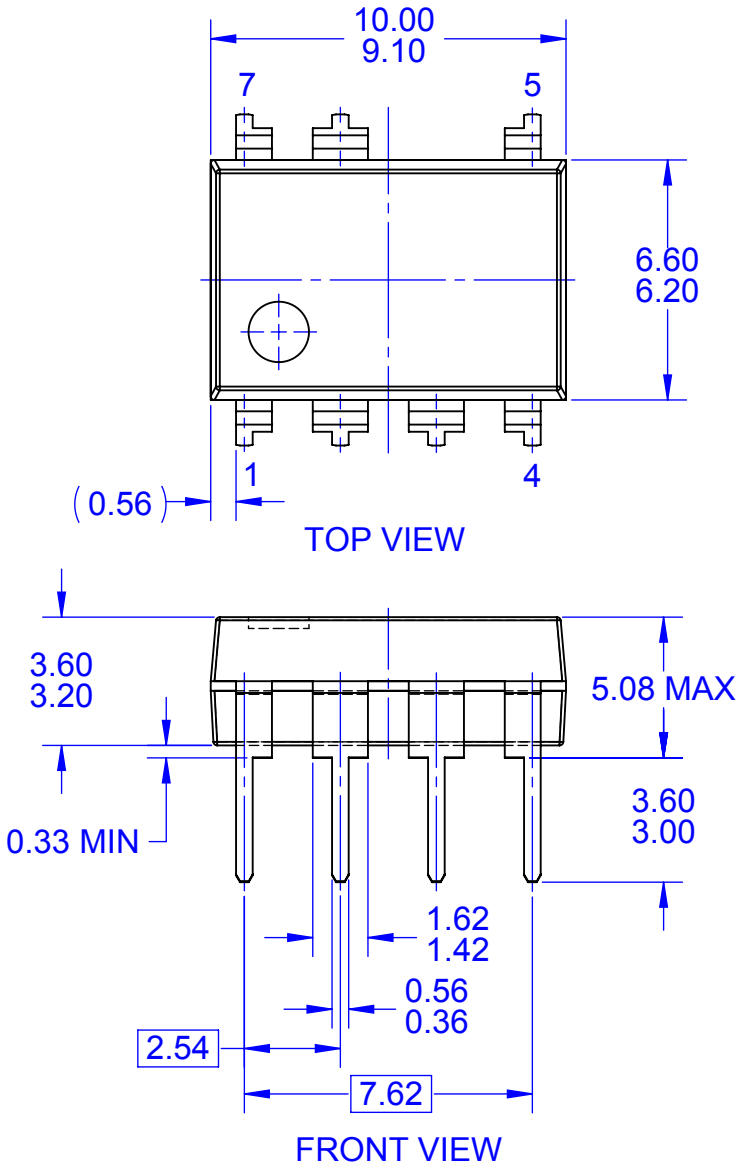

NOTES: UNLESS OTHERWISE SPECIFIED

- A. THIS PACKAGE COMPLIES TO JEDEC MS-001, VARIATION BA, EXCEPT FOR TERMINAL COUNT (7 RATHER THAN 8)
- B. ALL DIMENSIONS ARE IN MILLIMETERS
- C. DIMENSIONS ARE EXCLUSIVE OF BURRS, MOLD FLASH, AND TIE BAR PROTRUSIONS.
- D. DIMENSIONS AND TOLERANCES PER ASME Y14.5M-2009
- E. DRAWING FILENAME: MKT-NA07BArev3



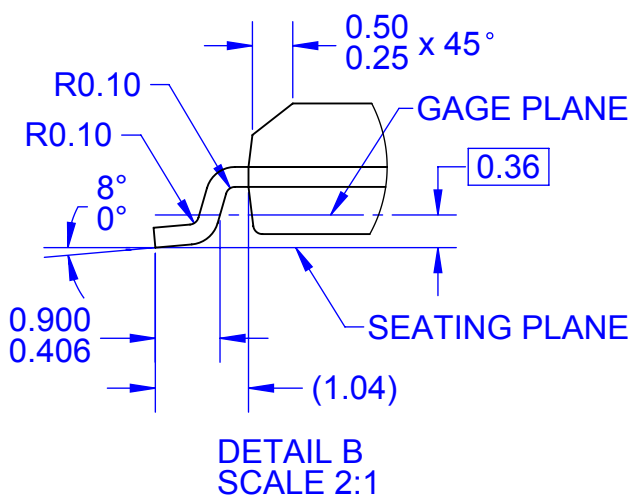
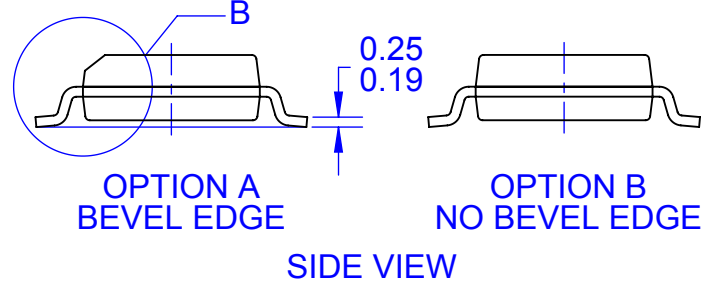
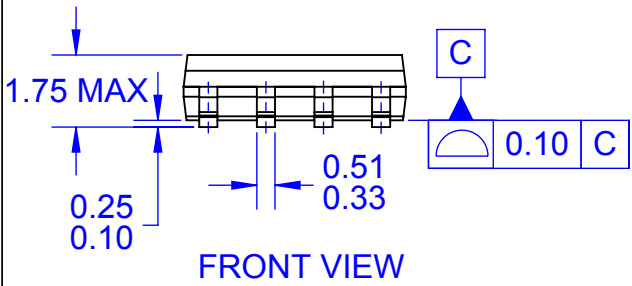
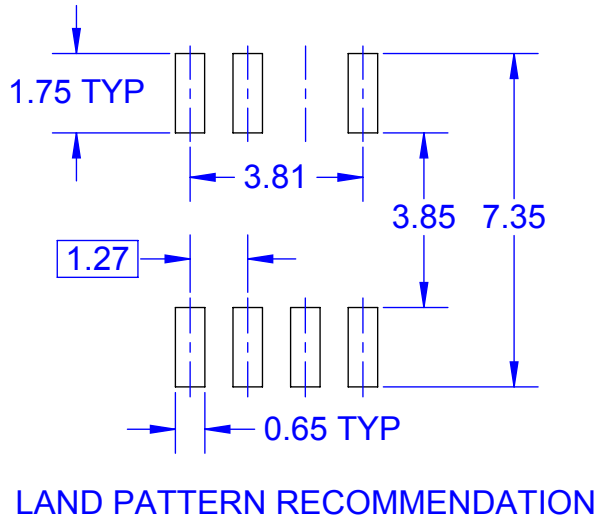
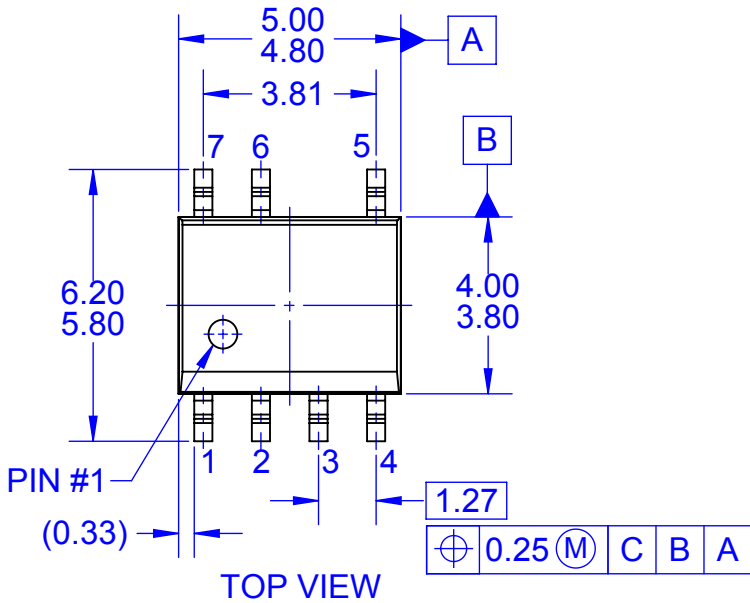

- NOTES:
- A. THIS PACKAGE DOES NOT FULLY CONFORM TO JEDEC MS-012, VARIATION AA
 - B. ALL DIMENSIONS ARE IN MILLIMETERS
 - C. DIMENSIONS DO NOT INCLUDE MOLD FLASH OR BURRS
 - D. DRAWING FILENAME: MKT-M07Brev4



ON Semiconductor and  are trademarks of Semiconductor Components Industries, LLC dba ON Semiconductor or its subsidiaries in the United States and/or other countries. ON Semiconductor owns the rights to a number of patents, trademarks, copyrights, trade secrets, and other intellectual property. A listing of ON Semiconductor's product/patent coverage may be accessed at www.onsemi.com/site/pdf/Patent-Marking.pdf. ON Semiconductor reserves the right to make changes without further notice to any products herein. ON Semiconductor makes no warranty, representation or guarantee regarding the suitability of its products for any particular purpose, nor does ON Semiconductor assume any liability arising out of the application or use of any product or circuit, and specifically disclaims any and all liability, including without limitation special, consequential or incidental damages. Buyer is responsible for its products and applications using ON Semiconductor products, including compliance with all laws, regulations and safety requirements or standards, regardless of any support or applications information provided by ON Semiconductor. "Typical" parameters which may be provided in ON Semiconductor data sheets and/or specifications can and do vary in different applications and actual performance may vary over time. All operating parameters, including "Typicals" must be validated for each customer application by customer's technical experts. ON Semiconductor does not convey any license under its patent rights nor the rights of others. ON Semiconductor products are not designed, intended, or authorized for use as a critical component in life support systems or any FDA Class 3 medical devices or medical devices with a same or similar classification in a foreign jurisdiction or any devices intended for implantation in the human body. Should Buyer purchase or use ON Semiconductor products for any such unintended or unauthorized application, Buyer shall indemnify and hold ON Semiconductor and its officers, employees, subsidiaries, affiliates, and distributors harmless against all claims, costs, damages, and expenses, and reasonable attorney fees arising out of, directly or indirectly, any claim of personal injury or death associated with such unintended or unauthorized use, even if such claim alleges that ON Semiconductor was negligent regarding the design or manufacture of the part. ON Semiconductor is an Equal Opportunity/Affirmative Action Employer. This literature is subject to all applicable copyright laws and is not for resale in any manner.

PUBLICATION ORDERING INFORMATION

LITERATURE FULFILLMENT:

Literature Distribution Center for ON Semiconductor
19521 E. 32nd Pkwy, Aurora, Colorado 80011 USA
Phone: 303-675-2175 or 800-344-3860 Toll Free USA/Canada
Fax: 303-675-2176 or 800-344-3867 Toll Free USA/Canada
Email: orderlit@onsemi.com

N. American Technical Support: 800-282-9855 Toll Free
USA/Canada
Europe, Middle East and Africa Technical Support:
Phone: 421 33 790 2910
Japan Customer Focus Center
Phone: 81-3-5817-1050

ON Semiconductor Website: www.onsemi.com
Order Literature: <http://www.onsemi.com/orderlit>
For additional information, please contact your local
Sales Representative