



Chipsmall Limited consists of a professional team with an average of over 10 year of expertise in the distribution of electronic components. Based in Hongkong, we have already established firm and mutual-benefit business relationships with customers from,Europe,America and south Asia,supplying obsolete and hard-to-find components to meet their specific needs.

With the principle of “Quality Parts,Customers Priority,Honest Operation,and Considerate Service”,our business mainly focus on the distribution of electronic components. Line cards we deal with include Microchip,ALPS,ROHM,Xilinx,Pulse,ON,Everlight and Freescale. Main products comprise IC,Modules,Potentiometer,IC Socket,Relay,Connector.Our parts cover such applications as commercial,industrial, and automotives areas.

We are looking forward to setting up business relationship with you and hope to provide you with the best service and solution. Let us make a better world for our industry!



Contact us

Tel: +86-755-8981 8866 Fax: +86-755-8427 6832

Email & Skype: info@chipsmall.com Web: www.chipsmall.com

Address: A1208, Overseas Decoration Building, #122 Zhenhua RD., Futian, Shenzhen, China



FLUKE®

566/568

Infrared Thermometers

Users Manual

August 2007 Rev. 2, 4/08

© 2007-2008 Fluke Corporation, All rights reserved. Product specifications are subject to change without notice.
All product names are trademarks of their respective companies.

LIMITED WARRANTY AND LIMITATION OF LIABILITY

Each Fluke product is warranted to be free from defects in material and workmanship under normal use and service. The warranty period is two years and begins on the date of shipment. Parts, product repairs, and services are warranted for 90 days. This warranty extends only to the original buyer or end-user customer of a Fluke authorized reseller, and does not apply to fuses, disposable batteries, or to any product which, in Fluke's opinion, has been misused, altered, neglected, contaminated, or damaged by accident or abnormal conditions of operation or handling. Fluke warrants that software will operate substantially in accordance with its functional specifications for 90 days and that it has been properly recorded on non-defective media. Fluke does not warrant that software will be error free or operate without interruption.

Fluke authorized resellers shall extend this warranty on new and unused products to end-user customers only but have no authority to extend a greater or different warranty on behalf of Fluke. Warranty support is available only if product is purchased through a Fluke authorized sales outlet or Buyer has paid the applicable international price. Fluke reserves the right to invoice Buyer for importation costs of repair/replacement parts when product purchased in one country is submitted for repair in another country.

Fluke's warranty obligation is limited, at Fluke's option, to refund of the purchase price, free of charge repair, or replacement of a defective product which is returned to a Fluke authorized service center within the warranty period.

To obtain warranty service, contact your nearest Fluke authorized service center to obtain return authorization information, then send the product to that service center, with a description of the difficulty, postage and insurance prepaid (FOB Destination). Fluke assumes no risk for damage in transit. Following warranty repair, the product will be returned to Buyer, transportation prepaid (FOB Destination). If Fluke determines that failure was caused by neglect, misuse, contamination, alteration, accident, or abnormal condition of operation or handling, including overvoltage failures caused by use outside the product's specified rating, or normal wear and tear of mechanical components, Fluke will provide an estimate of repair costs and obtain authorization before commencing the work. Following repair, the product will be returned to the Buyer transportation prepaid and the Buyer will be billed for the repair and return transportation charges (FOB Shipping Point).

THIS WARRANTY IS BUYER'S SOLE AND EXCLUSIVE REMEDY AND IS IN LIEU OF ALL OTHER WARRANTIES, EXPRESS OR IMPLIED, INCLUDING BUT NOT LIMITED TO ANY IMPLIED WARRANTY OF MERCHANTABILITY OR FITNESS FOR A PARTICULAR PURPOSE. FLUKE SHALL NOT BE LIABLE FOR ANY SPECIAL, INDIRECT, INCIDENTAL OR CONSEQUENTIAL DAMAGES OR LOSSES, INCLUDING LOSS OF DATA, ARISING FROM ANY CAUSE OR THEORY.

Since some countries or states do not allow limitation of the term of an implied warranty, or exclusion or limitation of incidental or consequential damages, the limitations and exclusions of this warranty may not apply to every buyer. If any provision of this Warranty is held invalid or unenforceable by a court or other decision-maker of competent jurisdiction, such holding will not affect the validity or enforceability of any other provision.

Fluke Corporation
P.O. Box 9090
Everett, WA 98206-9090
U.S.A.

Fluke Europe B.V.
P.O. Box 1186
5602 BD Eindhoven
The Netherlands

Table of Contents

Title	Page
Introduction.....	1
Contacting Fluke.....	1
Safety Information.....	2
Symbols and Markings.....	3
Features.....	4
Display Language.....	4
Menu Overview.....	5
Save.....	5
Light.....	6
Memory.....	6
Emissivity Menu.....	6
°C and °F.....	7
Min, Max, Avg, Differential.....	7
Alarm.....	8
Trigger Lock.....	8
Laser.....	8
Setup.....	9
Backlight.....	9
Time/Date.....	9
Language.....	10
Deleting Data.....	10
Deleting All Data.....	10
Deleting Individual Data Records.....	10
How the Thermometers Work.....	11
Operating the Thermometer.....	11
Temperature Measurement.....	11
Locating a Hot or Cold Spot.....	12
Distance and Spot Size.....	13
Field of View.....	14
Emissivity.....	14
HOLD.....	14
Storing Data.....	15
Downloading Data.....	15
External Contact Probe.....	16
Troubleshooting.....	16

Maintenance.....	17
Battery Charge.....	17
Changing the Batteries	17
Cleaning the Lens.....	18
Cleaning the Housing	18
User Replaceable Parts and Accessories.....	18
User Replaceable Parts	18
Accessories.....	18
Recommended Temperature Probes.....	19
Specifications.....	20

List of Tables

Table	Title	Page
1.	Symbols.....	3
2.	Top-Level Menu Description.....	5
3.	Nominal Surface Emissivity.....	7
4.	Troubleshooting	16
5.	Replaceable Parts	18
6.	Recommended Temperature Probes.....	19

List of Figures

Figure	Title	Page
1.	Laser Safety Markings	3
2.	Menu Navigation.....	5
3.	How the Thermometer Works.....	11
4.	Locating a Hot or Cold Spot	12
5.	Distance and Spot Size.....	13
6.	Field of View.....	14
7.	Thermocouple and USB Connections	15
8.	Battery Replacement	17

Infrared Thermometers

Introduction

The 566 and 568 Infrared Thermometers (“the thermometers”) are for non-contact temperature measurement. These thermometers determine an object’s surface temperature by measuring the amount of infrared energy radiated by the object’s surface. The thermometers also support contact-temperature measurement via K-type thermocouple. Note that the Japanese models indicate Celsius only.

Contacting Fluke

To contact Fluke, call one of the following telephone numbers:

- USA: 1-888-44-FLUKE (1-888-443-5853)
- Canada: 1-800-36-FLUKE (1-800-363-5853)
- Europe: +31 402-675-200
- Japan: +81-3-3434-0181
- Singapore: +65-738-5655
- Anywhere in the world: +1-425-446-5500

Or, visit Fluke's Web site at www.fluke.com.

To register your product, visit <http://register.fluke.com>

Safety Information

⚠ Warning

A Warning identifies conditions and actions that pose hazards to the user. To avoid personal injury, follow these guidelines:

- **⚠ Do not point laser directly at eye or indirectly off reflective surfaces.**
- **Replace the batteries as soon as the low-battery indicator appears.**
- **Do not use the thermometer if it operates abnormally. Protection may be impaired. When in doubt, have the thermometer serviced.**
- **Do not operate the thermometer around explosive gas, vapor, or dust.**
- **Do not connect the optional external probe to live electrical circuits.**
- **To avoid a burn hazard or fire, know that reflective objects may be much hotter than the indicated temperature reading.**
- **Do not leave the thermometer on or near objects of high temperature.**
- **Use of controls or adjustments or performance of procedures other than those specified herein may result in hazardous laser radiation exposure.**
- **If the thermometer is used in a manner not specified by the manufacturer, the protection provided by the thermometer may be impaired.**

⚠ Caution









To avoid damaging the thermometer or the equipment under test, protect them from the following:

- **EMF (electro-magnetic fields) from arc welders, induction heaters, etc.**
- **Static electricity**
- **Thermal shock (caused by large or abrupt ambient temperature changes- for highest accuracy, allow 30 minutes for thermometer to stabilize before use).**

Symbols and Markings

Table 1 and Figure 1 show various symbols and safety markings that are on the thermometers and in this manual.

Table 1. Symbols

Symbol	Explanation
	Hazardous voltage. Risk of electrical shock.
	Risk of danger. Important information.
	Warning. Laser.
	Conforms to requirements of European Union and European Free Trade Association (EFTA)
	Celsius
	Fahrenheit
	Battery
	Do not dispose of this product as unsorted municipal waste. Go to Fluke's web site for recycling information.
 沪制01120009号	China metrology certification mark for measuring instruments manufactured in the Peoples Republic of China (PRC).

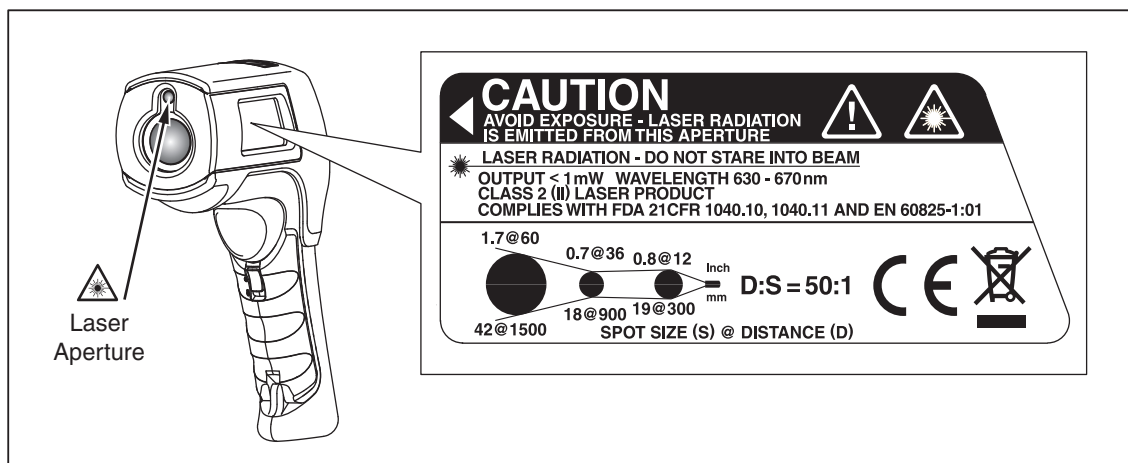

Figure 1. Laser Safety Markings

eyl08b.eps

Features

The thermometers include:

- Single-spot laser sighting
- Infrared and thermocouple temperature display
- 12 or 24 hour clock
- Celsius or Fahrenheit temperature display
- Last reading Hold (20 seconds)
- Multi-language interface
- Adjustable backlit display
- Hard case
- Tripod mount
- Auto off
- MAX, MIN, DIF, AVG temperature displays
- Adjustable emissivity and predefined emissivity table
- High and low alarm
- Data storage and review
- Trigger lock
- Standard miniature K-type thermocouple connector input
- 80PK-1 K-type thermocouple probe
- Two AA batteries
- USB 2.0 computer interface cable (568)
- FlukeView Forms Documenting Software (568)
- Printed *566/568 Getting Started Guide*
- *566/568 Manuals CD*

Display Language

The thermometer display can show data in the following languages:

- English
- Spanish
- French
- German
- Portuguese
- Japanese
- Simplified Chinese

To change the displayed language, refer to “Setup”.

Menu Overview

There are many settings that can be easily changed by using the menu. Figure 2 shows the LCD and menu interface. Selecting the **Menu** softkey advances the menu to the next level. Table 2 is a top-level description of the menu.

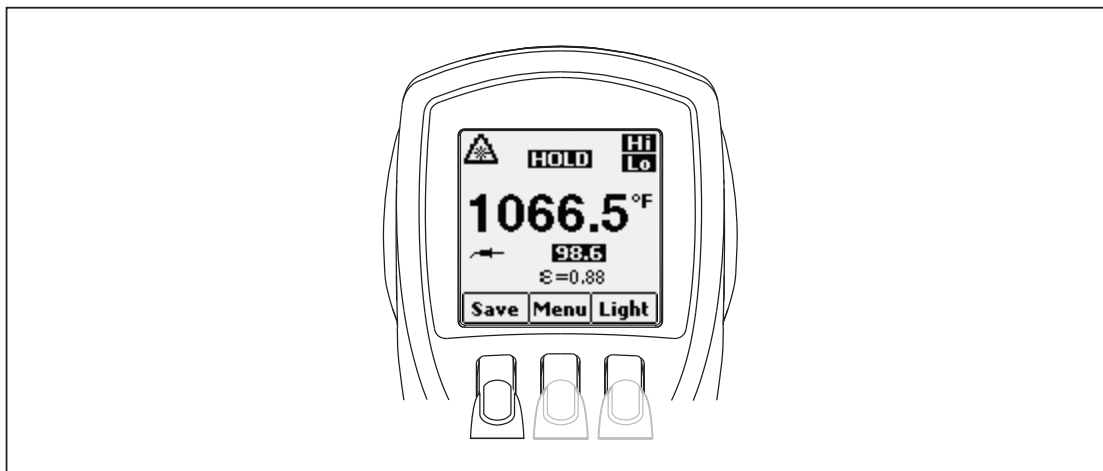

Figure 2. Menu Navigation

eyl01.eps

Table 2. Top-Level Menu Description

Level	Left Softkey	Description	Center Softkey	Right Softkey	Description
1	Save	Save reading to memory	Menu	Light	Adjust backlight brightness
2	Mem	Review/delete memories	Menu	ε	Set emissivity
3	MnMx	Enables Min/Max	Menu	Avg	Enable Avg/Diff
4	°C/°F	Toggle between C and F	Menu	Alarm	Set and enable alarms
5	🔒 (Lock)	Lock the thermometer on	Menu	Laser	Toggle the laser on/off
6	Setup	- Turn off/on backlight - Change Time/Date - Change Language	Menu	-	-

Each menu item and function is explained in greater detail in the following sections.

Save

To save readings:

1. Pull the trigger to take a measurement.
2. Release the trigger to stop taking the measurement.
3. Press the **Save** softkey to enter the Save menu.
4. Press the **Yes** softkey to save the reading.

The reading is assigned a memory location and a time and date stamp.

The reading includes:

- IR temperature
- Thermocouple temperature (if connected)
- Emissivity
- Min/Max/Avg/Dif (if either Min/Max or Avg/Dif is enabled)
- Date/Time

You may also press the **Cancel** softkey to abort saving the reading.

Light

The thermometers are equipped with a backlit display with two brightness levels. The **Light** softkey is used to adjust the backlight brightness. The backlight is on each time the trigger is pulled.

To toggle the backlight brightness, press the **Light** softkey.

The backlight can be disabled using the Setup menu. See “Setup” for more information.

Memory

The thermometers can store measurement records including time, date, emissivity, and measurement record numbers (see “Save” for more information). The 566 can store 20 records and the 568 can store 99.

To access records stored in memory:

1. Press the **Menu** softkey until **Mem** appears as the left softkey function.
2. Press the **Mem** softkey to access the Memory menu. Saved readings can be read.

Emissivity Menu

The Emissivity menu includes a list of pre-defined materials and lists their typical emissivity values, see Table 3. For further information, see “Emissivity”.

Note

Default emissivity is 0.95.

To access the Emissivity menu:

1. Press the **Menu** softkey until **E** (emissivity) appears as the right softkey function.
2. Press the **E** softkey.

The Emissivity list may be accessed by pressing the **Table** softkey or a material’s typical emissivity may be entered manually by pressing the **No.** softkey.

- If the Emissivity table is accessed, a listing of materials and their suggested emissivity is shown.
 1. Use the down arrow to navigate through the list.
 2. Press the **Enter** softkey to choose the desired material.

- To enter an emissivity value manually:
 1. Press the **No.** softkey.
 2. Use the down or up arrow softkey to change the entry. Hold down the up or down arrow softkey to increase the rate of change.
 3. Press the **Done** softkey when finished to return to the main menu.

Table 3. Nominal Surface Emissivity

Material	Value	Material	Value
Default****	0.95	Glass (plate)	0.85
Aluminum*	0.30	Iron*	0.70
Asbestos	0.95	Lead*	0.50
Asphalt	0.95	Oil	0.94
Brass*	0.50	Paint	0.93
Ceramic	0.95	Plastic**	0.95
Concrete	0.95	Rubber	0.95
Copper*	0.60	Sand	0.90
Food - Frozen	0.90	Steel*	0.80
Food - Hot	0.93	Water	0.93
		Wood ***	0.94
* Oxidized ** Opaque, over 20 mils *** Natural **** Factory Setting Highlighted items may also be found in the emissivity table built into the thermometer.			

°C and °F

To toggle between °C (Celsius) and °F (Fahrenheit) measurements, press the **Menu** softkey until °C or °F appears as the left softkey function. Press the corresponding softkey to change between the measurements.

Min, Max, Avg, Differential

The thermometers can measure minimum (MIN), maximum (MAX), average (AVG), or differential (Δ) temperatures each time a reading is taken. These values are not shown if a thermocouple is plugged into the thermometer.

To turn on the Min Max mode:

1. Press the **Menu** softkey until **MnMx** (Min Max) appears as the left softkey function.
2. Press the **MnMx** softkey.

The display shows the present reading, maximum and minimum readings, and the emissivity setting.

To turn on the Avg/Dif mode:

1. Press the **Menu** softkey until **Avg** appears as the right softkey function.

2. Press the **Avg** softkey.

The display shows the present reading, average reading, the differential reading between max and min (designated by Δ), and the emissivity setting.

Note

Min, Max, Avg, and Differential readings are saved as part of the saved data when either Min/Max or Avg/Dif mode is enabled.

Alarm

The thermometers have a programmable high and low alarm to designate high or low readings depending on the thresholds entered. When the alarm level is reached, an alarm will sound and the display will flash orange and white. To set either the high or low alarm:

1. Press the **Menu** softkey until **Alarm** appears as the right softkey function.
2. Press the **Alarm** softkey to access the Alarm menu.
3. Press either the **Hi** or **Lo** softkey, depending on which alarm will be set.
4. Press the **ON** softkey to turn the alarm on.
5. Press the **OFF** softkey to turn the alarm off.
6. Use the **Set** softkey to access the Hi or Lo Alarm Set menu.
7. Use the down or up softkeys to change the alarm setting.
8. Once the desired settings have been entered, press the **Done** softkey.

Trigger Lock

The thermometer trigger can be locked on for continuous measurement. To lock the trigger:

1. Press the **Menu** softkey until the lock symbol (🔒) appears as the left softkey function.
2. Press the 🔒 softkey to lock the trigger. The lock symbol appears on the display to designate a locked trigger. When the trigger is locked, the 🔒 softkey changes to 🔓. Press this softkey to unlock the trigger.

Laser

 **Warning**

To avoid injury, do not point the laser directly at eye or indirectly off reflective surfaces.

The thermometer is equipped with a laser used for aiming purposes only. The laser turns off when the trigger is released.

To enable or disable the laser:

1. Press the **Menu** softkey until **Laser** appears as the right softkey function.
2. Press the **Laser** softkey to enable or disable the laser.  appears on the display when the laser is enabled.

Setup

From the Setup menu, the backlight, time and date, and display language can be changed.

Backlight

In normal use, the backlight is always on. Use this menu to change the backlight setting from on to off. Turning the backlight off conserves battery power.

1. Press the **Menu** softkey until **Setup** appears as the left softkey function.
2. Press the **Setup** softkey.
3. **Backlight** has an indicator next to it. To enter the backlight menu, press the **Enter** softkey.
4. Press the **OFF** softkey to turn the backlight off, press the **ON** softkey to turn it on.
5. Press the **Back** softkey to return to the Setup Menu.

Time/Date

To change the time on the thermometer:

1. Press the **Menu** softkey until **Setup** appears as the left softkey function.
2. Press the **Setup** softkey to enter the Setup menu.
3. Press the down arrow softkey to select **Time/Date**.
4. Press the **Enter** softkey.
5. Select the **Time** softkey.
6. Select the desired time format softkey (**24hr** or **12hr**).
7. Use the up and down softkeys to change the selected hour to the desired hour.
8. Press the **Next** softkey to select the minutes.
9. Use the up and down softkeys to change the selection to the desired minute.
10. When in 12 hour mode, press the **Next** softkey to highlight the **am/pm** parameter.
11. Use the up and down softkey to change to **am** or **pm**.
12. Press the **Done** softkey when finished. The display reverts to the first page of the Time/Date menu.

To change the date on the thermometer:

1. From the main menu, press the **Menu** softkey until **Setup** appears as the left softkey function.
2. Press the **Setup** softkey.
3. Press the down arrow softkey to select **Time/Date**.
4. Press the **Enter** softkey.
5. Press the **Date** softkey.
6. Select the date format: Day/Month/Year (**dmy**) or Month/Day/Year (**mdy**).
7. Use the up and down softkeys to change the selected parameter.
8. Press the **Next** softkey and the arrow softkeys to select the month, date, or year parameters.
9. Use the up and down softkeys to change the selected parameter.

10. Press the **Next** softkey to move through each parameter.
11. Press the **Done** softkey when finished. The display reverts to the beginning of the Time/Date menu.

Language

To change the displayed language:

1. From the main menu, press the **Menu** softkey until **Setup** appears as the left softkey function.
2. Press the **Setup** softkey.
3. Use the down arrow softkey move the indicator to **Language**.
4. Press the **Enter** softkey.
5. Use the down arrow to move the indicator desired language.
6. Press the **Enter** softkey to complete the language selection or press the **Back** softkey to return to the Setup Menu.

Deleting Data

To delete stored data from the thermometer, from the main menu, press the **menu** softkey until **Mem** shows as the left softkey function. The last memory location appears on the display. To access the Delete menu, press the **Delete** softkey. From here, either all of the thermometer memory can be deleted or individual records.

Deleting All Data

To delete all of the records, press the **All** softkey. At the confirmation screen, press the **Yes** softkey.

Deleting Individual Data Records

To delete individual records, press the **View** softkey and then use the down and up arrow softkeys to access the desired record. Once the desired record is shown, press the **Yes** softkey to delete the record. To cancel data deletion, pull the trigger.

How the Thermometers Work

Infrared thermometers measure the surface temperature of an object. The thermometer's optics sense emitted, reflected, and transmitted energy, which is collected and focused onto a detector. The unit's electronics translate the signal into a temperature reading which the unit displays (see Figure 3).

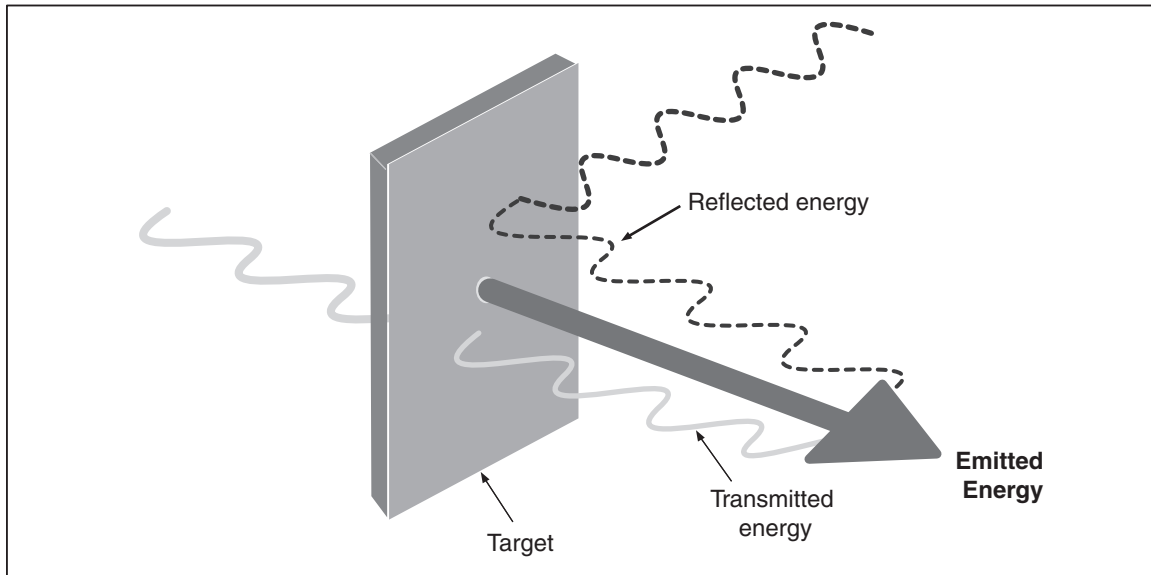

Figure 3. How the Thermometer Works

eyl002f.eps

Operating the Thermometer

Temperature Measurement

To measure temperature, point the thermometer at an object and pull the trigger. You can use the laser pointer to help aim the thermometer. You may also insert the K-type thermocouple probe for contact measurement. Be sure to consider distance-to-spot size ratio and field of view (see “Distance and Spot Size” and “Field of View”). The temperature appears on the display.

Note

The laser is used for aiming purposes only and is not related to temperature measurement.

The thermometer features an auto off function that automatically powers down the thermometer after 20 seconds of inactivity. To turn the thermometer on, pull the trigger.

Locating a Hot or Cold Spot

To find a hot or cold spot, aim the thermometer outside the desired area. Then, slowly scan across the area with an up and down motion until you locate the hot or cold spot (see Figure 4).

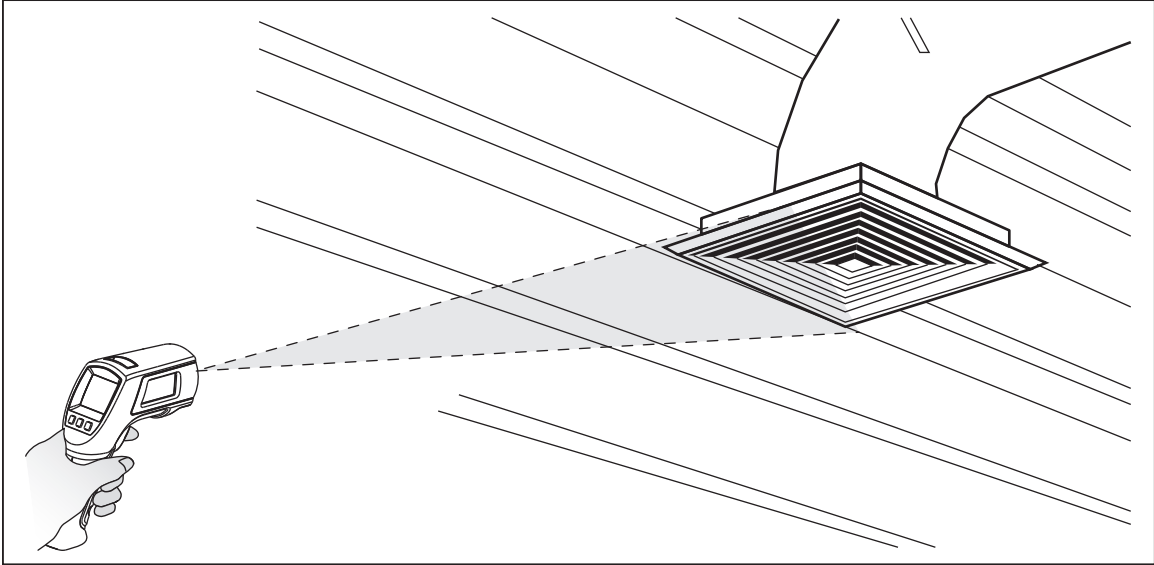
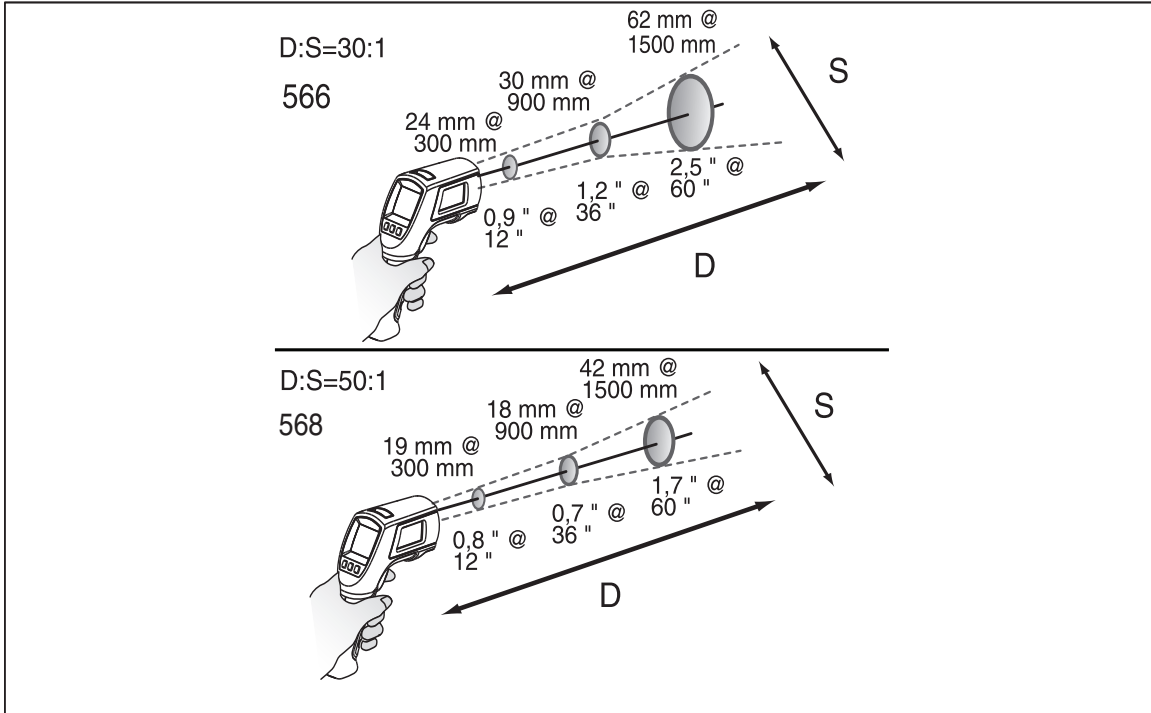

Figure 4. Locating a Hot or Cold Spot

ey107.eps

Distance and Spot Size

As the distance (D) from the object being measured increases, the spot size (S) of the area measured by the unit becomes larger. The relationship between distance and spot size (D:S) for each unit is shown in Figure 5. The spot sizes indicate 90 % encircled energy.



eyl06.eps

Figure 5. Distance and Spot Size

Field of View

For accurate measurements, make sure that the target is larger than the unit's spot size. The smaller the target, the closer you should be to it (see Figure 6).

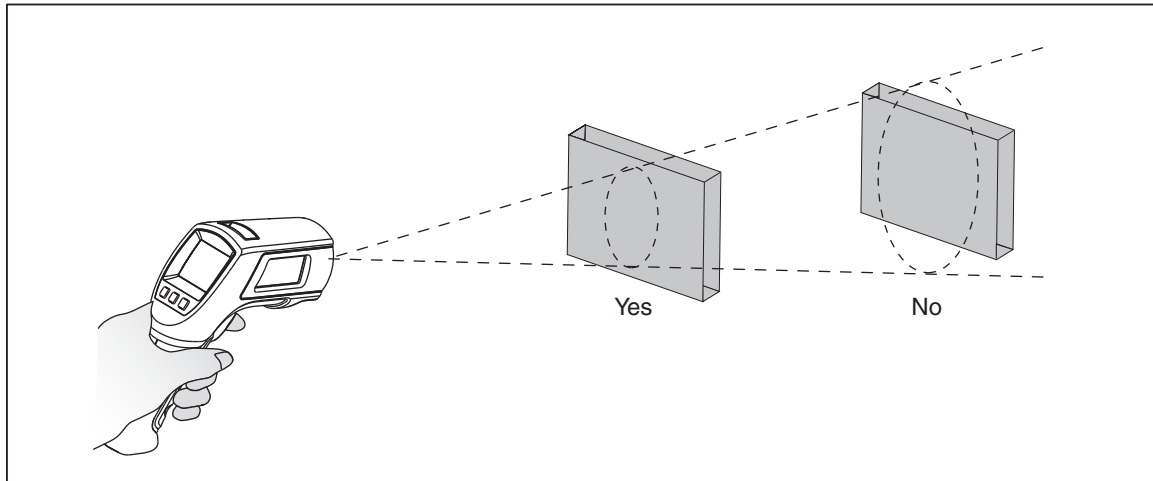

Figure 6. Field of View

eyl05.eps

Emissivity

Emissivity describes the energy-emitting characteristics of materials. Most organic materials and painted or oxidized surfaces have an emissivity of approximately 0.95, the default setting for the thermometer.

To compensate for inaccurate readings that may result from measuring shiny metal surfaces, you can cover the surface to be measured with electrical tape or flat black paint (<148 °C/300 °F) with emissivity set to 0.95. Allow time for the tape or paint to reach the same temperature as the surface beneath it. Measure the temperature of the tape or painted surface.

If you cannot paint or use tape, then you can improve the accuracy of your measurements by either numerically adjusting emissivity or by using the Emissivity Menu to access a table of some common materials. The thermometers have numerically adjustable emissivity from 0.10 to 1.00 that can be used in conjunction with the emissivities in Table 3. Also, the thermometers have a built-in table of the most common materials that can be set from the Emissivity Menu. The built-in values are indicated in Table 3.

HOLD

The display retains its last infrared measurement for twenty seconds when the trigger is released, with **HOLD** appearing on the display. With the probe inserted, the contact thermometer remains on. To freeze the infrared temperature when a probe is not inserted, release the trigger until **HOLD** appears on the display.

Storing Data

The 566 thermometer can store up to 20 data records. The 568 thermometer can store up to 99 data records. The following information is stored in each record:

- Record number
- IR and probe temperature in °F or °C
- Date/Time
- Emissivity
- Max/Min/Avg/Dif Temperature (if enabled)

For more information, see “Save”.

Downloading Data

The stored data of the 568 can be downloaded to a personal computer (PC) via the included USB cable and the included FlukeView® Forms Documenting Software. See the FlukeView® Forms documentation for details. The USB input ② is located on the top of the thermometer next to the external probe input ① (see Figure 7).

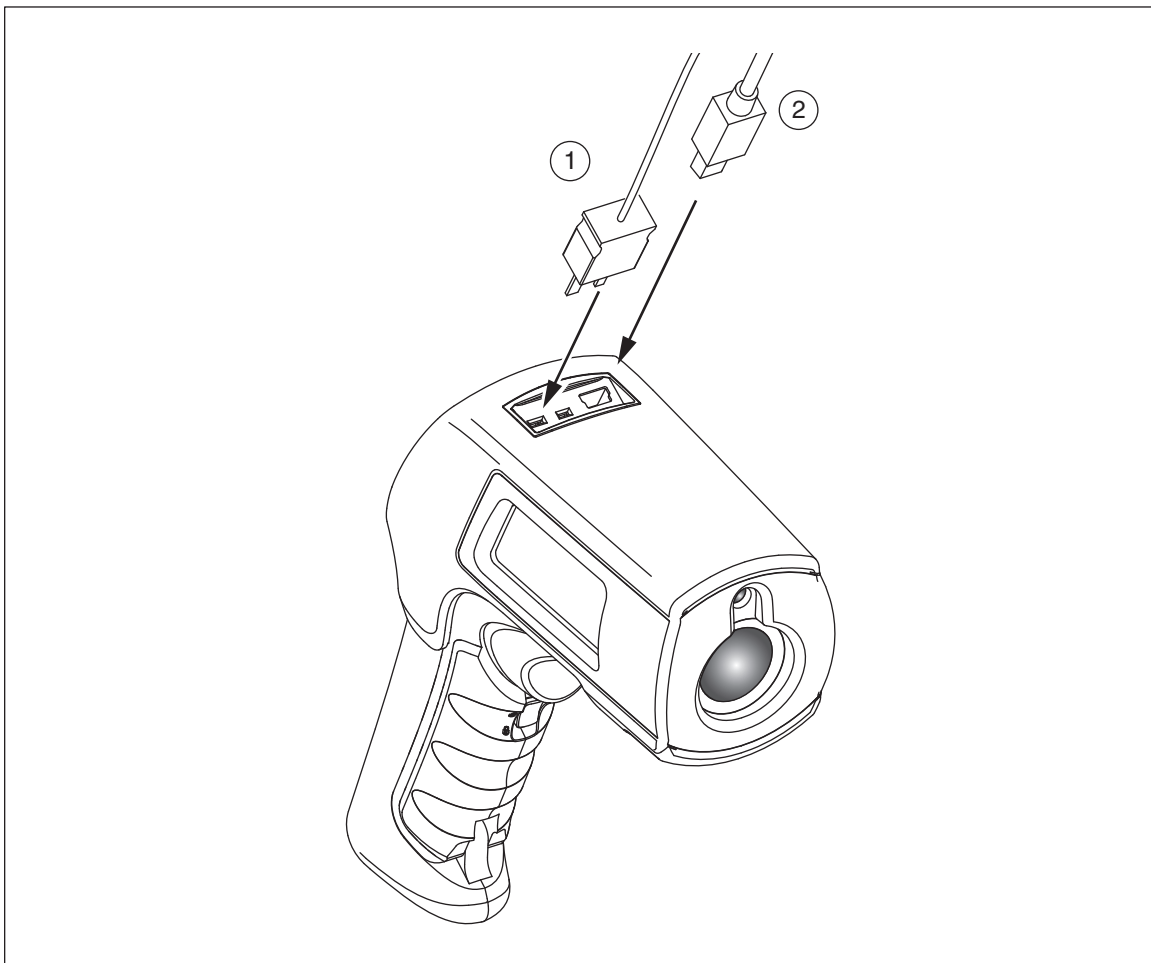

Figure 7. Thermocouple and USB Connections

eyl03.eps

External Contact Probe

Warning

To avoid electrical shock or personal injury, do not connect the external contact probe to live electrical circuits.

The thermometers come with a bead K-type thermocouple probe. The probes attach to the thermometers via the probe input located on the top of the thermometer (see Figure 7).

With the probe installed, the probe symbol () appears on the display. The probe can be used simultaneously while the thermometer is taking non-contact measurements. The probe readings are shown below the non-contact measurements. The thermometer will stay on when there is a probe inserted. When used with a personal computer and FlukeView Forms (568 only), the auto off feature is disabled.

Troubleshooting

Use the following table to remedy possible problems when using the thermometer.

Table 4. Troubleshooting

Symptom	Cause	Action
--- (on display)	Target temperature is over or under range.	Select target within specifications
	Low batteries	Replace Batteries
Blank display	Thermometer is asleep Possible dead batteries	Pull trigger Replace batteries
Laser does not work	Low or dead batteries Ambient temperature is above 40 °C (104 °F)	Replace batteries Use in area with lower ambient temperature
Failed communication via USB	Unit is off FlukeView Forms is not running	Pull the trigger Start FlukeView Forms
Inaccuracy	Possible incorrect emissivity setting, field of view, or spot size	See “Emissivity”, “Field of View” and “Distance and Spot Size” sections.
Settings such as emissivity, date/time, F/C, and saved data lost	Battery dead or not replaced in <1 minute of removal	Reset settings. Replace batteries as soon as low battery indicated; Exchange the batteries within one minute of removal. Refer to “Changing the Batteries”.

Maintenance

Battery Charge

Use the battery charge symbols to gauge the approximate level of charge left on the batteries.

Notes

When in low battery mode, the thermometer does not store values. “Err” appears on the display if attempted.

-  Batteries are at 5%. Before taking further readings, the batteries must be changed.

Changing the Batteries

Note

The batteries should be replaced in less than one minute after removal to avoid manually re-initializing the thermometer clock and date.

To install or change the two AA batteries (see Figure 8):

1. Slide the locking tab on the battery door to the “unlock” position and then open the handle.
2. Insert the batteries noting their correct polarity.
3. Close and lock the handle.

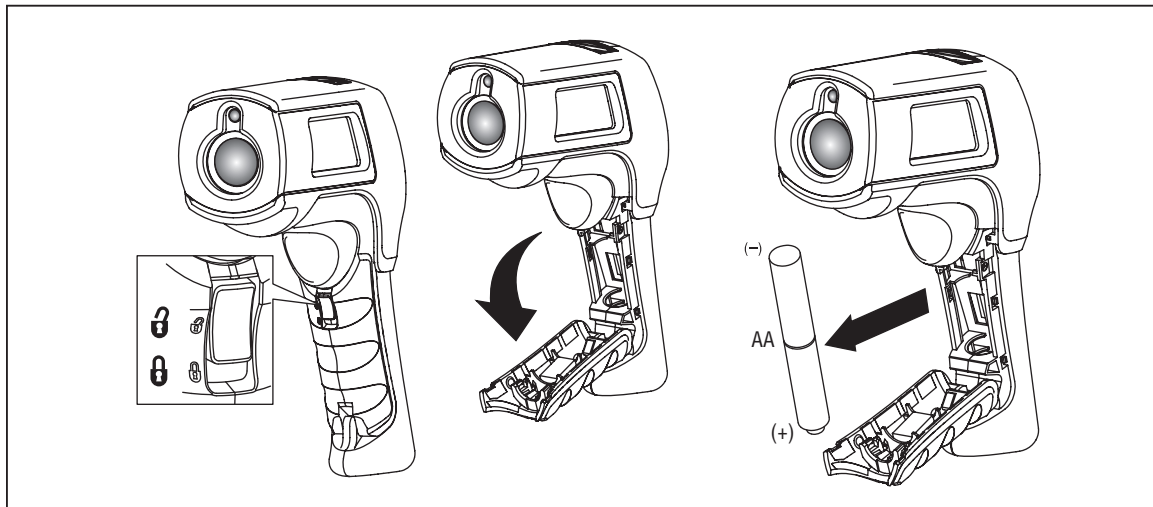

Figure 8. Battery Replacement

ey104.eps