



Chipsmall Limited consists of a professional team with an average of over 10 year of expertise in the distribution of electronic components. Based in Hongkong, we have already established firm and mutual-benefit business relationships with customers from,Europe,America and south Asia,supplying obsolete and hard-to-find components to meet their specific needs.

With the principle of “Quality Parts,Customers Priority,Honest Operation,and Considerate Service”,our business mainly focus on the distribution of electronic components. Line cards we deal with include Microchip,ALPS,ROHM,Xilinx,Pulse,ON,Everlight and Freescale. Main products comprise IC,Modules,Potentiometer,IC Socket,Relay,Connector.Our parts cover such applications as commercial,industrial, and automotives areas.

We are looking forward to setting up business relationship with you and hope to provide you with the best service and solution. Let us make a better world for our industry!



## Contact us

Tel: +86-755-8981 8866 Fax: +86-755-8427 6832

Email & Skype: info@chipsmall.com Web: www.chipsmall.com

Address: A1208, Overseas Decoration Building, #122 Zhenhua RD., Futian, Shenzhen, China



# Cypress FM4 Graphics Controller MCU Starter Kit



The Cypress S6E2DH series graphics controller MCU starter kit provides an easy to use, cost-effective solution to evaluate an ARM® Cortex®- M4 based microcontroller that incorporates a dedicated hardware graphics engine allowing rich display images. The board comes complete with WQVGA TFT display with a touch sensor and on-board CMSIS-DAP enabling the user to connect directly to a PC and begin development. In addition to the evaluation board, the Cypress solution includes a free-of-charge graphics authoring tool and low-level libraries for the graphics engine.

Cypress's S6E2DH MCU is ideal for embedded applications with TFT displays such as home appliances, multi-function printers, industrial equipment, electronic musical instruments and security systems.

## Features

- Cypress FM4 S6E2DH MCU
- CMSIS-DAP JTAG adapter
- USB-Device (Type-B connector)
- WQVGA TFT Panel with touch
- 512MB Spansion HyperFlash™ memory for image storage
- 128MB SDRAM for external VRAM
- I<sup>2</sup>S connection to codec
- SD card interface

**Part number: FM4-176L-S6E2DH**

## MCU block diagram / features

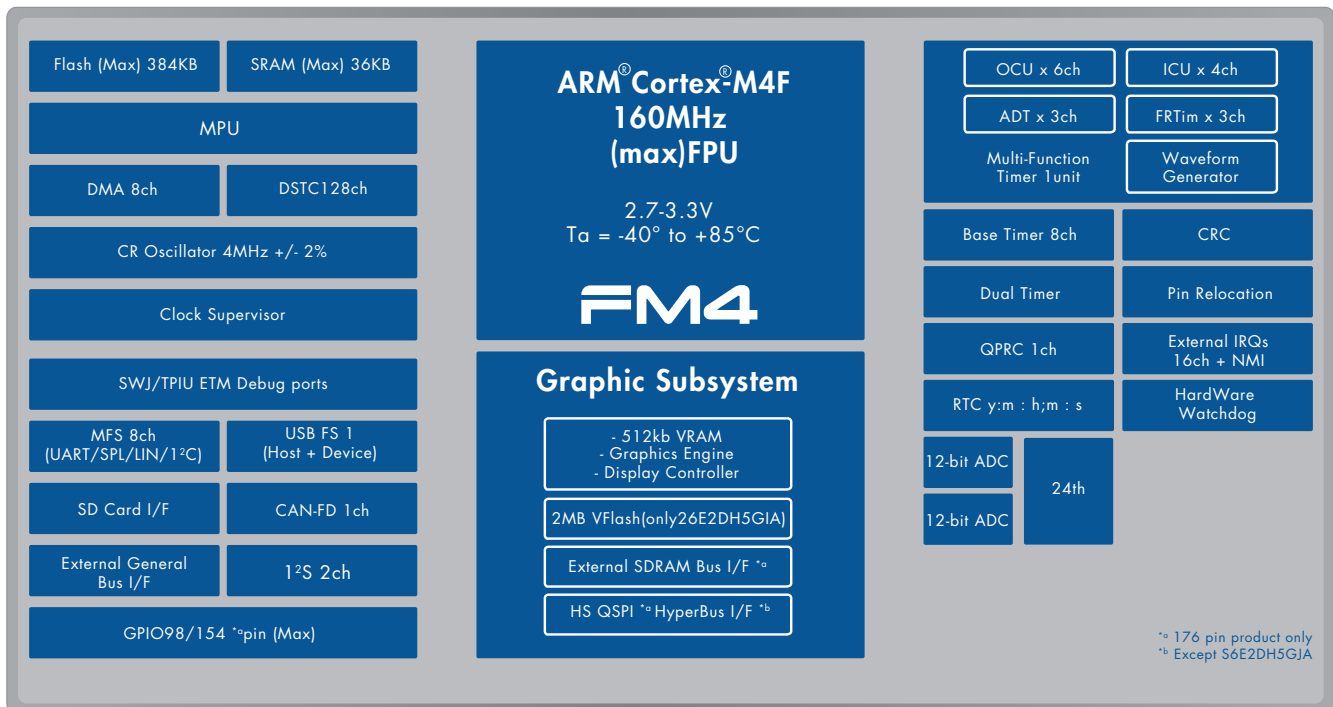

<sup>a</sup> 176 pin product only  
<sup>b</sup> Except S6E2DH5GJA



## Starter kit block diagram

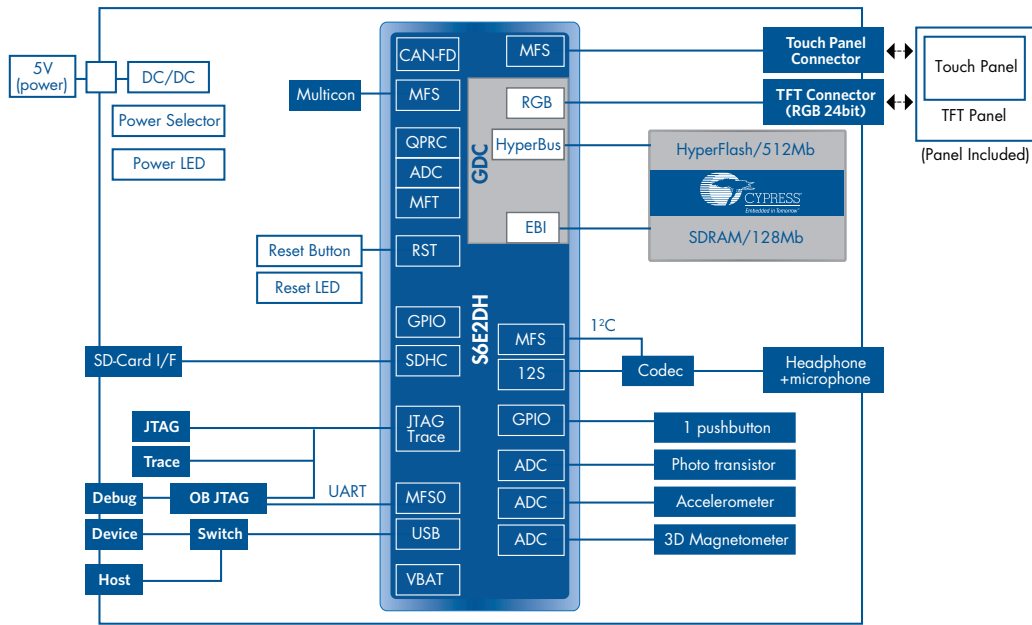

## Development environment / evaluation board

Graphics Software Development environment

Development Tools  
ARM (KEIL) / IAR SYSTEMS

GDC Software Architecture

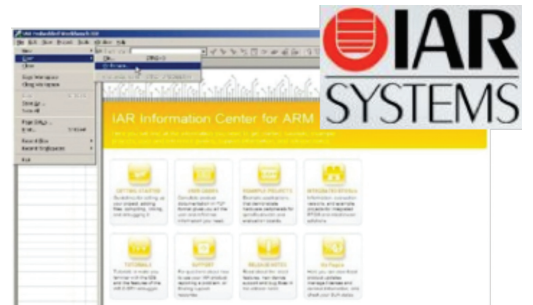
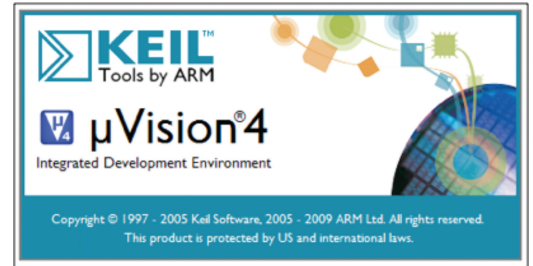
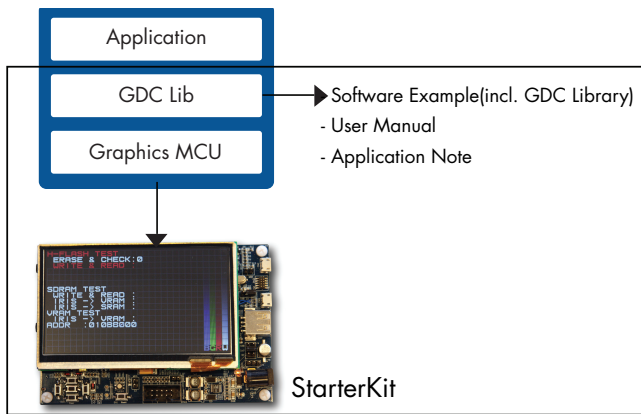

Note: This document may be revised by subsequent versions or modifications due to changes in technical specifications.

### Cypress Semiconductor Corporation

198 Champion Court, San Jose CA 95134  
 phone +1 408.943.2600 fax +1 408.943.6848  
 toll free +1 800.858.1810 (U.S. only) Press "1" to reach your local sales representative

© 2015-2016 Cypress Semiconductor Corporation. All rights reserved. All other trademarks are the property of their respective owners.  
 Doc# 002-06956 Rev\*A

