



Chipsmall Limited consists of a professional team with an average of over 10 year of expertise in the distribution of electronic components. Based in Hongkong, we have already established firm and mutual-benefit business relationships with customers from,Europe,America and south Asia,supplying obsolete and hard-to-find components to meet their specific needs.

With the principle of "Quality Parts,Customers Priority,Honest Operation,and Considerate Service",our business mainly focus on the distribution of electronic components. Line cards we deal with include Microchip,ALPS,ROHM,Xilinx,Pulse,ON,Everlight and Freescale. Main products comprise IC,Modules,Potentiometer,IC Socket,Relay,Connector.Our parts cover such applications as commercial,industrial, and automotives areas.

We are looking forward to setting up business relationship with you and hope to provide you with the best service and solution. Let us make a better world for our industry!



Contact us

Tel: +86-755-8981 8866 Fax: +86-755-8427 6832

Email & Skype: info@chipsmall.com Web: www.chipsmall.com

Address: A1208, Overseas Decoration Building, #122 Zhenhua RD., Futian, Shenzhen, China





CYPRESS[®]

Embedded in Tomorrow[™]

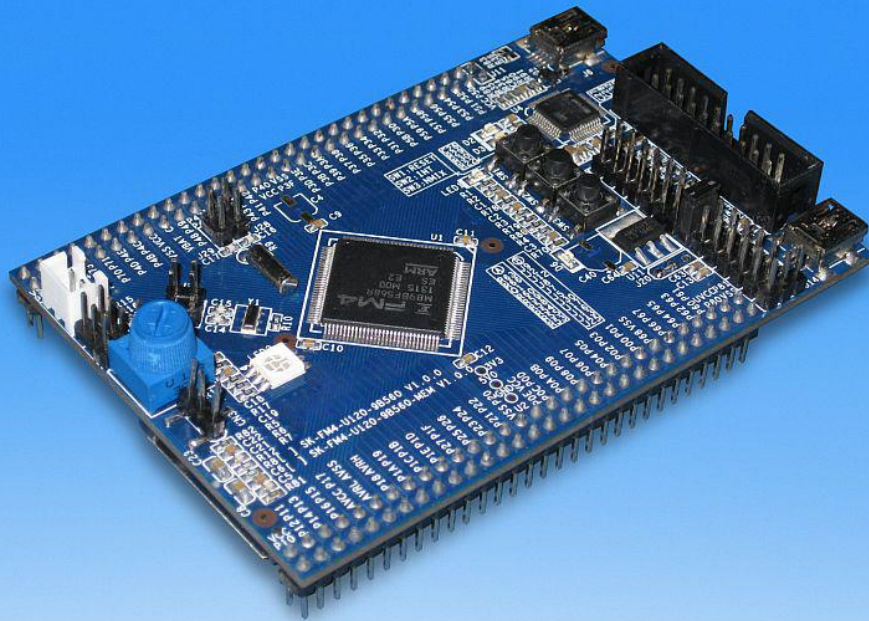

Starter kit User Guide

SK-FM4-U120-9B560

SK-FM4-U120-9B560-MEM

Hardware V1.1 / Documentation V1.7



Document Number: 002-09878 Rev. *A

Warranty and Disclaimer



© Cypress Semiconductor Corporation, 2015-2016. This document is the property of Cypress Semiconductor Corporation and its subsidiaries, including Spansion LLC (“Cypress”). This document, including any software or firmware included or referenced in this document (“Software”), is owned by Cypress under the intellectual property laws and treaties of the United States and other countries worldwide. Cypress reserves all rights under such laws and treaties and does not, except as specifically stated in this paragraph, grant any license under its patents, copyrights, trademarks, or other intellectual property rights. If the Software is not accompanied by a license agreement and you do not otherwise have a written agreement with Cypress governing the use of the Software, then Cypress hereby grants you a personal, non-exclusive, nontransferable license (without the right to sublicense) (1) under its copyright rights in the Software (a) for Software provided in source code form, to modify and reproduce the Software solely for use with Cypress hardware products, only internally within your organization, and (b) to distribute the Software in binary code form externally to end users (either directly or indirectly through resellers and distributors), solely for use on Cypress hardware product units, and (2) under those claims of Cypress’s patents that are infringed by the Software (as provided by Cypress, unmodified) to make, use, distribute, and import the Software solely for use with Cypress hardware products. Any other use, reproduction, modification, translation, or compilation of the Software is prohibited.

TO THE EXTENT PERMITTED BY APPLICABLE LAW, CYPRESS MAKES NO WARRANTY OF ANY KIND, EXPRESS OR IMPLIED, WITH REGARD TO THIS DOCUMENT OR ANY SOFTWARE OR ACCOMPANYING HARDWARE, INCLUDING, BUT NOT LIMITED TO, THE IMPLIED WARRANTIES OF MERCHANTABILITY AND FITNESS FOR A PARTICULAR PURPOSE. To the extent permitted by applicable law, Cypress reserves the right to make changes to this document without further notice. Cypress does not assume any liability arising out of the application or use of any product or circuit described in this document. Any information provided in this document, including any sample design information or programming code, is provided only for reference purposes. It is the responsibility of the user of this document to properly design, program, and test the functionality and safety of any application made of this information and any resulting product. Cypress products are not designed, intended, or authorized for use as critical components in systems designed or intended for the operation of weapons, weapons systems, nuclear installations, life-support devices or systems, other medical devices or systems (including resuscitation equipment and surgical implants), pollution control or hazardous substances management, or other uses where the failure of the device or system could cause personal injury, death, or property damage (“Unintended Uses”). A critical component is any component of a device or system whose failure to perform can be reasonably expected to cause the failure of the device or system, or to affect its safety or effectiveness. Cypress is not liable, in whole or in part, and you shall and hereby do release Cypress from any claim, damage, or other liability arising from or related to all Unintended Uses of Cypress products. You shall indemnify and hold Cypress harmless from and against all claims, costs, damages, and other liabilities, including claims for personal injury or death, arising from or related to any Unintended Uses of Cypress products.

Cypress, the Cypress logo, Spansion, the Spansion logo, and combinations thereof, WICED, PSoC, CapSense, EZ-USB, F-RAM, and Traveo are trademarks or registered trademarks of Cypress in the United States and other countries. For a more complete list of Cypress trademarks, visit cypress.com. Other names and brands may be claimed as property of their respective owners.

- For your convenience this user guide includes external links that simplify installing of drivers, software utilities, and quick jumps to documentation.
- Some PDF viewer do not allow access to external content by links because of security reasons.
- A viewer called “PDF XChange” is provided in the software package of this starter kit. It’s use is free of charge and no additional installation is required.
- Launching “start.bat” opens this user guide in the PDF XChange viewer.
- Please ensure you have copied the complete software package related to this starter kit in order to use and run the links and examples given on the next pages.
- Please contact the [Cypress Support](#) in case of any question.

- [MCU Features](#), [Board Features](#) & [Contents](#)
- [Please check jumper setting](#) / [Test it by a GUI](#)
- [The Hardware](#) / [Pin Overview](#)
- [The Jumper Table](#) / [Jumper Default](#)
- [Board Power](#)
- [Software Examples & Tools](#)
- [Flash Programming](#)
- [JTAG / CMSIS-DAP](#)
- [IAR-Embedded Workbench](#)
- [KEIL μVision](#)
- [Contacts](#) & [More](#)

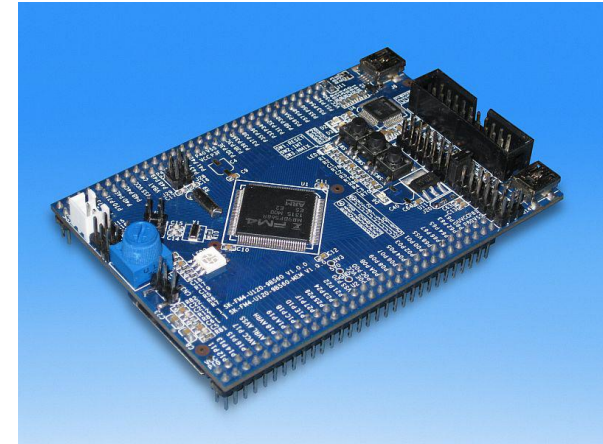

■ [Additional documents](#)

- [Schematic](#)
- [Factsheet](#)
- [Data sheet MB9B560R Series](#) and [Errata](#)
- [Peripheral Manual](#) and [Errata](#)
- [Peripheral Manual \(Timer Part\)](#) and [Errata](#)
- [Peripheral Manual \(Analog Part\)](#)
- [Peripheral Manual \(Communication Part\)](#) and [Errata](#)
- [Flash Programming Manual](#) and [Errata](#)

Please visit www.cypress.com to find latest releases of the above mentioned documents.

Features of the microcontroller

- The SK-FM4-U120-9B560 and SK-FM4-U120-9B560-MEM are based on the Cypress ARM[®] Cortex[®]-M4 device MB9BF568R
- The MB9B560R Series includes the following features:
 - Up to 1 MByte Flash Memory and 32 KByte Work Flash Memory
 - Up to 128 KByte RAM
 - Up to 160MHz clock
 - Up to 2 CAN controller 2.0A/B
 - Up to 8 UART / LIN / SPI / I²C interfaces
 - USB-Host/-Device interface
 - SD-Card interface
 - Three 12 bit ADCs, up to 24 channels
 - Two 12 bit DACs
 - Up to 16 channel external interrupts
 - Two Multifunction timer with waveform generator, e.g. Motor control
 - Timers (ICUs, OCUs, PPGs, others)

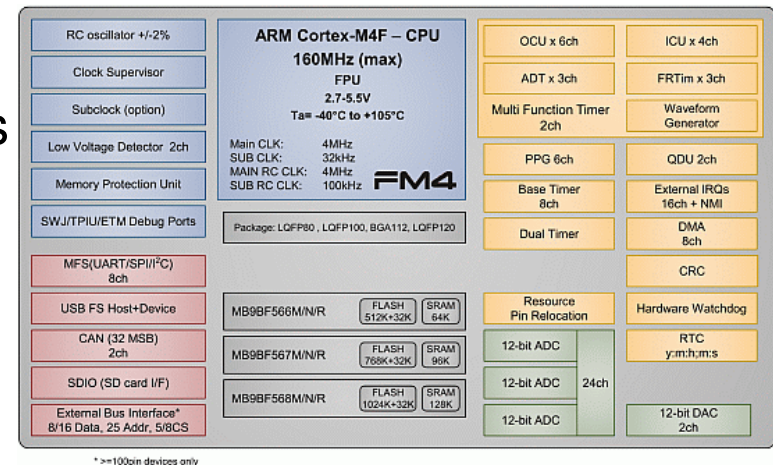

Features of the board

- The SK-FM4-U120-9B560(-MEM) is available in two versions:

Feature	SK-FM4-U120-9B560	SK-FM4-U120-9B560-MEM
External Power Supply	USB, DAP, JTAG or from SK-FM4-U-PERIPHERAL	
On-board Voltage	3.3V or 5V	3.3V
User-LEDs, Reset-LED	3x User-LEDs (R,G,B) + Reset	
Buttons	3x buttons: Reset + External Interrupt + NMI	
Potentiometer	AN18 (0V .. On-board voltage 3.3V/5V)	
Debug interface	On-board CMSIS-DAP incl. Status LEDs (connected, running) (optional 20 pin JTAG-IF to be used with external JTAG adapter)	
Virtual COM port (USB-2-UART bridge)	Yes	
USB interface	USB Function (Mini-USB Type B)	
SD-Card interface	Yes	No
External Memory	No	NAND-Flash: 32MByte SDRAM: 16MByte

Contents SK-FM4-U120-9B560

- The SK-FM4-U120-9B560(-MEM) contents
 - The SK-FM4-U120-9B560 or SK-FM4-U120-9B560-MEM evaluation board
 - One USB mini cable
 - 1-page flyer

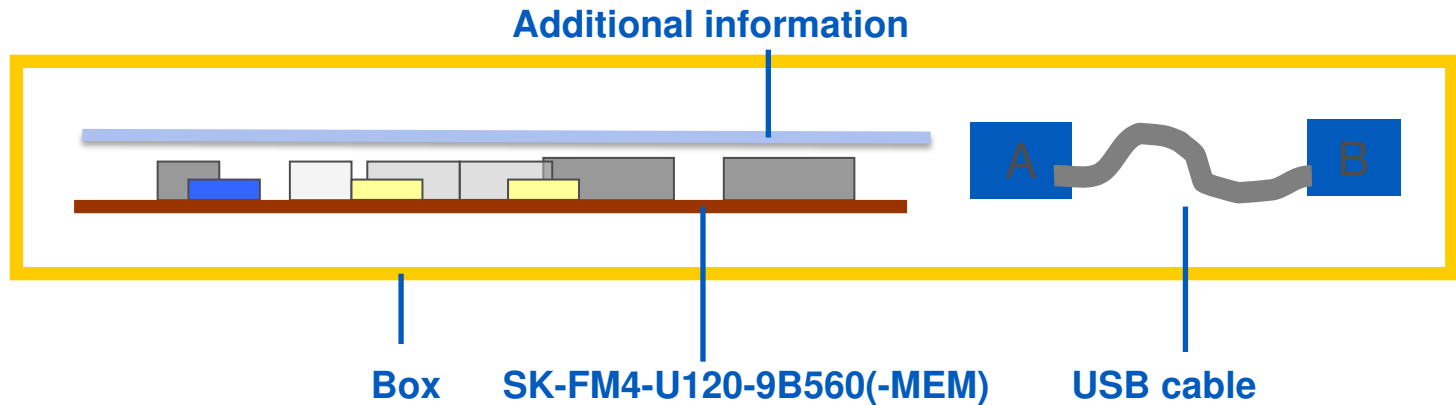

Please check jumper setting

SK-FM4-U120-9B560 supports 5V and 3.3V operation
SK-FM4-U120-9B560-MEM supports only 3.3V operation

Note:

Please set **J9 (USB)** instead of **J7 (CMSIS-DAP)**
Please set **J19 and J20:1-2 (SINO/SOTO)**

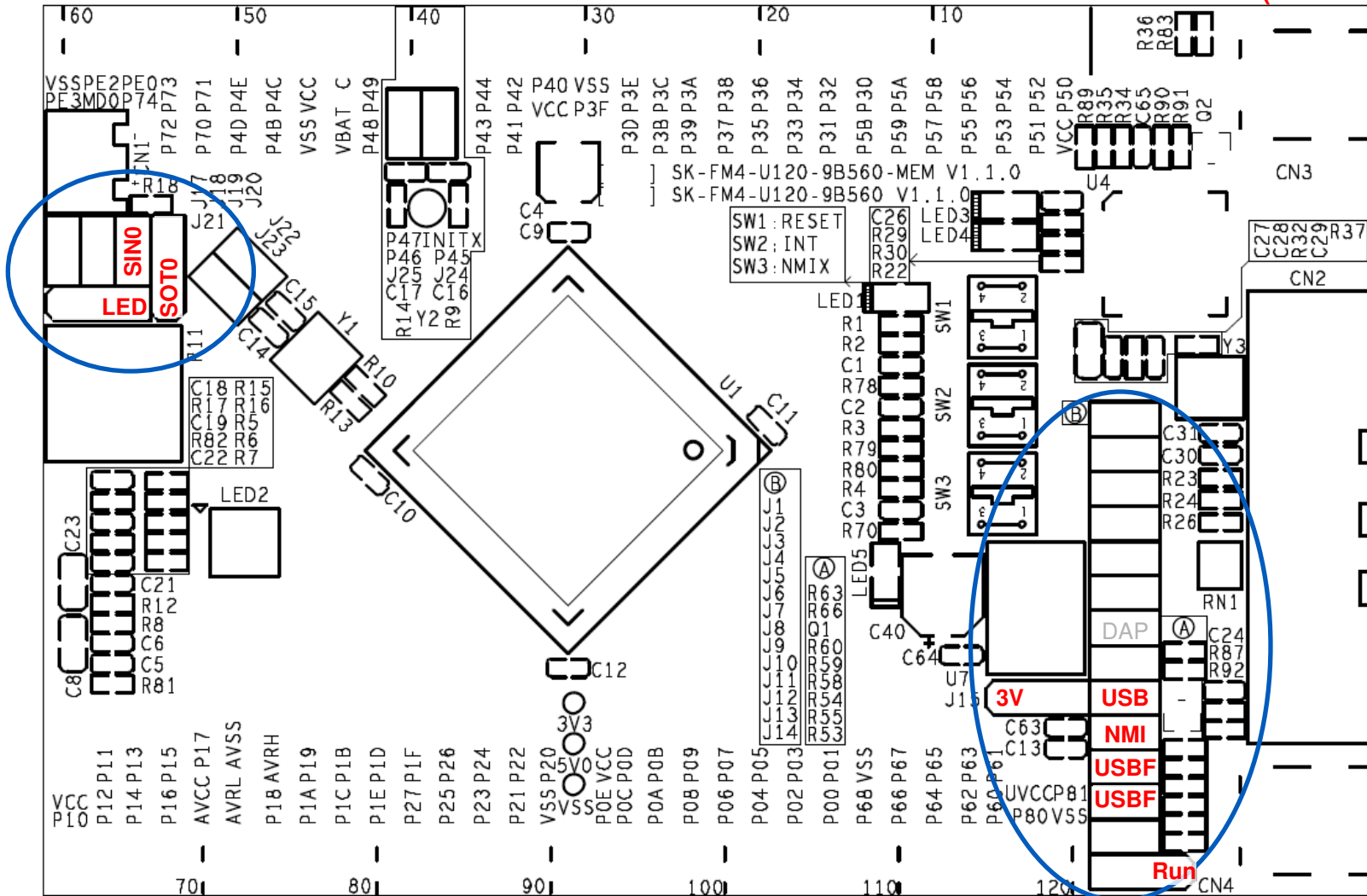

Test it by terminal using USB

- The microcontroller on the SK-FM4-U120-9B560(-MEM) is already preprogrammed with a test application (<drive:>\sw-examples\testsoftware)
 - Install the USB driver first <drive:>\drivers\driverinstaller.exe
 - Connect the starter kit to CN4 (USB) with your PC
 - ✓ Ensure jumper J9 (USB) is set for correct power supply
 - ✓ Ensure jumper J19 and J20:1-2 are set correctly for use of SIN0/SOT0
 - Press the ,Reset'- Button
 - Check the availability for virtual COM port
 - ✓ e.g. Windows Device Manager
 - Open a serial terminal tool
 - ✓ e.g. Cypress Serial Port Viewer
 - <drive:>\tools\serialportviewer\setup.exe
 - ✓ Settings 115200 baud, 8N1
 - Press <space> to show welcome menu
 - Please select any function to test the on-board features

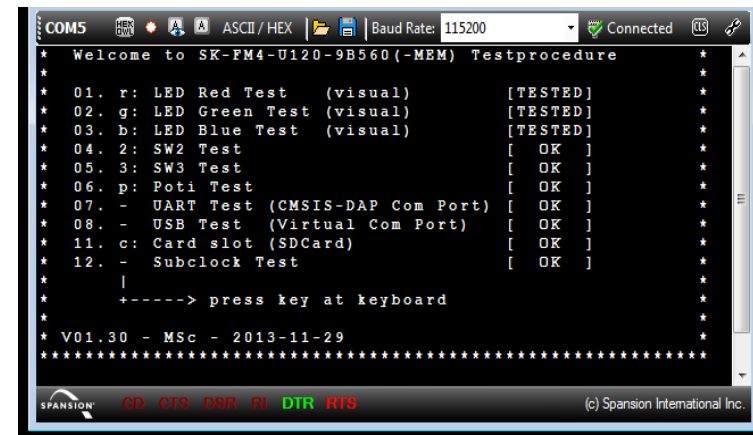
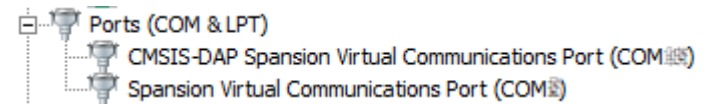

```
COM5  Baud Rate: 115200  Connected
* Welcome to SK-FM4-U120-9B560(-MEM) Testprocedure *
* 01. r: LED Red Test (visual) [TESTED] *
* 02. g: LED Green Test (visual) [TESTED] *
* 03. b: LED Blue Test (visual) [TESTED] *
* 04. 2: SW2 Test [ OK ] *
* 05. 3: SW3 Test [ OK ] *
* 06. p: Pot1 Test [ OK ] *
* 07. - UART Test (CMSIS-DAP Com Port) [ OK ] *
* 08. - USB Test (Virtual Com Port) [ OK ] *
* 11. c: Card slot (SDCard) [ OK ] *
* 12. - Subclock Test [ OK ] *
* | *
* +-----> press key at keyboard *
* *
* V01.30 - MSc - 2013-11-29 *
*****
SPANSTON  CD  CTS  DSR  RI  DTR  RTS  (c) Spansion International Inc.
```

Test it by a GUI

- The microcontroller on the SK-FM4-U120-9B560(-MEM) is already preprogrammed with a test application (<drive:>\sw-examples\testsoftware)
 - Install the USB driver first <drive:>\drivers\driverinstaller.exe
 - Connect the starter kit to CN4 (USB) with your PC
 - Open the PC software <drive:>\sw-examples\testsoftware\SK-FM4-U120-9B560_demo.exe
 - The picture of the board will be shown with current status of on-board features
 - LED allows control of the RGB-LED
 - ✓ Just click to the checkboxes
 - Status of user-buttons SW2 and SW3 are shown interactively
 - ADC represents the potentiometer R11

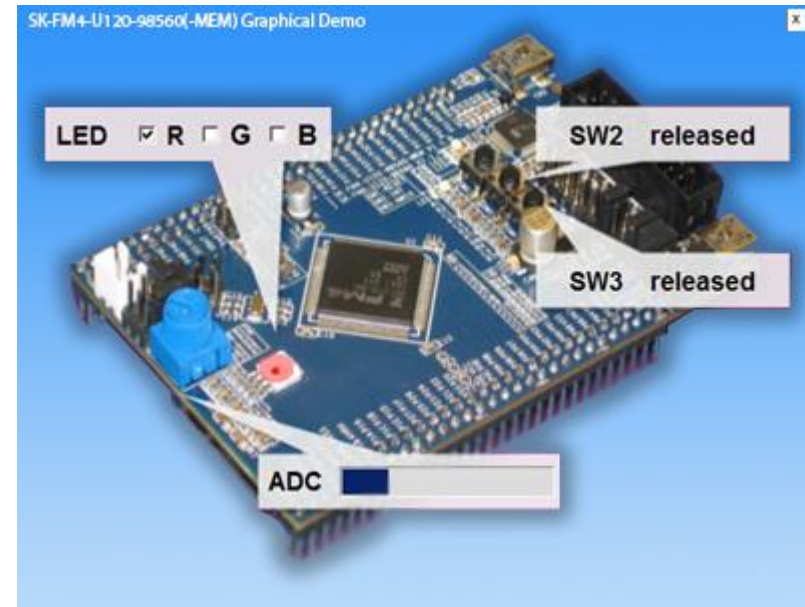

- You finished successfully the first test

Congratulation!

- Next section covers:
 - The on-board features
 - How to program the Flash
 - ✓ Serial ROM Boot loader
 - USB Direct
 - UART0
 - ✓ On-board CMSIS-DAP
 - ✓ JTAG with optional emulator
 - How to start with IAR-Embedded-Workbench and KEIL μ Vision



Hardware

The Hardware (Top Side) – Jumper Overview

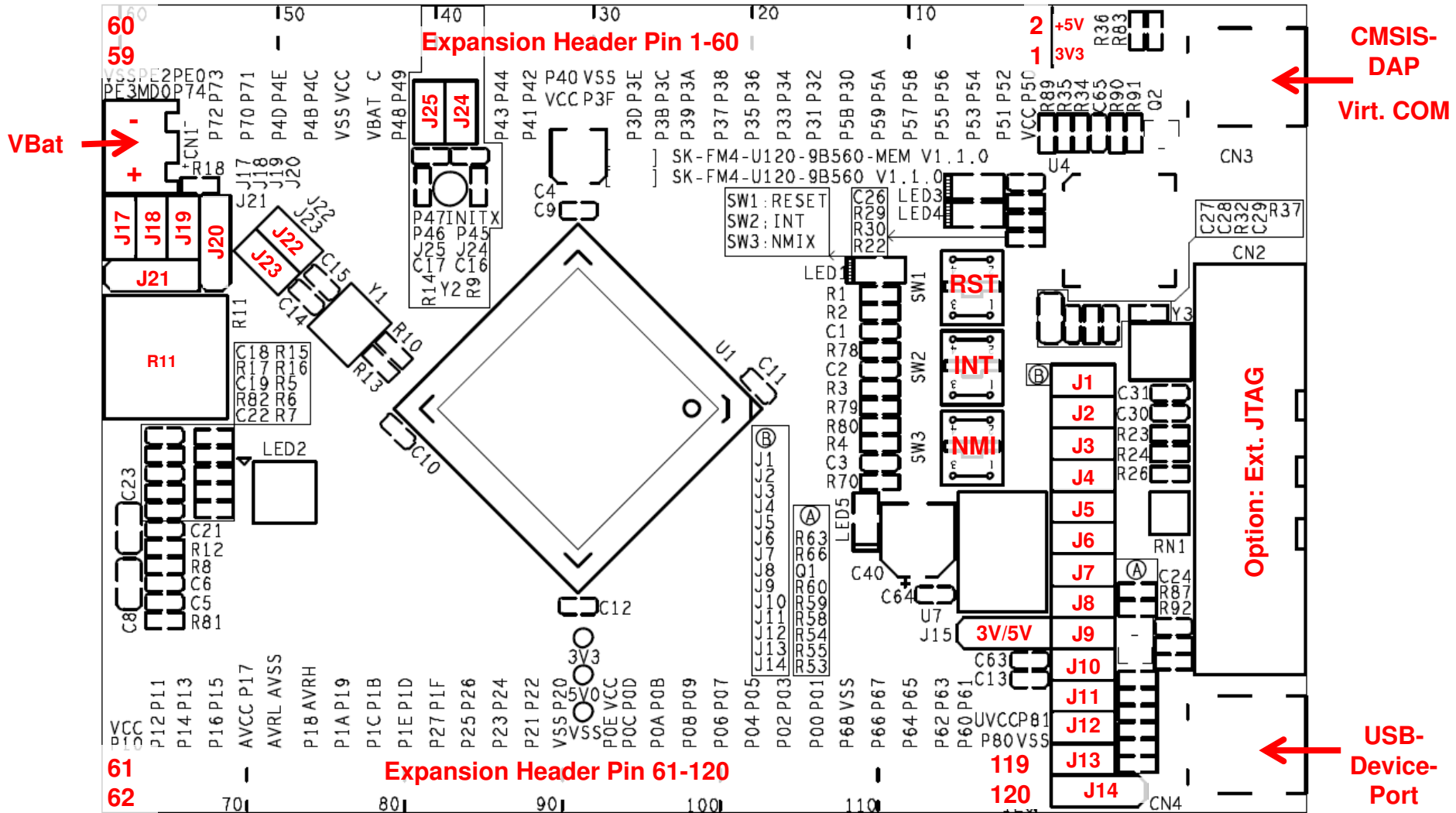

The Hardware (Top Side) – Jumper Function Overview

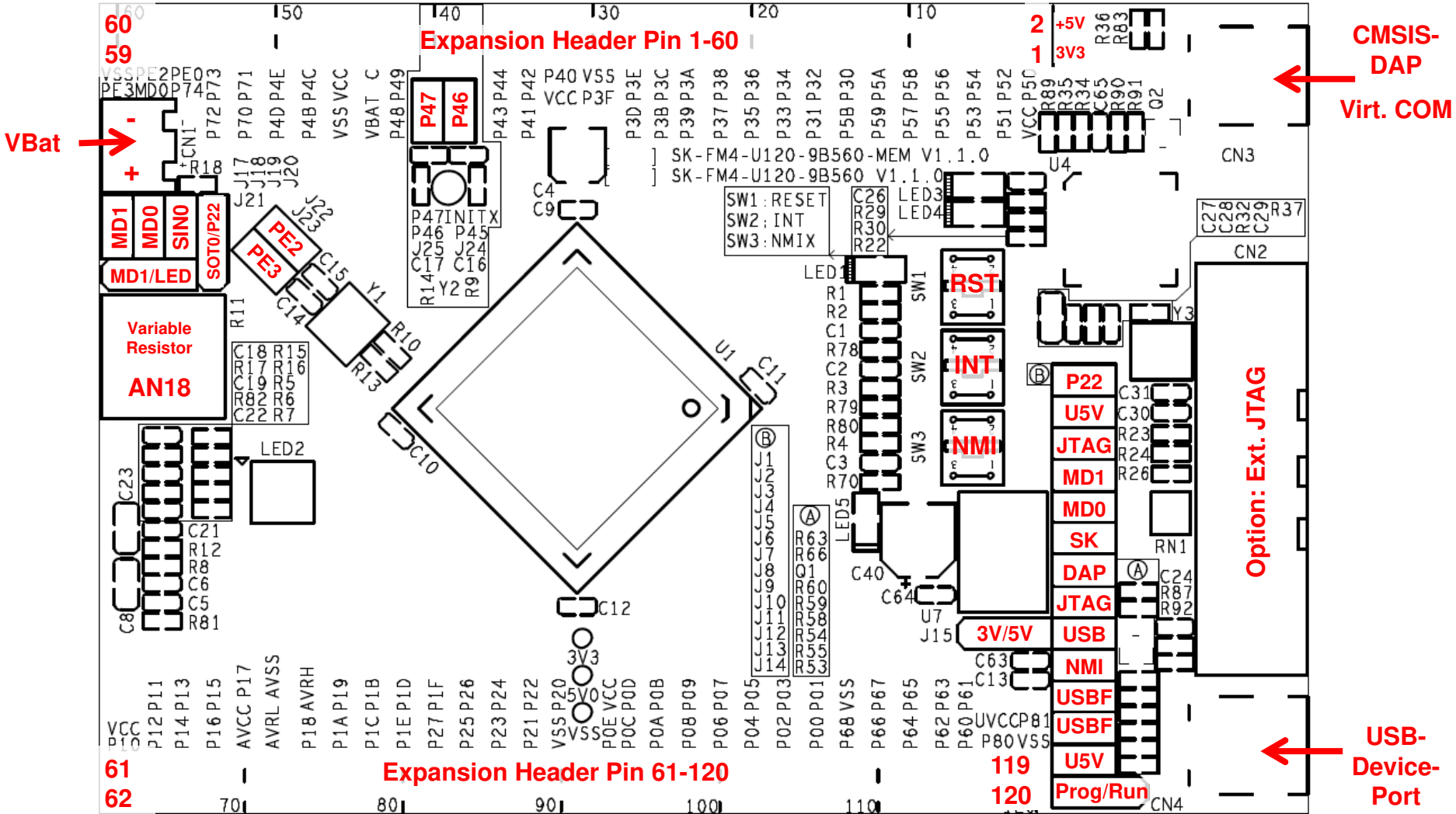

The Hardware (Bottom Side)

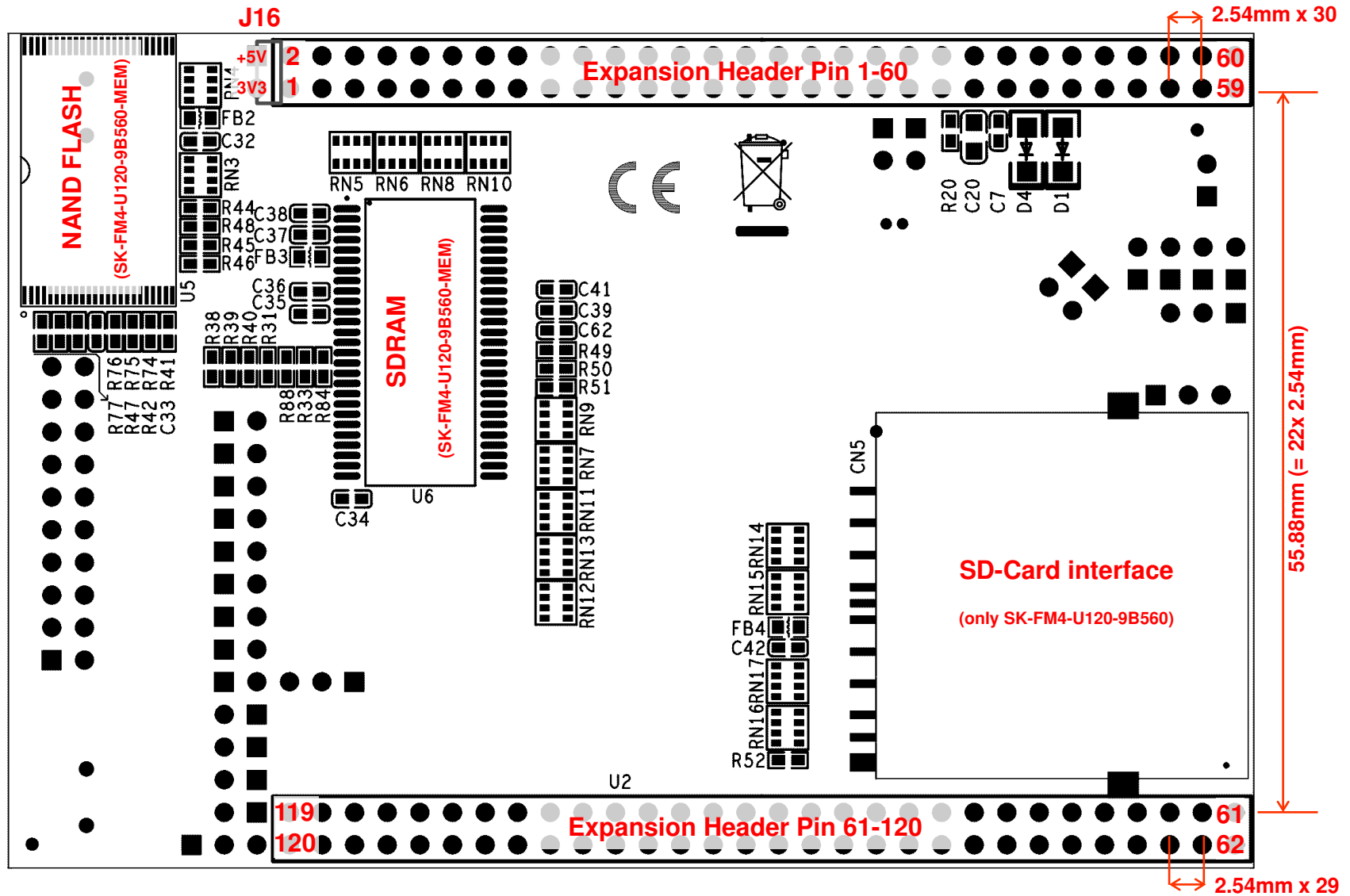

The Hardware – Pin Overview 1 - 20



Pin	Microcontroller-Function	SK-FM4-U120-9B560	SK-FM4-U120-9B560-MEM
1	VCC	VCC_MCU 3V3 or 5V0	VCC_MCU 3V3 or 5V0
2	P50/CTS4_0/AIN0_2/RTO10_0/INT00_0/MADATA00_0		SDRAM, NAND FLASH
3	P51/RTS4_0/BIN0_2/RTO11_0/INT01_0/MADATA01_0		SDRAM, NAND FLASH
4	P52/SCK4_0/ZIN0_2/RTO12_0/MADATA02_0		SDRAM, NAND FLASH
5	P53/TIOA1_2/SOT4_0/RTO13_0/MADATA03_0		SDRAM, NAND FLASH
6	P54/TIOB1_2/SIN4_0/RTO14_0/INT02_0/MADATA04_0		SDRAM, NAND FLASH
7	P55/ADTG_1/SIN6_0/RTO15_0/INT07_2/MADATA05_0		SDRAM, NAND FLASH
8	P56/SOT6_0/DTTI1X_0/INT08_2/MADATA06_0		SDRAM, NAND FLASH
9	P57/SCK6_0/MADATA07_0		SDRAM, NAND FLASH
10	P58/SIN4_2/AIN1_0/INT04_2/MADATA08_0		SDRAM
11	P59/RX1_1/SOT4_2/BIN1_0/INT07_1/MADATA09_0		SDRAM
12	P5A/TX1_1/SCK4_2/ZIN1_0/MADATA10_0		SDRAM
13	P5B/CTS4_2/MADATA11_0		SDRAM
14	P30/TIOB0_1/RTS4_2/INT15_2/WKUP1/MADATA12_0		SDRAM
15	P31/TIOB1_1/SIN3_1/INT09_2/MADATA13_0		SDRAM
16	P32/TIOB2_1/SOT3_1/INT10_1/MADATA14_0		SDRAM
17	P33/ADTG_6/TIOB3_1/SCK3_1/INT04_0/MADATA15_0		SDRAM
18	P34/TX0_1/TIOB4_1/FRCK0_0/MNALE_0		NAND FLASH
19	P35/RX0_1/TIOB5_1/IC03_0/INT08_1/MNCLE_0		NAND FLASH
20	P36/SIN5_2/IC02_0/INT09_1/MNWEX_0		NAND FLASH

The Hardware – Pin Overview 21 - 40



Pin	Microcontroller-Function	SK-FM4-U120-9B560	SK-FM4-U120-9B560-MEM
21	P37/SOT5_2/IC01_0/INT05_2/MNREX_0		NAND FLASH
22	P38/SCK5_2/IC00_0/INT06_2	LED_G	LED_G
23	P39/ADTG_2/DTTI0X_0/RTCCO_2/SUBOUT_2/MSDCLK_0		SDRAM
24	P3A/TIOA0_1/AIN0_0/RTO00_0/MSDCKE_0		SDRAM
25	P3B/TIOA1_1/BIN0_0/RTO01_0/MRASX_0		SDRAM
26	P3C/TIOA2_1/ZIN0_0/RTO02_0/MCASX_0		SDRAM
27	P3D/TIOA3_1/RTO03_0/MAD00_0		SDRAM
28	P3E/TIOA4_1/RTO04_0/MAD01_0		SDRAM
29	P3F/TIOA5_1/RTO05_0/MAD02_0		SDRAM
30	VSS	GND	GND
31	VCC	VCC_MCU 3V3 or 5V0	VCC_MCU 3V3 or 5V0
32	P40/TIOA0_0/RTO10_1/INT12_1		
33	P41/TIOA1_0/RTO11_1/INT13_1		
34	P42/TIOA2_0/RTO12_1/MSDWEX_0		SDRAM
35	P43/ADTG_7/TIOA3_0/RTO13_1/MCSX8_0		SDRAM
36	P44/TIOA4_0/RTO14_1/DA0		
37	P45/TIOB0_0/RTO15_1/DA1		
38	INITX	Button Reset / JTAG	Button Reset / JTAG
39	P46/X0A	Sub-Crystal 32.768 kHz	Sub-Crystal 32.768 kHz
40	P47/X1A	Sub-Crystal 32.768 kHz	Sub-Crystal 32.768 kHz

The Hardware – Pin Overview 41 - 60



Pin	Microcontroller-Function	SK-FM4-U120-9B560	SK-FM4-U120-9B560-MEM
41	P48/VREGCTL		
42	P49/VWAKEUP	Pull-Down resistor	Pull-Down resistor
43	VBAT	Battery (CN1)	Battery (CN1)
44	C	Capacitor 4u7	Capacitor 4u7
45	VSS	GND	GND
46	VCC	VCC_MCU 3V3 or 5V0	VCC_MCU 3V3 or 5V0
47	P4B/TIOB1_0/SCS7_1/MAD03_0		SDRAM
48	P4C/TIOB2_0/SCK7_1/AIN1_2/MAD04_0		SDRAM
49	P4D/TIOB3_0/SOT7_1/BIN1_2/INT13_2/MAD05_0		SDRAM
50	P4E/TIOB4_0/SIN7_1/ZIN1_2/FRCK1_1/INT11_1/WKUP2/MAD06_0		SDRAM
51	P70/TX0_0/TIOA4_2/AIN0_1/IC13_1		
52	P71/RX0_0/TIOB4_2/BIN0_1/IC12_1/INT15_1		
53	P72/TIOA6_0/SIN2_0/ZIN0_1/IC11_1/INT14_2		
54	P73/TIOB6_0/SOT2_0/IC10_1/INT03_2	USB	USB
55	P74/SCK2_0/DTT11X_1		
56	PE0/MD1	LED_B / MD1	LED_B / MD1
57	MD0	MD0	MD0
58	PE2/X0	Main-Crystal 4 MHz	Main-Crystal 4 MHz
59	PE3/X1	Main-Crystal 4 MHz	Main-Crystal 4 MHz
60	VSS	GND	GND

The Hardware – Pin Overview 61 - 80



Pin	Microcontroller-Function	SK-FM4-U120-9B560	SK-FM4-U120-9B560-MEM
61	VCC	VCC_MCU 3V3 or 5V0	VCC_MCU 3V3 or 5V0
62	P10/AN00/RX1_2/SIN1_1/FRCK0_2/INT02_1/MAD07_0		SDRAM
63	P11/AN01/TX1_2/SOT1_1/IC00_2/MAD08_0		SDRAM
64	P12/AN02/SCK1_1/IC01_2/RTCCO_1/SUBOUT_1/MAD09_0		SDRAM
65	P13/AN03/SIN0_1/IC02_2/INT03_1/MAD10_0		SDRAM
66	P14/AN04/SOT0_1/IC03_2/MAD11_0		SDRAM
67	P15/AN05/SCK0_1/MAD12_0		
68	P16/AN06/SIN2_2/INT14_1/MAD13_0		
69	P17/AN07/SOT2_2/WKUP3/MAD14_0		SDRAM
70	AVCC	VCC_MCU	VCC_MCU
71	AVSS	GND	GND
72	AVRL	GND	GND
73	AVRH	VCC_MCU	VCC_MCU
74	P18/AN08/SCK2_2/MAD15_0		SDRAM
75	P19/AN09/SIN4_1/IC00_1/INT05_1/MAD16_0		
76	P1A/AN10/SOT4_1/IC01_1/MAD17_0		
77	P1B/AN11/SCK4_1/IC02_1/MAD18_0		
78	P1C/AN12/CTS4_1/IC03_1/MAD19_0		
79	P1D/AN13/RTS4_1/DTTIOX_1/MAD20_0		
80	P1E/AN14/ADTG_5/FRCK0_1/MAD21_0		

The Hardware – Pin Overview 81 - 100



Pin	Microcontroller-Function	SK-FM4-U120-9B560	SK-FM4-U120-9B560-MEM
81	P1F/ADTG_4/TIOB6_2/RTO05_1		
82	P27/TIOA6_2/RTO04_1/INT02_2	LED_R	LED_R
83	P26/TIOB5_0/SCK2_1/RTO03_1		
84	P25/TX1_0/TIOA5_0/SOT2_1/RTO02_1		
85	P24/RX1_0/SIN2_1/RTO01_1/INT01_2		
86	P23/AN15/TIOA7_1/SCK0_0/RTO00_1/MAD22_0		
87	P22/CROUT_0/AN16/TIOB7_1/SOT0_0/ZIN1_1	JTAG	JTAG
88	P21/AN17/SIN0_0/BIN1_1/INT06_1/MAD23_0	JTAG	JTAG
89	P20/AN18/AIN1_1/INT05_0/MAD24_0	Potentiometer R11	Potentiometer R11
90	VSS	GND	GND
91	VCC	VCC_MCU 3V3 or 5V0	VCC_MCU 3V3 or 5V0
92	P0E/TIOB5_2/SCS6_1/IC13_0/S_CLK_0/MDQM1_0	SD-Card	SDRAM
93	P0D/TIOA5_2/SCK6_1/IC12_0/S_CMD_0/MDQM0_0	SD-Card	SDRAM
94	P0C/TIOA6_1/SOT6_1/IC11_0/S_DATA1_0/MALE_0	SD-Card	
95	P0B/TIOB6_1/SIN6_1/IC10_0/INT00_1/S_DATA0_0/MCSX0_0	SD-Card	NAND FLASH
96	P0A/SIN1_0/FRCK1_0/INT12_2/S_DATA3_0/MCSX1_0	SD-Card	
97	P09/AN19/TRACED0/TIOA3_2/SOT1_0/S_DATA2_0/MCSX5_0	SD-Card	
98	P08/AN20/TRACED1/TIOB3_2/SCK1_0/MCSX4_0		
99	P07/AN21/TRACED2/TIOA0_2/SCK7_0/MCLKOUT_0		
100	P06/AN22/TRACED3/TIOB0_2/SOT7_0/MCSX3_0		

The Hardware – Pin Overview 101 - 120



Pin	Microcontroller-Function	SK-FM4-U120-9B560	SK-FM4-U120-9B560-MEM
101	P05/AN23/ADTG_0/TRACECLK/SIN7_0/INT01_1/MCSX2_0		
102	P04/TDO/SWO	JTAG	JTAG
103	P03/TMS/SWDIO	JTAG	JTAG
104	P02/TDI/MCSX6_0	JTAG	JTAG
105	P01/TCK/SWCLK	JTAG	JTAG
106	P00/TRSTX/MCSX7_0	JTAG	JTAG
107	VSS	GND	GND
108	P68/TIOB7_2/SCK3_0/INT00_2	Button INT	Button INT
109	P67/TIOA7_2/SOT3_0		
110	P66/ADTG_8/SIN3_0/INT11_2		
111	P65/TIOB7_0/SCK5_1		
112	P64/TIOA7_0/SOT5_1/INT10_2		
113	P63/CROUT_1/RX0_2/SIN5_1/INT03_0/S_CD_0/MWEX_0	SD-Card	
114	P62/ADTG_3/TX0_2/SIN5_0/INT04_1/S_WP_0/MOEX_0	SD-Card	
115	P61/UHCONX0/TIOB2_2/SOT5_0/RTCCO_0/SUBOUT_0	USB	USB
116	P60/TIOA2_2/SCK5_0/NMIX/WKUP0/MRDY_0	Button NMIX	Button NMIX
117	USBVCC	3V3	3V3
118	P80/UDM0	USB	USB
119	P81/UDP0	USB	USB
120	VSS	GND	GND

Jumper table

Jumper	Function	SK-FM4-U120-9B560(-MEM) (Default setting marked bold)
J1 (2 pin)	CMSIS-DAP Crystal (P22) (Do not change!)	Open: 4MHz Closed: 48MHz
J2 (2 pin)	VBUS detection of CMSIS-DAP	Open: 3V3 Closed: 5V (only for SK-FM4-U120-9B560)
J3 (2 pin)	CMSIS-DAP reset	Open: CMSIS-DAP normal operation Closed: CMSIS-DAP reset assert
J4 (2 pin)	Operation of MD1 (CMSIS-DAP)	Open: Run-Mode Closed: Test-Mode
J5 (2 pin)	Operation of MD0 (CMSIS-DAP)	Open: Run-Mode (CMSIS-DAP) Closed: Firmware update of CMSIS-DAP
J6-J9	Power Supply Source Please select just one power source!	J9: USB Host powered (CN4) J8: JTAG powered (CN2) J7: CMSIS-DAP powered (CN3) J6: Powered by SK-FM4-U-PERIPHERAL (J16)
J10 (2 pin)	SW3 NMI Jumper J10 needs to be opened for programming	Open: Button SW3 disconnected / Programming mode Closed: Button SW3 (NMI) is connected
J11 (2 pin)	USB D+	Open: USB is disconnected Closed: USB is connected
J12 (2 pin)	USB D-	Open: USB is disconnected Closed: USB is connected
J13 (2 pin)	VBUS detection	Open: 3V3 Closed: 5V (only for SK-FM4-U120-9B560)

Jumper table (continued)

Jumper	Function	SK-FM4-U120-9B560(-MEM) (Default setting marked bold)
J14 (3 pin)	USB VBUS detection See also J10	1-2: VBUS is connected to INT03_2 (Run-Mode) 2-3: VBUS is connected to NMIX (Programming Mode)
J15 (3 pin)	MCU voltage selection SK-FM4-U120-9B560-MEM can be used with 3V3 only	1-2: MCU is powered from 3V3 2-3: MCU is powered from 5V (not SK-FM4-U120-9B560-MEM)
J17 (2 pin)	Operation of MD1 (Do not change!)	Open: Run-Mode and Programming-Mode Closed: Test-Mode
J18 (2 pin)	Operation of MD0	Open: Run-Mode Closed: Programming-Mode
J19 (2 pin)	CMSIS-DAP Virtual COM port (SIN0_0)	Open: SIN0 is disconnected from CMSIS-DAP Closed: CMSIS-DAP's virtual COM port is connected
J20 (3 pin)	CMSIS-DAP Virtual COM port (SOT0_0)	2-3: SOT0/P22 is used for USB programming 1-2: CMSIS-DAP's virtual COM port is connected
J21 (3 pin)	MD1/PE0 See also J17	1-2: MD1 (Programming-Mode) 2-3: PE0 (LED Blue)
J22 (2 pin)	X0/PE2 Do not close J22 if crystal Y1 is assembled.	Open: PE2 is disconnected Closed: PE2 is connected to pin header U2
J23 (2 pin)	X1/PE3 Do not close J23 if crystal Y1 is assembled.	Open: PE3 is disconnected Closed: PE3 is connected to pin header U2
J24 (2 pin)	X0A/P46 Do not close J24 if crystal Y2 is assembled.	Open: P46 is disconnected Closed: PE2 is connected to pin header U2
J25 (2 pin)	X1A/P47 Do not close J25 if crystal Y2 is assembled.	Open: P47 is disconnected Closed: PE2 is connected to pin header U2

Jumper – Default (Run mode, CMSIS-DAP)

SK-FM4-U120-9B560 supports 5V and 3.3V operation

SK-FM4-U120-9B560-MEM supports only 3.3V operation

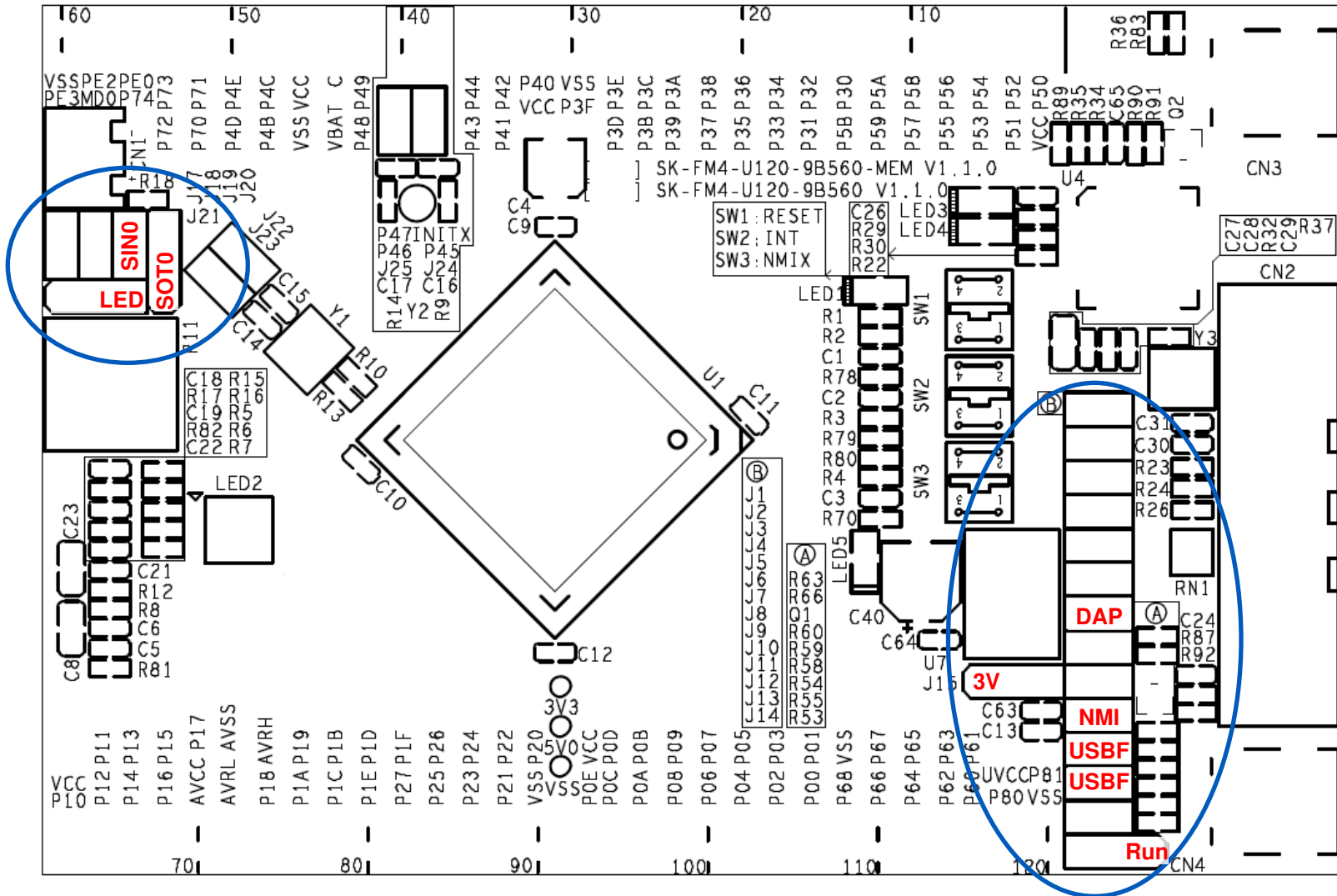

Jumper – Programming Mode (USB Direct mode)

