



Chipsmall Limited consists of a professional team with an average of over 10 year of expertise in the distribution of electronic components. Based in Hongkong, we have already established firm and mutual-benefit business relationships with customers from,Europe,America and south Asia,supplying obsolete and hard-to-find components to meet their specific needs.

With the principle of “Quality Parts,Customers Priority,Honest Operation,and Considerate Service”,our business mainly focus on the distribution of electronic components. Line cards we deal with include Microchip,ALPS,ROHM,Xilinx,Pulse,ON,Everlight and Freescale. Main products comprise IC,Modules,Potentiometer,IC Socket,Relay,Connector.Our parts cover such applications as commercial,industrial, and automotives areas.

We are looking forward to setting up business relationship with you and hope to provide you with the best service and solution. Let us make a better world for our industry!



## Contact us

Tel: +86-755-8981 8866 Fax: +86-755-8427 6832

Email & Skype: info@chipsmall.com Web: www.chipsmall.com

Address: A1208, Overseas Decoration Building, #122 Zhenhua RD., Futian, Shenzhen, China



**ASSEMBLY PROCEDURE:**

- STEP 1: PULL MOUNT TO PANEL - GRIP BREAKS-AWAY AFTER FIXING
- STEP 2: LOCATE AND ASSEMBLE FAN HOUSING

REV.	MODIFICATION.	DATE	DRN
01	Production Release	24/04/07	TC
02	ECN 2007-110	04/07/07	TC
03	ECN 2007-189	29/10/07	SF

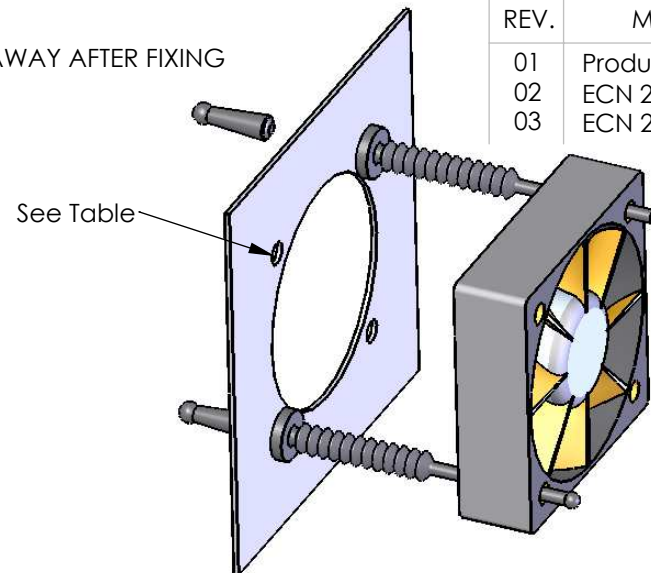

PART No	PANEL HOLE DIAMETER	PANEL THICKNESS	FAN HOLE DIAMETER	FAN CASE THICKNESS
FMB-1	4.5 - 5.0mm [0.18 - 0.20]	0.8 - 1.6mm [0.03 - 0.06]	4.0 - 4.5mm [0.16 - 0.18]	25 - 51mm [0.98 - 2.01]
FMB-2	4.5 - 5.0mm [0.18 - 0.20]	0.8 - 1.6mm [0.03 - 0.06]	3.2 - 3.5mm [0.13 - 0.14] 4.0 - 4.5mm [0.16 - 0.18]	Up to 10mm [0.40] Max Up to 25mm [0.98]

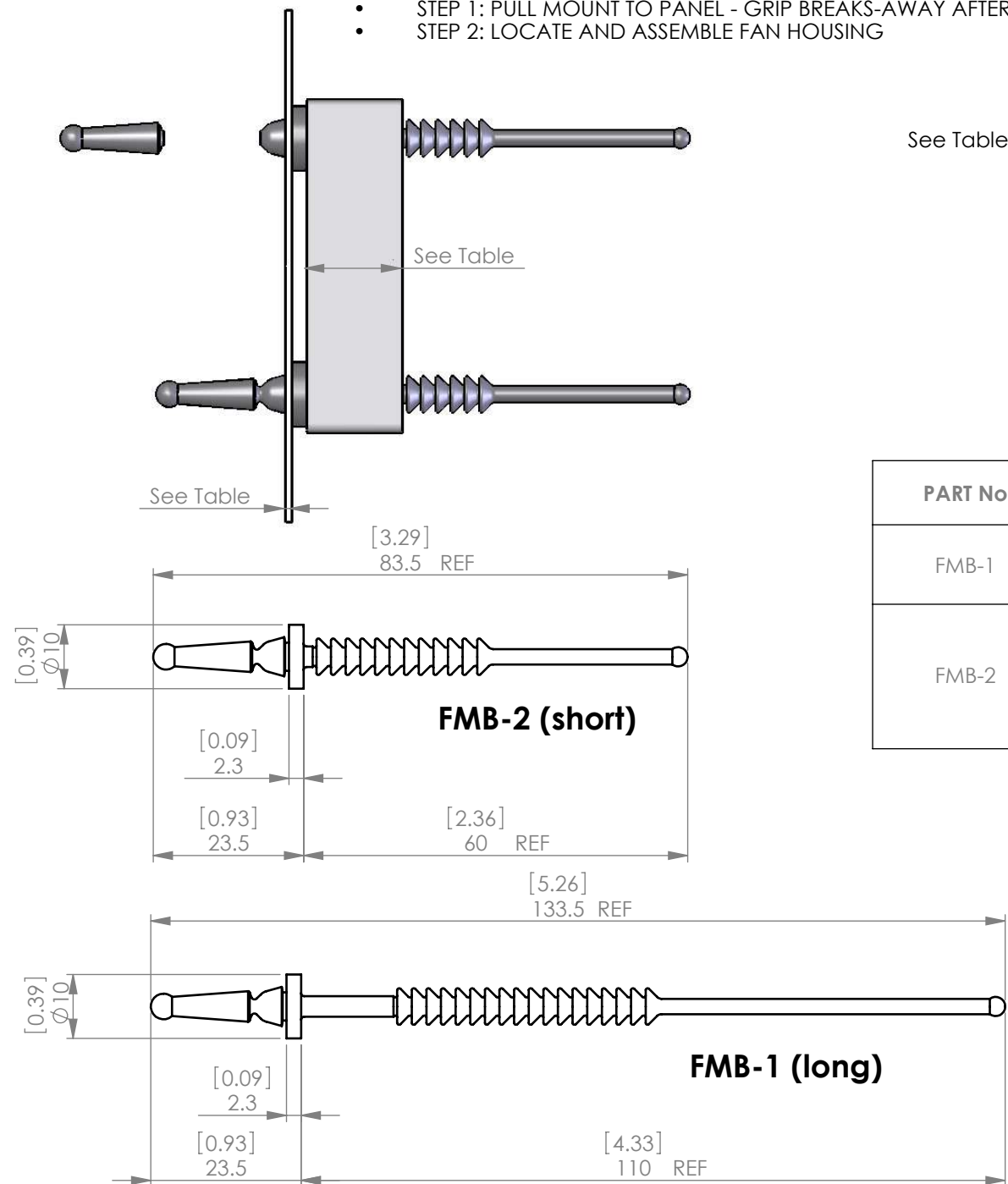

INFORMATION CONTAINED IN THIS DOCUMENT IS CONFIDENTIAL TO RICHCO INTERNATIONAL Co. Ltd. AND MAY NOT BE DISCLOSED OR REPRODUCED IN WHOLE OR PART WITHOUT THEIR WRITTEN CONSENT.



ALL DIMENSIONS IN mm & [INCH]  
 GENERAL TOLERANCES  $\pm 0.25$  [0.01]  
 UNLESS OTHERWISE STATED  
 1 DECIMAL PLACE  $\pm 0.25$  [0.01]  
 2 DECIMAL PLACES  $\pm 0.10$  [0.004]  
 ANGULAR  $\pm 1^\circ$

THIRD ANGLE



MATERIAL: SILICONE RUBBER 35 Sh A (RMS-316)		COLOUR: BLACK	
DESCRIPTION: BREAK AWAY FAN MOUNT		PART No: FMB-1 / FMB-2	
DRG No: 07-033	NPR No: 2006-312	Mass:(g) FMB-1 = 1.5g FMB-2 = 1.1g	SHEET SIZE A4
DRN TC	DATE 25/10/06	CHKD TC	DATE 28/11/06
SCALE NTS		SHEET No. 2 OF 2	