



Chipsmall Limited consists of a professional team with an average of over 10 year of expertise in the distribution of electronic components. Based in Hongkong, we have already established firm and mutual-benefit business relationships with customers from,Europe,America and south Asia,supplying obsolete and hard-to-find components to meet their specific needs.

With the principle of “Quality Parts,Customers Priority,Honest Operation,and Considerate Service”,our business mainly focus on the distribution of electronic components. Line cards we deal with include Microchip,ALPS,ROHM,Xilinx,Pulse,ON,Everlight and Freescale. Main products comprise IC,Modules,Potentiometer,IC Socket,Relay,Connector.Our parts cover such applications as commercial,industrial, and automotives areas.

We are looking forward to setting up business relationship with you and hope to provide you with the best service and solution. Let us make a better world for our industry!



Contact us

Tel: +86-755-8981 8866 Fax: +86-755-8427 6832

Email & Skype: info@chipsmall.com Web: www.chipsmall.com

Address: A1208, Overseas Decoration Building, #122 Zhenhua RD., Futian, Shenzhen, China



REV.	MODIFICATION.	DATE	DRN
01	PRODUCTION RELEASE	08/08/06	TC
02	ECN 2006-258	06/12/06	TC
03	CO2010317	11/08/08	SF
04	CO2010432	09/10/08	SF

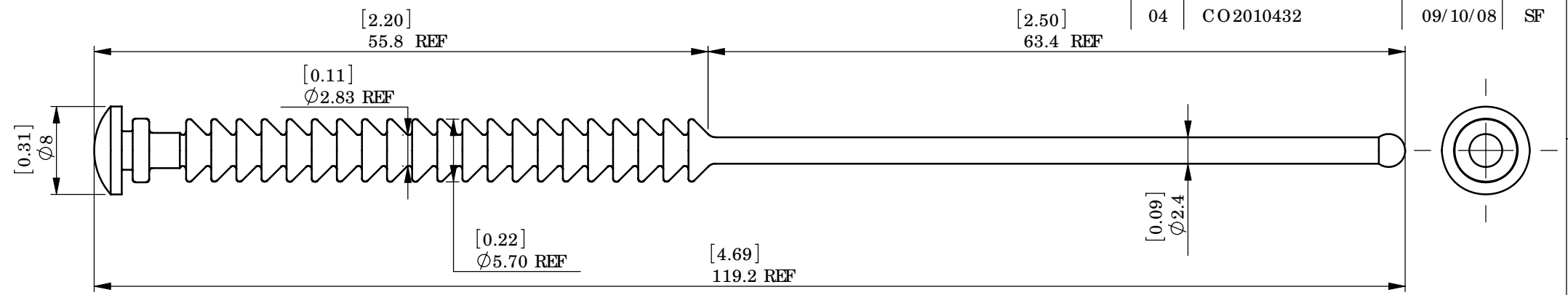

NOTES!

- Fits Industry Standard DC Fans with mounting hole size range:
- 3.2mm to 3.5mm dia up to 10mm Fan Body Thickness
 - 4.0mm to 4.5mm dia from 10mm to 51mm Fan Body Thickness
- Chassis Mounting Hole Range:
- Diameter 4.5mm to 4.8mm
 - Thickness 1mm to 1.5mm

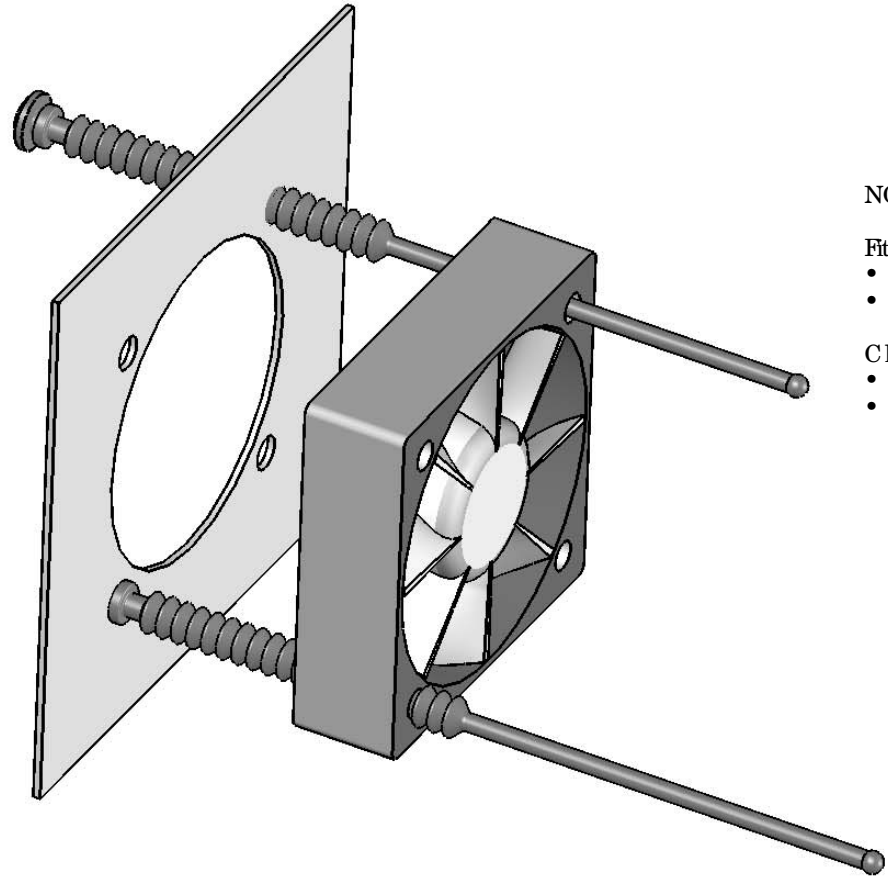

<p>INFORMATION CONTAINED IN THIS DOCUMENT IS CONFIDENTIAL TO RICHCO INTERNATIONAL Co., Ltd. AND MAY NOT BE DISCLOSED OR REPRODUCED IN WHOLE OR PART WITHOUT THEIR WRITTEN CONSENT.</p>					
		<p>ALL DIMENSIONS IN mm & [inches] GENERAL TOLERANCES ±0.25 [0.01] UNLESS OTHERWISE STATED 1 DECIMAL PLACE ±0.25 [0.01] 2 DECIMAL PLACES ±0.10 [0.004] ANGULAR ±1°</p>			<p>THIRD ANGLE</p>
<p>MATERIAL: Silicone Rubber 35 Shore 'A' (RMS-316)</p>				<p>COLOR: Black</p>	
<p>DESCRIPTION: Multi-Fan Mount</p>				<p>PART No: FMM-1</p>	
<p>DRG No: 06-076</p>		<p>NPR No: 2005-474</p>		<p>Volume: 1.16cm³</p>	<p>SHEET SIZE A4</p>
<p>DRN TC</p>	<p>DATE 27/1/06</p>	<p>CHKD TC</p>	<p>DATE 04/07/06</p>	<p>SCALE NTS</p>	<p>SHEET No. 1 OF 1</p>