



Chipsmall Limited consists of a professional team with an average of over 10 year of expertise in the distribution of electronic components. Based in Hongkong, we have already established firm and mutual-benefit business relationships with customers from,Europe,America and south Asia,supplying obsolete and hard-to-find components to meet their specific needs.

With the principle of "Quality Parts,Customers Priority,Honest Operation,and Considerate Service",our business mainly focus on the distribution of electronic components. Line cards we deal with include Microchip,ALPS,ROHM,Xilinx,Pulse,ON,Everlight and Freescale. Main products comprise IC,Modules,Potentiometer,IC Socket,Relay,Connector.Our parts cover such applications as commercial,industrial, and automotives areas.

We are looking forward to setting up business relationship with you and hope to provide you with the best service and solution. Let us make a better world for our industry!



Contact us

Tel: +86-755-8981 8866 Fax: +86-755-8427 6832

Email & Skype: info@chipsmall.com Web: www.chipsmall.com

Address: A1208, Overseas Decoration Building, #122 Zhenhua RD., Futian, Shenzhen, China





ON Semiconductor®

FMS6141

Low-Cost, Single-Channel 4th-Order Standard Definition Video Filter Driver

Features

- Single 4th-Order 8 MHz (SD) Filter
- Drives Single, AC- or DC-coupled, Video Loads ($2 V_{pp}$, 150Ω)
- Drives Dual, AC- or DC-coupled, Video Loads ($2V_{pp}$, 75Ω)
- Transparent Input Clamping
- AC- or DC-Coupled Input
- AC- or DC-Coupled Output
- DC-Coupled Output Eliminates AC-Coupling Capacitors
- Single Supply
- Robust 8 kV ESD Protection
- Lead-Free Packages: SOIC-8 or SC70-5

Applications

- Cable Set-Top Boxes
- Satellite Set-Top Boxes
- DVD Players
- HDTVs
- Personal Video Recorders (PVR)
- Video On Demand (VOD)

Description

The FMS6141 Low-Cost Video Filter is intended to replace passive LC filters and drivers with a low-cost integrated device. The 4th-order filter provides improved image quality compared to typical 2nd or 3rd-order passive solutions.

The FMS6141 may be directly driven by a DC-coupled DAC output or an AC-coupled signal. Internal diode clamps and bias circuitry may be used if an AC-coupled input is required (*see Application Information for details*).

The FMS6141's output can drive an AC- or DC-coupled single (150Ω) or dual (75Ω) load. DC-coupling the output removes the need for output coupling capacitors. The input DC level is offset approximately $+280 \text{ mV}$ at the output (*see Application Information for details*).

Related Applications Notes

- <http://www.onsemi.com/pub/Collateral/AN-6041.pdf>
- <http://www.onsemi.com/pub/Collateral/AN-6024.pdf>

Functional Block Diagram

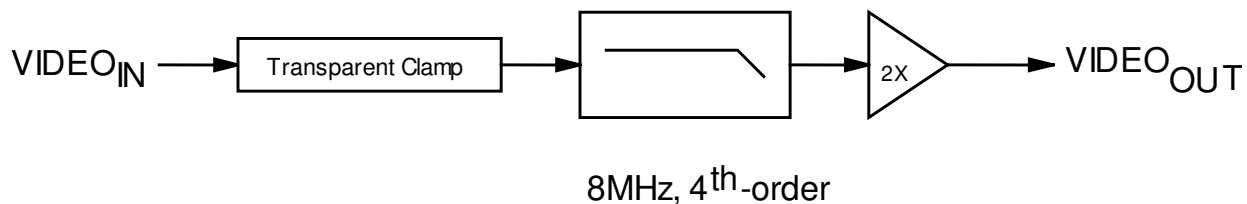

Figure 1. Block Diagram

Ordering Information

Part Number	Operating Temperature Range	Package	Packing Method
FMS6141CSX	-40°C to +85°C	8-Lead, Small Outline Integrated Circuit (SOIC)	Tape and Reel
FMS6141S5X	-40°C to +85°C	5- Lead SC70 Package	Tape and Reel

Pin Configurations

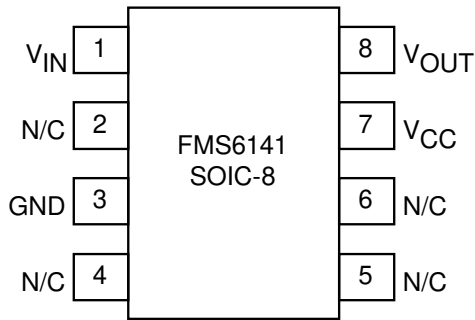

Figure 2. SOIC-8

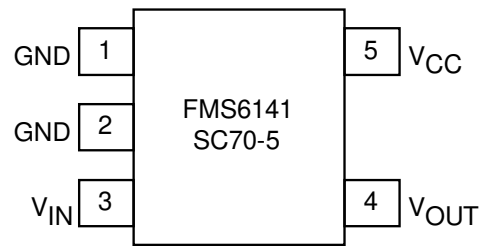

Figure 3. SC70

Pin Definitions

SOIC Pin #	SC70 Pin#	Name	Description
1	3	V_{IN}	Video Input
2		N/C	No Connect
3	1, 2	GND	Must Be Connected to Ground
4		N/C	No Connect
5		N/C	No Connect
6		N/C	No Connect
7	5	V_{CC}	+5V Supply, Do Not Float
8	4	V_{OUT}	Filtered Video Output

Absolute Maximum Ratings

Stresses exceeding the absolute maximum ratings may damage the device. The device may not function or be operable above the recommended operating conditions and stressing the parts to these levels is not recommended. In addition, extended exposure to stresses above the recommended operating conditions may affect device reliability. The absolute maximum ratings are stress ratings only.

Symbol	Parameter	Min.	Max.	Unit
V_{CC}	DC Supply Voltage	-0.3	6.0	V
V_{IO}	Analog and Digital I/O	-0.3	$V_{CC} + 0.3$	V
I_{OUT}	Output Current, Do Not Exceed		50	mA

Recommended Operating Conditions

Symbol	Parameter	Min.	Typ.	Max.	Unit
T_A	Operating Temperature Range	-40		85	°C
V_{CC}	V_{CC} Range	4.75	5.00	5.25	V

ESD Information

Symbol	Parameter	Value	Unit
ESD	Human Body Model, JESD22-A114	8.0	kV
	Charged Device Model, JESD22-C101	1.5	kV

Reliability Information

Symbol	Parameter	Min.	Typ.	Max.	Unit
T_J	Junction Temperature			+150	°C
T_{STG}	Storage Temperature Range	-65		+150	°C
T_L	Lead Temperature (Soldering, 10 s)			300	°C
Θ_{JA}	Thermal Resistance (JEDEC Standard Multi-Layer Test Boards, Still Air)	SOIC-8		115	°C/W
		SC70-5		332	°C/W

DC Specifications

$T_A = 25^\circ\text{C}$, $V_{CC} = 5.0\text{ V}$, $R_S = 37.5\ \Omega$; input is AC coupled with $0.1\ \mu\text{F}$; output is AC coupled with $220\ \mu\text{F}$ into a $150\ \Omega$ load; unless otherwise noted.

Symbol	Parameter	Conditions	Min.	Typ.	Max.	Unit
I_{CC}	Supply Current ⁽¹⁾	No Load		7	12	mA
V_{IN}	Video Input Voltage Range	Referenced to GND if DC-Coupled		1.4		V_{pp}
PSRR	Power Supply Rejection Ratio	DC		40		dB

Note:

- 100% tested at 25°C

AC Electrical Specifications

$T_A = 25^\circ\text{C}$, $V_{CC} = 5.0\text{ V}$, $R_S = 37.5\ \Omega$; input is AC coupled with $0.1\ \mu\text{F}$; output is AC coupled with $220\ \mu\text{F}$ into a $150\ \Omega$ load; unless otherwise noted.

Symbol	Parameter	Conditions	Min.	Typ.	Max.	Unit
AV	Channel Gain ⁽²⁾		5.6	6.0	6.4	dB
f_{1dB}	-1dB Bandwidth ⁽²⁾		4.0	6.5		MHz
f_C	-3dB Bandwidth			7.7		MHz
f_{SB}	Attenuation (Stopband Reject)	$f = 27\text{ MHz}$		42		dB
dG	Differential Gain			0.4		%
$d\phi$	Differential Phase			0.4		$^\circ$
THD	Output Distortion (all channels)	$V_{OUT} = 1.8 V_{pp}$, 1 MHz		0.4		%
SNR	Signal-to-Noise Ratio	NTC-7 Weighting; 100 kHz to 4.2 MHz		75		dB
t_{pd}	Propagation Delay	Delay from input to output, 4.5 MHz		55		ns

Note:

- 100% tested at 25°C

Application Information

Input Considerations

The FMS6141 Low-Cost Video Filter provides 6 dB (2X) gain from input to output. The device provides an internal diode clamp to support AC-coupled input signals. In this configuration, a 0.1 μ F ceramic capacitor is used to AC couple the input signal. If the input signal does not go below ground, the clamp is inactive; but if the input signal goes below ground, the clamp circuitry sets the bottom of the sync tip (or lowest voltage) to just below ground. The input level set by the clamp, combined with the internal DC offset, keeps the output signal within an acceptable range. This clamp feature also allows the FMS6141's input to be directly driven (DC-coupled) by a ground referenced DAC output. Figure 4 shows typical DC voltage levels for the input and output signals when driven by a DC-coupled DAC output or an AC-coupled and clamped Y, CV signal.

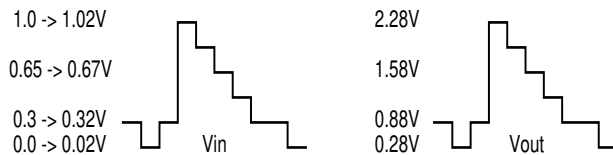

Figure 4. Typical DC Voltage Levels

Output Considerations

The FMS6141 outputs will be DC offset from the input by 150 mV therefore $V_{OUT} = 2 \cdot V_{IN} + 150 \text{ mV}$. This offset is required to obtain optimal performance from the output driver and is held at the minimum value in order to decrease the standing DC current into the load. Since the FMS6141 has a 2x (6 dB) gain, the output is typically connected via a 75 Ω series back-matching resistor followed by the 75 Ω video cable. Because of the inherent divide by two of this configuration, the blanking level at the load of the video signal is always less than 1 V. When AC-coupling the output ensure that the coupling capacitor of choice will pass the lowest frequency content in the video signal and that line time distortion (video tilt) is kept as low as possible.

The selection of the coupling capacitor is a function of the subsequent circuit input impedance and the leakage current of the input being driven. In order to obtain the highest quality output video signal the series termination resistor must be placed as close to the device output pin as possible. This greatly reduces the parasitic capacitance and inductance effect on the FMS6141 output driver. Recommended distance from device pin to place series termination resistor should be no greater than 0.1 inches.

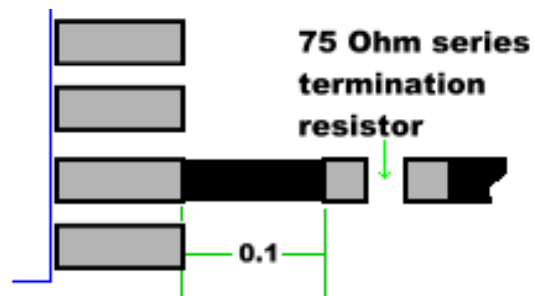

Figure 5. Distance from Device Pin to Series Termination Resistor

I/O Configurations

Figure 6 shows a typical AC-coupled input configuration for driving the filter/driver. Using this configuration, a 0.1 μF ceramic capacitor is used to AC couple the input

signal. The coupling capacitor and the input termination resistor at the input of the filter/driver should be placed close to the input pin for optimal signal integrity.

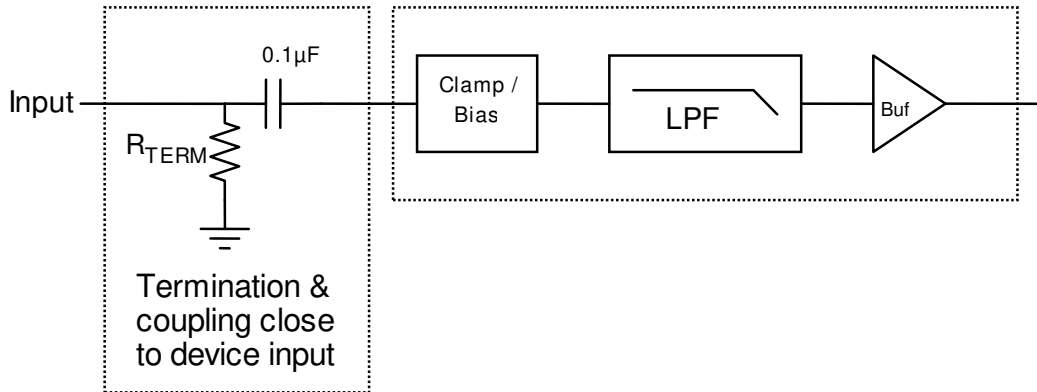

Figure 6. Typical Input Configuration

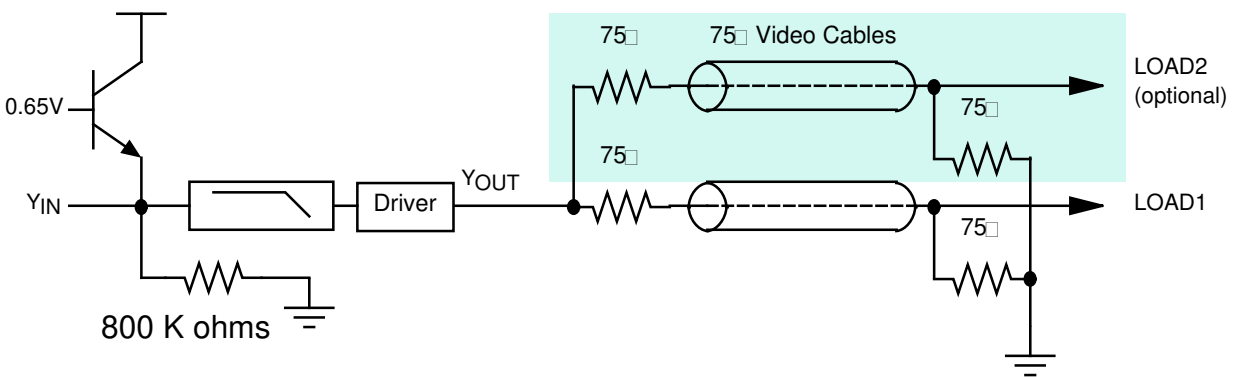

Figure 7. Conceptual Illustration — Input Clamp Circuit and Output Driver Connected to Drive Single or Dual Video Loads

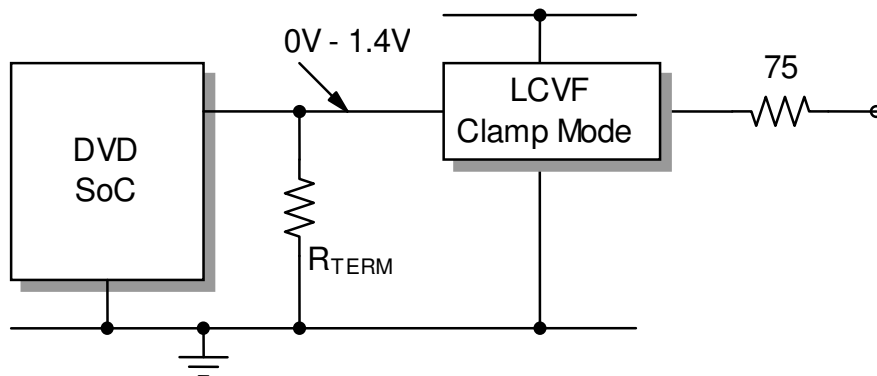

Figure 8. DC-Coupled Input and DC-Coupled Output

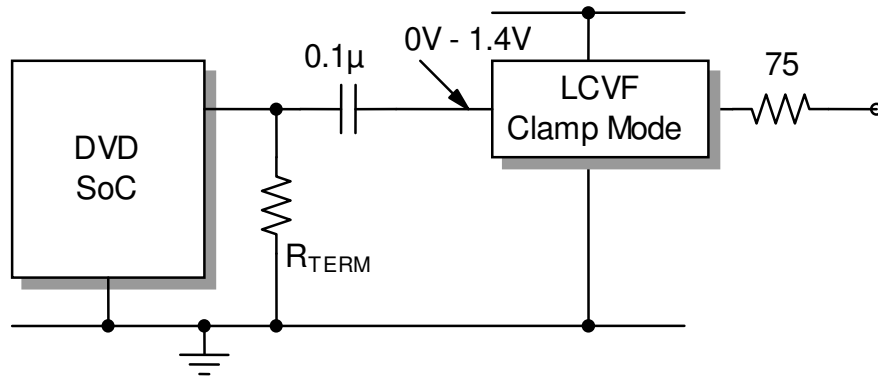

Figure 9. AC-Coupled Input and DC-Coupled Output

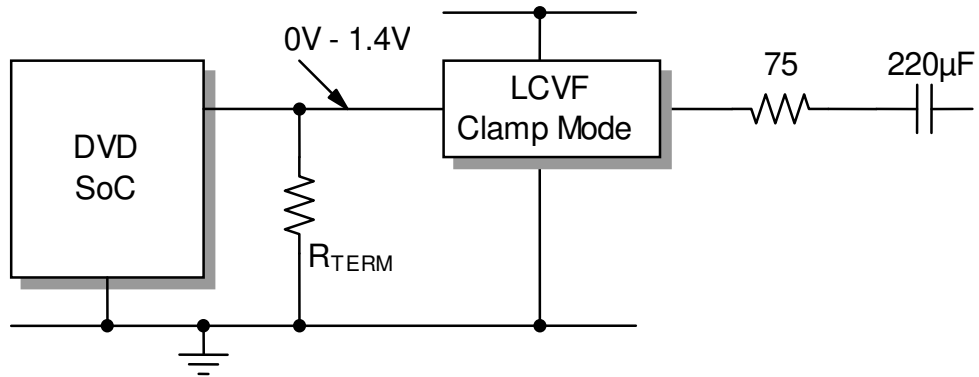

Figure 10. DC-Coupled Input and AC-Coupled Output

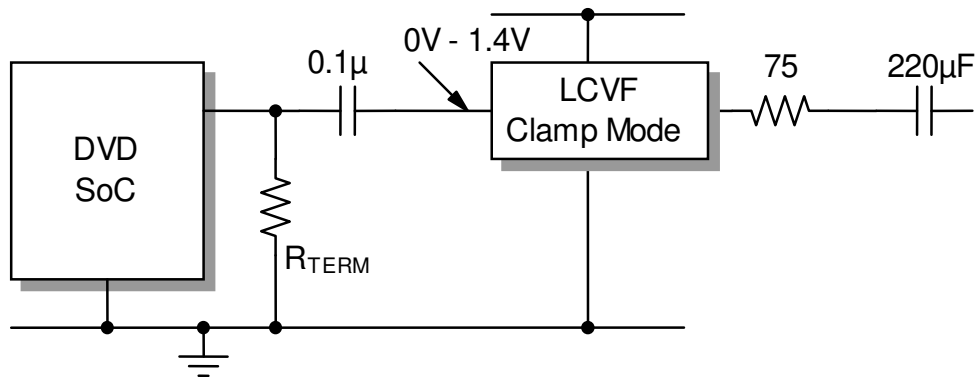

Figure 11. AC-Coupled Input and AC-Coupled Output

Layout Considerations

General layout and supply bypassing play a major role in high-frequency performance and thermal characteristics. ON Semiconductor offers a demonstration board for the FMS6141 to guide layout and aid device evaluation. The demo board is a four-layer board with full power and ground planes. Following this layout configuration provides optimum performance and thermal characteristics for the device. For the best results, follow the steps and recommended routing rules listed below.

Recommended Routing/Layout Rules

- Do not run analog and digital signals in parallel.
- Use separate analog and digital power planes to supply power.
- Traces should run on top of the ground plane at all times.
- No trace should run over ground/power splits.
- Avoid routing at 90-degree angles.
- Minimize clock and video data trace length differences.
- Include 10 μ F and 0.1 μ F ceramic power supply bypass capacitors.
- Place the 0.1 μ F capacitor within 0.1 inches of the device power pin.
- Place the 10 μ F capacitor within 0.75 inches of the device power pin.
- For multilayer boards, use a large ground plane to help dissipate heat.
- For two-layer boards, use a ground plane that extends beyond the device body by at least 0.5 inches on all sides. Include a metal paddle under the device on the top layer.
- Minimize all trace lengths to reduce series inductance.

Thermal Considerations

Since the interior of most systems, such as set-top boxes, TVs, and DVD players are at +70°C; consideration must be given to providing an adequate heat sink for the device package for maximum heat dissipation. When designing a system board, determine how much power

each device dissipates. Ensure that devices of high power are not placed in the same location, such as directly above (top plane) and below (bottom plane) each other on the PCB.

PCB Thermal Layout Considerations

- Understand the system power requirements and environmental conditions.
- Maximize thermal performance of the PCB.
- Consider using 70 μ m of copper for high-power designs.
- Make the PCB as thin as possible by reducing FR4 thickness.
- Use vias in power pad to tie adjacent layers together.
- Remember that baseline temperature is a function of board area, not copper thickness.
- Modeling techniques can provide a first-order approximation.

Power Dissipation

Consider the FMS6141's output drive configuration when calculating overall power dissipation. Care must be taken not to exceed the maximum die junction temperature. The following example can be used to calculate the FMS6141's power dissipation and internal temperature rise.

$$T_J = T_A + P_{\text{CHANNEL}} \Theta_{JA}$$

where $P_{\text{CHANNEL}} = V_{CC} \cdot I_{CH} + (V_O^2/R_L)$

$$V_O = 2V_{IN} + 0.280V$$

$$I_{CH} = I_{CC} + (V_O/R_L)$$

V_{IN} = RMS value of input signal

$$I_{CC} = 7mA$$

$$V_S = 5V$$

$$R_L = \text{channel load resistance}$$

The FMS6141 is specified to operate with output currents typically less than 50 mA, which is more than sufficient for a dual (75 Ω) video load. The internal amplifiers of the FMS6141 are current limited to a maximum of 100 mA and can withstand a brief-duration short-circuit condition, but this capability is not guaranteed.

Physical Dimensions

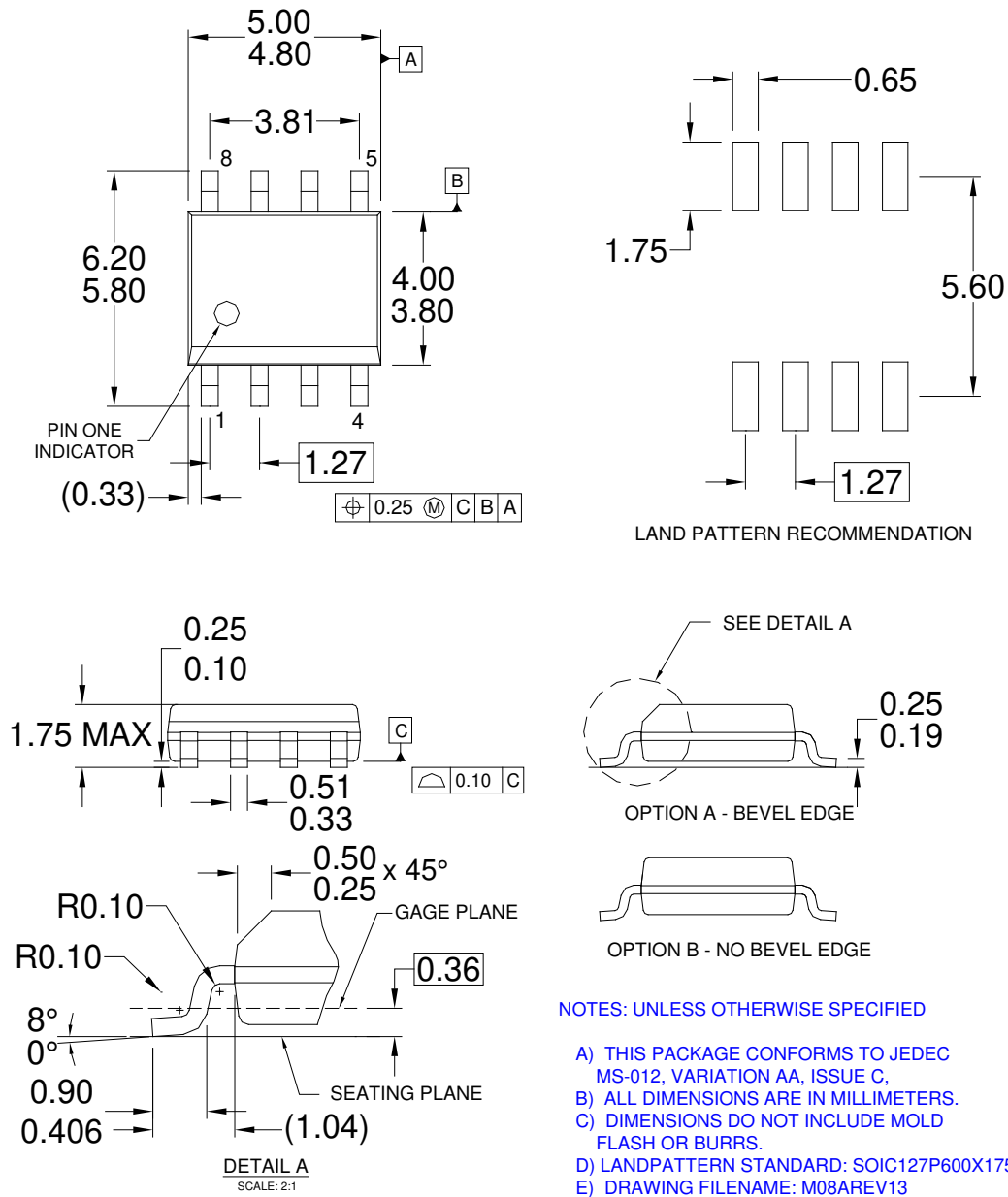
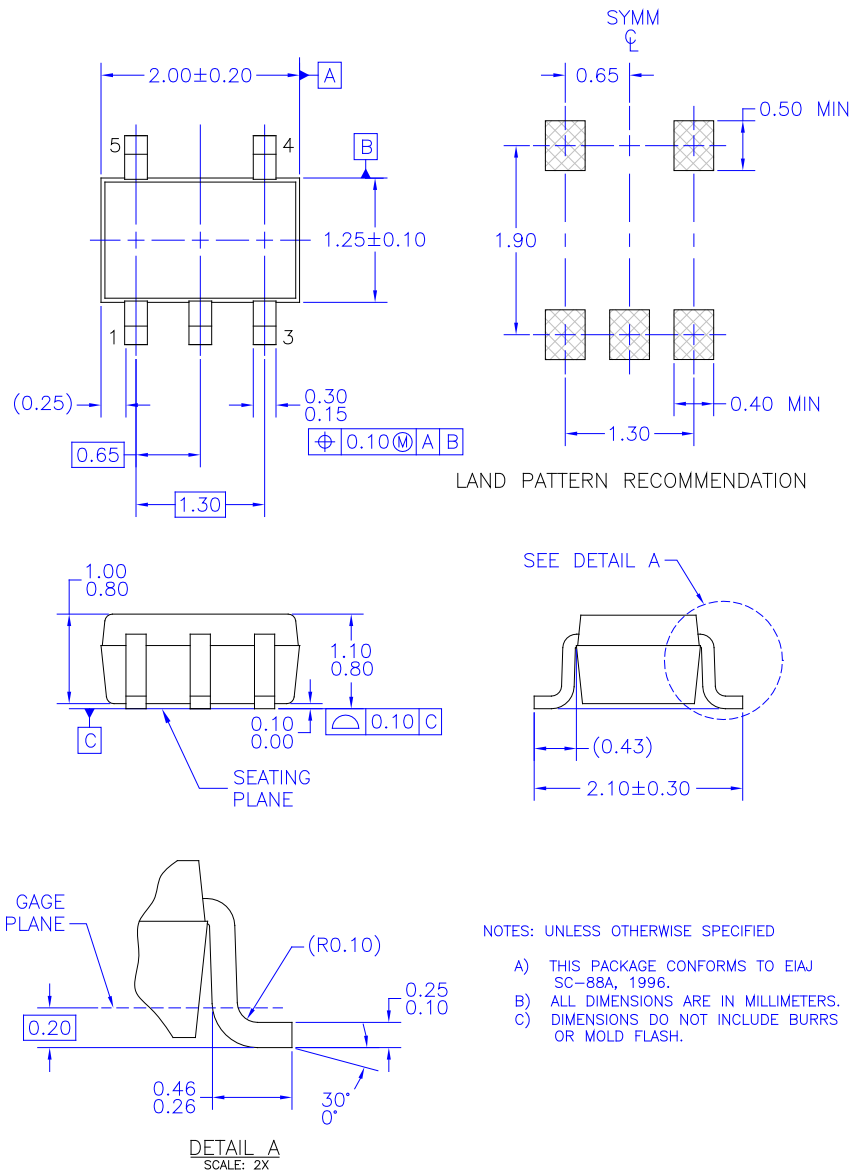

Figure 12. SOIC-8 Package

Package drawings are provided as a service to customers considering ON Semiconductor components. Drawings may change in any manner without notice. Please note the revision and/or date on the drawing and contact an ON Semiconductor representative to verify or obtain the most recent revision. Package specifications do not expand the terms of ON Semiconductor's worldwide terms and conditions, specifically the warranty therein, which covers ON Semiconductor products.

Physical Dimensions (Continued)



MAA05AREV5

Figure 13. SC70-5 Package

Package drawings are provided as a service to customers considering ON Semiconductor components. Drawings may change in any manner without notice. Please note the revision and/or date on the drawing and contact an ON Semiconductor representative to verify or obtain the most recent revision. Package specifications do not expand the terms of ON Semiconductor's worldwide terms and conditions, specifically the warranty therein, which covers ON Semiconductor products.

ON Semiconductor and the ON Semiconductor logo are trademarks of Semiconductor Components Industries, LLC dba ON Semiconductor or its subsidiaries in the United States and/or other countries. ON Semiconductor owns the rights to a number of patents, trademarks, copyrights, trade secrets, and other intellectual property. A listing of ON Semiconductor's product/patent coverage may be accessed at www.onsemi.com/site/pdf/Patent-Marking.pdf. ON Semiconductor reserves the right to make changes without further notice to any products herein. ON Semiconductor makes no warranty, representation or guarantee regarding the suitability of its products for any particular purpose, nor does ON Semiconductor assume any liability arising out of the application or use of any product or circuit, and specifically disclaims any and all liability, including without limitation special, consequential or incidental damages. Buyer is responsible for its products and applications using ON Semiconductor products, including compliance with all laws, regulations and safety requirements or standards, regardless of any support or applications information provided by ON Semiconductor. "Typical" parameters which may be provided in ON Semiconductor data sheets and/or specifications can and do vary in different applications and actual performance may vary over time. All operating parameters, including "Typicals" must be validated for each customer application by customer's technical experts. ON Semiconductor does not convey any license under its patent rights nor the rights of others. ON Semiconductor products are not designed, intended, or authorized for use as a critical component in life support systems or any FDA Class 3 medical devices or medical devices with a same or similar classification in a foreign jurisdiction or any devices intended for implantation in the human body. Should Buyer purchase or use ON Semiconductor products for any such unintended or unauthorized application, Buyer shall indemnify and hold ON Semiconductor and its officers, employees, subsidiaries, affiliates, and distributors harmless against all claims, costs, damages, and expenses, and reasonable attorney fees arising out of, directly or indirectly, any claim of personal injury or death associated with such unintended or unauthorized use, even if such claim alleges that ON Semiconductor was negligent regarding the design or manufacture of the part. ON Semiconductor is an Equal Opportunity/Affirmative Action Employer. This literature is subject to all applicable copyright laws and is not for resale in any manner.

PUBLICATION ORDERING INFORMATION

LITERATURE FULFILLMENT:

Literature Distribution Center for ON Semiconductor
 19521 E. 32nd Pkwy, Aurora, Colorado 80011 USA
Phone: 303-675-2175 or 800-344-3860 Toll Free
 USA/Canada
Fax: 303-675-2176 or 800-344-3867 Toll Free USA/Canada
Email: orderlit@onsemi.com

N. American Technical Support: 800-282-9855 Toll Free
 USA/Canada.
Europe, Middle East and Africa Technical Support:
 Phone: 421 33 790 2910
Japan Customer Focus Center
 Phone: 81-3-5817-1050

ON Semiconductor Website: www.onsemi.com
Order Literature: <http://www.onsemi.com/orderlit>
 For additional information, please contact your local Sales Representative