

Chipsmall Limited consists of a professional team with an average of over 10 year of expertise in the distribution of electronic components. Based in Hongkong, we have already established firm and mutual-benefit business relationships with customers from,Europe,America and south Asia,supplying obsolete and hard-to-find components to meet their specific needs.

With the principle of “Quality Parts,Customers Priority,Honest Operation,and Considerate Service”,our business mainly focus on the distribution of electronic components. Line cards we deal with include Microchip,ALPS,ROHM,Xilinx,Pulse,ON,Everlight and Freescale. Main products comprise IC,Modules,Potentiometer,IC Socket,Relay,Connector.Our parts cover such applications as commercial,industrial, and automotives areas.

We are looking forward to setting up business relationship with you and hope to provide you with the best service and solution. Let us make a better world for our industry!



## Contact us

Tel: +86-755-8981 8866 Fax: +86-755-8427 6832

Email & Skype: info@chipsmall.com Web: www.chipsmall.com

Address: A1208, Overseas Decoration Building, #122 Zhenhua RD., Futian, Shenzhen, China

# FP1 108L1 and FP1 108L2

## High frequency, high current power inductors



### Description

- High current carrying capacity
- Low core loss
- Ultra low DCR
- Inductance range from 105nH to 150nH
- Current range from 48 to 81 amps
- 11.0 x 8.2mm footprint surface mount package in an 8.3mm height
- Ferrite core material
- Halogen free, lead free, RoHS compliant

### Applications

- Servers
- Multi-phase and Vcore regulators
- Voltage Regulator Modules (VRMs)
- Desktop VRMs and EVRDs
- Data networking and storage systems
- Graphics cards and battery power systems
- Point-of-Load modules

### Environmental Data

- Storage temperature range (Component): -40°C to +125°C
- Operating temperature range: -40°C to +125°C (ambient + self-temperature rise)
- Solder reflow temperature: J-STD-020D compliant



**Product Specifications**

Part Number <sup>8</sup>	OCL <sup>1</sup> (nH) ±10%	FLL <sup>2</sup> (nH) minimum	I <sub>rms</sub> <sup>3</sup> (amps)	I <sub>sat</sub> <sup>1</sup> <sup>4</sup> (amps)	I <sub>sat</sub> <sup>2</sup> <sup>5</sup> (amps)	I <sub>sat</sub> <sup>3</sup> <sup>6</sup> (amps)	DCR (mΩ) ±10% @ 20°C	K-factor <sup>7</sup>
<b>L1 Version</b>								
FP1108L1-R105-R	105	76	64	81	77	72	0.10	422
FP1108L1-R150-R	150	108	64	57	49	45	0.10	422
FP1108L1-R180-R	180	129	64	47	41	37	0.10	422
<b>L2 Version</b>								
FP1108L2-R150-R	150	108	48	55	50	46	0.18	390

1. Open Circuit Inductance (OCL) Test Parameters: 100kHz, 0.1Vrms, 0.0Adc, @ +25°C
2. Full Load Inductance (FLL) Test Parameters: 100kHz, 0.1Vrms, @ I<sub>sat</sub>1, @ +25°C
3. I<sub>rms</sub>: DC current for an approximate temperature rise of 40°C without core loss. Derating is necessary for AC currents. PCB layout, trace thickness and width, air-flow, and proximity of other heat generating components will affect the temperature rise. It is recommended that the temperature of the part not exceed 125°C under worst case operating conditions verified in the end application.

4. I<sub>sat</sub>1: Peak current for approximately 20% rolloff @ +25°C
5. I<sub>sat</sub>2: Peak current for approximately 20% rolloff @ +75°C
6. I<sub>sat</sub>3: Peak current for approximately 20% rolloff @ +100°C
7. K-factor: Used to determine B<sub>p-p</sub> for core loss (see graph). B<sub>p-p</sub> = K \* L \* ΔI \* 10<sup>-3</sup> B<sub>p-p</sub>; (Gauss), K: (K-factor from table), L: (Inductance in nH), ΔI (Peak to peak ripple current in Amps).
8. Part Number Definition: FP1108Lx-Rxxx-R  
FP1108L = Product code and size  
x= Version indicator  
Rxxx= inductance value in μH, R= decimal point ,  
-R suffix = RoHS compliant

**Dimensions (mm)**

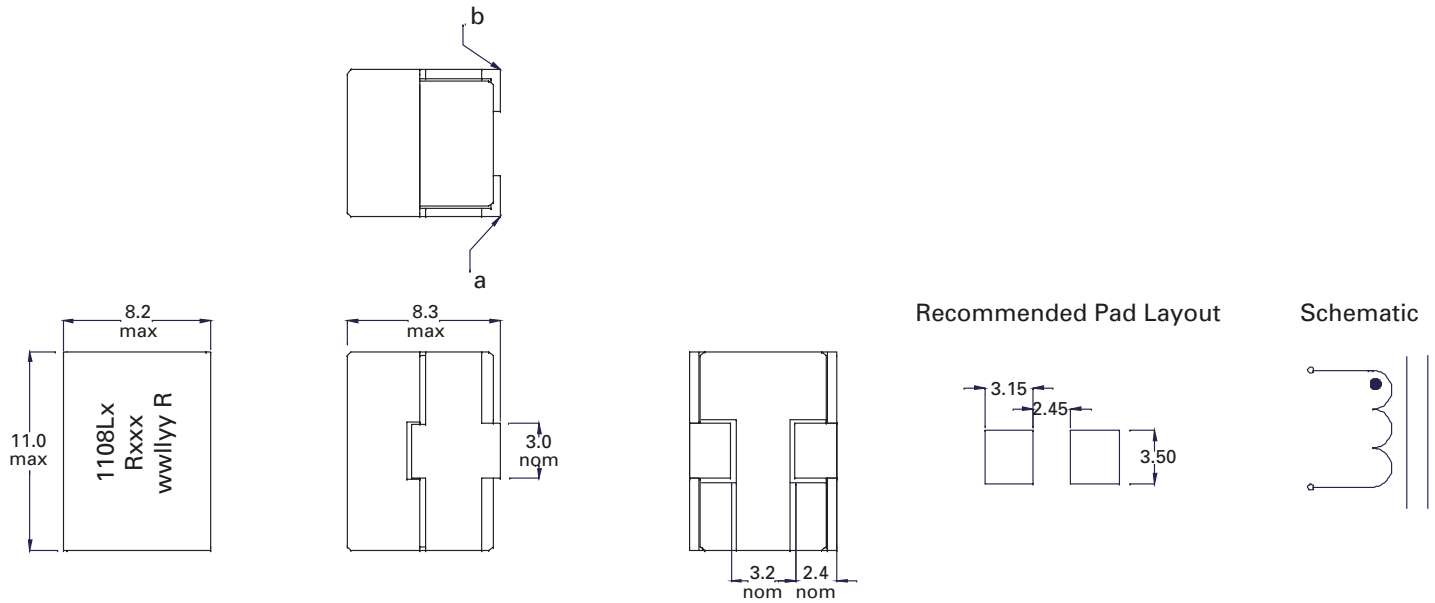

Part marking: 1108Lx (x = Version indicator), Rxxx = Inductance value in uH (R= decimal point)  
wwlllyy = date code, R = revision level  
All soldering surfaces to be coplanar within 0.1 millimeters  
PCB tolerances are ±0.1 millimeters unless otherwise specified  
DCR measured from point "a" to point "b"  
Do not route traces or vias underneath the inductor

**Packaging information (mm)**

Supplied in tape and reel packaging, 450 parts per 13" diameter reel

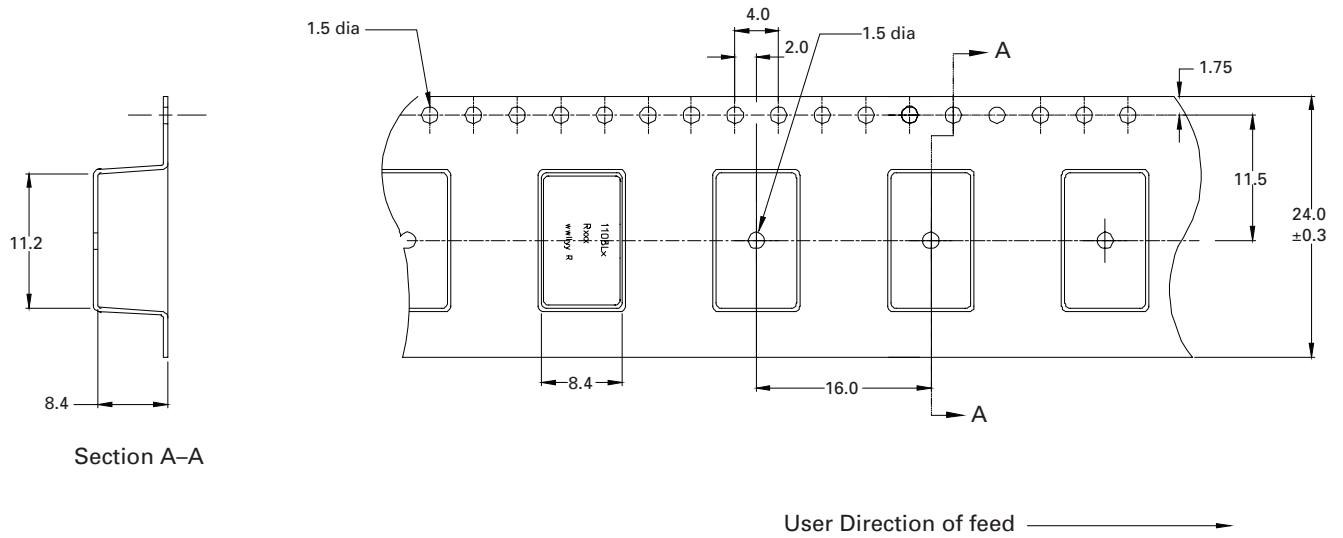

**Temperature rise vs. total loss**

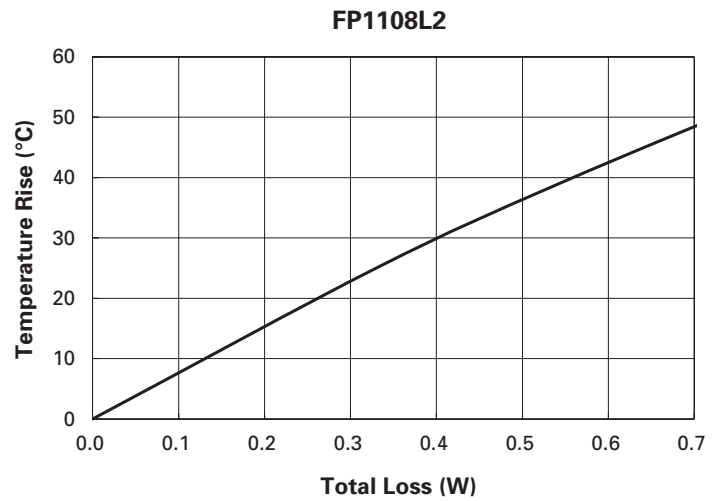
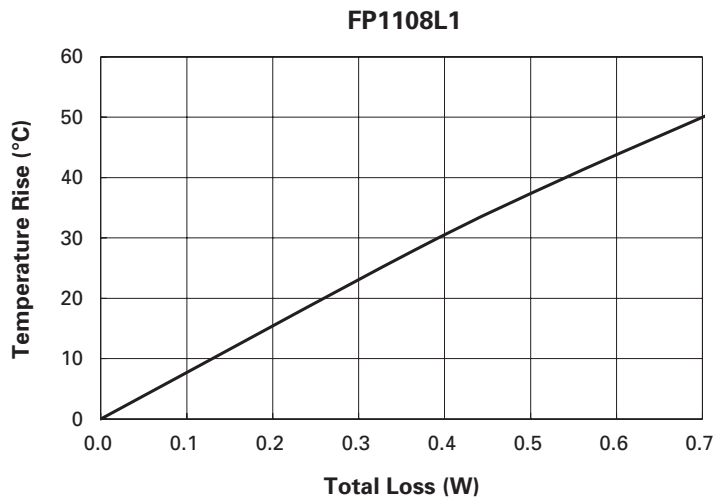

Core loss vs.  $B_{p-p}$

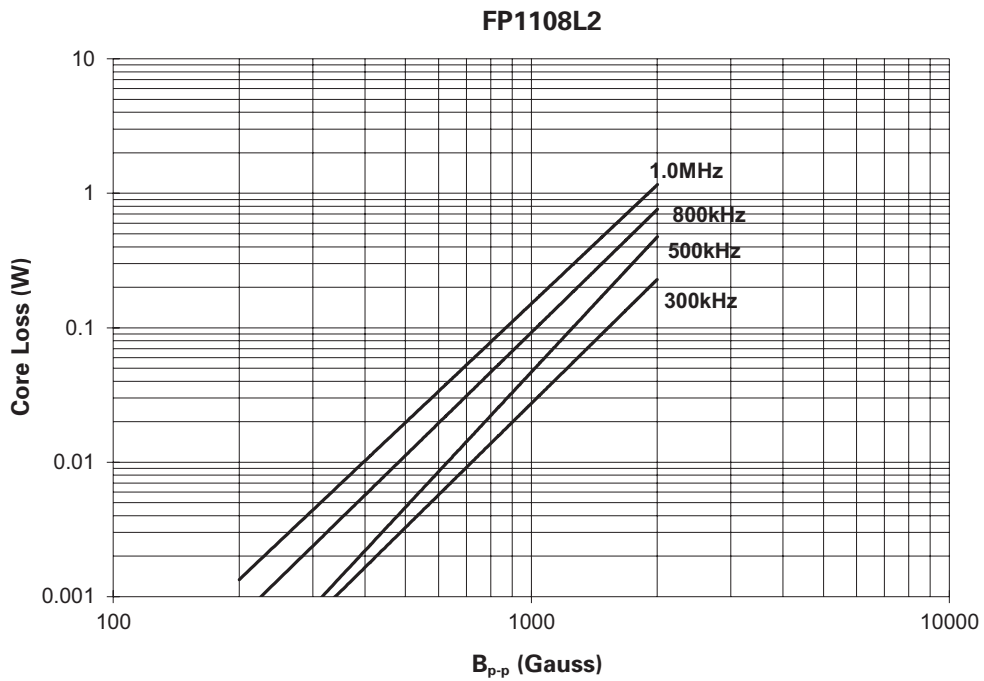
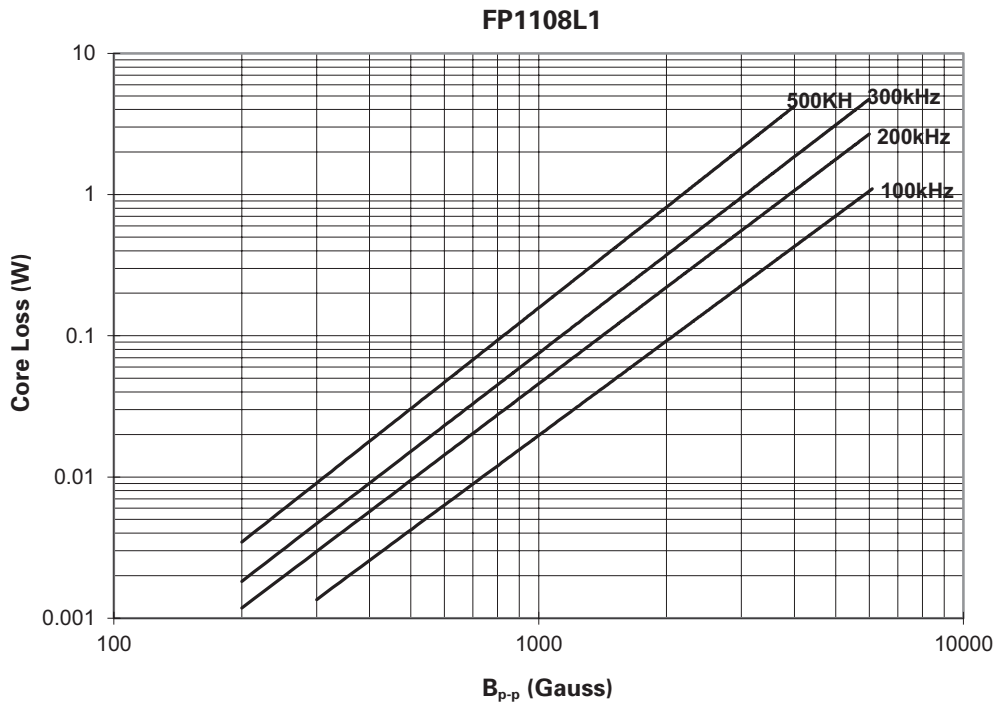

Inductance characteristics

FP1108L1-R105-R

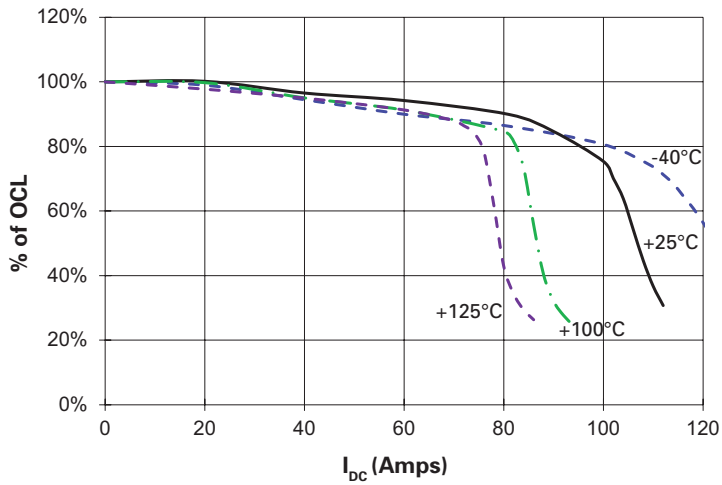

FP1108L1-R150-R

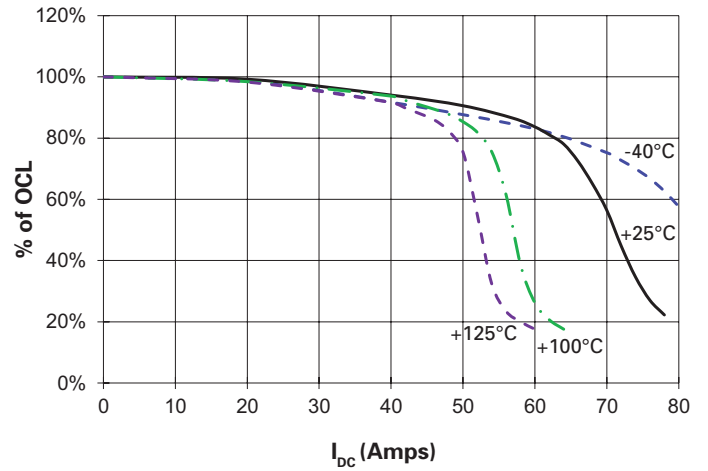

FP1108L1-R180-R

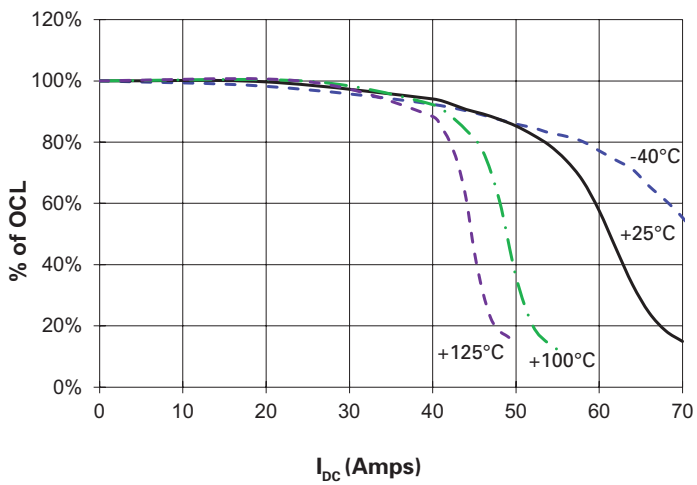

FP1108L2-R150-R

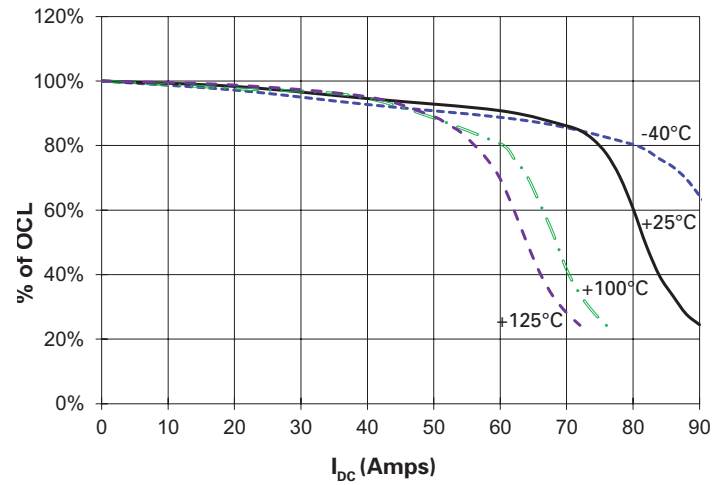

**Solder reflow profile**

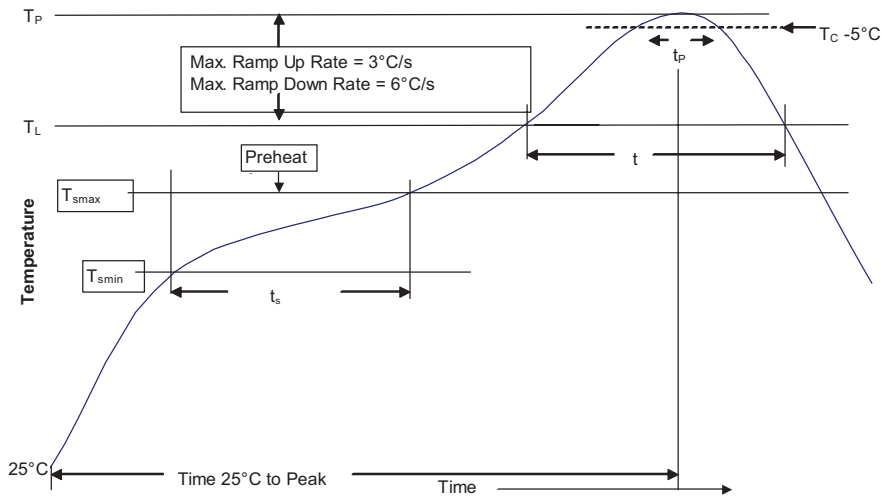

**Table 1 - Standard SnPb Solder ( $T_c$ )**

Package Thickness	Volume mm <sup>3</sup> <350	Volume mm <sup>3</sup> ≥350
<2.5mm)	235°C	220°C
≥2.5mm	220°C	220°C

**Table 2 - Lead (Pb) Free Solder ( $T_c$ )**

Package Thickness	Volume mm <sup>3</sup> <350	Volume mm <sup>3</sup> 350 - 2000	Volume mm <sup>3</sup> >2000
<1.6mm	260°C	260°C	260°C
1.6 - 2.5mm	260°C	250°C	245°C
>2.5mm	250°C	245°C	245°C

**Reference JDEC J-STD-020D**

Profile Feature	Standard SnPb Solder	Lead (Pb) Free Solder
Preheat and Soak		
• Temperature min. ( $T_{smin}$ )	100°C	150°C
• Temperature max. ( $T_{smax}$ )	150°C	200°C
• Time ( $T_{smin}$ to $T_{smax}$ ) ( $t_s$ )	60-120 Seconds	60-120 Seconds
Average ramp up rate $T_{smax}$ to $T_p$	3°C/ Second Max.	3°C/ Second Max.
Liquidous temperature ( $T_L$ )	183°C	217°C
Time at liquidous ( $t_L$ )	60-150 Seconds	60-150 Seconds
Peak package body temperature ( $T_p$ )*	Table 1	Table 2
Time ( $t_p$ )** within 5 °C of the specified classification temperature ( $T_c$ )	20 Seconds**	30 Seconds**
Average ramp-down rate ( $T_p$ to $T_{smax}$ )	6°C/ Second Max.	6°C/ Second Max.
Time 25°C to Peak Temperature	6 Minutes Max.	8 Minutes Max.

\* Tolerance for peak profile temperature ( $T_p$ ) is defined as a supplier minimum and a user maximum.  
\*\* Tolerance for time at peak profile temperature ( $t_p$ ) is defined as a supplier minimum and a user maximum.

Life Support Policy: Eaton does not authorize the use of any of its products for use in life support devices or systems without the express written approval of an officer of the Company. Life support systems are devices which support or sustain life, and whose failure to perform, when properly used in accordance with instructions for use provided in the labeling, can be reasonably expected to result in significant injury to the user.

Eaton reserves the right, without notice, to change design or construction of any products and to discontinue or limit distribution of any products. Eaton also reserves the right to change or update, without notice, any technical information contained in this bulletin.

**Eaton**  
Electronics Division  
1000 Eaton Boulevard  
Cleveland, OH 44122  
United States  
www.eaton.com/elx

© 2015 Eaton  
All Rights Reserved  
Printed in USA  
Publication No. 10448 BU-MC15030  
October 2015

Eaton is a registered trademark.

All other trademarks are property of their respective owners.