



Chipsmall Limited consists of a professional team with an average of over 10 year of expertise in the distribution of electronic components. Based in Hongkong, we have already established firm and mutual-benefit business relationships with customers from,Europe,America and south Asia,supplying obsolete and hard-to-find components to meet their specific needs.

With the principle of "Quality Parts,Customers Priority,Honest Operation,and Considerate Service",our business mainly focus on the distribution of electronic components. Line cards we deal with include Microchip,ALPS,ROHM,Xilinx,Pulse,ON,Everlight and Freescale. Main products comprise IC,Modules,Potentiometer,IC Socket,Relay,Connector.Our parts cover such applications as commercial,industrial, and automotives areas.

We are looking forward to setting up business relationship with you and hope to provide you with the best service and solution. Let us make a better world for our industry!



Contact us

Tel: +86-755-8981 8866 Fax: +86-755-8427 6832

Email & Skype: info@chipsmall.com Web: www.chipsmall.com

Address: A1208, Overseas Decoration Building, #122 Zhenhua RD., Futian, Shenzhen, China





Is Now Part of



ON Semiconductor®

To learn more about ON Semiconductor, please visit our website at
www.onsemi.com

Please note: As part of the Fairchild Semiconductor integration, some of the Fairchild orderable part numbers will need to change in order to meet ON Semiconductor's system requirements. Since the ON Semiconductor product management systems do not have the ability to manage part nomenclature that utilizes an underscore (_), the underscore (_) in the Fairchild part numbers will be changed to a dash (-). This document may contain device numbers with an underscore (_). Please check the ON Semiconductor website to verify the updated device numbers. The most current and up-to-date ordering information can be found at www.onsemi.com. Please email any questions regarding the system integration to Fairchild_questions@onsemi.com.

ON Semiconductor and the ON Semiconductor logo are trademarks of Semiconductor Components Industries, LLC dba ON Semiconductor or its subsidiaries in the United States and/or other countries. ON Semiconductor owns the rights to a number of patents, trademarks, copyrights, trade secrets, and other intellectual property. A listing of ON Semiconductor's product/patent coverage may be accessed at www.onsemi.com/site/pdf/Patent-Marking.pdf. ON Semiconductor reserves the right to make changes without further notice to any products herein. ON Semiconductor makes no warranty, representation or guarantee regarding the suitability of its products for any particular purpose, nor does ON Semiconductor assume any liability arising out of the application or use of any product or circuit, and specifically disclaims any and all liability, including without limitation special, consequential or incidental damages. Buyer is responsible for its products and applications using ON Semiconductor products, including compliance with all laws, regulations and safety requirements or standards, regardless of any support or applications information provided by ON Semiconductor. "Typical" parameters which may be provided in ON Semiconductor data sheets and/or specifications can and do vary in different applications and actual performance may vary over time. All operating parameters, including "Typicals" must be validated for each customer application by customer's technical experts. ON Semiconductor does not convey any license under its patent rights nor the rights of others. ON Semiconductor products are not designed, intended, or authorized for use as a critical component in life support systems or any FDA Class 3 medical devices or medical devices with a same or similar classification in a foreign jurisdiction or any devices intended for implantation in the human body. Should Buyer purchase or use ON Semiconductor products for any such unintended or unauthorized application, Buyer shall indemnify and hold ON Semiconductor and its officers, employees, subsidiaries, affiliates, and distributors harmless against all claims, costs, damages, and expenses, and reasonable attorney fees arising out of, directly or indirectly, any claim of personal injury or death associated with such unintended or unauthorized use, even if such claim alleges that ON Semiconductor was negligent regarding the design or manufacture of the part. ON Semiconductor is an Equal Opportunity/Affirmative Action Employer. This literature is subject to all applicable copyright laws and is not for resale in any manner.



ON Semiconductor®

October 2016

FPF2895 28 V / 5 A Rated Current Limit Switch with OVP and TRCB

Features

- 28 V / 5 A Capability
- Wide Input Voltage Range: 4 V ~ 22 V
- Ultra Low On-Resistance
 - Typ. 27 mΩ at 5 V and 25 °C
- Adjustable Current Limit with external RSET
 - 500 mA ~ 5 A
- Selectable OVLO with OV1 and OV2 Logic Input
 - 5.95 V ± 50 mV
 - 10 V ± 100 mV
 - 14 V ± 280 mV
 - 23 V ± 460 mV
- Selectable ON Polarity
- Selectable Over-Current Behavior
 - Auto-Restart Mode
 - Current Source Mode
- True Reverse Current Block
- Thermal Shutdown
- Open Drain Fault FLAGB Output
- UL60950-1 & IEC 60950-1 Certification 5 A Max Loading
- Robust ESD Capability
 - 2 kV HBM & 1 kV CDM
 - 15 kV Air Discharge & 8 kV Contact Discharge under IEC 61000-4-2

Description

The FPF2895 features a 28 V and 5 A rated current limit power switch, which offers Over-Current Protection (OCP), Over-Voltage Protection (OVP), and True Reverse Current Block (TRCB) to protect system. It has low On-resistance of typical 27 mΩ with WL-CSP can operate over an input voltage range of 4 V to 22 V.

The FPF2895 supports ±10% of current limit accuracy, over-current range of 500 mA to 5 A, flexible operations such as selectable OVP, selectable ON polarity and selectable OCP behavior, which can be optimized according to system requirements.

The FPF2895 is available in a 24-bump, 1.67 mm x 2.60 mm Wafer-Level Chip-Scale Package (WL-CSP) with 0.4 mm pitch.

Applications

- Laptop, Desktop Computing and Monitor
- Power Accessories

Related Resources

www.fairchildsemi.com

Ordering Information

Part Number	Operating Temperature Range	Top Mark	Package	Packing Method
FPF2895UCX	-40°C – +85°C	T9	24-Ball, 0.4 mm Pitch WLCSP	Tape & Reel

FPF2895 — 28 V/5 A Rated Current Limit Switch with OVP and TRCB

Application Diagram

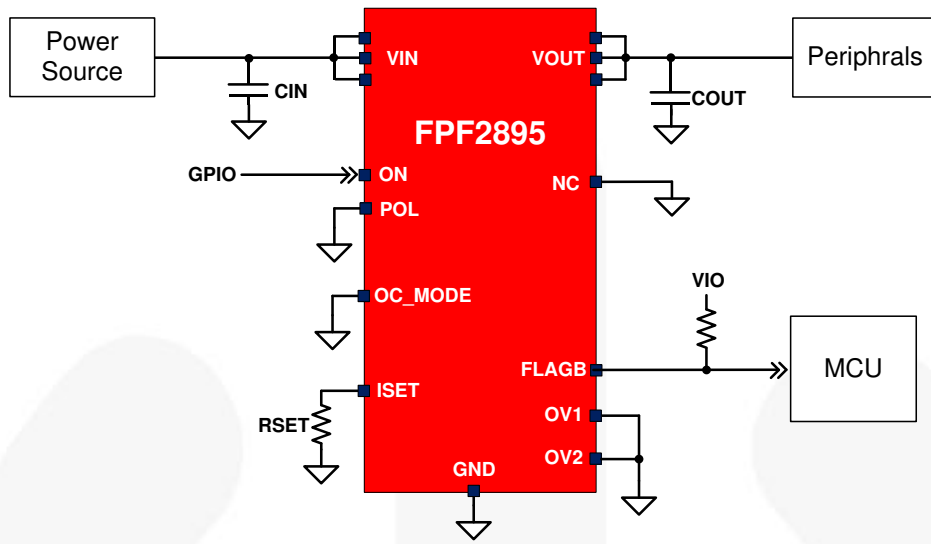

Figure 1. Typical Application

Block Diagram

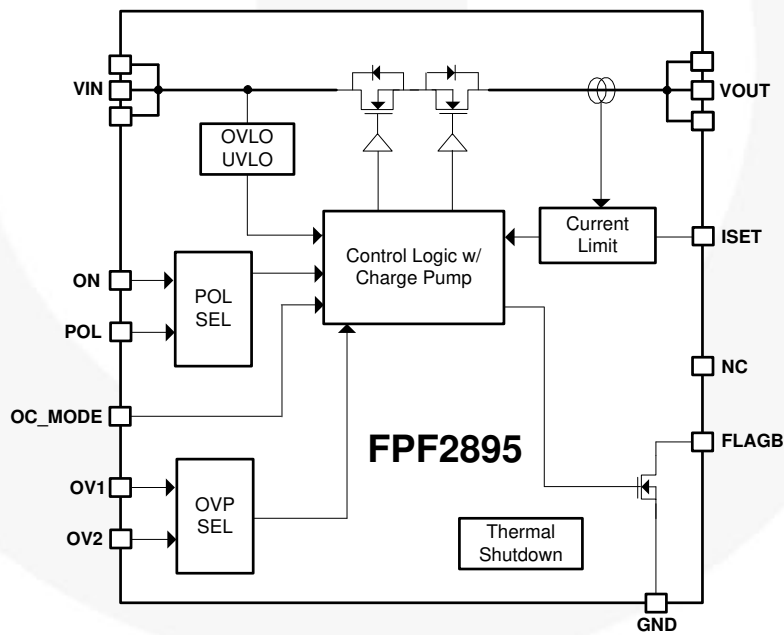

Figure 2. Functional Block Diagram

Pin Configuration

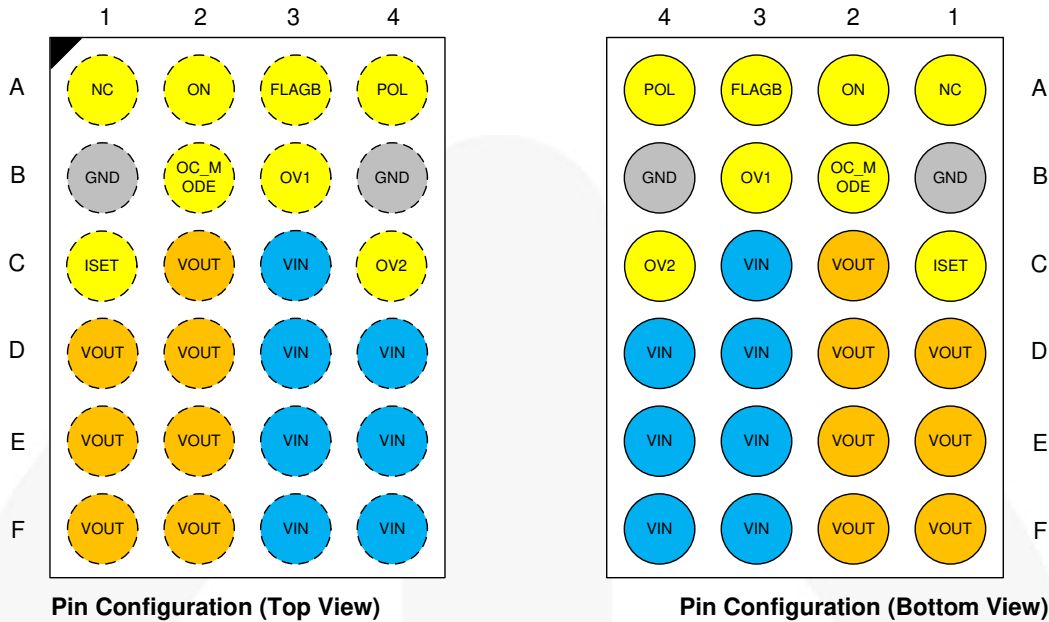

Figure 3. 24 Ball WL_CSP, 4 x 6 Array, 0.4 mm Pitch, 250 μm Ball

Pin Definitions

Name	Bump	Type	Description
VIN	C3, D3, D4, E3, E4, F3, F4	Input/Supply	Switch Input and Device Supply
VOUT	C2, D1, D2, E1, E2, F1, F2	Output	Switch Output to Load
NC	A1	Dummy	Recommended to connect to GND
ON	A2	Input	Internal pull-down resistor of 5 MΩ is included. Active polarity is depending on POL state. ⁽¹⁾
POL	A4	Input	Enable Polarity Selection. Internal pull-up of 5 MΩ is included. HIGH (or Floating): Active LOW LOW: Active HIGH ⁽¹⁾
FLAGB	A3	Output	Active LOW, open drain output indicates an over-current, under-voltage, over-voltage, or over-temperature state.
ISET	C1	Input	A resistor from ISET to ground set the current limit for the switch. See below selection table 1.
OC_MODE	B2	Input	OCP behavior can be selected. Internal pull-up of 5 MΩ is included. HIGH (or Floating): Auto-restart mode during over-current condition. LOW: Current source mode during over-current condition. ⁽¹⁾
OV1	B3	Input	Over-Voltage Selection Input 1. Internal pull-up of 5 MΩ is included and see below selection table 2. ⁽¹⁾
OV2	C4	Input	Over-Voltage Selection Input 2. Internal pull-up of 5 MΩ is included and see Table 2. ⁽¹⁾
GND	B1, B4	GND	Device Ground

Note:

- To avoid external noise influence when floating, recommend to connect these pins to a certain level.

Absolute Maximum Ratings

Stresses exceeding the absolute maximum ratings may damage the device. The device may not function or be operable above the recommended operating conditions and stressing the parts to these levels is not recommended. In addition, extended exposure to stresses above the recommended operating conditions may affect device reliability. The absolute maximum ratings are stress ratings only.

Symbol	Parameters	Min.	Max.	Unit	
V _{IN} , V _{OUT}	V _{IN} , V _{OUT} to GND	-0.3	28.0	V	
V _{PIN}	ON, POL, OC_MODE, ISET, FLAGB and OV _n to GND	-0.3	6.0	V	
I _{SW}	Continuous Switch Current		5.5	A	
t _{PD}	Total Power Dissipation at T _A =25°C		2.08	W	
T _{STG}	Storage Junction Temperature	-65	+150	°C	
T _J	Operating Junction Temperature		+150	°C	
T _L	Lead Temperature (Soldering, 10 Seconds)		+260	°C	
Θ _{JA}	Thermal Resistance, Junction-to-Ambient (1 in. ² pad of 2 oz. copper)		60 ⁽²⁾	°C/W	
ESD	Electrostatic Discharge Capability	Human Body Model, ANSI/ESDA/JEDEC JS-001	2		kV
		Charged Device Model, JESD22-C101	1		
	IEC61000-4-2 System Level	Air Discharge	15		
		Contact Discharge	8		

Note:

- Measured using 2S2P JEDEC std. PCB.

Recommended Operating Conditions

The Recommended Operating Conditions table defines the conditions for actual device operation. Recommended operating conditions are specified to ensure optimal performance to the datasheet specifications. ON does not recommend exceeding them or designing to Absolute Maximum Ratings.

Symbol	Parameter	Min.	Max.	Unit
V _{IN}	Supply Voltage	4.0	22.0	V
C _{IN} / C _{OUT}	Input and Output Capacitance	1.0		μF
T _A	Ambient Operating Temperature	-40	+85	°C

Electrical Characteristics

Unless otherwise noted, $V_{IN}=4$ to 22 V, $T_A=-40$ to 85°C; typical values are at $V_{IN}=5$ V, $C_{IN}=C_{OUT}=1$ μ F, ON=HIGH, POL=OV1=OV2=OC_MODE=GND and $T_A = 25^\circ\text{C}$.

Symbol	Parameter	Conditions	Min.	Typ.	Max.	Unit	
Basic Operation							
V_{IN}	Input Voltage		4		22	V	
I_{SD_IN}	V_{IN} Shutdown Current	$V_{ON}=\text{OFF}$, $V_{IN}=5.5$ V, $V_{OUT}=\text{Short to GND}$		75	100	μ A	
I_Q	Quiescent Current	$I_{OUT}=0$ mA, $V_{ON}=\text{ON}$	$V_{IN}=5$ V	270	330	μ A	
			$V_{IN}=12$ V	300	400		
			$V_{IN}=20$ V	350	450		
R_{ON}	On Resistance	$T_A=25^\circ\text{C}$, $I_{OUT}=1$ A	$V_{IN}=5$ V	27	39	m Ω	
			$V_{IN}=12$ V	27	39		
			$V_{IN}=20$ V	27	39		
I_{ON}	ON Input Leakage	$V_{ON}=V_{IN}$ or GND			2	μ A	
V_{IH}	ON Input Logic High Voltage	$V_{IN}=3$ V~23 V	1.2			V	
V_{IL}	ON Input Logic Low Voltage	$V_{IN}=3$ V~23 V			0.4	V	
V_{P_LOW}	FLAGB Output Logic Low Voltage	$V_{IN}=5$ V, $I_{SINK}=5$ mA		0.1	0.2	V	
I_{LKG}	FLAGB Output High, Leakage Current	$V_{IN}=5$ V, Switch ON			1	μ A	
Protections							
I_{LIM}	Current Limit ⁽³⁾	$V_{IN}=5$ V, $V_{OUT}=4$ V, $R_{SET}=2.96$ k Ω , $T_A = -40$ to 85°C	1.35	1.50	1.65	A	
		$V_{IN}=5$ V, $V_{OUT}=4$ V, $R_{SET}=1.48$ k Ω , $T_A = -40$ to 85°C	2.7	3.0	3.3		
V_{FOLD}	ILIM Foldback Trip Voltage ⁽³⁾	V_{OUT} under ILIM Mode		2		V	
I_{FOLD}	ILIM Foldback Gain ⁽³⁾	$V_{IN}=5$ V, $V_{OUT} < V_{FOLD}$, $T_A=25^\circ\text{C}$, OC_MODE=HIGH		500		mA	
		$V_{IN}=5$ V, $V_{OUT} < V_{FOLD}$, $T_A=25^\circ\text{C}$, OC_MODE=LOW		250		mA	
V_{UVLO}	Under-Voltage Lockout	V_{IN} Increasing		2.70	2.95	V	
		V_{IN} Decreasing		2.5			
	UVLO Hysteresis			200		mV	
V_{OVLO}	Over-Voltage Lockout	OV1=LOW, OV2=LOW	V_{IN} Rising	22.54	23.00	23.46	V
			V_{IN} Falling	22.34			
		OV1=LOW, OV2=HIGH	V_{IN} Rising	9.90	10.00	10.10	
			V_{IN} Falling	9.85			
		OV1=HIGH, OV2=LOW	V_{IN} Rising	13.72	14.00	14.28	
			V_{IN} Falling	13.52			
OV1=HIGH, OV2=HIGH	V_{IN} Rising	5.90	5.95	6.00			
	V_{IN} Falling	5.85					
t_{OVP}	OVP Response Time ⁽³⁾	$R_L=100$ Ω , $C_L=0$ μ F, $V_{IN} > V_{OVLO}$ to $V_{OUT}=0.9 \times V_{IN}$			150	ns	
V_{T_RCB}	TRCB Protection Trip Point	$V_{OUT} - V_{IN}$		25	40	mV	
V_{R_RCB}	TRCB Protection, Release Point	$V_{IN} - V_{OUT}$		25	40	mV	
t_{RCB}	TRCB Response Time ⁽³⁾	$V_{IN}=5$ V, $V_{ON}=\text{HIGH/LOW}$		5		μ s	
$t_{RCB_Release}$	TRCB Release Time ⁽³⁾	$V_{IN}=5$ V, Enabled		1		μ s	
t_{OC}	Over Current Response Time ⁽³⁾	$V_{IN}=5$ V, Moderate OC		20		μ s	
		$V_{IN}=5$ V, Hard Short		5			

Electrical Characteristics

Unless otherwise noted, $V_{IN}=4$ to 22 V, $T_A=-40$ to 85°C; typical values are at $V_{IN}=5$ V, $C_{IN}=C_{OUT}=1$ μ F, ON=HIGH, POL=OV1=OV2=OC_MODE=GND and $T_A = 25^\circ$ C.

Symbol	Parameter	Conditions	Min.	Typ.	Max.	Unit
I_{SD_OUT}	VOUT Shutdown Current	$V_{ON}=OFF$, $V_{OUT}=5$ V, V_{IN} =Short to GND			2	μ A
TSD	Thermal Shutdown ⁽³⁾	Shutdown Threshold		150		°C
		Hysteresis		20		
Dynamic Behavior						
t_{DON}	Delay On Time	$R_L=100$ Ω , $C_L=1$ μ F		1		ms
t_R	V _{OUT} Rise Time	$R_L=100$ Ω , $C_L=1$ μ F		1		ms
t_{ON}	Turn-On Time	$R_L=100$ Ω , $C_L=1$ μ F		2		ms
t_{DOFF}	Delay Off Time	$R_L=100$ Ω , $C_L=1$ μ F		10		μ s
t_F	V _{OUT} Fall Time	$R_L=100$ Ω , $C_L=1$ μ F		200		μ s
t_{OFF}	Turn-Off Time	$R_L=100$ Ω , $C_L=1$ μ F		210		μ s
t_{BLANK}	Over-Current Blanking Time ⁽³⁾	OC_MODE=HIGH		5		ms
t_{RSTRT}	Auto-Restart Time ⁽³⁾	OC_MODE=HIGH		200		ms
t_{QUAL}	Over-Current Qualification Time ⁽³⁾	OC_MODE=LOW		5		ms
t_{DEB}	FLAGB Debounce Time ⁽³⁾	Restart-up during or after OC		3		ms
		Restart-up during or after Thermal shutdown		15		
		Restart-up during or after UVLO		1		

Note:

3. Guaranteed by characterization and design, not production test.

Setting Current Limit

FPF2895 current limit is set with an external resistor connected between I_{SET} and GND. This resistor is selected using the following equation:

$$R_{SET} [k\Omega] = 4448.6 / I_{LIM} [mA] \quad (1)$$

The resistor can be selected using 0. Resistor tolerance of 1% or less is recommended

Table 1. ILIM vs. RSET Look-up Table

RSET [kΩ]	ILIM [mA]		
	Min.	Typ.	Max.
8.89	450	500	550
7.41	540	600	660
6.35	630	700	770
5.56	720	800	880
4.94	810	900	990
4.45	900	1000	1100
4.04	990	1100	1210
3.71	1080	1200	1320
3.42	1170	1300	1430
3.18	1260	1400	1540
2.96	1350	1500	1650
2.78	1440	1600	1760
2.62	1530	1700	1870
2.47	1620	1800	1980
2.34	1710	1900	2090
2.22	1800	2000	2200
2.12	1890	2100	2310
2.02	1980	2200	2420
1.93	2070	2300	2530
1.85	2160	2400	2640
1.78	2250	2500	2750
1.71	2340	2600	2860
1.65	2430	2700	2970
1.59	2520	2800	3080
1.53	2610	2900	3190
1.48	2700	3000	3300
1.43	2790	3100	3410
1.39	2880	3200	3520
1.35	2970	3300	3630
1.31	3060	3400	3740
1.27	3150	3500	3850
1.24	3240	3600	3960
1.20	3330	3700	4070
1.17	3420	3800	4180
1.14	3510	3900	4290
1.11	3600	4000	4400
1.08	3690	4100	4510
1.06	3780	4200	4620
1.03	3870	4300	4730
1.01	3960	4400	4840

Table 1. ILIM vs. RSET Look-up Table (Continued)

RSET [kΩ]	ILIM [mA]		
	Min.	Typ.	Max.
0.99 ⁽⁴⁾	4050	4500	4950
0.97	4140	4600	5060
0.95	4230	4700	5170
0.93	4320	4800	5280
0.91	4410	4900	5390
0.89	4500	5000	5500

Note:

- Passed UL&CB certification with max. 5 A output current.

Table 2. OVLO Level Selection

OV1	OV2	OVLO
LOW	LOW	23 V ±460 mV
LOW	HIGH (Floating)	10 V ±100 mV
HIGH (Floating)	LOW	14 V ±280 mV
HIGH (Floating)	HIGH (Floating)	5.95 V ±50 mV

Table 3. Device Enable Polarity Selection

POL	ON	Device State	ON Polarity
LOW	LOW (Floating)	OFF	Active HIGH
LOW	HIGH	ON	
HIGH (Floating)	LOW (Floating)	ON	Active LOW
HIGH (Floating)	HIGH	OFF	

Timing Diagrams

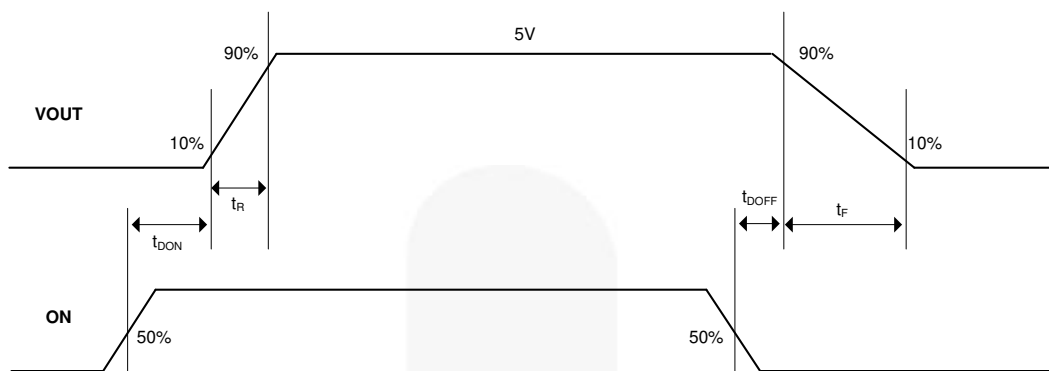

Figure 4. Normal ON/OFF Operation by ON (POL=GND)

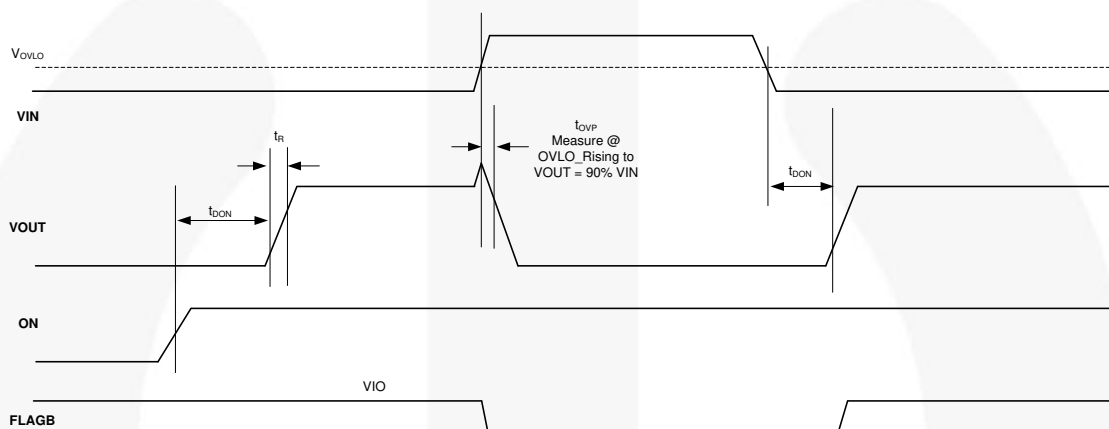

Figure 5. OVLO Operation (POL=GND & FLAGB is pulled up with an external VIO)

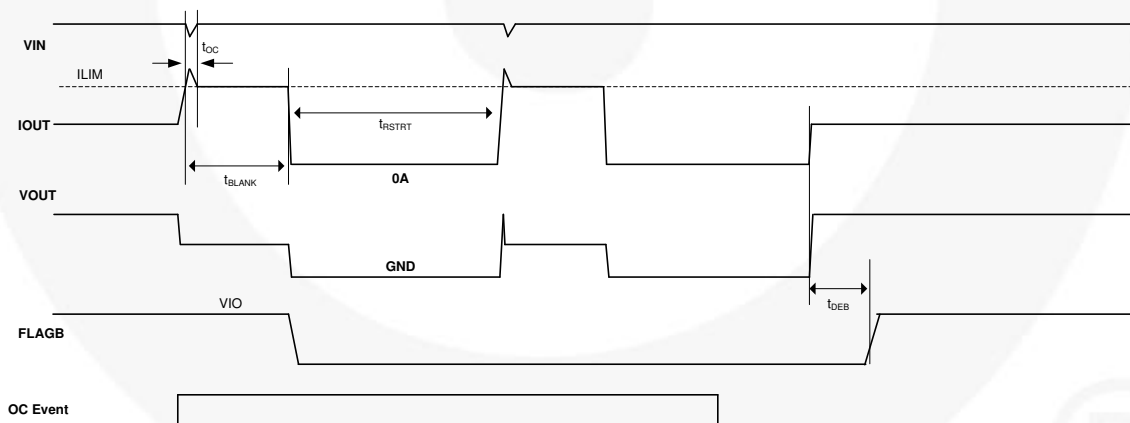

Figure 6. Current Limit Operation (OC_MODE=HIGH & FLAGB is pulled up with an external VIO)

Timing Diagrams (Continued)

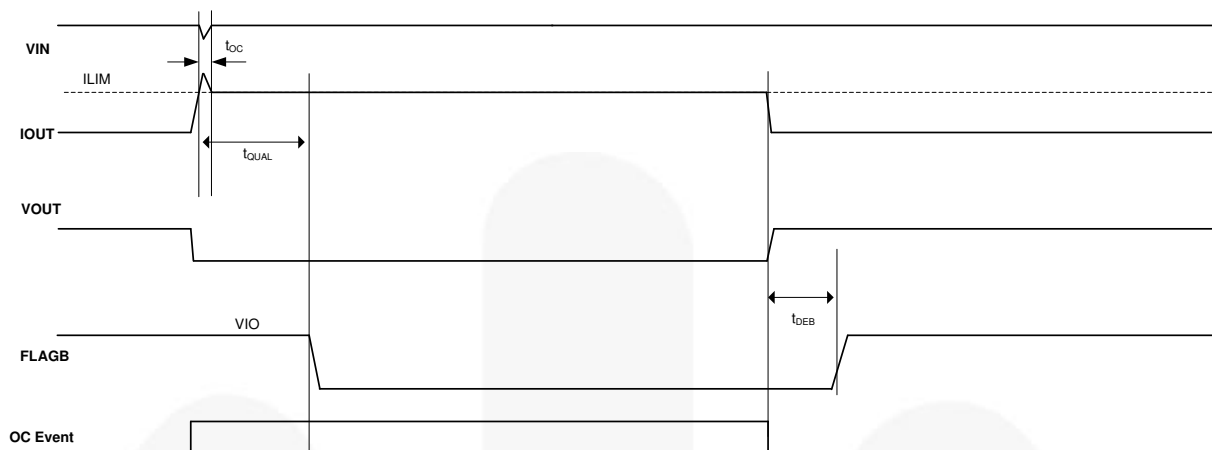

Figure 7. Current Limit Operation (OC_MODE=LOW & FLAGB is pulled up with an external VIO)

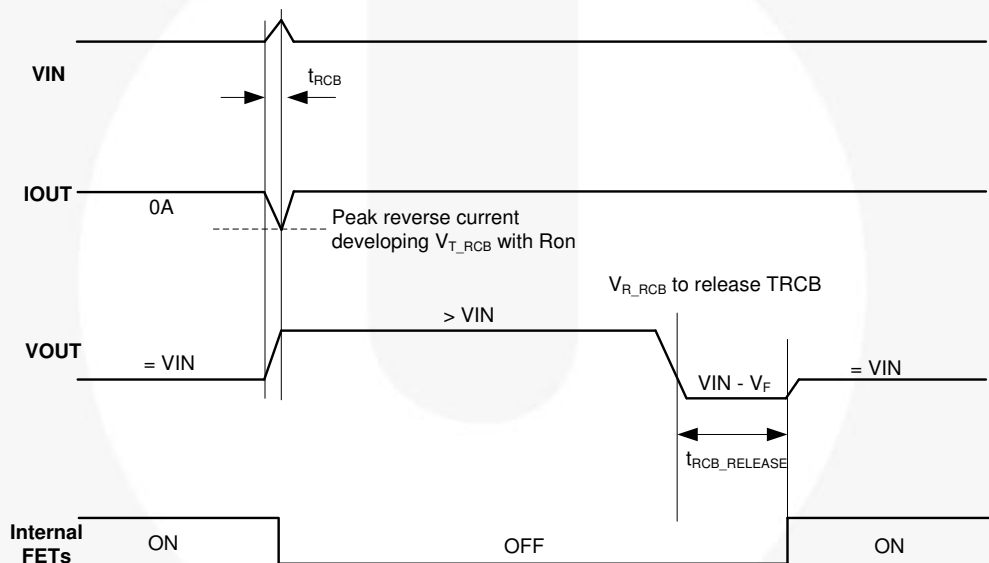
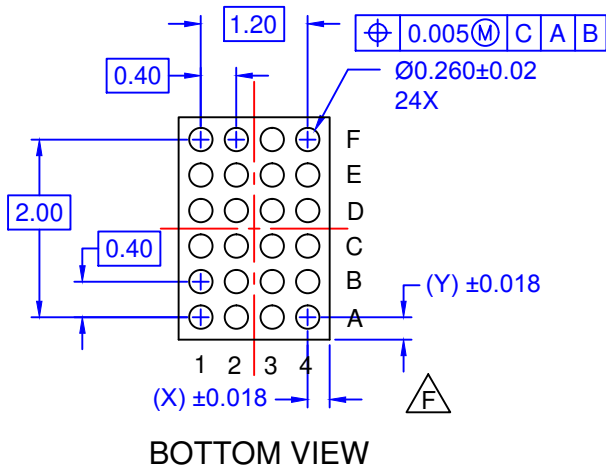
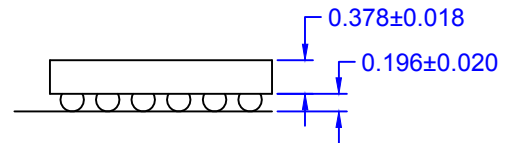
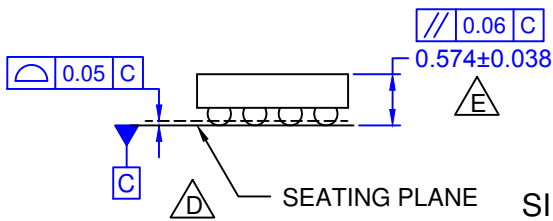
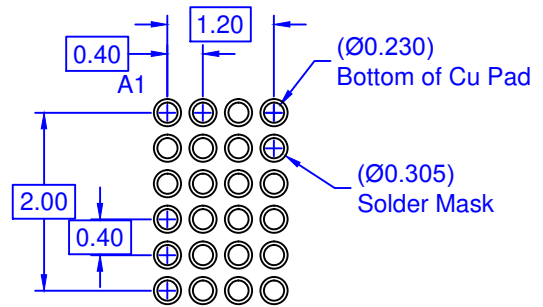
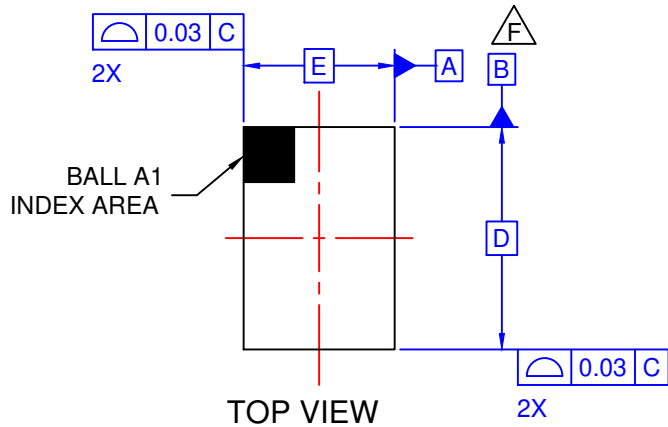

Figure 8. TRCB Operation (Device is Enabled)

The table below pertains to the Marketing outline drawing on the following page.

Product-Specific Dimensions

D	E	X	Y
2600 μm ±30 μm	1670 μm ±30 μm	235 μm ±18 μm	300 μm ±18 μm



NOTES

- A. NO JEDEC REGISTRATION APPLIES.
- B. DIMENSIONS ARE IN MILLIMETERS.
- C. DIMENSIONS AND TOLERANCE PER ASMEY14.5M, 2009.
- D. DATUM C IS DEFINED BY THE SPHERICAL CROWNS OF THE BALLS.
- E. PACKAGE NOMINAL HEIGHT IS 574 ± 38 MICRONS (536-612 MICRONS).
- F. FOR DIMENSIONS D, E, X, AND Y SEE PRODUCT DATASHEET.
- G. DRAWING FILENAME: MKT-UC024AA REV3



ON Semiconductor and  are trademarks of Semiconductor Components Industries, LLC dba ON Semiconductor or its subsidiaries in the United States and/or other countries. ON Semiconductor owns the rights to a number of patents, trademarks, copyrights, trade secrets, and other intellectual property. A listing of ON Semiconductor's product/patent coverage may be accessed at www.onsemi.com/site/pdf/Patent-Marking.pdf. ON Semiconductor reserves the right to make changes without further notice to any products herein. ON Semiconductor makes no warranty, representation or guarantee regarding the suitability of its products for any particular purpose, nor does ON Semiconductor assume any liability arising out of the application or use of any product or circuit, and specifically disclaims any and all liability, including without limitation special, consequential or incidental damages. Buyer is responsible for its products and applications using ON Semiconductor products, including compliance with all laws, regulations and safety requirements or standards, regardless of any support or applications information provided by ON Semiconductor. "Typical" parameters which may be provided in ON Semiconductor data sheets and/or specifications can and do vary in different applications and actual performance may vary over time. All operating parameters, including "Typicals" must be validated for each customer application by customer's technical experts. ON Semiconductor does not convey any license under its patent rights nor the rights of others. ON Semiconductor products are not designed, intended, or authorized for use as a critical component in life support systems or any FDA Class 3 medical devices or medical devices with a same or similar classification in a foreign jurisdiction or any devices intended for implantation in the human body. Should Buyer purchase or use ON Semiconductor products for any such unintended or unauthorized application, Buyer shall indemnify and hold ON Semiconductor and its officers, employees, subsidiaries, affiliates, and distributors harmless against all claims, costs, damages, and expenses, and reasonable attorney fees arising out of, directly or indirectly, any claim of personal injury or death associated with such unintended or unauthorized use, even if such claim alleges that ON Semiconductor was negligent regarding the design or manufacture of the part. ON Semiconductor is an Equal Opportunity/Affirmative Action Employer. This literature is subject to all applicable copyright laws and is not for resale in any manner.

PUBLICATION ORDERING INFORMATION

LITERATURE FULFILLMENT:

Literature Distribution Center for ON Semiconductor
19521 E. 32nd Pkwy, Aurora, Colorado 80011 USA
Phone: 303-675-2175 or 800-344-3860 Toll Free USA/Canada
Fax: 303-675-2176 or 800-344-3867 Toll Free USA/Canada
Email: orderlit@onsemi.com

N. American Technical Support: 800-282-9855 Toll Free
USA/Canada
Europe, Middle East and Africa Technical Support:
Phone: 421 33 790 2910
Japan Customer Focus Center
Phone: 81-3-5817-1050

ON Semiconductor Website: www.onsemi.com
Order Literature: <http://www.onsemi.com/orderlit>
For additional information, please contact your local
Sales Representative