



Chipsmall Limited consists of a professional team with an average of over 10 year of expertise in the distribution of electronic components. Based in Hongkong, we have already established firm and mutual-benefit business relationships with customers from,Europe,America and south Asia,supplying obsolete and hard-to-find components to meet their specific needs.

With the principle of “Quality Parts,Customers Priority,Honest Operation,and Considerate Service”,our business mainly focus on the distribution of electronic components. Line cards we deal with include Microchip,ALPS,ROHM,Xilinx,Pulse,ON,Everlight and Freescale. Main products comprise IC,Modules,Potentiometer,IC Socket,Relay,Connector.Our parts cover such applications as commercial,industrial, and automotives areas.

We are looking forward to setting up business relationship with you and hope to provide you with the best service and solution. Let us make a better world for our industry!



Contact us

Tel: +86-755-8981 8866 Fax: +86-755-8427 6832

Email & Skype: info@chipsmall.com Web: www.chipsmall.com

Address: A1208, Overseas Decoration Building, #122 Zhenhua RD., Futian, Shenzhen, China



THIS COPY IS PROVIDED ON A RESTRICTED BASIS AND IS NOT TO BE USED IN ANY WAY DETRIMENTAL TO THE INTERESTS OF PANDUIT CORP.

45° UP-DOWN
UTP WIRE CAP

UTP
STRAIN
RELIEF
CLIP

PROTECTIVE
WIRE CAP

NOTES:

- VISIT OUR ON-LINE CATALOG AT WWW.PANDUIT.COM FOR A LIST OF CURRENT PARTS APPLICABLE FOR USE WITH THIS PRODUCT.
- DIMENSIONS IN [] ARE METRIC.
- ALL MATERIALS AND COMPONENTS USED MEET THE MATERIAL RESTRICTIONS OF RoHS (EUROPEAN DIRECTIVE 2011/65/EU ON THE RESTRICTION OF HAZARDOUS SUBSTANCES) AS PROPOSED BY THE RoHS TECHNICAL ADAPTATION COMMITTEE.
- WEIGHT: 1.504 LBS/ 100 PCS (682g/ 100 PCS)
- PART INCLUDES:
PLUG ENCLOSURE: POLYCARBONATE W/ UL94V-0 FLAME RATING
CONTACTS & IDCs: PHOSPHOR BRONZE
- MEETS OR EXCEEDS PROPOSED TIA CATEGORY 6A, 6 AND 5E MODULAR PLUG TERMINATED LINK REQUIREMENTS WITH UP TO TWO FIELD TERMINABLE PLUGS IN LINK.
- TERMINATES 22-26AWG SOLID OR STRANDED UTP CABLE.
- SEE INSTALLATION INSTRUCTION FOR PROPER TERMINATION METHODS.
- OPERATIONAL TEMPERATURE: -40°F TO +167°F (-40°C TO +75°C)
- STORAGE TEMPERATURE: -40°F TO +167°F (-40°C TO +75°C)
- 8 POSITION, 8 WIRE UTP RJ45 PLUG W/ 45° UP/DOWN WIRE CAP ASSEMBLY, WIRE CAP LABEL IS CODED FOR T568B WIRING SCHEME.

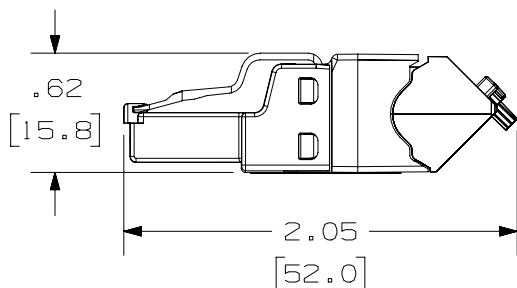
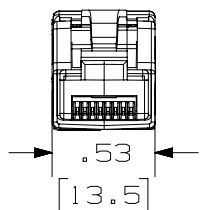

WITHOUT PROTECTIVE CAP

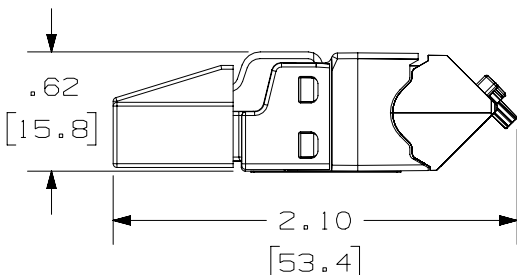
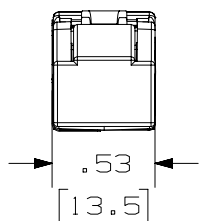

WITH PROTECTIVE CAP

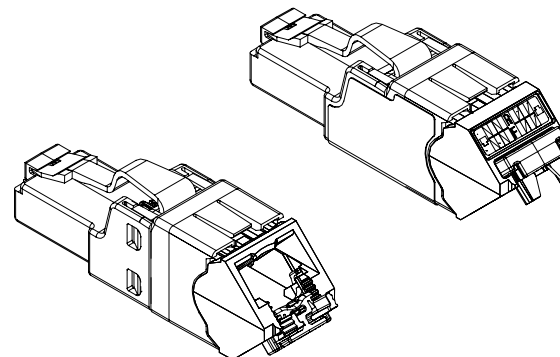

ACTUAL SIZE

PART NUMBER		FPUD6X88MTG	
TITLE		TX6A FIELD TERMINABLE UTP RJ45 PLUG W/ 45° UP/DOWN WIRE CAP ASSEMBLY	
ITEM REVISION NAME		CUSTOMER DRAWING	
DATASET FILE NAME		00163LAG-02	
MATERIAL		SEE NOTE 5	
DRAWING NUMBER		00163LAG-02	
DRAWN BY		BJN	
DATE		4-21-17	
CHK		JAV	
SCALE		FULL	
SHEET 1 OF 1		A	

REV	DATE	BY	CHK	APR	DESCRIPTION	ECN
3	3-13-18	BJN	DCS	TMBA	UPDATED	00163LAG-02
2	1-5-18	BJN	DCS	TMBA	UPDATED REVISED & REDRAWN PREVIOUS REVISIONS REMVD FOR CLARITY	00163LAG-02

A-SIZE CUSTOMER