



Chipsmall Limited consists of a professional team with an average of over 10 year of expertise in the distribution of electronic components. Based in Hongkong, we have already established firm and mutual-benefit business relationships with customers from,Europe,America and south Asia,supplying obsolete and hard-to-find components to meet their specific needs.

With the principle of “Quality Parts,Customers Priority,Honest Operation,and Considerate Service”,our business mainly focus on the distribution of electronic components. Line cards we deal with include Microchip,ALPS,ROHM,Xilinx,Pulse,ON,Everlight and Freescale. Main products comprise IC,Modules,Potentiometer,IC Socket,Relay,Connector.Our parts cover such applications as commercial,industrial, and automotives areas.

We are looking forward to setting up business relationship with you and hope to provide you with the best service and solution. Let us make a better world for our industry!



Contact us

Tel: +86-755-8981 8866 Fax: +86-755-8427 6832

Email & Skype: info@chipsmall.com Web: www.chipsmall.com

Address: A1208, Overseas Decoration Building, #122 Zhenhua RD., Futian, Shenzhen, China





Is Now Part of



ON Semiconductor®

To learn more about ON Semiconductor, please visit our website at
www.onsemi.com

ON Semiconductor and the ON Semiconductor logo are trademarks of Semiconductor Components Industries, LLC dba ON Semiconductor or its subsidiaries in the United States and/or other countries. ON Semiconductor owns the rights to a number of patents, trademarks, copyrights, trade secrets, and other intellectual property. A listing of ON Semiconductor's product/patent coverage may be accessed at www.onsemi.com/site/pdf/Patent-Marking.pdf. ON Semiconductor reserves the right to make changes without further notice to any products herein. ON Semiconductor makes no warranty, representation or guarantee regarding the suitability of its products for any particular purpose, nor does ON Semiconductor assume any liability arising out of the application or use of any product or circuit, and specifically disclaims any and all liability, including without limitation special, consequential or incidental damages. Buyer is responsible for its products and applications using ON Semiconductor products, including compliance with all laws, regulations and safety requirements or standards, regardless of any support or applications information provided by ON Semiconductor. "Typical" parameters which may be provided in ON Semiconductor data sheets and/or specifications can and do vary in different applications and actual performance may vary over time. All operating parameters, including "Typicals" must be validated for each customer application by customer's technical experts. ON Semiconductor does not convey any license under its patent rights nor the rights of others. ON Semiconductor products are not designed, intended, or authorized for use as a critical component in life support systems or any FDA Class 3 medical devices or medical devices with a same or similar classification in a foreign jurisdiction or any devices intended for implantation in the human body. Should Buyer purchase or use ON Semiconductor products for any such unintended or unauthorized application, Buyer shall indemnify and hold ON Semiconductor and its officers, employees, subsidiaries, affiliates, and distributors harmless against all claims, costs, damages, and expenses, and reasonable attorney fees arising out of, directly or indirectly, any claim of personal injury or death associated with such unintended or unauthorized use, even if such claim alleges that ON Semiconductor was negligent regarding the design or manufacture of the part. ON Semiconductor is an Equal Opportunity/Affirmative Action Employer. This literature is subject to all applicable copyright laws and is not for resale in any manner.

FR014H5JZ (14mΩ, -30V) High-Side Reverse Bias / Reverse Polarity Protector With Integrated Over Voltage Transient Suppression

Features

- Up to -30V Reverse-Bias Protection
- Nano Seconds of Reverse-Bias Blocking Response Time
- +32V 24-Hour “Withstand” Rating
- 14mΩ Typical Series Resistance at 5V
- Integrated TVS Over Voltage Suppression
- MLP 3.3x3.3 Package Size
- RoHs Compliant
- USB Tested and Compatible

Applications

- USB 1.0, 2.0 and 3.0 Devices
- USB Charging
- Mobile Devices
- Mobile Medical
- POS Systems
- Toys
- Any DC Barrel Jack Powered Device
- Any DC Devices subject to Negative Hot Plug or Inductive Transients
- Automotive Peripherals

Description

Reverse bias is an increasingly common fault event that may be generated by user error, improperly installed batteries, automotive environments, erroneous connections to third-party chargers, negative “hot plug” transients, inductive transients, and readily available negatively biased rouge USB chargers.

Fairchild circuit protection is proud to offer a new type of reverse bias protection devices. The FR devices are low resistance, series switches that, in the event of a reverse bias condition, shut off power and block the negative voltage to help protect downstream circuits.

The FR devices are optimized for the application to offer best in class reverse bias protection and voltage capabilities while minimizing size, series voltage drop, and normal operating power consumption.

In the event of a reverse bias application, FR014H5JZ devices effectively provide a full voltage block and can easily protect -0.3V rated silicon.

From a power perspective, in normal bias, a 14mΩ FR device in a 1.5A application will generate only 21mV of voltage drop or 32mW of power loss. In reverse bias, FR devices dissipate less than 20μW in a 16V reverse bias event. This type of performance is not possible with a diode solution.

Benefits extend beyond the device. Due to low power dissipation, not only is the device small, but heat sinking requirements and cost can be minimized as well.

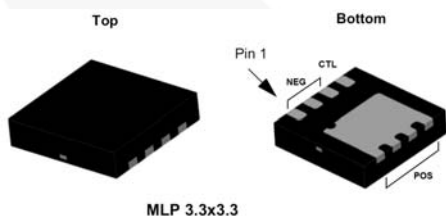

Ordering Information

Part Number	Top Mark	Package	Packing Method
FR014H5JZ	14H	8-Lead, Molded Leadless Package (MLP), Dual, 3.3mm Square	3000 on Tape & Reel; 13-inch Reel, 12mm Tape

Diagrams

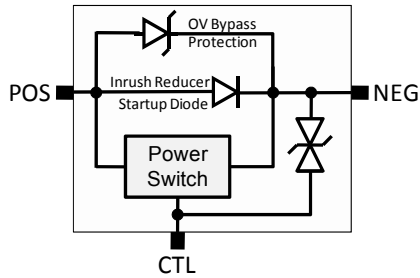

Figure 1. Block Diagram

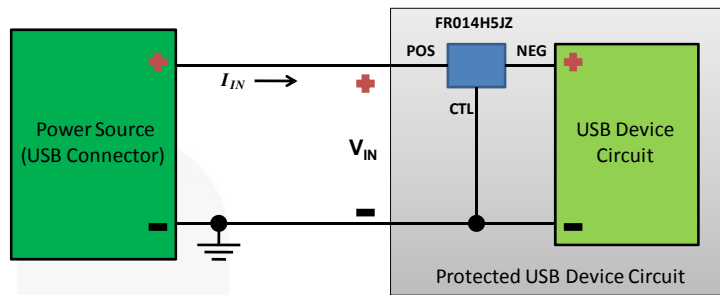

Figure 2. Typical Schematic

Pin Configuration

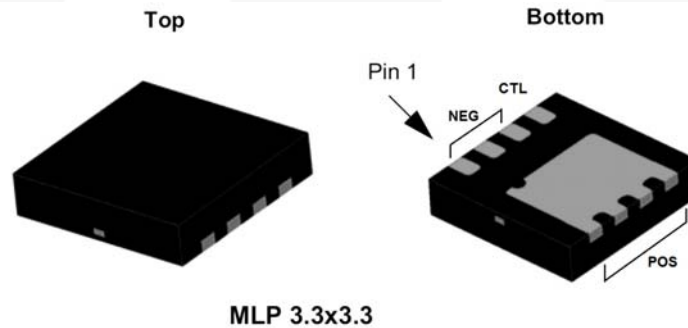

Figure 3. Pin Assignments

Pin Definitions

Name	Pin	Description
POS	5, 6, 7, 8	The positive terminal of the power source. Current flows into this pin during normal operation.
CTL	4	The control pin of the device. A negative voltage to the POS pin turns the switch on and a positive voltage turns the switch to a high-impedance state.
NEG	1, 2, 3	The positive terminal of the load circuit to be protected. Current flows out of this pin during normal operation.

Absolute Maximum Ratings

Values are at $T_A=25^\circ\text{C}$ unless otherwise noted.

Symbol	Parameter		Value	Unit		
$V+_{MAX_OP}$	Steady-State Normal Operating Voltage between POS and CTL Pins ($V_{IN} = V+_{MAX_OP}$, $I_{IN} = 1.5\text{A}$, Switch On)		+25	V		
$V+_{24}$	24-Hour Normal Operating Voltage Withstand Capability between POS and CTL Pins ($V_{IN} = V+_{24}$, $I_{IN} = 1.5\text{A}$, Switch On) ⁽¹⁾		+32			
$V-_{MAX_OP}$	Steady-State Reverse Bias Standoff Voltage between POS and CTL Pins ($V_{IN} = V-_{MAX_OP}$)		-30			
I_{IN}	Input Current	$V_{IN} = 5\text{V}$, Continuous ⁽²⁾ (see Figure 4)	8	A		
T_J	Operating Junction Temperature		150	$^\circ\text{C}$		
P_D	Power Dissipation	$T_C = 25^\circ\text{C}$	36	W		
		$T_A = 25^\circ\text{C}$ ⁽²⁾ (see Figure 4)	2.3			
I_{DIODE_CONT}	Steady-State Diode Continuous Forward Current from POS to NEG ⁽²⁾ (see Figure 4)		2	A		
I_{DIODE_PULSE}	Pulsed Diode Forward Current from POS to NEG (300 μs Pulse) ⁽²⁾ (see Figure 5)		450			
ESD	Electrostatic Discharge Capability	Human Body Model, JESD22-A114		8	kV	
		Charged Device Model, JESD22-C101		2		
		System Model, IEC61000-4-2	NEG is shorted to CTL and connected to GND	Contact		8
				Air		15
			No external connection between NEG and CTL	Contact		3
				Air		4

Notes:

- The V_{+24} rating is NOT a survival guarantee. It is a statistically calculated survivability reference point taken on qualification devices, where the predicted failure rate is less than 0.01% at the specified voltage for 24 hours. It is intended to indicate the device's ability to withstand transient events that exceed the recommended operating voltage rating. Specification is based on qualification devices tested using accelerated destructive testing at higher voltages, as well as production pulse testing at the V_{+24} level. Production device field life results may vary. Results are also subject to variation based on implementation, environmental considerations, and circuit dynamics. Systems should never be designed with the intent to normally operate at V_{+24} levels. Contact Fairchild Semiconductor for additional information.
- The device power dissipation and thermal resistance (R_θ) are characterized with device mounted on the following FR4 printed circuit boards, as shown in Figure 4 and Figure 5

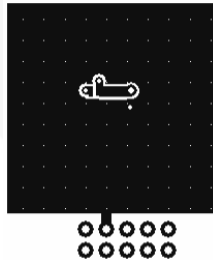

Figure 4. 1 Square Inch of 2-ounce copper



Figure 5. Minimum Pads of 2-ounce Copper

Thermal Characteristics

Symbol	Parameter	Value	Unit
$R_{\theta JC}$	Thermal Resistance, Junction to Case	3.4	$^\circ\text{C/W}$
$R_{\theta JA}$	Thermal Resistance, Junction to Ambient ⁽²⁾ (see Figure 4)	50	

Electrical Characteristics

Values are at $T_A = 25^\circ\text{C}$ unless otherwise noted.

Symbol	Parameter	Conditions	Min.	Typ.	Max.	Unit
Positive Bias Characteristics						
R_{ON}	Device Resistance, Switch On	$V_{IN} = +4\text{V}, I_{IN} = 1.5\text{A}$		18	23	m Ω
		$V_{IN} = +5\text{V}, I_{IN} = 1.5\text{A}$		14	19	
		$V_{IN} = +5\text{V}, I_{IN} = 1.5\text{A}, T_J = 125^\circ\text{C}$		20		
		$V_{IN} = +12\text{V}, I_{IN} = 1.5\text{A}$		11	14	
V_{ON}	Input Voltage, V_{IN} , at which Voltage at POS, V_{POS} , Reaches a Certain Level at Given Current	$I_{IN} = 100\text{mA}, V_{POS} - V_{NEG} = 50\text{mV}, V_{CTL} = 0\text{V}$	2.0	2.4	3.0	V
$\Delta V_{ON} / \Delta T_J$	Temperature Coefficient of V_{ON}			-3.52		mV/ $^\circ\text{C}$
V_F	Diode Forward Voltage	$V_{CTL} = V_{NEG}, I_{DIODE} = 0.1\text{A}, \text{Pulse width} < 300\mu\text{s}$	0.57	0.63	0.70	V
I_{BIAS}	Bias Current Flowing into POS Pin during Normal Bias Operation	$V_{POS} = 5\text{V}, V_{CTL} = 0\text{V}, \text{No Load}$		30		nA
Negative Bias Characteristics						
V_{-MAX_OP}	Reverse Bias Breakdown Voltage				-30	V
$\Delta V_{-MAX_OP} / \Delta T_J$	Reverse Bias Breakdown Voltage Temperature Coefficient	$I_{IN} = -250\mu\text{A}, V_{CTL} = V_{NEG} = 0\text{V}$		22.5		mV/ $^\circ\text{C}$
I_{-}	Leakage Current from NEG to POS in Reverse-Bias Condition	$V_{POS} = -20\text{V}, V_{CTL} = V_{NEG} = 0\text{V}$		1		μA
t_{RN}	Time to Respond to Negative Bias Condition	$V_{CTL} = 5\text{V}, V_{POS} = 0\text{V}, C_{LOAD} = 10\mu\text{F}, \text{Reverse Bias Startup Inrush Current} = 0.2\text{A}$			50	ns
Integrated TVS Performance						
V_Z	Breakdown Voltage @ I_T	$I_T = 1\text{mA}, 300\mu\text{s Pulse}$	28.5	30	31.2	V
I_R	Leakage Current from NEG to CTL	$V_{NEG} = +25\text{V}, V_{CTL} = 0\text{V}$		1.5	10	μA
		$V_{NEG} = -25\text{V}, V_{CTL} = 0\text{V}$		-1.5	-10	
I_{PPM}	Max Pulse Current from NEG to CTL	IEC61000-4-5 8x20 μs pulse	$V_{NEG} > V_{CTL}$		0.8	A
			$V_{NEG} < V_{CTL}$		-0.9	
V_C	Clamping Voltage form NEG to CTL at I_{PPM}	IEC61000-4-5 8x20 μs pulse	$V_{NEG} > V_{CTL}$		34	V
			$V_{NEG} < V_{CTL}$		-34	
Dynamic Characteristics						
C_i	Input Capacitance between POS and CTL			2440		pF
C_s	Switch Capacitance between POS and NEG	$V_{IN} = -5\text{V}, V_{CTL} = V_{NEG} = 0\text{V}, f = 1\text{MHz}$		564		
C_o	Output Capacitance between NEG and CTL			2526		
R_C	Control Internal Resistance			3.6		Ω

Typical Characteristics

$T_J = 25^\circ\text{C}$ unless otherwise specified.

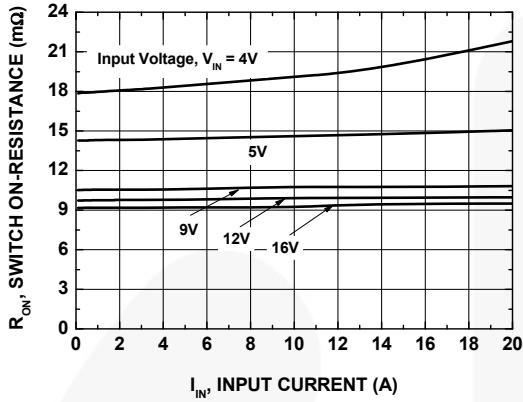

Figure 6. Switch On Resistance vs. Switch Current

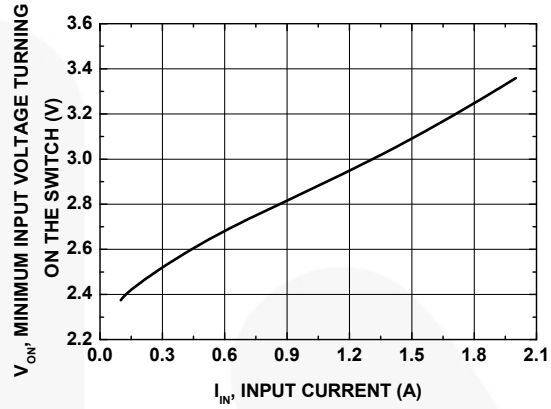

Figure 7. Minimum Input Voltage to Turn On Switch vs. Current at 50mV Switch Voltage Drop

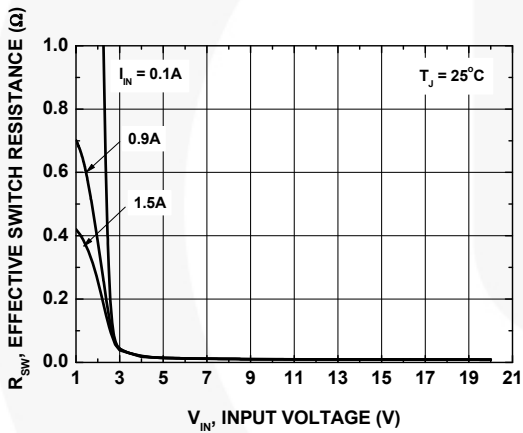

Figure 8. Effective Switch Resistance R_{SW} vs. Input Voltage V_{IN}

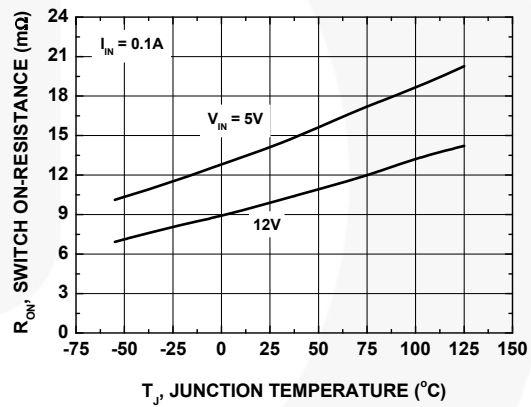

Figure 9. Switch On Resistance vs. Junction Temperature at 0.1A

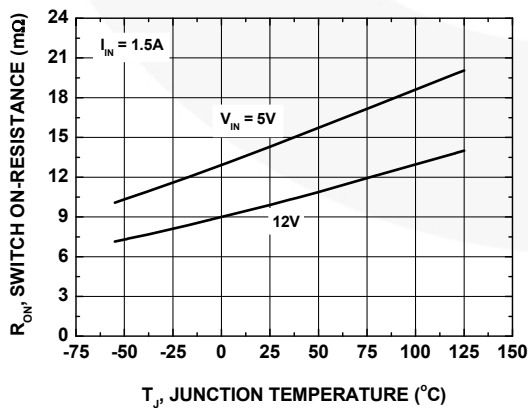

Figure 10. Switch On Resistance vs. Junction Temperature at 1.5A

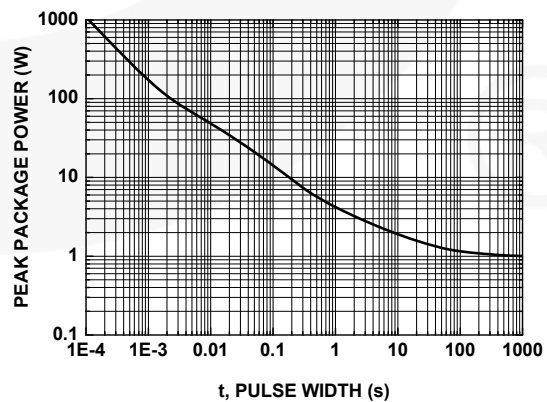

Figure 11. Single-Pulse Maximum Power vs. Time

Typical Characteristics

$T_J = 25^\circ\text{C}$ unless otherwise specified.

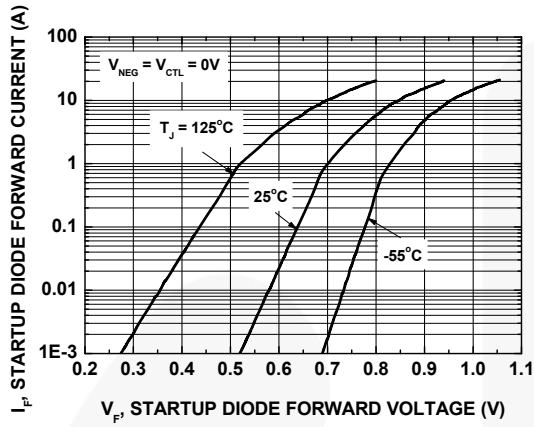

Figure 12. Startup Diode Current vs. Forward Voltage

Application Test Configurations

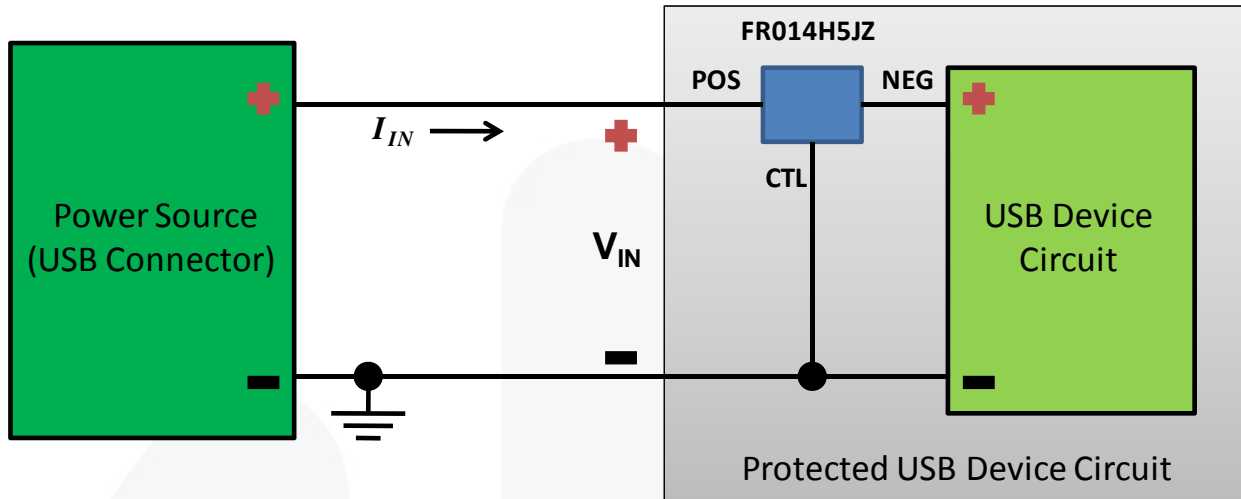

Figure 13. Typical Application Circuit for USB Applications

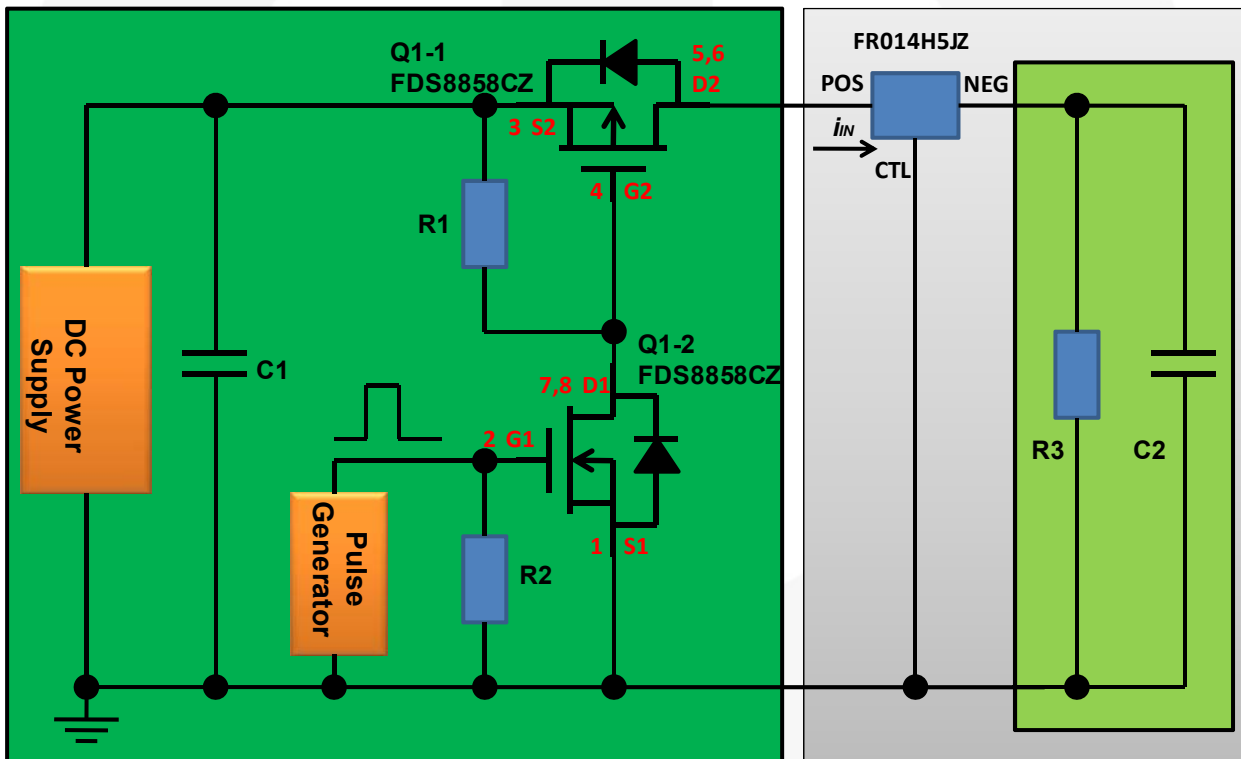

Figure 14. Startup Test Circuit – Normal Bias with FR014H5JZ

Application Test Configurations (Continued)

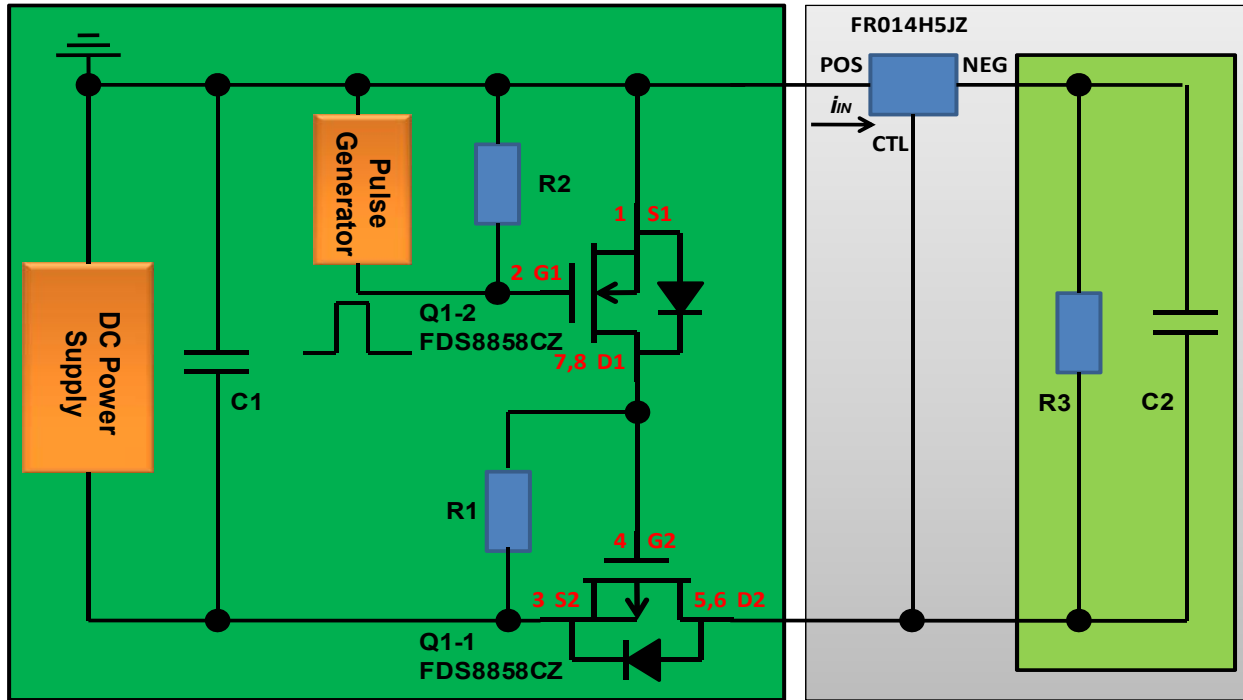

Figure 15. Startup Test Circuit – Reverse Bias with FR014H5JZ

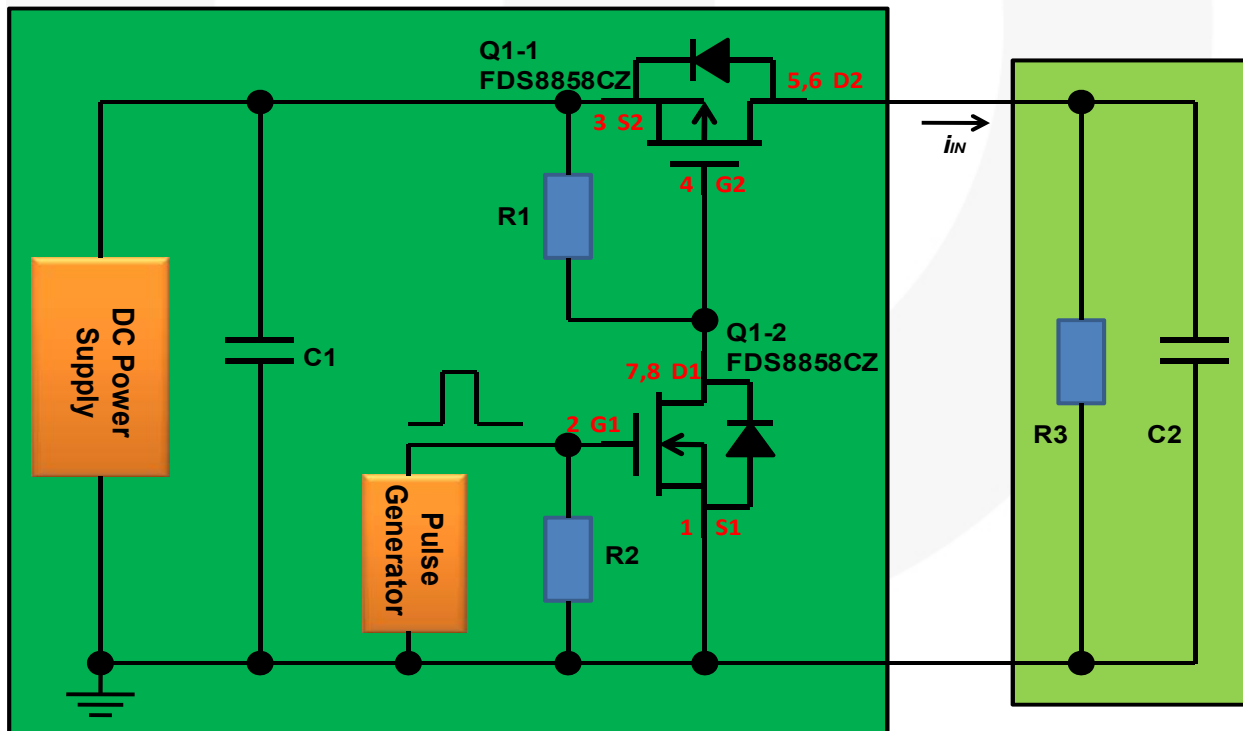

Figure 16. Startup Test Circuit – without FR014H5JZ

Typical Application Waveforms

Typical USB3.0 conditions.

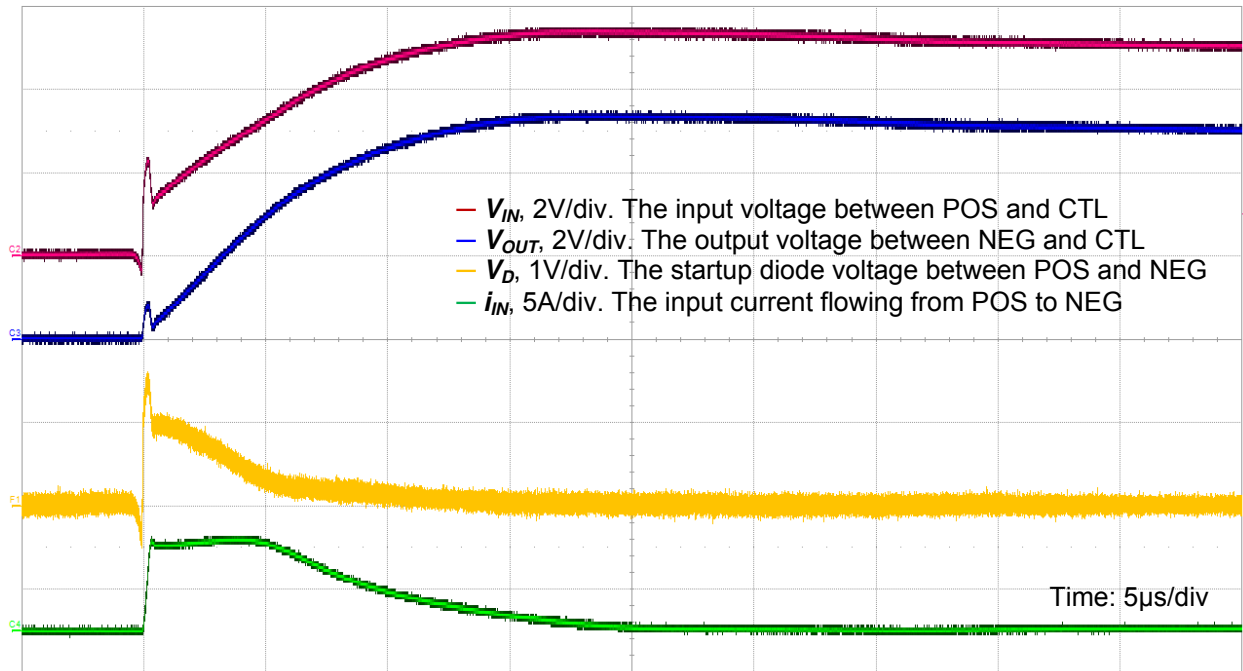

Figure 17. Normal Bias Startup Waveform, DC Power Source=5V, $C_1=100\mu\text{F}$, $C_2=10\mu\text{F}$, $R_1=R_2=10\text{k}\Omega$, $R_3=27\Omega$

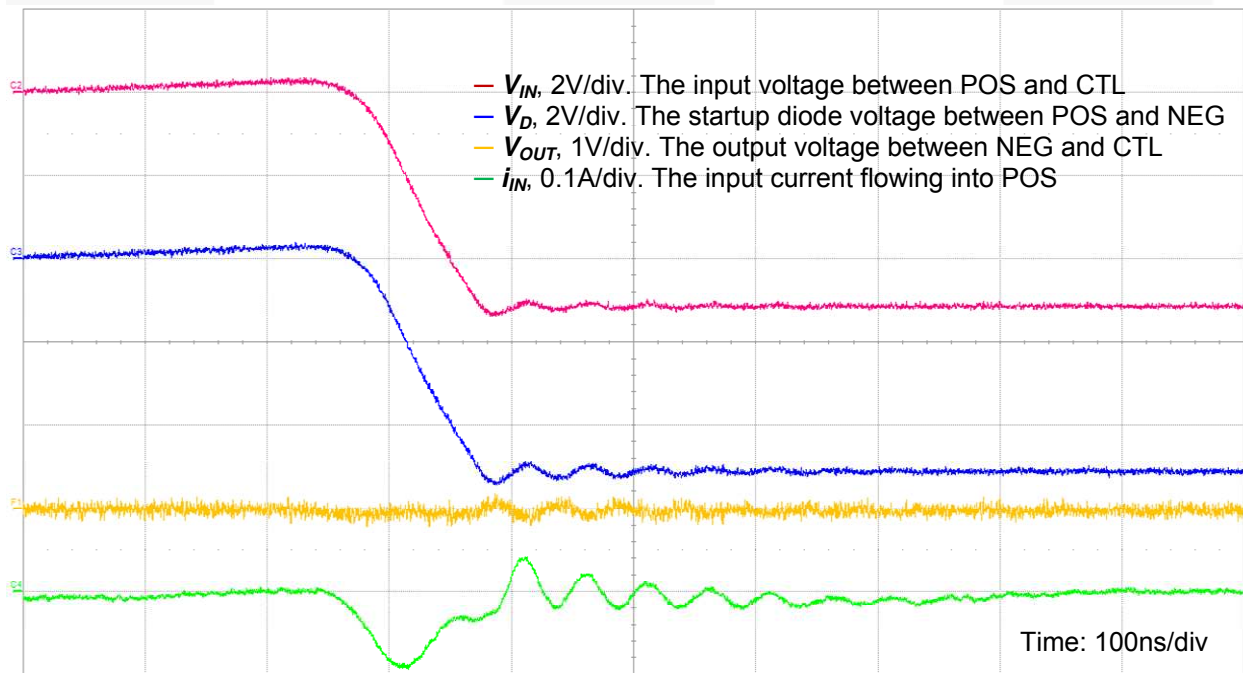

Figure 18. Reverse Bias Startup Waveform, DC Power Source=5V, $C_1=100\mu\text{F}$, $C_2=10\mu\text{F}$, $R_1=R_2=10\text{k}\Omega$, $R_3=27\Omega$

Typical Application Waveforms (Continued)

Typical USB3.0 conditions.

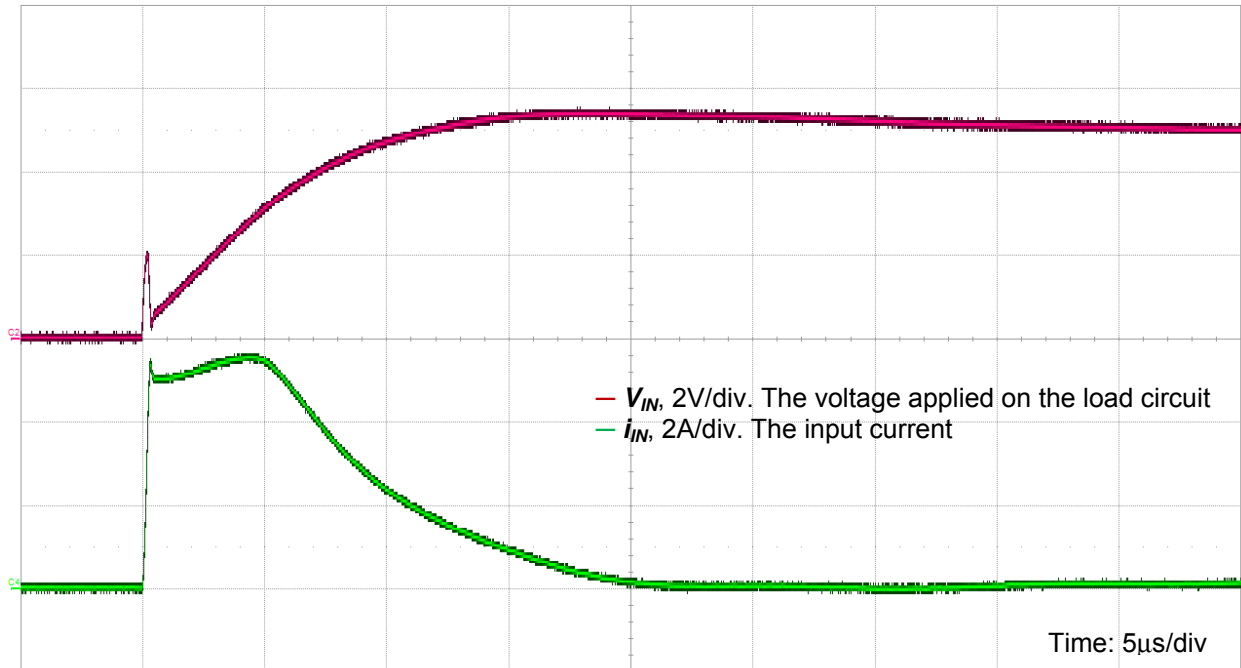

Figure 19. Startup Waveform without FR014H5JZ, DC Power Source=5V, $C_1=100\mu\text{F}$, $C_2=10\mu\text{F}$, $R_1=R_2=10\text{k}\Omega$, $R_3=27\Omega$

Application Information

Figure 17 shows the voltage and current waveforms when a virtual USB3.0 device is connected to a 5V source. A USB application allows a maximum source output capacitance of $C_1 = 120\mu\text{F}$ and a maximum device-side input capacitance of $C_2 = 10\mu\text{F}$ plus a maximum load (minimum resistance) of $R_3 = 27\Omega$. $C_1 = 100\mu\text{F}$, $C_2 = 10\mu\text{F}$ and $R_3 = 27\Omega$ were used for testing.

When the DC power source is connected to the circuit (refer to Figure 13), the built-in startup diode initially conducts the current such that the USB device powers up. Due to the initial diode voltage drop, the FR014H5JZ effectively reduces the peak inrush current of a hot plug event. Under these test conditions, the input inrush current reaches about 6A peak. While the current flows, the input voltage increases. The speed of this input voltage increase depends on the time constant formed by the load resistance R_3 and load capacitance C_2 . The larger the time constant, the slower the input voltage increase. As the input voltage approaches a level equal to the protector's turn-on voltage, V_{ON} , the protector turns on and operates in Low-Resistance Mode as defined by V_{IN} and operating current I_{IN} .

In the event of a negative transient, or when the DC power source is reversely connected to the circuit, the device blocks the flow of current and holds off the voltage, thereby protecting the USB device. Figure 18 shows the voltage and current waveforms when a virtual

USB3.0 device is reversely biased; the output voltage is near 0 and response time is less than 50ns.

Figure 19 shows the voltage and current waveforms when no reverse bias protection is implemented. In Figure 17, while the reverse bias protector is present, the input voltage, V_{IN} , and the output voltage, V_O , are separated and look different. When this reverse bias protector is removed, V_{IN} and V_O merge, as shown in Figure 19 as V_{IN} . This V_{IN} is also the voltage applied to the load circuit. It can be seen that, with reverse bias protection, the voltage applied to the load and the current flowing into the load look very much the same as without reverse bias protection.

Benefits of Reverse Bias Protection

The most important benefit is to prevent accidentally reverse-biased voltage from damaging the USB load. Another benefit is that the peak startup inrush current can be reduced. How fast the input voltage rises, the input/output capacitance, the input voltage, and how heavy the load is determine how much the inrush current can be reduced. In a 5V USB application, for example, the inrush current can be 5% - 20% less with different input voltage rising rate and other factors. This can offer a system designer the option of increasing C_2 while keeping "effective" USB device capacitance down.

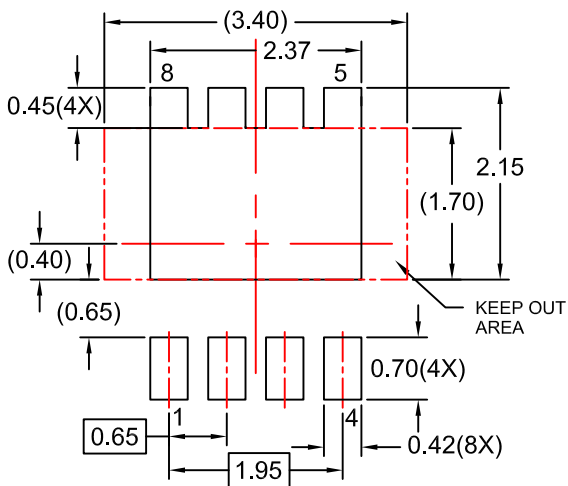
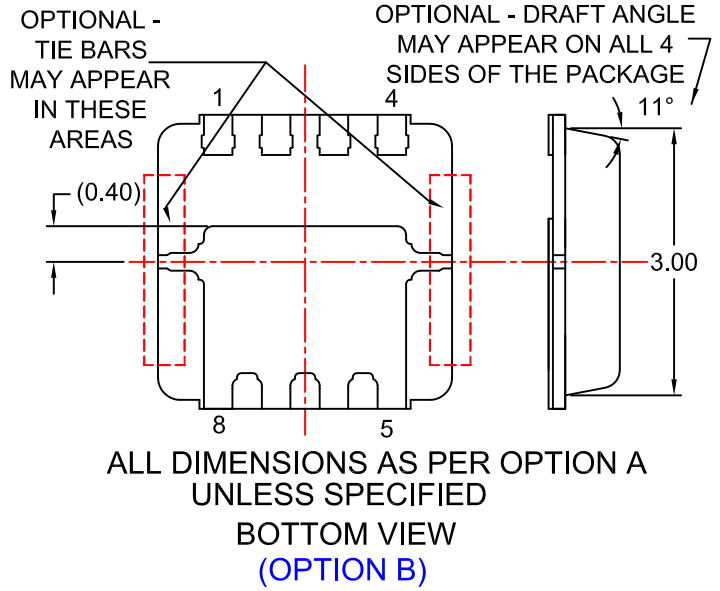
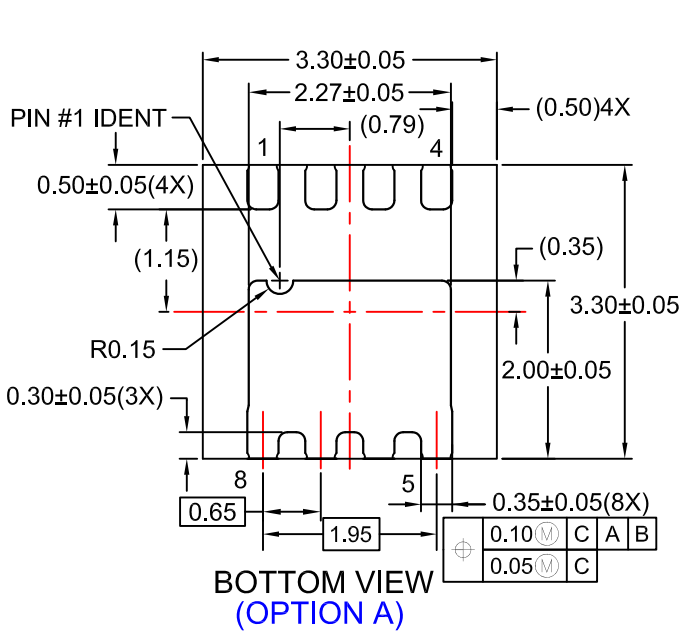
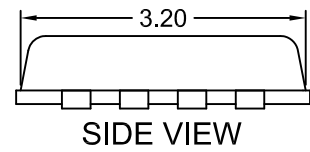
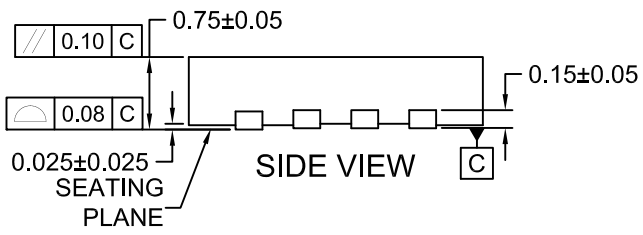
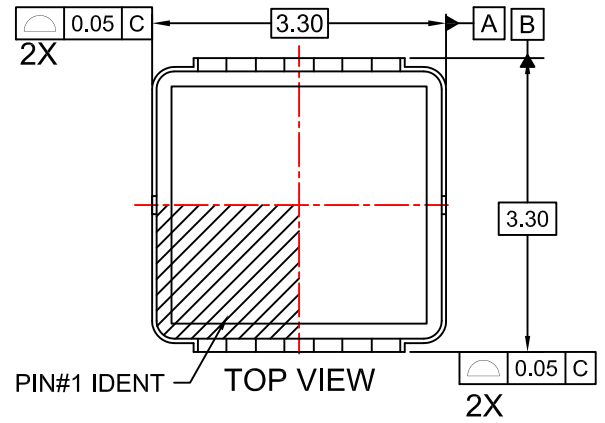
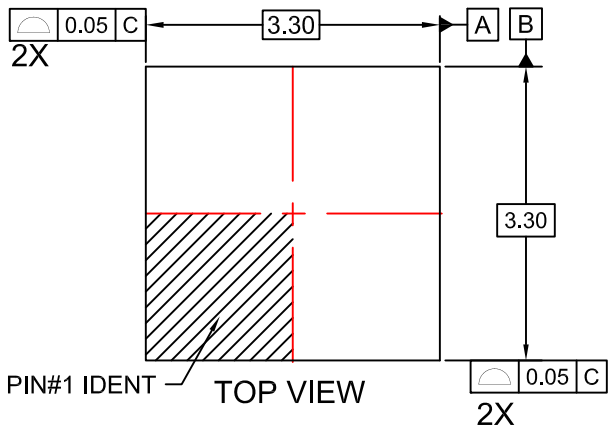

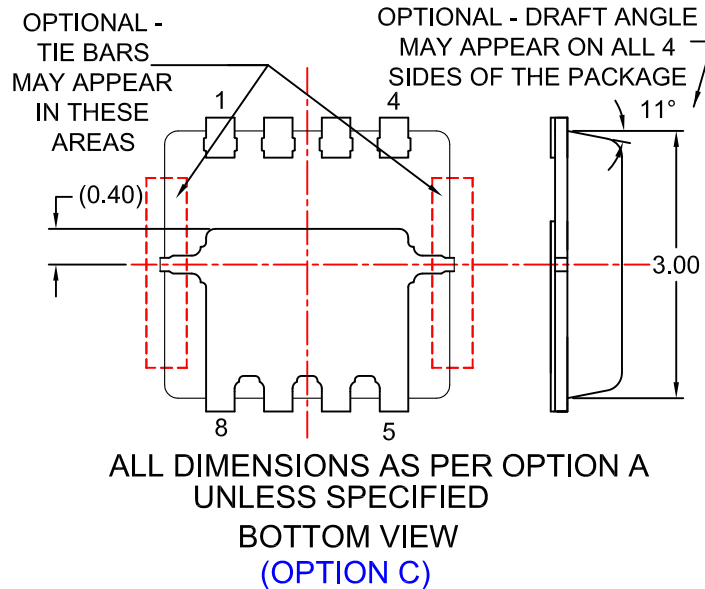
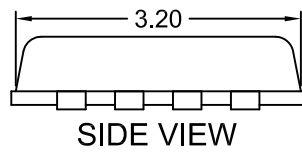
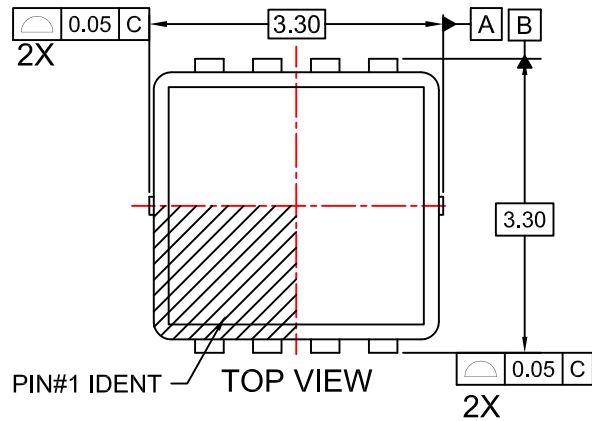

NOTES:

- A. PACKAGE DOES NOT FULLY CONFORM TO JEDEC REGISTRATION MO-240.
- B. DIMENSIONS ARE IN MILLIMETERS.
- C. DIMENSIONS AND TOLERANCES PER ASME Y14.5M, 2009.
- D. LAND PATTERN RECOMMENDATION IS EXISTING INDUSTRY LAND PATTERN
- E. DIMENSIONS DO NOT INCLUDE BURRS OR MOLD FLASH. BURRS OR MOLD FLASH SHALL NOT EXCEED 0.10MM.
- F. DRAWING FILENAME: MKT-MLP08Wrev3.
- G. OPTION A - SAWN MLP, OPTIONS B & C - PUNCH MLP.



ON Semiconductor and  are trademarks of Semiconductor Components Industries, LLC dba ON Semiconductor or its subsidiaries in the United States and/or other countries. ON Semiconductor owns the rights to a number of patents, trademarks, copyrights, trade secrets, and other intellectual property. A listing of ON Semiconductor's product/patent coverage may be accessed at www.onsemi.com/site/pdf/Patent-Marking.pdf. ON Semiconductor reserves the right to make changes without further notice to any products herein. ON Semiconductor makes no warranty, representation or guarantee regarding the suitability of its products for any particular purpose, nor does ON Semiconductor assume any liability arising out of the application or use of any product or circuit, and specifically disclaims any and all liability, including without limitation special, consequential or incidental damages. Buyer is responsible for its products and applications using ON Semiconductor products, including compliance with all laws, regulations and safety requirements or standards, regardless of any support or applications information provided by ON Semiconductor. "Typical" parameters which may be provided in ON Semiconductor data sheets and/or specifications can and do vary in different applications and actual performance may vary over time. All operating parameters, including "Typicals" must be validated for each customer application by customer's technical experts. ON Semiconductor does not convey any license under its patent rights nor the rights of others. ON Semiconductor products are not designed, intended, or authorized for use as a critical component in life support systems or any FDA Class 3 medical devices or medical devices with a same or similar classification in a foreign jurisdiction or any devices intended for implantation in the human body. Should Buyer purchase or use ON Semiconductor products for any such unintended or unauthorized application, Buyer shall indemnify and hold ON Semiconductor and its officers, employees, subsidiaries, affiliates, and distributors harmless against all claims, costs, damages, and expenses, and reasonable attorney fees arising out of, directly or indirectly, any claim of personal injury or death associated with such unintended or unauthorized use, even if such claim alleges that ON Semiconductor was negligent regarding the design or manufacture of the part. ON Semiconductor is an Equal Opportunity/Affirmative Action Employer. This literature is subject to all applicable copyright laws and is not for resale in any manner.

PUBLICATION ORDERING INFORMATION

LITERATURE FULFILLMENT:

Literature Distribution Center for ON Semiconductor
19521 E. 32nd Pkwy, Aurora, Colorado 80011 USA
Phone: 303-675-2175 or 800-344-3860 Toll Free USA/Canada
Fax: 303-675-2176 or 800-344-3867 Toll Free USA/Canada
Email: orderlit@onsemi.com

N. American Technical Support: 800-282-9855 Toll Free
USA/Canada
Europe, Middle East and Africa Technical Support:
Phone: 421 33 790 2910
Japan Customer Focus Center
Phone: 81-3-5817-1050

ON Semiconductor Website: www.onsemi.com
Order Literature: <http://www.onsemi.com/orderlit>
For additional information, please contact your local
Sales Representative