



Chipsmall Limited consists of a professional team with an average of over 10 year of expertise in the distribution of electronic components. Based in Hongkong, we have already established firm and mutual-benefit business relationships with customers from,Europe,America and south Asia,supplying obsolete and hard-to-find components to meet their specific needs.

With the principle of "Quality Parts,Customers Priority,Honest Operation,and Considerate Service",our business mainly focus on the distribution of electronic components. Line cards we deal with include Microchip,ALPS,ROHM,Xilinx,Pulse,ON,Everlight and Freescale. Main products comprise IC,Modules,Potentiometer,IC Socket,Relay,Connector.Our parts cover such applications as commercial,industrial, and automotives areas.

We are looking forward to setting up business relationship with you and hope to provide you with the best service and solution. Let us make a better world for our industry!



Contact us

Tel: +86-755-8981 8866 Fax: +86-755-8427 6832

Email & Skype: info@chipsmall.com Web: www.chipsmall.com

Address: A1208, Overseas Decoration Building, #122 Zhenhua RD., Futian, Shenzhen, China





For more information,
visit [freescale.com/
sensortoolbox](http://freescale.com/sensortoolbox)

**FRDM-
K22F-
SA9500**

Freescale and the Freescale logo are trademarks of Freescale Semiconductor, Inc., Reg. U.S. Pat. & Tm. Off. All other product or service names are the property of their respective owners.
© 2015 Freescale Semiconductor, Inc.
FRDMK22FSA9500QRC REV 1
920-28990 REV A

FRDM-K22F-SA9500

FRDM-
K22F-
SA9500

Quick Reference Card

3-Axis Sensor Toolbox Demonstration Kit
Freescale FRDM-STBC-SA9500 and FRDM-K22F
demonstration and development kit



Get Started

Download tools and
documentation under
Jump Start Your Design
at [freescale.com/
sensortoolbox](http://freescale.com/sensortoolbox)



FREESCALE FREEDOM PLATFORM

- 1 Verify package contents:
 - FRDM-K22F/FRDM-STBC-SA9500 assembly
 - USB cable
- 2 Download the mbed Windows serial port driver: developer.mbed.org/handbook/Windows-serial-configuration
- 3 Plug one end of a USB cable into the SDA port on the assembly. Plug the other end of the cable into the USB port on the computer.
- 4 Download and install the latest Sensor Toolbox software at: freescale.com/sensortoolbox
- 5 Start the Sensor Toolbox software.

FXLC95000CL motion-sensing platform integrating a 3-axis MEMS accelerometer and a 32-bit MCU
24 LGA (3 mm x 5 mm x 1 mm)

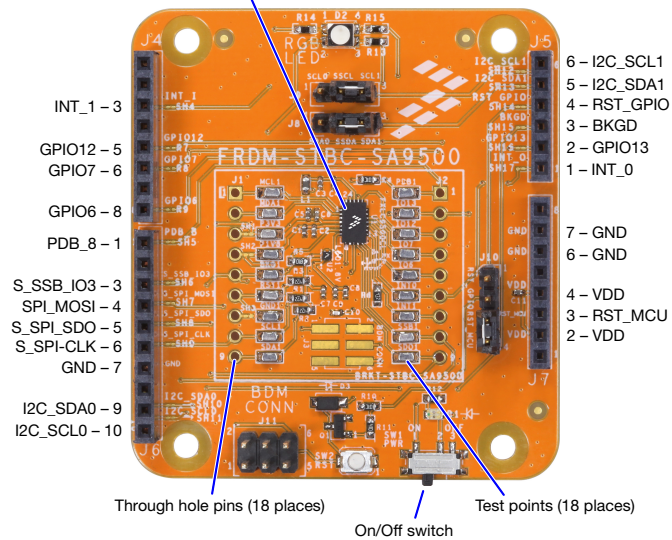

Get to Know the FRDM-K22F-SA9500



Learn more at freescale.com/sensortoolbox