



Chipsmall Limited consists of a professional team with an average of over 10 year of expertise in the distribution of electronic components. Based in Hongkong, we have already established firm and mutual-benefit business relationships with customers from,Europe,America and south Asia,supplying obsolete and hard-to-find components to meet their specific needs.

With the principle of "Quality Parts,Customers Priority,Honest Operation,and Considerate Service",our business mainly focus on the distribution of electronic components. Line cards we deal with include Microchip,ALPS,ROHM,Xilinx,Pulse,ON,Everlight and Freescale. Main products comprise IC,Modules,Potentiometer,IC Socket,Relay,Connector.Our parts cover such applications as commercial,industrial, and automotives areas.

We are looking forward to setting up business relationship with you and hope to provide you with the best service and solution. Let us make a better world for our industry!



Contact us

Tel: +86-755-8981 8866 Fax: +86-755-8427 6832

Email & Skype: info@chipsmall.com Web: www.chipsmall.com

Address: A1208, Overseas Decoration Building, #122 Zhenhua RD., Futian, Shenzhen, China



FRDM-KW24D512 Freedom Development Platform User's Guide

1 Introduction

This manual describes the development platform, FRDM-KW24D512. It has a diverse reference design with all necessary I/O connections to use as a self-contained platform or for connection to an external application.

The MKW24D512 is a 2.4 GHz Industrial, Scientific, and Medical (ISM) single-chip device intended for the IEEE[®] Std. 802.15.4, including Thread, ZigBee[®] Pro stack, ZigBee RF4CE standards, and IPv6/6LoWPAN protocols.

The FRDM-KW24D512 contains the MKW24D512 transceiver that is typically combined with a software stack to implement an IEEE Std. 802.15.4 platform solutions.

1.1 Audience

This document is intended for system designers.

2 Safety Information

2.1 FCC guidelines

This equipment is used by developers for evaluation purposes only and must not be incorporated into any other

Contents

| | |
|--|----|
| 1. Introduction | 1 |
| 1.1.Audience | 1 |
| 2. Safety Information | 1 |
| 2.1.FCC guidelines | 1 |
| 2.2.Regulatory approval for Canada (IC RSS 210) | 2 |
| 2.3.Electrostatic discharge considerations | 3 |
| 2.4.Disposal instructions | 3 |
| 3. FRDM-KW24D512 Overview and Description | 3 |
| 3.1.Introduction | 3 |
| 3.2.Platform features | 4 |
| 3.3.Software and driver considerations | 6 |
| 4. FRDM-KW24D512 Development Platform | 6 |
| 4.1.FRDM-KW24D512 platform overview | 6 |
| 4.2.Functional description | 9 |
| 4.3.Schematic, platform layout, and bill of material | 17 |
| 5. PCB Manufacturing Specifications | 26 |
| 5.1.Single PCB construction | 27 |
| 5.2.Panelization | 28 |
| 5.3.Materials | 28 |
| 5.4.Solder mask | 28 |
| 5.5.Silk screen | 28 |
| 5.6.Electrical PCB testing | 29 |
| 5.7.Packaging | 29 |
| 5.8.Hole specification/tool table | 29 |
| 5.9.File description | 29 |
| 6. Revision History | 29 |



devices or systems. Integrators are responsible for reevaluating the end product (including the transmitter) and obtaining a separate FCC authorization.

FCC approval of this device only covers the original configuration of this device as supplied. Any modifications to this product, including changes shown in this document, may violate the rules of the Federal Communications Commission and Industry Canada and make operation of the product unlawful.

2.1.1 Labeling

FCC labels are physically located on the back of the platform.

2.1.2 Operating conditions

This device complies with part 15 of the FCC rules. Operation is subject to the following two conditions:

- This device may not cause harmful interference.
- This device must accept any interference received, including interference that may cause undesired operation.

2.1.3 Exposure limits

This equipment complies with FCC radiation exposure limits set forth for an uncontrolled environment. The antenna(s) used for this equipment must be installed to provide a separation distance of at least 8 inches (20 cm) from all persons.

2.1.4 Antenna restrictions

An intentional radiator is designed to ensure that no antenna other than that furnished by the responsible party is used with the device. The use of a permanently attached antenna or of an antenna that uses a unique coupling to the intentional radiator is considered sufficient to comply with the provisions of this Section. The manufacturer may design the unit so that a broken antenna can be replaced by the user, but the use of a standard antenna jack or electrical connector is prohibited. This requirement does not apply to carrier current devices or to devices operated under the provisions of Sections 15.211, 15.213, 15.217, 15.219, or 15.221 of the IEEE Std. 802.15.4. In addition, this requirement does not apply to intentional radiators that must be professionally installed, such as perimeter protection systems and some field disturbance sensors, or to other intentional radiators which, in accordance with Section 15.31(d) of the IEEE Std. 802.15.4, must be measured at the installation site. However, the installer is responsible for ensuring that the proper antenna is employed so that the limits in this Part are not exceeded.

2.2 Regulatory approval for Canada (IC RSS 210)

This equipment complies with Industry Canada licence-exempt RSS standard(s). Operation is subject to the following two conditions:

- This platform may not cause interference.
- This platform must accept any interference, including interference that may cause undesired operation of the device.

2.2.1 26 PART 5 – Appendix

Le présent appareil est conforme aux CNR d'Industrie Canada applicables aux appareils radio exempts de licence. L'exploitation est autorisée aux deux conditions suivantes:

1. l'appareil ne doit pas produire de brouillage, et
2. l'utilisateur de l'appareil doit accepter tout brouillage radioélectrique subi, même si le brouillage est susceptible d'en compromettre le fonctionnement.

2.3 Electrostatic discharge considerations

Although damage from electrostatic discharge (ESD) is much less common on these devices than on early CMOS circuits, normal handling precautions should be used to avoid exposure to static discharge. Qualification tests are performed to ensure that these devices can withstand exposure to reasonable levels of static without suffering any permanent damage.

All ESD testing is in conformity with the JESD22 Stress Test Qualification for Commercial Grade Integrated Circuits. During the device qualification, ESD stresses are performed for the human body model (HBM), the machine model (MM), and the charge device model (CDM).

All latch-up tests are in conformity with the JESD78 IC Latch-Up Test.

When operating or handling the development platforms or components, it is strongly recommended to use at least the grounding wrist straps plus any, or all, of the following ESD dissipation methods:

- Flexible fabric, solid fixed size, or disposable ESD wrist straps
- Static control workstations, static control monitors, and table or floor static control systems
- Static control packaging and transportation materials and environmental systems

2.4 Disposal instructions

The NXP development platforms must be disposed of in compliance with current local waste disposal regulations. Appliances disposal should be done by a qualified company.

3 FRDM-KW24D512 Overview and Description

3.1 Introduction

The FRDM-KW24D512 development platform is an evaluation environment based on the NXP MKW24D512 transceiver (MKW24).

The MKW24D512 device incorporates a complete low power IEEE Std. 802.15.4 2.4 GHz radio frequency transceiver and a Kinetis family low-power, mixed-signal ARM[®] Cortex[®]-M4 MCU into a single package.

NXP supplements the MKW24D512 with tools and software that include hardware evaluation and development platforms, software development IDE, and applications, drivers, custom PHY usable with the NXP IEEE Std. 802.15.4 compatible MAC.

The FRDM-KW24D512 development platform contains the MKW24D512 device with 32 MHz reference oscillator crystal, RF circuitry including antenna, 16 Mbit external serial flash, and supporting circuitry in the popular Freedom form factor. The platform is standalone and supports application development with NXP IEEE Std. 802.15.4 protocol stacks and supports full-speed USB 2.0.

3.2 Platform features

3.2.1 FRDM-KW24D512 platform

The FRDM-KW24D512 development platform is part of the Freedom development (FRDM) platform. It has a diverse reference design containing the MKW24D512 device and all necessary I/O connections to use as a self-contained platform or for connection to an external application, and also has the capability to connect with the Freedom development platforms.

Figure 1 shows the FRDM-KW24D512 development platform.

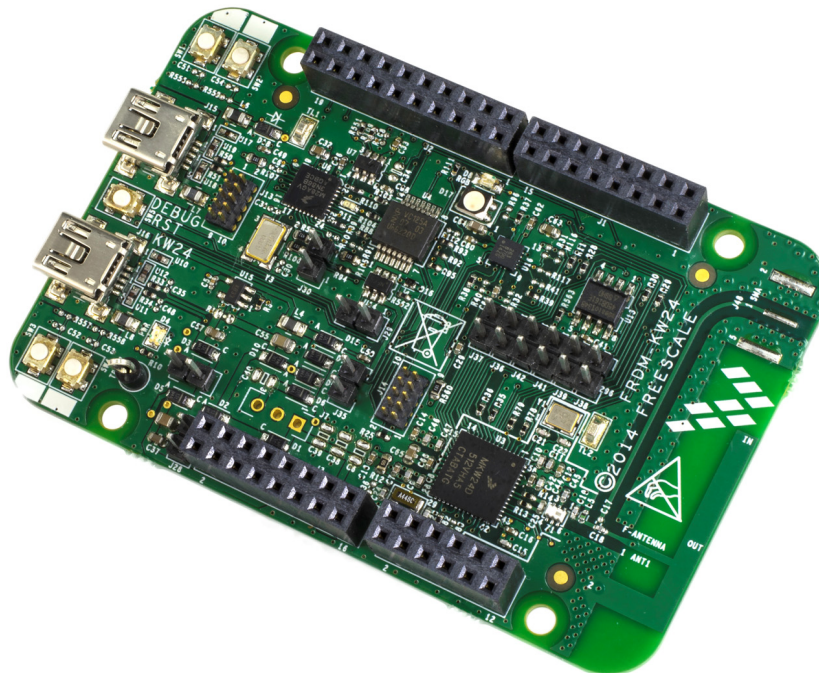

Figure 1. FRDM-KW24D512 development platform

The FRDM-KW24D512 development platform includes the following features:

- The low-power Kinetis MKW24D512 transceiver
- Full IEEE Std. 802.15.4-compliant wireless node; ZigBee and Thread capable
- Reference design area with small footprint, low-cost RF node
 - RF circuitry includes a Balun to convert the differential input/output pin of the MKW24D512 transceiver to single-ended for onboard signal routing
 - Low off-chip component count

- Programmable output power from -35 dBm to +8 dBm at the SMA connector, no trap
- Receiver sensitivity: -102 dBm, typical (@1% PER for 20 byte payload packet)
- Integrated PCB inverted F-type antenna and SMA RF port
- Selectable power sources
- 32 MHz reference oscillator
- 32 kHz clock oscillator
- 2.4 GHz frequency operation (ISM Band)
- External serial flash for over-the-air programming (OTAP) support
- Integrated open-standard serial and debug interface (OpenSDA)
- Cortex 10-pin (0.05 inches) SWD debug port for target MCU
- Cortex 10-pin (0.05 inches) JTAG port for OpenSDA updates
- 1 RGB LED indicator
- 1 Blue LED indicator
- 4 Push button switches
- FXOS8700 Combo Sensor

Figure 2 shows the main platform features and I/O headers for the FRDM-KW24D512 platform.

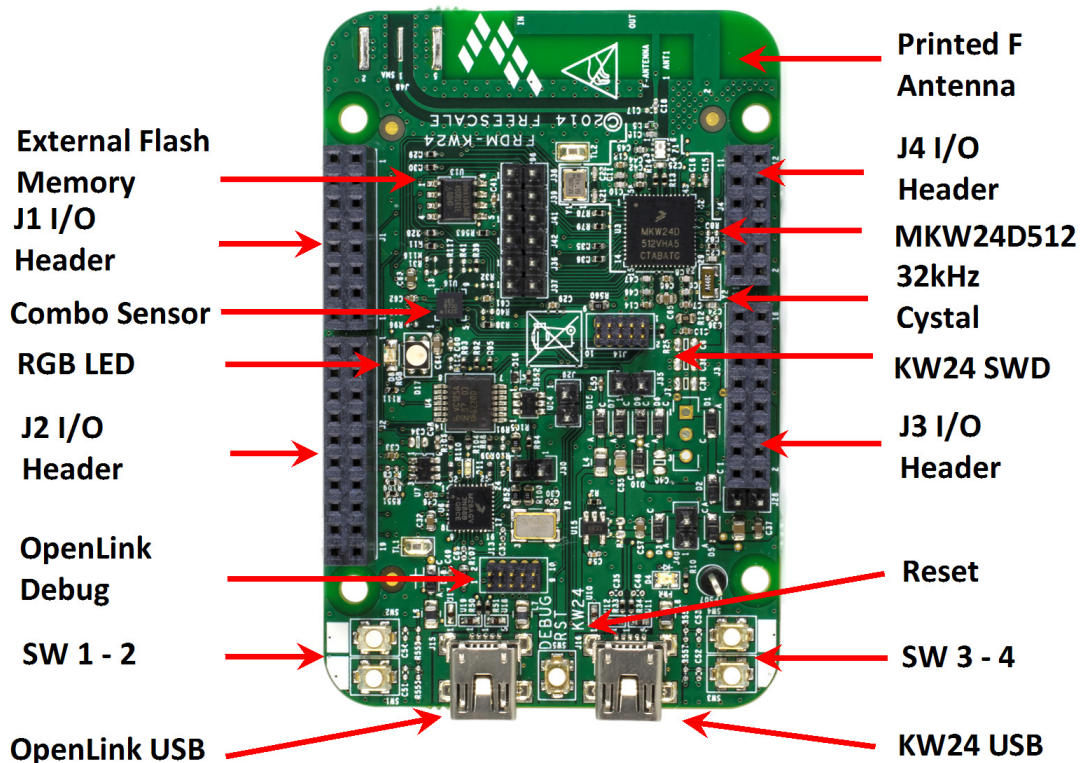

Figure 2. FRDM-KW24D512 components and I/O headers

3.3 Software and driver considerations

The FRDM-KW24D512 platform includes an OpenSDAv2.1, a serial and debug adapter circuit that includes an open-source bootloader, and debug interface software. It bridges serial and debug communications between a USB host and an embedded target processor. The hardware circuit is based on the Kinetis K20 family.

For additional information about our 2.4 GHz Kinetis family platforms, see the following:

- Wireless on nxp.com
- Kinetis KW2xD on nxp.com

4 FRDM-KW24D512 Development Platform

4.1 FRDM-KW24D512 platform overview

The FRDM-KW24D512 is an evaluation platform based on the MKW24D512 transceiver. The FRDM-KW24D512 platform provides a platform to evaluate the MKW24D512 transceiver, develop software and applications. The core device is accompanied by a 32 MHz reference oscillator crystal, RF circuitry including antenna, and supporting circuitry.

The FRDM-KW24D512 platform is intended as the core PCB for MKW24D512 transceiver evaluation and application development, and can be used in the following modes:

- Simple standalone evaluation platform
- Daughter card to other development platforms (Freedom development platform)
- Mother card to an application-specific daughter card, such as a shield card

4.1.1 PCB features

The FRDM-KW24D512 platform provides the following features:

- The Freedom development platform form factor
- 4-Layer metal, 0.062 inch thick FR4 platform
- LGA footprint and power supply bypass
- Printed metal F-Antenna and footprint for installing a (user supplied) SMA connector
- 32 MHz reference oscillator crystal
- 32.768 kHz crystal provided for optional timing oscillator
- Standard FRDM card mounting interface
- External serial flash for OTAP support
- Combo sensor, 6-axis sensor with integrated linear accelerometer and magnetometer

4.1.2 Form factor

[Figure 3](#) shows the FRDM-KW24D512 platform's connector and header locations.

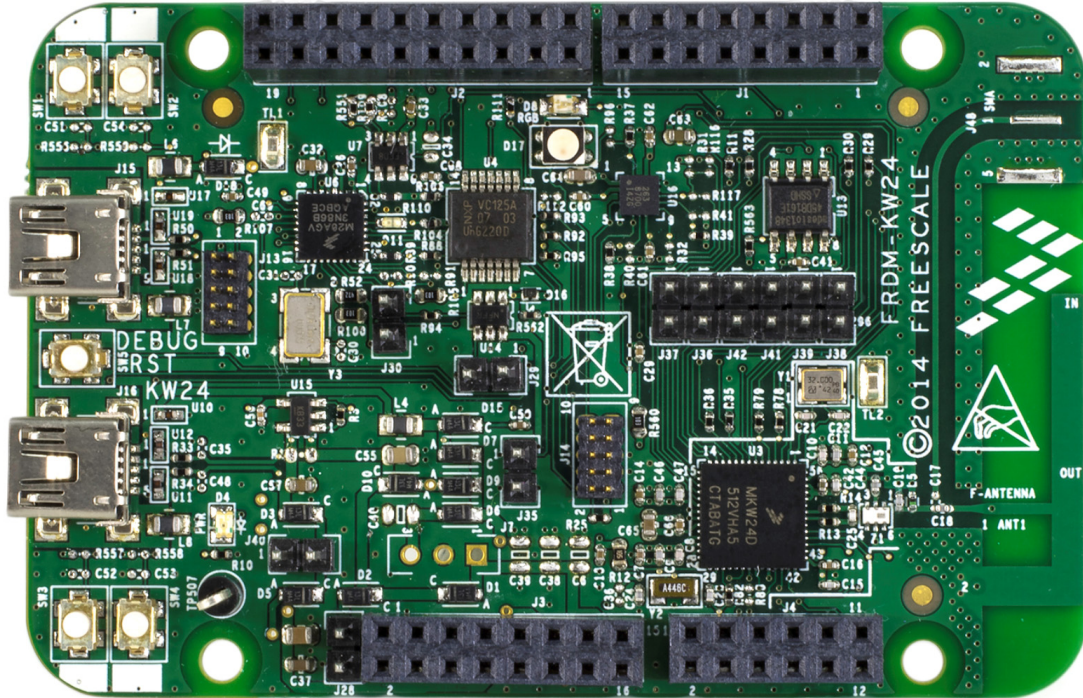

Figure 3. FRDM-KW24D512 platform's connector and header location

Figure 4 shows a footprint of the FRDM-KW24D512 platform with the location of the I/O headers. The parameters of these headers are as follows:

- J1, J2, J3 and J4:
 - Headers have standard 0.1 inch / 2.54 mm pin spacing
 - J1 and J3 are 16-pin
 - J2 is 20-pin
 - J4 is 12-pin
 - Pin headers are mounted on the top side of the FRDM-KW24D512 and are intended to plug into matching receptacles on the Freedom Platform
- J36, J37, J38, J39, J41, and J42:
 - Headers have standard 0.1 in / 2.54 mm pin spacing
 - All headers are 2x2 pin
 - J41 and J42 are adjacent to allow UART0 data direction to be reversed by altering the orientation of the shunt
 - J38 and J39 are adjacent to allow SPI0 data direction to be reversed by altering the orientation of the shunt
 - J36 and J37 are adjacent to allow UART1 data direction to be reversed by altering the orientation of the shunt

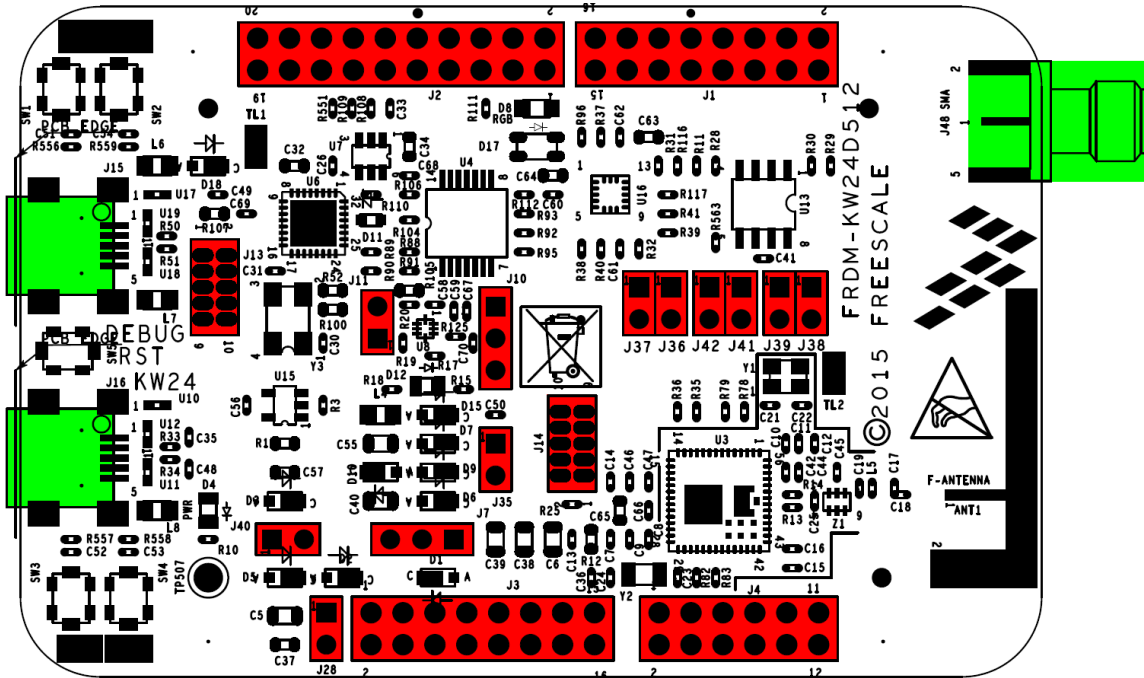

Figure 4. FRDM-KW24D512 platform top side (component side) footprint

4.1.3 Platform level specifications

Table 1. FRDM-KW24D512 platform specifications

| Parameter | Min | Typ | Max | Units | Notes/Conditions |
|----------------------------------|-----|---------------|----------------------------|--------------|--|
| General | | | | | |
| Size (PCB: X, Y) | — | — | 81.2 x 53.3 3.20 x 2.10 | mm inches | — |
| Layer build (PCB) | — | 1.57 0.062 | — | mm inches | 4-Layer |
| Dielectric material (PCB) | — | — | — | — | FR4 |
| Power | | | | | |
| Current consumption | — | — | — | mA | Varies with operational mode, see datasheet. |
| Temperature | | | | | |
| Operating temperature (see note) | -40 | +25 | +70 | °C | Operating temperature is limited to +70 °C due to switches. Basic circuit is good for a maximum temperature of +85 °C. |
| Storage temperature | -30 | +25 | +70 | °C | — |

Table 1. FRDM-KW24D512 platform specifications (continued)

| Parameter | Min | Typ | Max | Units | Notes/Conditions |
|--|------|------|------|-------|---|
| RF | | | | | |
| IEEE 802.15.4 frequency range | 2405 | — | 2480 | MHz | All 16 channels in the 2450 MHz band |
| Operation frequency | 2360 | — | 2480 | MHz | — |
| RF Receiver | | | | | |
| Saturation (maximum input level) | — | +0 | — | dBm | See data sheet |
| Sensitivity for 1% packet error rate (PER) (+25 °C) 802.15.4 | — | -102 | — | dBm | See data sheet |
| RF Transmitter | | | | | |
| RF Power Output | -35 | — | +8 | dBm | Programmable in steps. At the antenna feed with no harmonic trap. ¹ |
| 2nd harmonic | — | ≤40 | ≤35 | dBm | See data sheet |
| 3rd harmonic | — | ≤40 | ≤35 | dBm | See data sheet |
| Regulatory Approval | | | | | |
| FCC | — | — | — | — | Product is approved according to the FCC part 15 standard |
| CE (ETSI) | — | — | — | — | Product is approved according to the EN 300 328 V1.7.1 (2006-10) standard |
| CE (EMC) | — | — | — | — | Product is approved according to the EN 301 489-1 V1.6.1 (2005-09) and EN 301 489-17 V1.2.1 (2002-08) standards |
| Safety | | | | | |
| UL | — | — | — | — | Product is approved according to the IEC 60950-1 and EN 60950-1, First Edition standards |
| Environment | | | | | |
| RoHS | — | — | — | — | Product complies with the EU Directive 2002/95/EC of 27 January 2003 |
| WEEE | — | — | — | — | Product complies with the EU Directive 2002/95/EC of 27 January 2003 |

¹ Harmonic trap adds 1 to 2 dB of loss.

4.2 Functional description

The FRDM-KW24D512 platform is built around the MKW24D512 transceiver in a 63-pin (56-pin usable) LGA package. The MKW24D512 device features a IEEE Std. 802.15.4 radio frequency transceiver and a Kinetis family low-power, mixed-signal ARM Cortex-M4 MCU in a single package. The

FRDM-KW24D512 platform is intended as an evaluation platform and as a building block for application development. The four-layer platform provides the MKW24D512 transceiver with the required RF circuitry, 32 MHz reference oscillator crystal, and power supply bypassing. The layout for this base level functionality can be used as a reference layout for your target platform. Figure 5 shows a simple block diagram.

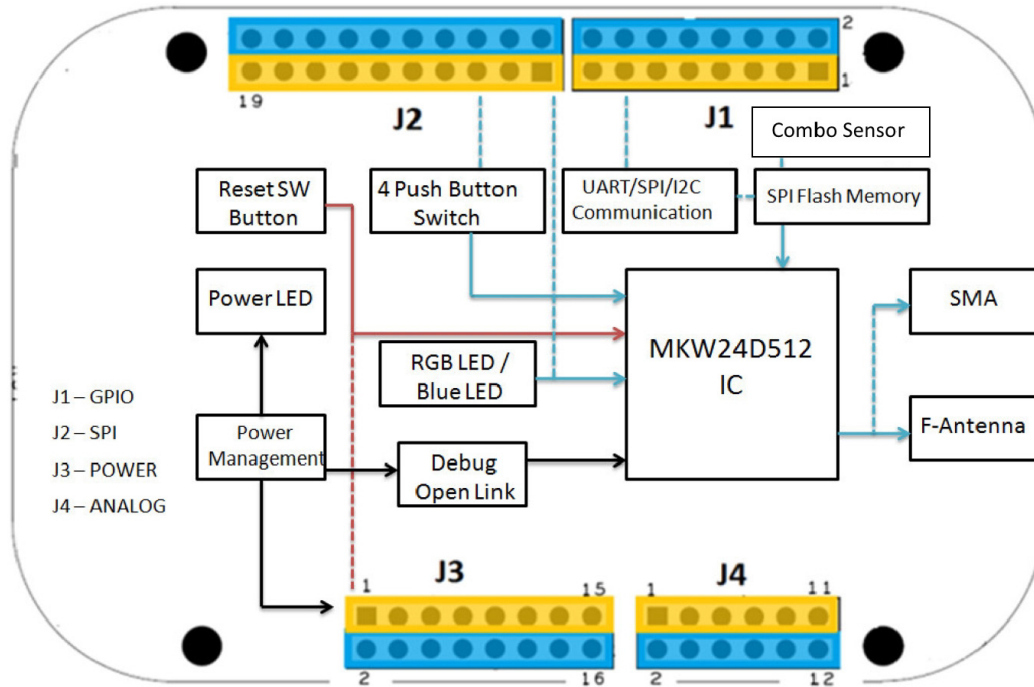

Figure 5. FRDM-KW24D512 block diagram

4.2.1 RF performance and considerations

The FRDM-KW24D512 development platform includes a 1 mW nominal output PA with internal voltage controlled oscillator (VCO), integrated transmit/receive switch, onboard power supply regulation, and full spread-spectrum encoding and decoding. Key specifications for the MKW24D512 transceiver are:

- Programmable output power from -35 dBm to +8 dBm at the SMA, no trap.
- Typical sensitivity is -102 dBm (@1% PER for 20 byte payload packet).
- Frequency range is 2360 to 2480 MHz.
- Differential bidirectional RF input/output port with integrated transmit/receive switch.
- “F” printed metal antenna for a small footprint, low cost design.
- Platform features a low component count RF matching network with off-chip 1:1 Balun.

The layout has provision for out-of-band signal suppression (components L5 and C19) if required.

Figure 6 shows the typical topology for the RF circuitry. A footprint is available to install the RF connector J48 for measurement purposes. When using J48, install C17 and remove C18.

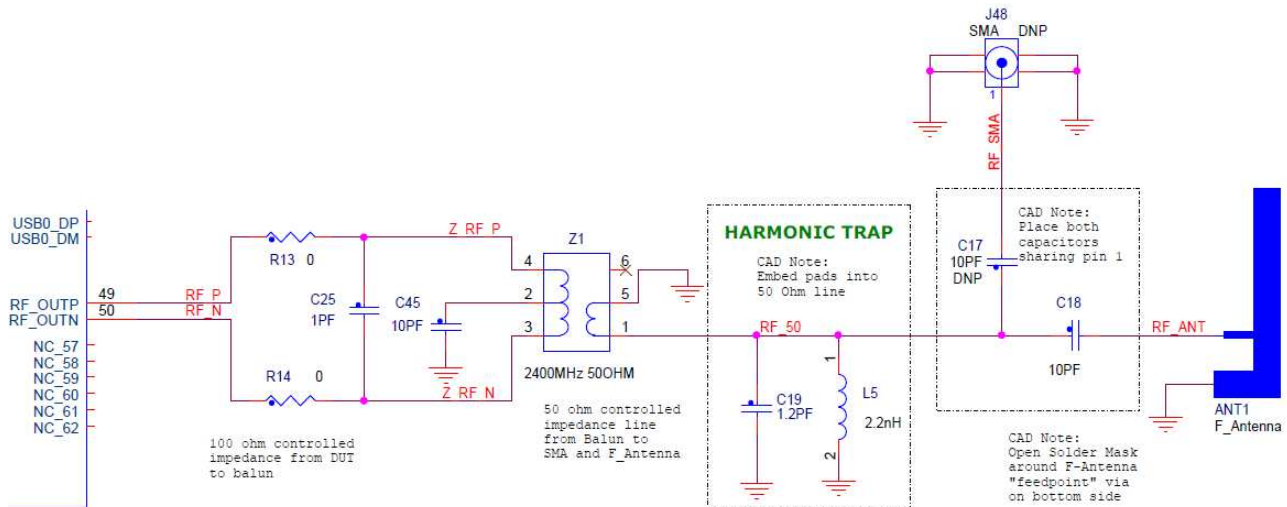
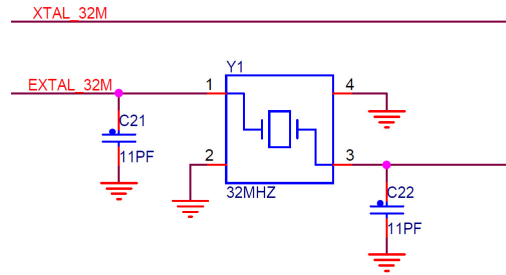

Figure 6. FRDM-KW24D512 RF circuitry

4.2.2 Clocks

The FRDM-KW24D512 provides two clocks:

- 32 MHz Reference Oscillator: Figure 7 shows the external 32 MHz external crystal Y1. This mounted crystal must meet the specifications outlined in the AN3251 application note (AN3251). The IEEE Std. 802.15.4 requires that the frequency be accurate to less than ± 40 ppm.
 - Capacitors C21 and C22 provide the bulk of the crystal load capacitance. At 25°C, it is desired to have the frequency accurate to ± 10 ppm or less to allow for temperature variation.
 - To measure the 32 MHz oscillator frequency, signal CLKOUT (PTA18/CLK_OUT) can optionally be programmed to provide a buffered output clock signal.
- Optional 32.768 kHz Crystal Oscillator: Provision is also made for a secondary 32.768 kHz crystal Y2 (see Figure 8). This oscillator can be used for a low-power accurate time base.
 - The module comes provided with this Y2 crystal and its load capacitors C23 and C24.
 - Load capacitors C23 and C24 provide the entire crystal load capacitance. There is no onboard trim capacitance.
 - The 32 kHz oscillator components are supplied, but not enabled. Zero-ohm resistors R82 and R83 to disable 32 kHz.



XTAL 32MHz

Figure 7. FRDM-KW24D512 platform's 32 MHz reference oscillator circuit

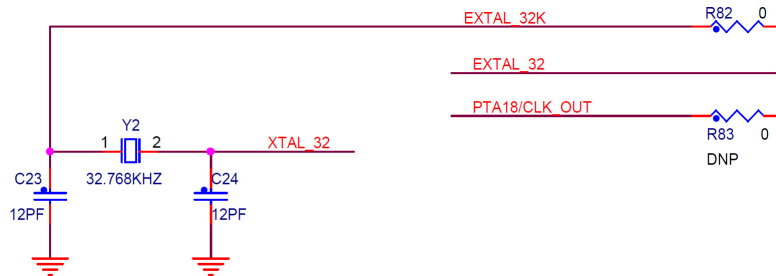

Figure 8. FRDM-KW24D512 platform's 32.768 kHz optional oscillator circuit

4.2.3 Power management

There are several different ways to power and measure current on the FRDM-KW24D512 platform. The FRDM-KW24D512 power management circuit is shown in Figure 9.

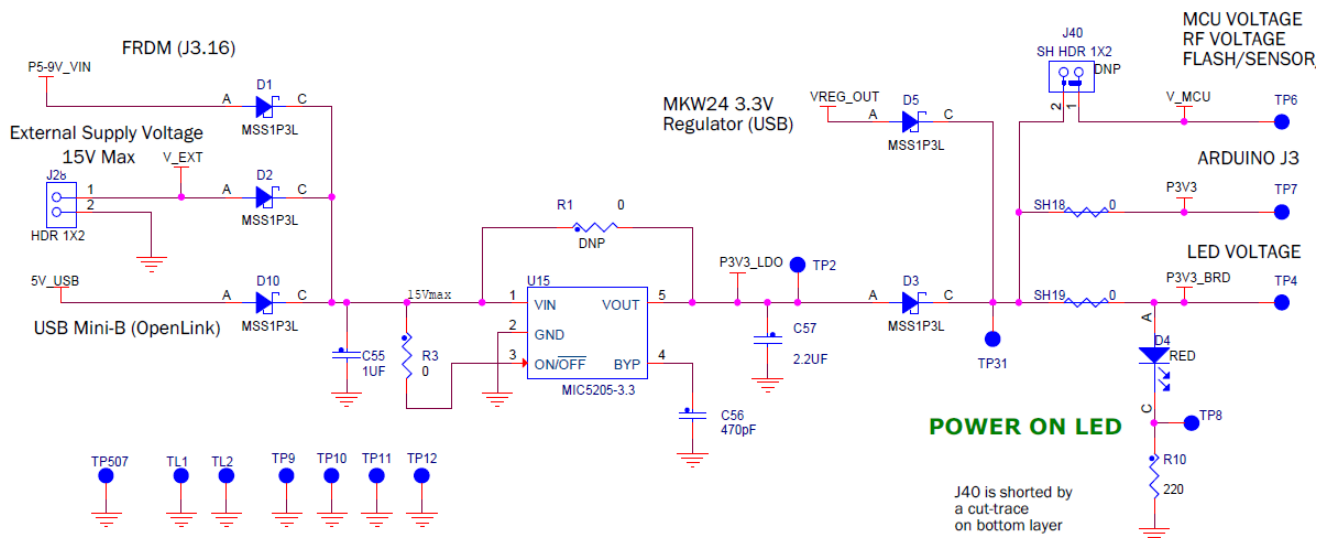

Figure 9. FRDM-KW24D512 platform's power management circuit

The FRDM-KW24D512 platform has the flexibility to be powered in several configurations:

- The platform can be supplied through the micro USB type B connector (J16), which provides P5V_USB to LDO 3V3.
- The platform can be supplied through the development platform's headers, which provide either P3.3V or P5-9V_VIN on header J3 pin 16 to LDO 3V3.
- The platform can be supplied from an external DC supply in the following way:
 - Connect an adaptor capable of supplying more than 3.3 VDC (15 V maximum) to J28 header.

Additionally, J40, a two-pin 1x2 cut-trace header, provides current to the MCU and the transceiver. A red LED marked as LED D4 is available as a power indicator.

Power headers provide the means to supply either the LED, MCU, or peripheral circuits. Current measurements can be made by inserting a current meter in place of a designated jumper. Connection configurations are described in [Table 2](#).

Table 2. Power distribution headers

| Supply designation | Header pins | Description |
|--------------------|-------------|--|
| V_MCU J40 | 1 - 2 | Supply voltage to MCU, transceiver, and peripherals <ul style="list-style-type: none"> • Jumper is shorted by a cut-trace on the bottom layer • Usage: Measure MCU current |
| P3V3 SH18 | — | Supply voltage to header <ul style="list-style-type: none"> • Normally traced |
| P3V3_BRD SH19 | — | Supply voltage to LEDs, switches, and some modules <ul style="list-style-type: none"> • Normally traced |

4.2.4 FRDM-KW24D512 peripheral functions

The FRDM-KW24D512 development platform includes the NXP Freedom platform headers to interface with the general purpose functions and to assist in implementing targeted applications. The FRDM-KW24D512 platform also has alternate port functions routed to those interface headers where off-board FRDM development platform peripherals can be used.

4.2.4.1 Serial flash (SPI interface)

Component U13 is an AT45DB161E 16 Mbit (2 Mbyte) serial flash memory with SPI interface. The memory is useful for over-the-air programming (OTAP) and for storage of non-volatile system data or parameters. [Figure 10](#) shows the memory circuit.

- The memory power supply is P3V3_BRD.
- Place J38 and J39 Jumpers to perform SPI communication with the serial flash module.

- The SPI Write Protect and Reset has discrete pullup resistors

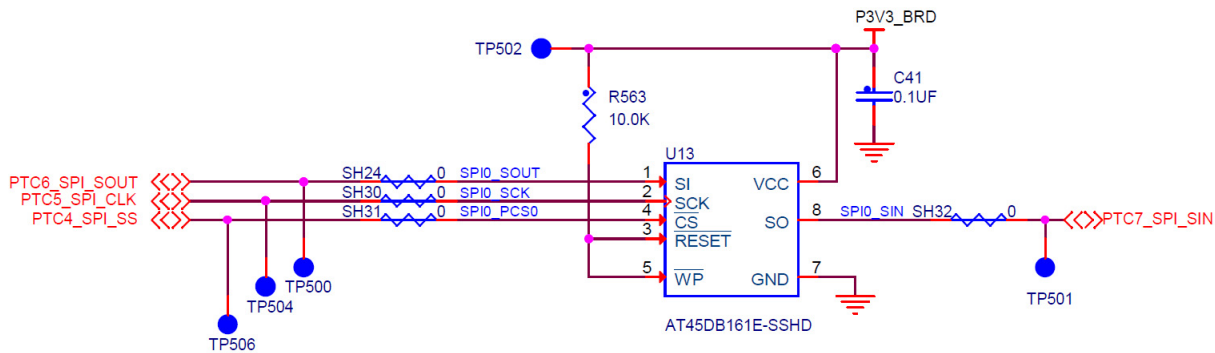

Figure 10. AT45DB161E (2 Mbyte) serial flash memory

4.2.4.2 Combo sensor (I²C interface)

The component U16 is an NXP FXOS8700CQ 6-axis sensor with integrated linear accelerometer and magnetometer, very low-power consumption, and I²C selectable. Figure 11 shows the sensor circuit.

- The sensor power supply is P3V3_BRD.
- Discrete pullup resistors for the I²C port are provided.
- One interrupt signal.

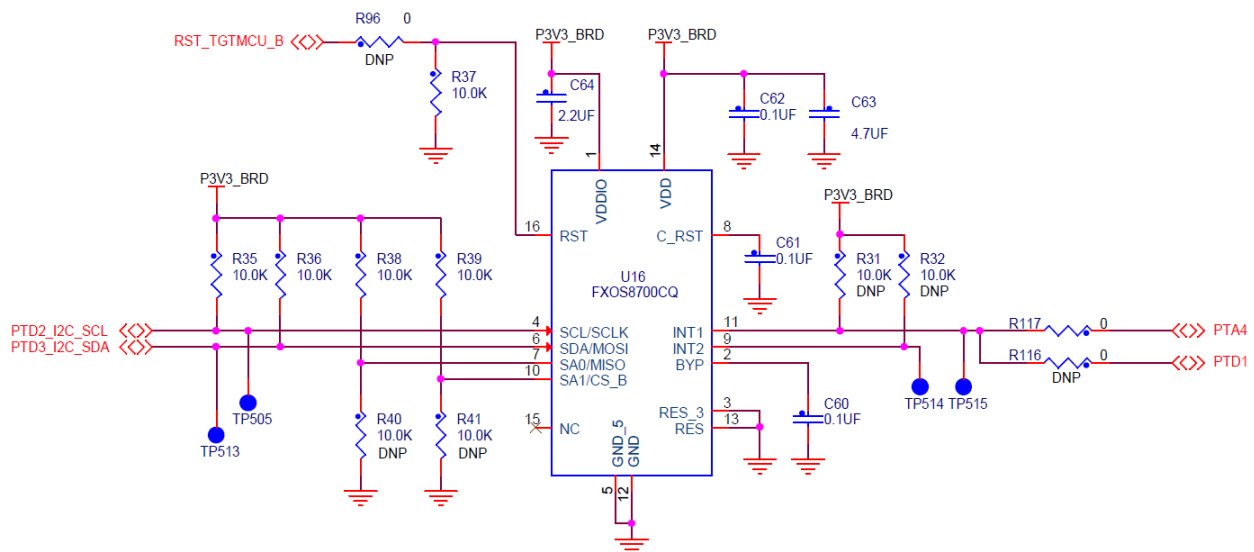

Figure 11. FXOS8700CQ combo sensor

4.2.4.3 Interface connectors J1, J2, J3 and J4

The four connectors J1, J2, J3, and J4 are 100 mil pitch, pin headers mounted on the front (component side) supporting the Freedom standard connector.

- P3V3, 5V_USB, and P5-9V_VIN provide the headers connector with its supply voltage
 - Peripheral I/O to the FRDM-KW24D512 platform and the Freedom development platform supply must use this same voltage supply to avoid potential damage.

The pin definitions for the headers are shown in [Table 3](#) and [Table 4](#).

Table 3. J2 and J1 connector

| Header pin No | J2 | Description | Header pin No | J1 | Description |
|---------------|--------------------|--------------------|---------------|--------------------|--------------------|
| | MKW24D512 pin name | | | MKW24D512 pin name | |
| 1 | NC | NC | 1 | PTE0_TX | UART1_TX |
| 2 | PTA19 | PTA19 (D8/int) | 2 | PTD7_TX | UART0 (D0/RX/INT) |
| 3 | NC | NC | 3 | PTE1_RX | UART1_RX |
| 4 | PTA18/EXTAL0 | PTA18 (D9/int) | 4 | PTD6_RX | UART0 (D1/TX/INT) |
| 5 | NC | NC | 5 | PTE2_CTS | UART1_CTS |
| 6 | PTC4_SPI_SS | PTC4 (D10/SPI_SS) | 6 | PTD5_CTS | UART0 (D2/INT) |
| 7 | NC | NC | 7 | PTE3_RST | UART1_RST |
| 8 | PTC6_SPI_SOUT | PTC6 (D11/MOSI) | 8 | PTD4_RST | UART0 (D3/PWM/INT) |
| 9 | NC | NC | 9 | NC | NC |
| 10 | PTC7_SPI_SIN | PTC7 (D12/MISO) | 10 | GPIO2 | GPIO2 (D4/INT) |
| 11 | NC | NC | 11 | NC | NC |
| 12 | PTC5_SPI_CLK | PTC5 (D13/SCK) | 12 | GPIO1 | GPIO1 (D5/PWM/INT) |
| 13 | NC | NC | 13 | NC | NC |
| 14 | GND | GND | 14 | PTE4 | PTE4 |
| 15 | NC | NC | 15 | NC | NC |
| 16 | P3V3_BRD | P3V3_BRD | 16 | PTD1 | PTD1 (D7/CMP/INT) |
| 17 | NC | NC | — | — | — |
| 18 | PTD3_I2C_SDA | PTD3 (D14/Ana/Int) | — | — | — |
| 19 | NC | NC | — | — | — |
| 20 | PTD2_I2C_SCL | PTD2 (D15/Ana/Int) | — | — | — |

Table 4. J3 and J4 connector

| Header pin No | J3 | Description | Header pin No | J4 | Description |
|---------------|--------------------|---------------------|---------------|--------------------------|-------------|
| | MKW24D512 pin name | | | MKW24D512 pin name | |
| 1 | NC | NC | 1 | NC | NC |
| 2 | NC | NC | 2 | ANT_A | A0/INT |
| 3 | NC | NC | 3 | PTA0 | JTAG_TCLK |
| 4 | P3V3 | P3V3 | 4 | ANT_B | A1/INT |
| 5 | NC | NC | 5 | PTA1 | JTAG_TDI |
| 6 | RST_B | RST_TGTMCU_B | 6 | RX_SWITCH | A2/INT |
| 7 | NC | NC | 7 | PTA2 | JTAG_TDO |
| 8 | P3V3 | P3V3 | 8 | TX_SWITCH | A3_INT |
| 9 | NC | NC | 9 | PTA3 and RST_TGTMCU_B | JTAG_TMS |
| 10 | P5V | P5V | 10 | NC | NC |
| 11 | NC | NC | 11 | PTA4 | NMI_B |
| 12 | GND | GND | 12 | NC | NC |
| 13 | NC | NC | — | — | — |
| 14 | GND | GND | — | — | — |
| 15 | NC | NC | — | — | — |
| 16 | P5-9V_VIN | Unregulated Voltage | — | — | — |

4.3 Schematic, platform layout, and bill of material

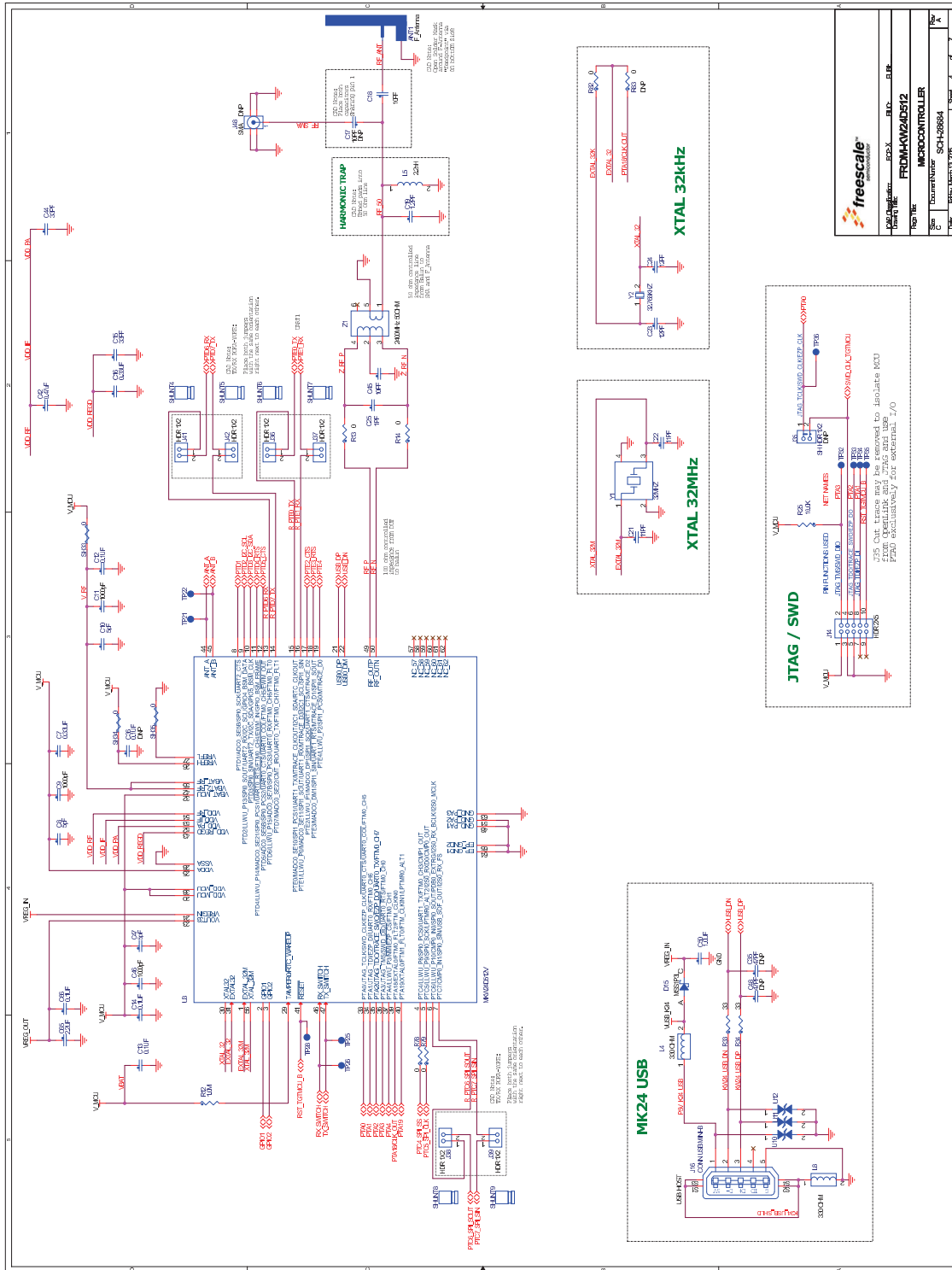
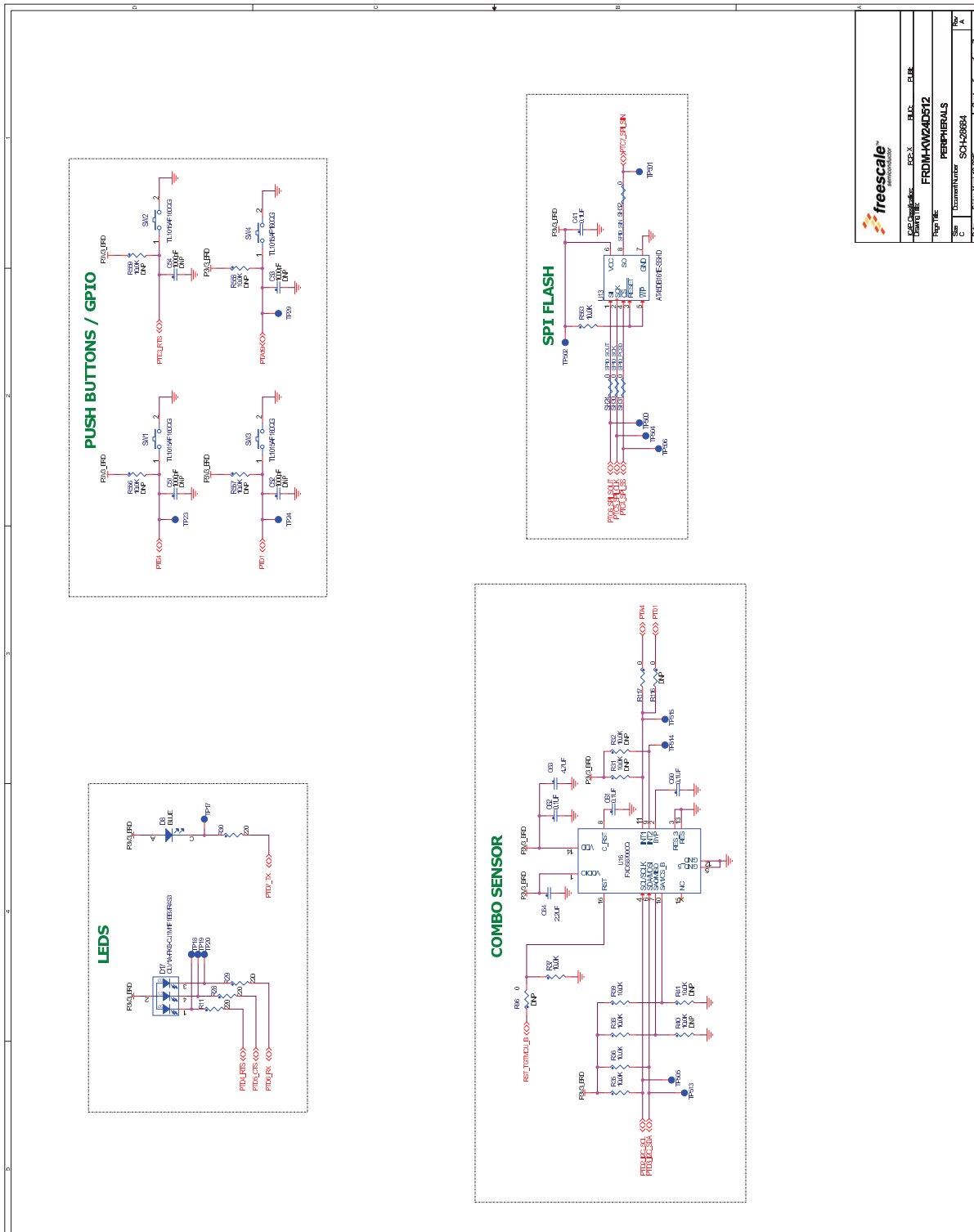

Figure 12. FRDM-KW24D512 platform schematic rev. A (1/4)



| | |
|------------------------------------|-----------------------|
| freescale SEMICONDUCTORS | |
| Doc ID: FRDM-KW24D512 | Rev: 1.0 |
| Doc Title: FRDM-KW24D512 | Doc Type: PERIPHERALS |
| Doc No: SCH-20894 | Doc Date: 05/2016 |
| Doc No: SCH-20894 | Doc Date: 05/2016 |

Figure 13. FRDM-KW24D512 platform schematic rev. A (2/4)

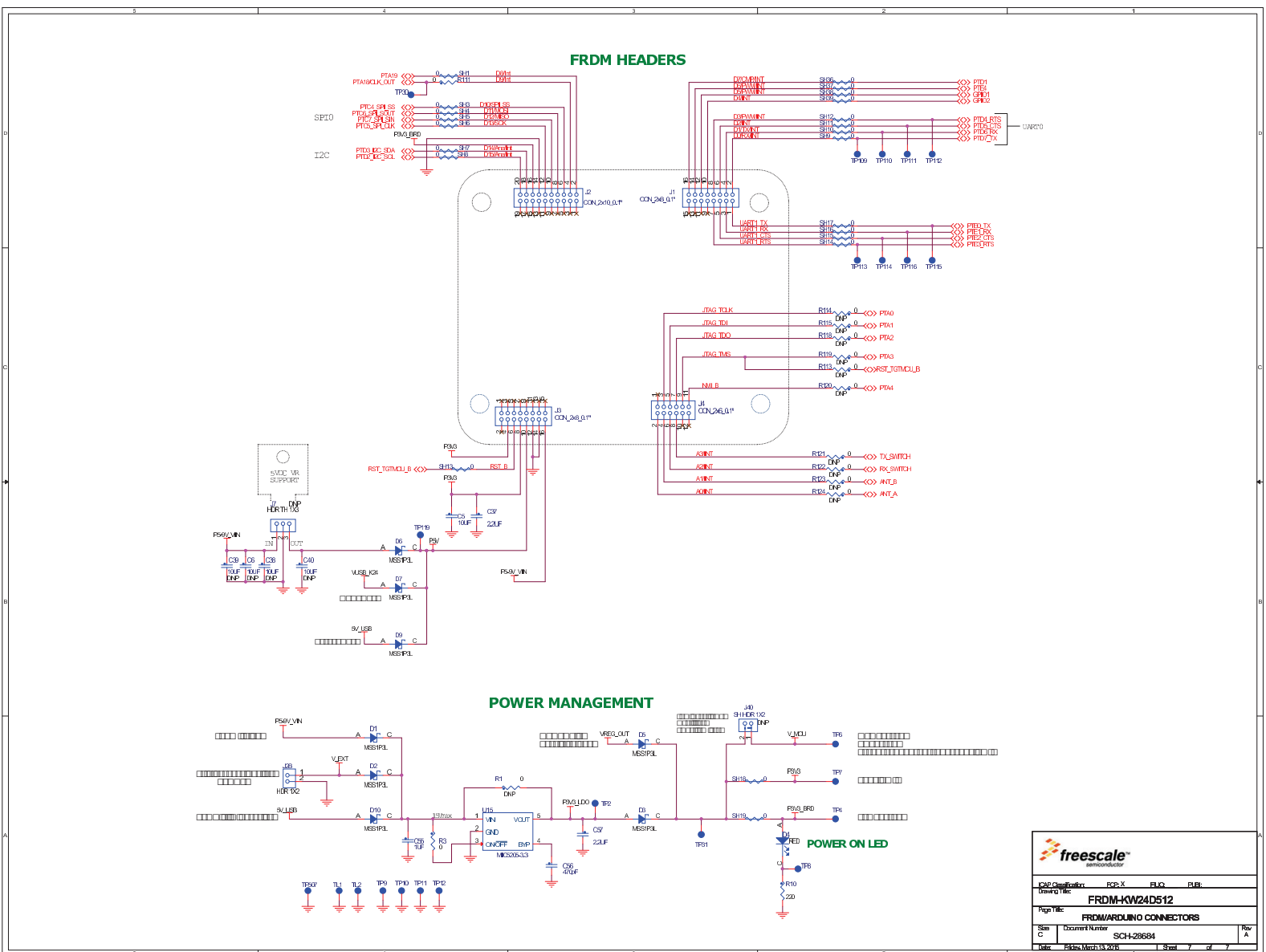

Figure 15. FRDM-KW24D512 platform schematic rev. A (4/4)

| | |
|-------------------------|------------------|
| | |
| ICAD Configuration: | FRD-Y ELD ELD |
| Drawn By: | |
| Page Title: | FRDM-KW24D512 |
| FRDM/ARDUINO CONNECTORS | |
| Sheet: | Document Number: |
| C: | SCH-28684 |
| Date: | Rev: |
| 18 Dec 2016 | A |

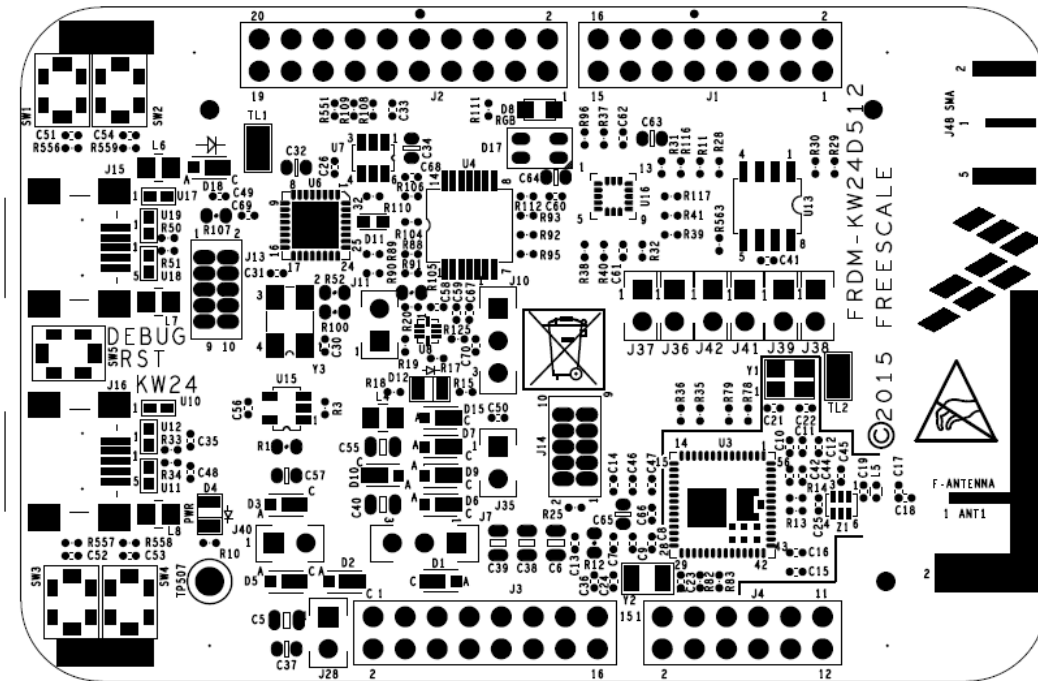

Figure 16. FRDM-KW24D512 platform PCB component location (top view)

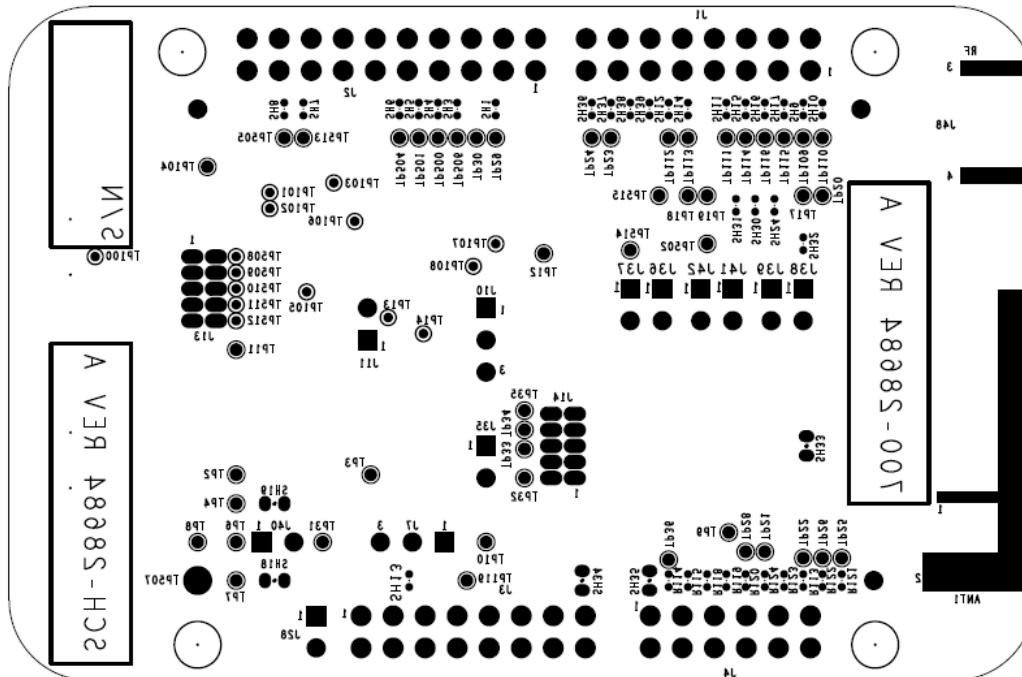

Figure 17. FRDM-KW24D512 platform PCB test points

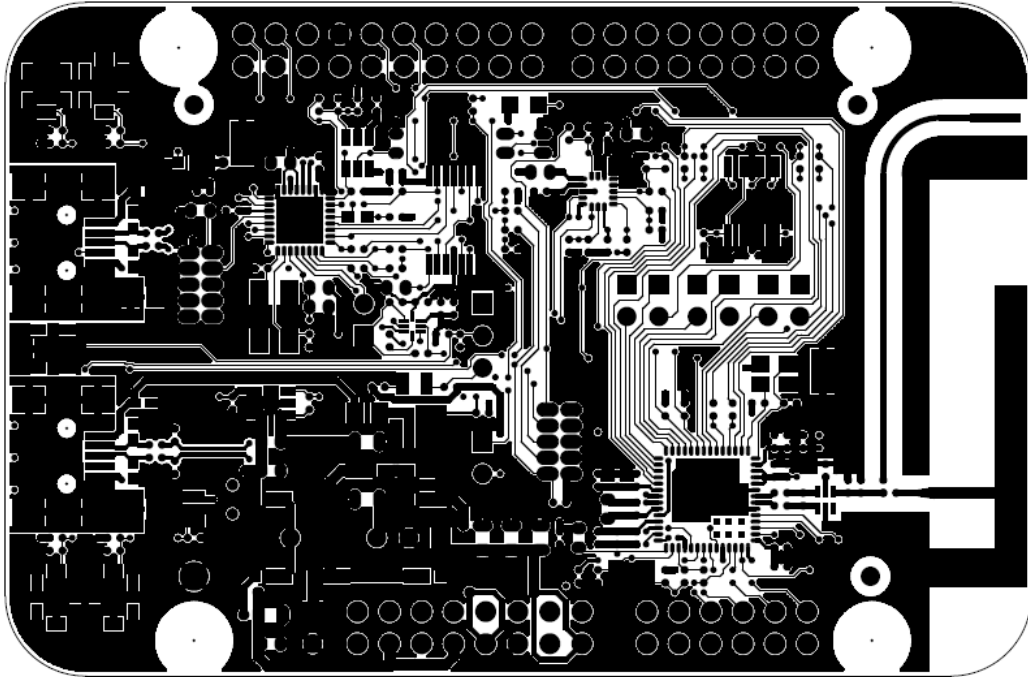

Figure 18. FRDM-KW24D512 platform PCB layout (top view)

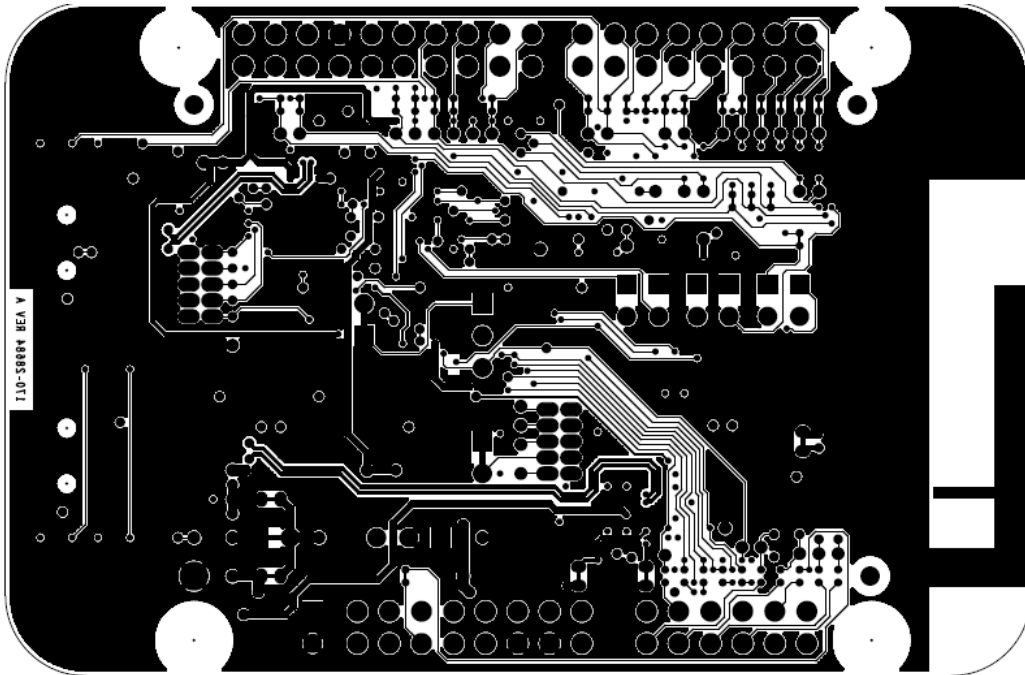

Figure 19. FRDM-KW24D512 platform PCB layout (bottom view)

4.3.1 Bill of materials

Table 5. Bill of materials (common parts for all frequency bands) (Sheet 1 of 4)

| Item | Qty | Reference | Value | Description | Mfg. name | Mfg. part number |
|------|-----|---|--------------------------|--|------------------------|--------------------------|
| 1 | 1 | ANT1 | F_ANTENNA | PCB F ANTENNA, NO PART ORDER | NOT A PART | NOT A PART |
| 2 | 1 | C25 | 1PF | CAP CER 1PF 50V ±0.05PF C0G 0402 | MURATA | GRM1555C1H1R0WA01D |
| 3 | 1 | C19 | 1.2PF | CAP CER 1.2PF 50V ±0.PF NP0 0402 | MURATA | GRM1555C1H1R2WA01D |
| 4 | 3 | C8,C10,C47 | 5PF | CAP CER 5PF 50V 5% C0G 0402 | MURATA | GJM1555C1H5R0CB01D |
| 5 | 2 | C18,C45 | 10PF | CAP CER 10PF 50V 5% C0G 0402 | AVX | 04025A100JAT2A |
| 6 | 1 | C17 DNP | 10PF | CAP CER 10PF 50V 5% C0G 0402 | AVX | 04025A100JAT2A |
| 7 | 2 | C21,C22 | 11PF | CAP CER 11PF 50V 5% C0G 0402 | KEMET | CBR04C110F5GAC |
| 8 | 2 | C23,C24 | 12PF | CAP CER 12PF 50V 5% C0G 0402 | MURATA | GRM1555C1H120JZ01D |
| 9 | 1 | C34 DNP | 18PF | CAP CER 18PF 50V 5% C0G 0603 | YAGEO AMERICA | CC0603JRNPO9BN180 |
| 10 | 2 | C30,C31 DNP | 22PF | CAP CER 22PF 50V 5% C0G 0402 | AVX | 04025A220JAT2A |
| 11 | 2 | C15,C44 | 33PF | CAP CER 33PF 50V 5% C0G 0402 | KEMET | C0402C330J5GACTU |
| 12 | 2 | C35,C48 DNP | 47PF | CAP CER 47PF 16V 5% C0G 0402 | AVX | 0402YA470JAT2A |
| 13 | 1 | C56 | 470PF | CAP CER 470PF 16V 10% X7R 0402 | KEMET | C0402C471K4RACTU |
| 14 | 4 | C9,C11,C46,C70 | 1000PF | CAP CER 1000PF 50V 5% C0G 0402 | MURATA | GRM1555C1H102JA01D |
| 15 | 4 | C51,C52,C53,C54 DNP | 1000PF | CAP CER 1000PF 50V 5% C0G 0402 | MURATA | GRM1555C1H102JA01D |
| 16 | 11 | C12,C13,C14,C33,C41,C59,C60,C61,C62,C66,C68 | 0.1UF | CAP CER 0.1UF 16V 10% X7R 0402 | KEMET | C0402C104K4RAC |
| 17 | 2 | C36,C69 DNP | 0.1UF | CAP CER 0.1UF 16V 10% X7R 0402 | KEMET | C0402C104K4RAC |
| 18 | 2 | C7,C16 | 0.33UF | CAP CER 0.33UF 6.3V 10% X5R 0402 | MURATA | GRM155R60J334KE01D |
| 19 | 1 | C42 | 0.47UF | CAP CER 0.47UF 6.3V 10% X5R 0402 | KEMET | C0402C474K9PACTU |
| 20 | 3 | C26,C49,C50 | 1.0UF | CAP CER 1.0UF 10V 10% X5R 0402 | YAGEO AMERICA | CC0402KRX5R6BB105 |
| 21 | 1 | C55 | 1UF | CAP CER 1UF 10V 10% X7R 0805 | MURATA | GRM21BR71A105KA01L |
| 22 | 5 | C32,C37,C57,C64,C65 | 2.2UF | CAP CER 2.2UF 10V 10% X7R 0603 | TAIYO YUDEN | LMK107B7225KA-T |
| 23 | 2 | C58,C67 | 4.7UF | CAP CER 4.7UF 6.3V 20% X5R 0402 | MURATA | GRM155R60J475ME47D |
| 24 | 1 | C63 | 4.7UF | CAP CER 4.7UF 10V 10% X7R 0603 | KEMET | C0603C475K8PACTU |
| 25 | 1 | C5 | 10UF | CAP CER 10UF 10V 10% X7R 0805 | MURATA | GRM21BR71A106KE51L |
| 26 | 4 | C6,C38,C39,C40 DNP | 10UF | CAP CER 10UF 10V 10% X7R 0805 | MURATA | GRM21BR71A106KE51L |
| 27 | 10 | D1,D2,D3,D5,D6,D7,D9,D10,D15,D18 | MSS1P3L | DIODE SCH 1A 20V MICROSMP SMT | VISHAY INTERTECHNOLOGY | MSS1P3L-M3/89A |
| 28 | 2 | D4,D12 | RED | LED RED SGL 20MA SMT 0805 | LITE ON | LTST-C171KRKT |
| 29 | 1 | D8 | BLUE | LED BLUE SGL 20MA SMT 0805 | LITE ON | LTST-C171TBKT |
| 30 | 1 | D11 | LED GREEN | LED GRN SGL 20MA 0603 | OSRAM | LG L29K-G2J1-24-Z |
| 31 | 1 | D17 | CLV1A-FKB-CJ1M1F1BB7R4S3 | LED - RGB, CLV1A-FKB-CJ1M1F1BB7R4S3, 675/527/470MCD(TYP.), SMD | CREE | CLV1A-FKB-CJ1M1F1BB7R4S3 |

Table 5. Bill of materials (common parts for all frequency bands) (Sheet 2 of 4)

| Item | Qty | Reference | Value | Description | Mfg. name | Mfg. part number |
|------|-----|--|--------------------|--|---------------------------|-------------------|
| 32 | 2 | J1,J3 | CON_2X8_0.1" | CON 2X8 FEMALE 100MIL SP 394H AU | SAMTEC | SSW-108-03-G-D |
| 33 | 1 | J2 | CON_2X10_0.1" | CON 2X10 FEMALE 100MIL SP 394H AU | SAMTEC | SSW-110-03-G-D |
| 34 | 1 | J4 | CON_2X6_0.1" | CON 2X6 FEMALE 100MIL SP 394H AU | SAMTEC | SSW-106-03-G-D |
| 35 | 1 | J7 DNP | HDR TH 1X3 | HDR 1X3 TH 100MIL SP 339H AU 100L | SAMTEC | TSW-103-07-G-S |
| 36 | 1 | J10 | HDR TH 1X3 | HDR 1X3 TH 100MIL SP 339H AU 100L | SAMTEC | TSW-103-07-G-S |
| 37 | 3 | J11,J35,J40 DNP | SH HDR 1X2 | HDR 1X2 TH 100MIL SP 330H SN 115L (BOTTOM SIDE SHORT) | SAMTEC | TSW-102-23-T-S |
| 38 | 2 | J13,J14 | HDR 2X5 | CONN,HEAD,2X5,STR,50/50 CON-2RH-10-50 | SAMTEC | FTS-105-01-F-D |
| 39 | 2 | J15,J16 | CONN USB MINI-B | CON 5 USB_MINI_B_RECEPTACLE RA SMT 0.8MM 168H AU | TE CONNECTIVITY LTD | 1734035-2 |
| 40 | 7 | J28,J36,J37,J38,J39, J41,J42 | HDR 1X2 | HDR 1X2 TH 100MIL SP 330H SN 115L | SAMTEC | TSW-102-23-T-S |
| 41 | 1 | J48 DNP | SMA | CON, SMA, EDGE 0.062IN, 50 OHM FEMALE 18GHZ | JOHNSON COMPONENTS INC | 142-0701-851 |
| 42 | 4 | L4,L6,L7,L8 | 330 OHM | IND FER BEAD 330OHM@100MHZ 2.5A -- SMT | TDK | MPZ2012S331A |
| 43 | 1 | L5 | 2.2NH | IND -- 0.0022UH@100MHZ 300MA 0.0003UH 0402 | MURATA | LQG15HS2N2S02D |
| 44 | 9 | R3,R13,R14,R78, R79,R82,R95,R111, R117 | 0 | RES MF ZERO OHM 1/16W 5% 0402 | VISHAY | CRCW04020000Z0ED |
| 45 | 14 | R17,R83,R96,R113, R114,R115,R116, R118,R119,R120, R121,R122,R123, R124 DNP | 0 | RES MF ZERO OHM 1/16W 5% 0402 | VISHAY | CRCW04020000Z0ED |
| 46 | 1 | R1 DNP | 0 | RES MF ZERO OHM 1/10W -- 0603 | VISHAY INTERTECHNOLOGY | CRCW06030000Z0EA |
| 47 | 4 | R33,R34,R50,R51 | 33 | RES MF 33.0 OHM 1/16W 1% 0402 | VISHAY | CRCW040233R0FKED |
| 48 | 7 | R10,R11,R18,R28, R29,R30,R104 | 220 | RES MF 220 OHM 1/16W 5% 0402 | VISHAY INTERTECHNOLOGY | CRCW0402220RJNED |
| 49 | 5 | R88,R89,R92,R93, R551 | 1.0K | RES MF 1.0K 1/16W 1% 0402 | YAGEO AMERICA | RC0402FR-071KL |
| 50 | 2 | R90,R91 DNP | 1.0K | RES MF 1.0K 1/16W 1% 0402 | YAGEO AMERICA | RC0402FR-071KL |
| 51 | 1 | R52 | 4.7K | RES MF 4.7K 1/10W 5% 0603 | VISHAY INTERTECHNOLOGY | CRCW06034K70JNEA |
| 52 | 10 | R19,R20,R25,R35, R36,R37,R38,R39, R110,R563 | 10.0K | RES MF 10.0K 1/16W 1% AEC-Q200 0402 | VISHAY INTERTECHNOLOGY | CRCW040210K0FKED |
| 53 | 9 | R31,R32,R40,R41, R108,R556,R557, R558,R559 DNP | 10.0K | RES MF 10.0K 1/16W 1% AEC-Q200 0402 | VISHAY INTERTECHNOLOGY | CRCW040210K0FKED |
| 54 | 3 | R100,R105,R107 | 10K | RES MF 10K 1/10W 5% 0603 | KOA SPEER | RK73B1JTDD103J |
| 55 | 1 | R109 | 15K | RES MF 15.0K 1/16W 1% 0402 | BOURNS | CR0402-FX-1502GLF |
| 56 | 1 | R125 DNP | 15K | RES MF 15.0K 1/16W 1% 0402 | BOURNS | CR0402-FX-1502GLF |
| 57 | 1 | R106 | 27K | RES MF 27K 1/16W 5% 0402 | VISHAY INTERTECHNOLOGY | CRCW040227K0JNED |

Table 5. Bill of materials (common parts for all frequency bands) (Sheet 3 of 4)

| Item | Qty | Reference | Value | Description | Mfg. name | Mfg. part number |
|------|-----|---|--------------------|---|----------------------------|------------------|
| 58 | 1 | R112 DNP | 27K | RES MF 27K 1/16W 5% 0402 | VISHAY INTERTECHNOLOGY | CRCW040227K0JNED |
| 59 | 1 | R15 | 180K | RES MF 180K 1/16W 1% 0402 | VISHAY | CRCW0402180KFED |
| 60 | 1 | R12 | 1.0M | RES MF 1.0M 1/10W 5% 0603 | BOURNS | CR0603-JW-105ELF |
| 61 | 1 | SHUNT3 | SHUNT | SHUNT 2.54MM 2POS | 3M | 969102-0000-DA |
| 62 | 1 | SHUNT4 | SHUNT | SHUNT 2.54MM 2POS | 3M | 969102-0000-DA |
| 63 | 1 | SHUNT5 | SHUNT | SHUNT 2.54MM 2POS | 3M | 969102-0000-DA |
| 64 | 1 | SHUNT6 | SHUNT | SHUNT 2.54MM 2POS | 3M | 969102-0000-DA |
| 65 | 1 | SHUNT7 | SHUNT | SHUNT 2.54MM 2POS | 3M | 969102-0000-DA |
| 66 | 1 | SHUNT8 | SHUNT | SHUNT 2.54MM 2POS | 3M | 969102-0000-DA |
| 67 | 1 | SHUNT9 | SHUNT | SHUNT 2.54MM 2POS | 3M | 969102-0000-DA |
| 68 | 24 | SH1,SH3,SH4,SH5, SH6,SH7,SH8,SH9, SH10,SH11,SH12, SH13,SH14,SH15, SH16,SH17,SH24, SH30,SH31,SH32, SH36,SH37,SH38, SH39 | 0 | CUT TRACE RESISTOR | NOT A COMPONENT | NOT A COMPONENT |
| 69 | 5 | SH18,SH19,SH33, SH34,SH35 | 0 | CUT TRACE RESISTOR | NOT A COMPONENT | NOT A COMPONENT |
| 70 | 5 | SW1,SW2,SW3, SW4,SW5 | TL1015AF160Q G | SW SPST-NO 0.05A, 12V, SMT | E-SWITCH | TL1015AF160QG |
| 71 | 2 | TL1,TL2 | TESTLOOP | TEST POINT PAD SIZE 3.4MM X 1.8MM SMT | KEystone ELECTRONICS | 5015 |
| 72 | 48 | TP2,TP3,TP4,TP6, TP7,TP8,TP9,TP10, TP11,TP12,TP17, TP18,TP19,TP20, TP21,TP22,TP23, TP24,TP25,TP26, TP28,TP29,TP30, TP31,TP32,TP33, TP34,TP35,TP36, TP104,TP109, TP110,TP111,TP112, TP113,TP114,TP115, TP116,TP119,TP500, TP501,TP502, TP504,TP505, TP506,TP513, TP514,TP515 | TPAD_040 | TEST POINT PAD 40MIL DIA SMT, NO PART TO ORDER | NOT A COMPONENT | NOT A COMPONENT |
| 73 | 15 | TP13,TP14,TP100, TP101,TP102, TP103,TP105, TP106,TP107, TP108,TP508, TP509,TP510, TP511,TP512 | TPAD_030 | TEST POINT PAD 30MIL DIA SMT, NO PART TO ORDER | NOT A COMPONENT | NOT A COMPONENT |
| 74 | 1 | TP507 | TESTLOOP_B LACK | TEST POINT PC MULTI PURPOSE BLK TH | KEystone ELECTRONICS | 5011 |
| 75 | 1 | U3 | MKW24D512V | IC MCU XCVR 2.4GHZ 64KB RAM 512KB FLASH - USB 1.8-3.6V LGA63 | FREESCALE SEMICONDUCTOR | MKW24D512VHA5 |
| 76 | 1 | U4 | 74LVC125ADB | IC BUF QUAD TS 1.2-3.6V SSOP14 | NXP SEMICONDUCTORS | 74LVC125ADB |