



Chipsmall Limited consists of a professional team with an average of over 10 year of expertise in the distribution of electronic components. Based in Hongkong, we have already established firm and mutual-benefit business relationships with customers from,Europe,America and south Asia,supplying obsolete and hard-to-find components to meet their specific needs.

With the principle of “Quality Parts,Customers Priority,Honest Operation,and Considerate Service”,our business mainly focus on the distribution of electronic components. Line cards we deal with include Microchip,ALPS,ROHM,Xilinx,Pulse,ON,Everlight and Freescale. Main products comprise IC,Modules,Potentiometer,IC Socket,Relay,Connector.Our parts cover such applications as commercial,industrial, and automotives areas.

We are looking forward to setting up business relationship with you and hope to provide you with the best service and solution. Let us make a better world for our industry!



Contact us

Tel: +86-755-8981 8866 Fax: +86-755-8427 6832

Email & Skype: info@chipsmall.com Web: www.chipsmall.com

Address: A1208, Overseas Decoration Building, #122 Zhenhua RD., Futian, Shenzhen, China



THIS COPY IS PROVIDED ON A RESTRICTED BASIS AND IS NOT TO BE USED IN ANY WAY DETRIMENTAL TO THE INTERESTS OF PANDUIT CORP.

PANDUIT PART NUMBER	WEIGHT
FRSTRC**	.42 LBS (.19 kg)

NOTES:

- VISIT OUR ON-LINE CATALOG AT WWW.PANDUIT.COM FOR A LIST OF CURRENT PARTS APPLICABLE FOR USE WITH THIS PRODUCT.
- THE FIBERRUNNER STRUT CLIP KIT ALLOWS FOR ALL SIZES EXCEPT 2X2 OF FIBERRUNNER PATHWAYS. IT ALSO ALLOWS FOR ANY SIZE OF WYR-GRID PATHWAY TO BE INSTALLED DIRECTLY TO 15/8" WIDE STRUT METAL FRAMING CHANNEL.
- THE FIBERRUNNER STRUT CLIP KIT INCLUDES:
TWO (2) CLIPS,
TWO (2) 1/4-20 CHANNEL NUTS WITHOUT SPRINGS,
TWO (2) 1/4-20x7/8 HEX HEAD CAP SCREWS,
TWO (2) 1/4 HELICAL SPRING LOCKWASHERS.
- DIMENSIONS IN PARENTHESES ARE IN INCHES.

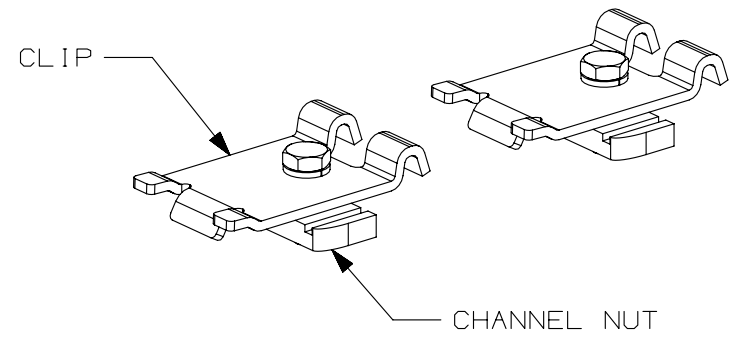
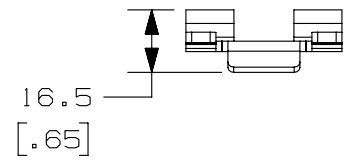
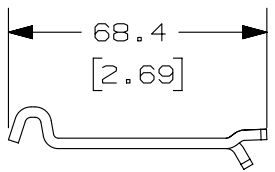
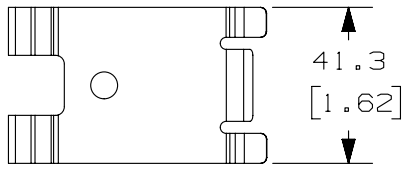

00A	1-7-15	TWV	DWR		RELEASED TO PRODUCTION				V09000DB
REV	DATE	BY	CHK	APR	DESCRIPTION	ECN			

TITLE				FIBERRUNNER STRUT CLIP KIT (FRSTRC**) CUSTOMER DRAWING			
ITEM REVISION NAME				14D419AK/00			
DATASET FILE NAME				14D419AK_DC/00A FRSTRC**			
UNLESS OTHERWISE SPECIFIED, DIMENSIONAL TOLERANCES ARE:				MATERIAL:			
INCHES		METRIC - MILLIMETER		ANGLE		STEEL	
X.X	+/- 0.18	X.	+/- 0.57				
X.XX	+/- 0.10	X.X	+/- 0.54		+/- 1°		
X.XXX	+/- 0.036	X.XX	+/- 0.92				
DRAWING NUMBER:				14D419AK-DC			
DRAWN BY		DATE		CHK		SCALE	
TWV		1-7-15		DWR		NONE	
SHT 1 OF 1				A			