



Chipsmall Limited consists of a professional team with an average of over 10 year of expertise in the distribution of electronic components. Based in Hongkong, we have already established firm and mutual-benefit business relationships with customers from,Europe,America and south Asia,supplying obsolete and hard-to-find components to meet their specific needs.

With the principle of "Quality Parts,Customers Priority,Honest Operation,and Considerate Service",our business mainly focus on the distribution of electronic components. Line cards we deal with include Microchip,ALPS,ROHM,Xilinx,Pulse,ON,Everlight and Freescale. Main products comprise IC,Modules,Potentiometer,IC Socket,Relay,Connector.Our parts cover such applications as commercial,industrial, and automotives areas.

We are looking forward to setting up business relationship with you and hope to provide you with the best service and solution. Let us make a better world for our industry!



## Contact us

Tel: +86-755-8981 8866 Fax: +86-755-8427 6832

Email & Skype: info@chipsmall.com Web: www.chipsmall.com

Address: A1208, Overseas Decoration Building, #122 Zhenhua RD., Futian, Shenzhen, China



## Description

The FS1012 MEMS mass flow sensor module measures the flow rate using the thermo-transfer (calorimetric) principle. The FS1012 is capable of measuring a gas or liquid medium.

The FS1012 offers key advantages over resistor-based flow solutions. The sensor utilizes thermopile sensing, which provides an excellent signal-to-noise ratio. The sensor comprises a “solid” thermal isolation technology and silicon-carbide coating to protect it from abrasive wear and provides robustness and long-term reliability. In comparison, other sensors typically contain a fragile membrane above an etched cavity for the thermal isolation base.

The FS1012 features the sensor fully assembled and wire-bonded out to a 6-pin header.

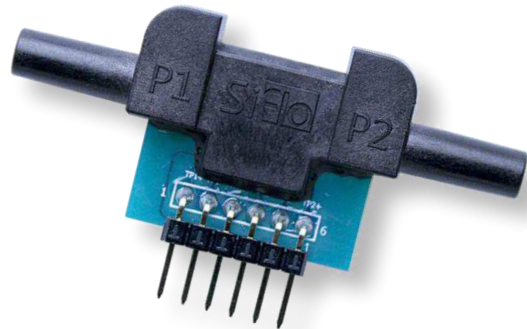
## Features

- Gas or liquid mediums
- Robust “solid” isolation technology
- Resistant to surface contamination
- No cavity to cause clogging
- Resistant to vibration and pressure shock
- Low power application
- Sensitive at low flow rates and differential pressure levels
- Fast response: 2ms
- Millivolt output
- Supply voltage: 3V to 5V
- Module operating temperature range: 0°C to +85°C

## Typical Applications

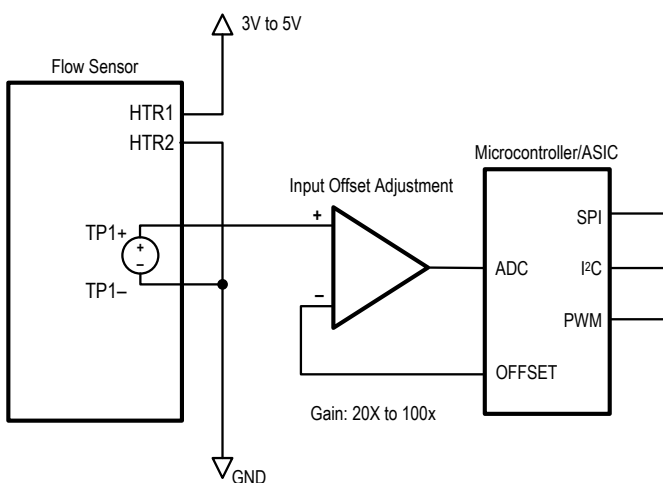
- Process controls and monitoring
- Oil and gas leak detection
- HVAC and air control systems
- CPAP and respiratory devices
- Automotive mas air flow meter
- Liquid dispensing system

## FS1012 Flow Sensor Module

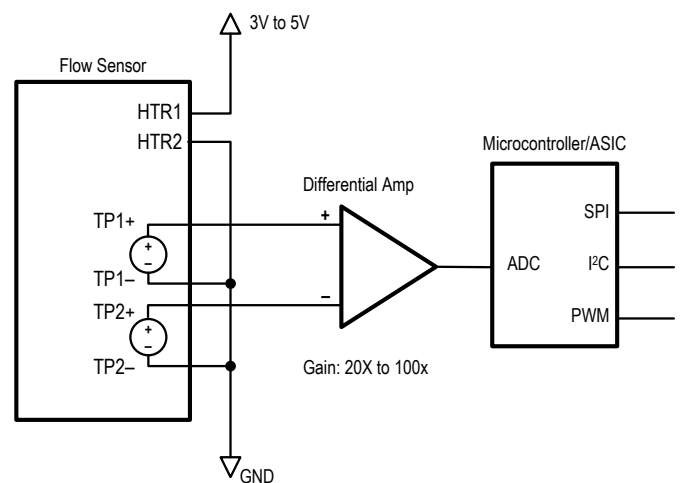


## Basic Application Circuits

**Figure 1. Single-Ended Circuit Example**

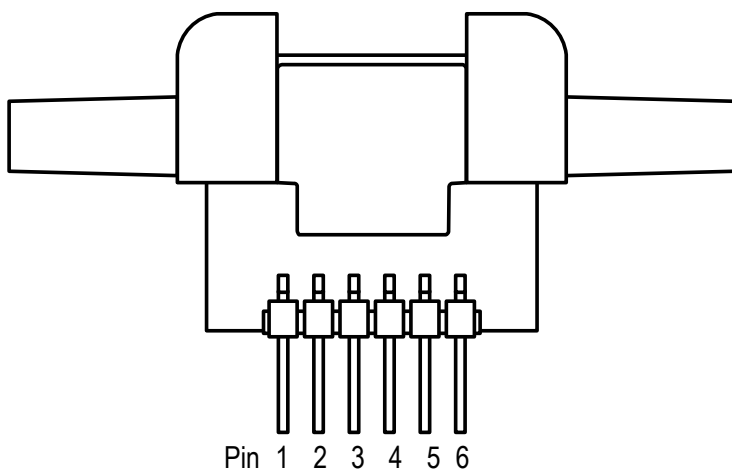


**Figure 2. Differential Circuit Example**



## Pin Assignments

**Figure 3. Pin Assignments for Module – Top View**



## Pin Descriptions

**Table 1. Pin Descriptions**

Pin Number	Pad Name	Type	Description
1	TP1+	Output	Thermopile 1 (+)
2	TP1-	Output	Thermopile 1 (-)
3	HTR1	Input	Heater
4	HTR2	Input	Heater
5	TP2-	Output	Thermopile 2 (-)
6	TP2+	Output	Thermopile 2 (+)

## Absolute Maximum Ratings

The absolute maximum ratings are stress ratings only. Stresses greater than those listed below can cause permanent damage to the device. Functional operation of the FS1012 at absolute maximum ratings is not implied. Exposure to absolute maximum rating conditions may affect device reliability.

**Table 2. Absolute Maximum Ratings**

Symbol	Parameter	Conditions	Minimum	Maximum	Units
V <sub>H</sub>	Heater Voltage Supply			5.6	V
T <sub>STOR</sub>	Storage Temperature		-50	130	°C

## Operating Conditions

**Table 3. Recommended Operating Conditions**

Symbol	Parameter	Minimum	Typical	Maximum	Units
T <sub>AMB</sub>	Ambient Operating Temperature <sup>[a]</sup>	0		85	°C
I <sub>HTR_CC</sub>	Heater Driving Current – Constant Current <sup>[a]</sup>		10	20	mA
V <sub>HTR_CV</sub>	Heater Driving Voltage – Constant Voltage <sup>[a]</sup>		3	5.6	V

[a] Sensor specifications are tested at the wafer die level.

## Electrical Characteristics

**Table 4. Electrical Characteristics**

Note: See important notes at the end of the table.

Symbol	Parameter	Conditions	Minimum	Typical	Maximum	Units
R <sub>H</sub>	Heater Resistor <sup>[a]</sup>		230	290	400	Ω
∞ <sub>HTR</sub>	Heater Temperature Coefficient of Resistance <sup>[a]</sup>			300		ppm/°C
V <sub>TP_OUT</sub>	Thermopile Output <sup>[a]</sup>	3V driving voltage, in air, 20°C, no flow	30	35	60	mV
R <sub>TP</sub>	Thermopile Resistance <sup>[a]</sup>	20°C	100	210	300	KΩ
V <sub>TP_OUTDIFF</sub>	Thermopile Differential Output <sup>[a]</sup>	3V driving voltage, in air, 20°C, no flow	-1	0	1	mV
t <sub>RESP</sub>	Response Time				2	ms

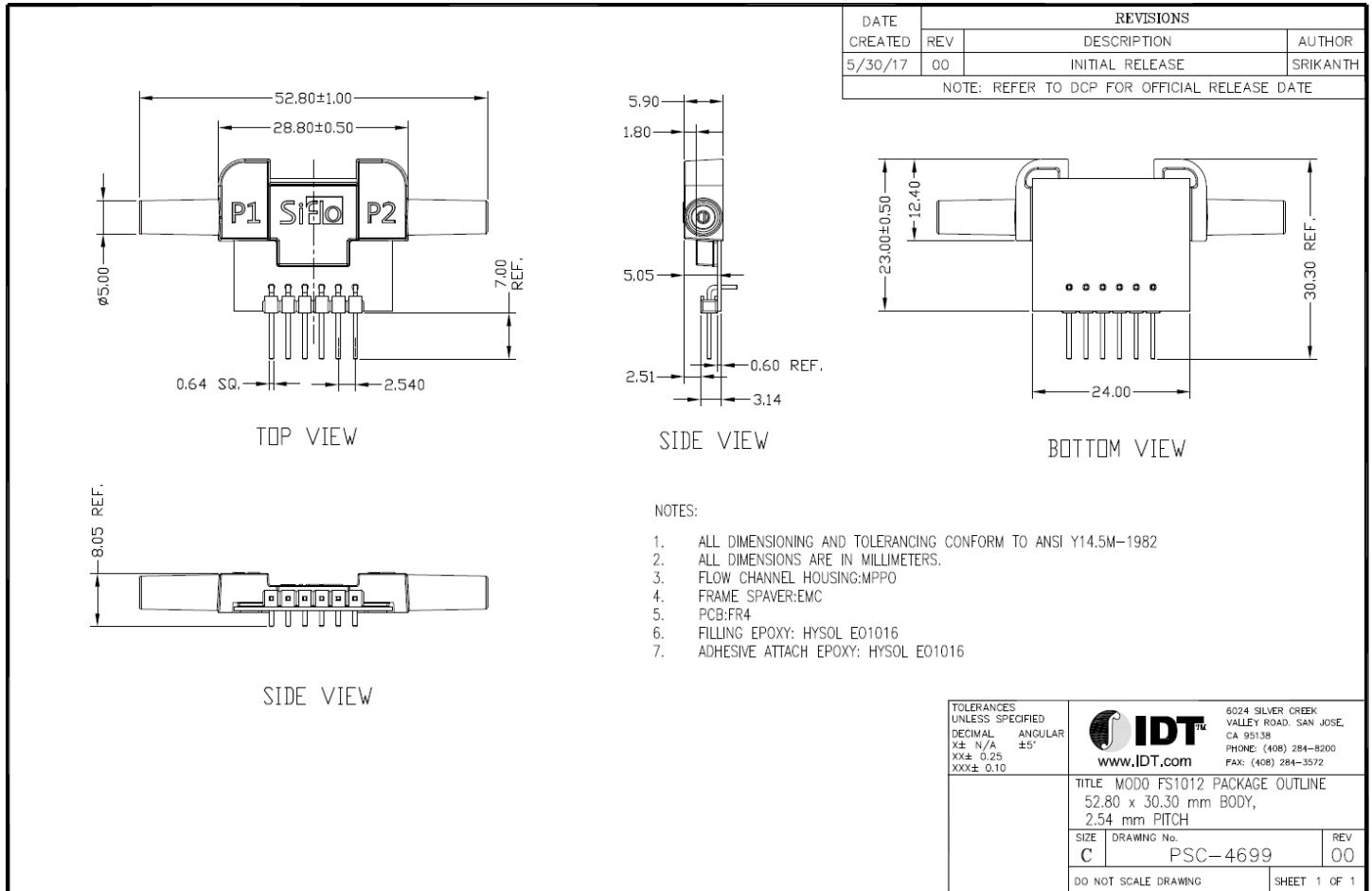
Symbol	Parameter	Conditions	Minimum	Typical	Maximum	Units
<b>Standard Gas Flow Range<sup>[b], [c]</sup></b>						
	Gas Flow	FS1012-1020-NG	0		2 (2000)	SLPM (SCCM)
		FS1012-1100-NG	0		10 (10000)	SLPM (SCCM)
<b>Standard Liquid Flow Range<sup>[b], [c]</sup></b>						
	Liquid Flow	FS1012-1001-LQ	0		0.5 (500)	SLPM (SCCM)
		FS1012-1002-LQ	0		1.0 (1000)	SLPM (SCCM)

[a] Sensor specifications are tested at the wafer die level.

[b] SLPM: Standard liter per minute.

[c] SCCM: Standard cubic centimeter per minute.

# Mechanical Drawings

**Figure 4. FS1012 Module Dimensions**


## Ordering Information

Note: The part code depends on the application. In the part code, NG refers to “non-corrosive gas” and LQ refers to “liquid.”

Orderable Part Number	Description and Package	Shipping Packaging	Temperature
FS1012-1020-NG	0 to 2 SLPM gas flow sensor mounted on a circuit board with a flow housing	Box	0°C to +85°C
FS1012-1100-NG	0 to 10 SLPM gas flow sensor mounted on a circuit board with a flow housing	Box	0°C to +85°C
FS1012-1001-LQ	0 to 0.5 SLPM (500 SCCM) liquid flow sensor mounted on a circuit board with a flow housing	Box	0°C to +85°C
FS1012-1002-LQ	0 to 1.0 SLPM (1000 SCCM) liquid flow sensor mounted on a circuit board with a flow housing	Box	0°C to +85°C

## Revision History

Revision Date	Description of Change
July 20, 2017	Initial release of the datasheet.



**Corporate Headquarters**  
 6024 Silver Creek Valley Road  
 San Jose, CA 95138  
[www.IDT.com](http://www.IDT.com)

**Sales**  
 1-800-345-7015 or 408-284-8200  
 Fax: 408-284-2775  
[www.IDT.com/go/sales](http://www.IDT.com/go/sales)

**Tech Support**  
[www.IDT.com/go/support](http://www.IDT.com/go/support)

DISCLAIMER Integrated Device Technology, Inc. (IDT) and its affiliated companies (herein referred to as "IDT") reserve the right to modify the products and/or specifications described herein at any time, without notice, at IDT's sole discretion. Performance specifications and operating parameters of the described products are determined in an independent state and are not guaranteed to perform the same way when installed in customer products. The information contained herein is provided without representation or warranty of any kind, whether express or implied, including, but not limited to, the suitability of IDT's products for any particular purpose, an implied warranty of merchantability, or non-infringement of the intellectual property rights of others. This document is presented only as a guide and does not convey any license under intellectual property rights of IDT or any third parties.

IDT's products are not intended for use in applications involving extreme environmental conditions or in life support systems or similar devices where the failure or malfunction of an IDT product can be reasonably expected to significantly affect the health or safety of users. Anyone using an IDT product in such a manner does so at their own risk, absent an express, written agreement by IDT.

Integrated Device Technology, IDT and the IDT logo are trademarks or registered trademarks of IDT and its subsidiaries in the United States and other countries. Other trademarks used herein are the property of IDT or their respective third party owners. For datasheet type definitions and a glossary of common terms, visit [www.idt.com/go/glossary](http://www.idt.com/go/glossary). All contents of this document are copyright of Integrated Device Technology, Inc. All rights reserved.