



Chipsmall Limited consists of a professional team with an average of over 10 year of expertise in the distribution of electronic components. Based in Hongkong, we have already established firm and mutual-benefit business relationships with customers from,Europe,America and south Asia,supplying obsolete and hard-to-find components to meet their specific needs.

With the principle of “Quality Parts,Customers Priority,Honest Operation,and Considerate Service”,our business mainly focus on the distribution of electronic components. Line cards we deal with include Microchip,ALPS,ROHM,Xilinx,Pulse,ON,Everlight and Freescale. Main products comprise IC,Modules,Potentiometer,IC Socket,Relay,Connector.Our parts cover such applications as commercial,industrial, and automotives areas.

We are looking forward to setting up business relationship with you and hope to provide you with the best service and solution. Let us make a better world for our industry!



Contact us

Tel: +86-755-8981 8866 Fax: +86-755-8427 6832

Email & Skype: info@chipsmall.com Web: www.chipsmall.com

Address: A1208, Overseas Decoration Building, #122 Zhenhua RD., Futian, Shenzhen, China



Description

The FS1025 MEMS Liquid Flow Sensor Module measures the flow rate using the thermo-transfer (calorimetric) principle. The FS1025 is designed to measure liquids.

The FS1025 offers key advantages over resistor-based flow solutions. The sensor utilizes thermopile sensing, which provides an excellent signal-to-noise ratio. The sensor comprises a “solid” thermal isolation technology and silicon-carbide coating, which protects it from abrasive wear and provides robustness and long-term reliability. In comparison, other sensors typically contain a fragile membrane above an etched cavity for the thermal isolation base.

There are no moving mechanical parts that can break in contrast to other flow meter types, such as a turbine-type meter. The FS1025 has minimal flow resistance, making it highly suitable for gravity-feed applications or for replacing a high-power pump with a lower power device.

The FS1025 complies with the *NSF/ANSI 61: Drinking Water System Components – Health Effects* standard.

Typical Applications

- Beverage equipment
- Liquid-dispensing system
- Process controls and monitoring
- Fluid leak detection

Features

- Liquid flow: 0 to 7 liters/min
- Robust “solid” isolation technology
- Resistant to surface contamination
- No cavity to cause clogging
- Resistant to vibration and pressure shock
- Low-power application
- Minimal flow resistance
- Fast response: < 5ms
- Flow voltage output: 0V to 4.5V (uncalibrated)
- Thermistor voltage output: 1V to 4.5V
- Supply voltage: 5V
- Module operating temperature range: 5°C to +75°C

FS1025 Flow Sensor Module

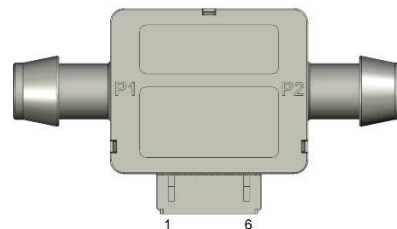

Pin Assignments

Figure 1. Pin Assignments for Module – Top View

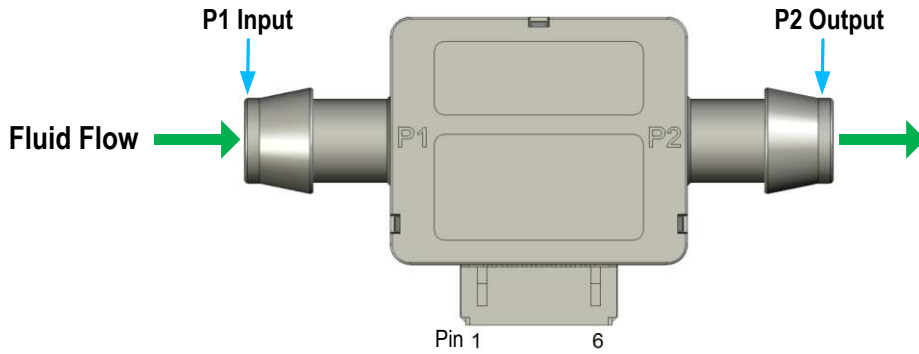

Pin Descriptions

Table 1. Pin Descriptions

Pin Number	Pad Name	Type	Description
1	VDD	In	Supply voltage
2	GND	In	Ground
3	OUTPUT	Out	Flow analog output
4	NC	—	Do not connect ^[a]
5	HE	In	Heater enable, +5V
6	TEMP	Out	Thermistor analog output

[a] “NC” stands for not connected / no connection required / not bonded.

Absolute Maximum Ratings

The absolute maximum ratings are stress ratings only. Stresses greater than those listed below can cause permanent damage to the device. Functional operation of the FS1025 at absolute maximum ratings is not implied. Exposure to absolute maximum rating conditions might affect device reliability.

Table 2. Absolute Maximum Ratings

Symbol	Parameter	Conditions	Minimum	Maximum	Units
V_{IN}	Supply Voltage			5.5	V
T_{STOR}	Storage Temperature		0	80	°C

Operating Conditions

Table 3. Recommended Operating Conditions

Symbol	Parameter	Minimum	Typical	Maximum	Units
V_{IN}	Supply Voltage	5.0		5.5	V
T_{AMB}	Ambient Operating Temperature	5		75	°C
P_{CM}	Common-Mode Pressure			30	PSI

Electrical Characteristics

Table 4. Electrical Characteristics

Symbol	Parameter	Conditions	Minimum	Typical	Maximum	Units
I_{VIN}	Current Consumption			15		mA
FLQ	Liquid Flow Range		0		7	Liter/min
V_{OUT}	Analog Voltage Output	Uncalibrated	0		4.5	V
V_{NULL}	Flow Null Voltage		0	0.1	0.3	V
τ_H	Flow Response Time [a]			5		msec
V_{TEMP}	Temperature Output	At 5°C		4.25		V
		At 80°C		1.0		V

[a] The flow response time includes a 10% to 90% rise time for the flow sensor to electrically respond to any liquid flow change. Measurements might be affected by the pneumatic interface.

Mechanical Drawings

The module dimensional drawing is located at the end of this document. The package information is the most current data available and is subject to change without notice or revision of this document.

Ordering Information

Note: The part code depends on the application. In the part code, NG refers to “non-corrosive gas” and LQ refers to “liquid.”

Orderable Part Number	Description and Package	Shipping Packaging	Temperature
FS1025	FS1025: 0 to 7 liter/min liquid flow sensor module with amplified analog output	Box	5°C to +75°C

Revision History

Revision Date	Description of Change
December 14, 2017	Initial release.



Corporate Headquarters

6024 Silver Creek Valley Road
San Jose, CA 95138
www.IDT.com

Sales

1-800-345-7015 or 408-284-8200
Fax: 408-284-2775
www.IDT.com/go/sales

Tech Support

www.IDT.com/go/support

DISCLAIMER Integrated Device Technology, Inc. (IDT) and its affiliated companies (herein referred to as "IDT") reserve the right to modify the products and/or specifications described herein at any time, without notice, at IDT's sole discretion. Performance specifications and operating parameters of the described products are determined in an independent state and are not guaranteed to perform the same way when installed in customer products. The information contained herein is provided without representation or warranty of any kind, whether express or implied, including, but not limited to, the suitability of IDT's products for any particular purpose, an implied warranty of merchantability, or non-infringement of the intellectual property rights of others. This document is presented only as a guide and does not convey any license under intellectual property rights of IDT or any third parties.

IDT's products are not intended for use in applications involving extreme environmental conditions or in life support systems or similar devices where the failure or malfunction of an IDT product can be reasonably expected to significantly affect the health or safety of users. Anyone using an IDT product in such a manner does so at their own risk, absent an express, written agreement by IDT.

Integrated Device Technology, IDT and the IDT logo are trademarks or registered trademarks of IDT and its subsidiaries in the United States and other countries. Other trademarks used herein are the property of IDT or their respective third party owners. For datasheet type definitions and a glossary of common terms, visit www.idt.com/go/glossary. All contents of this document are copyright of Integrated Device Technology, Inc. All rights reserved.

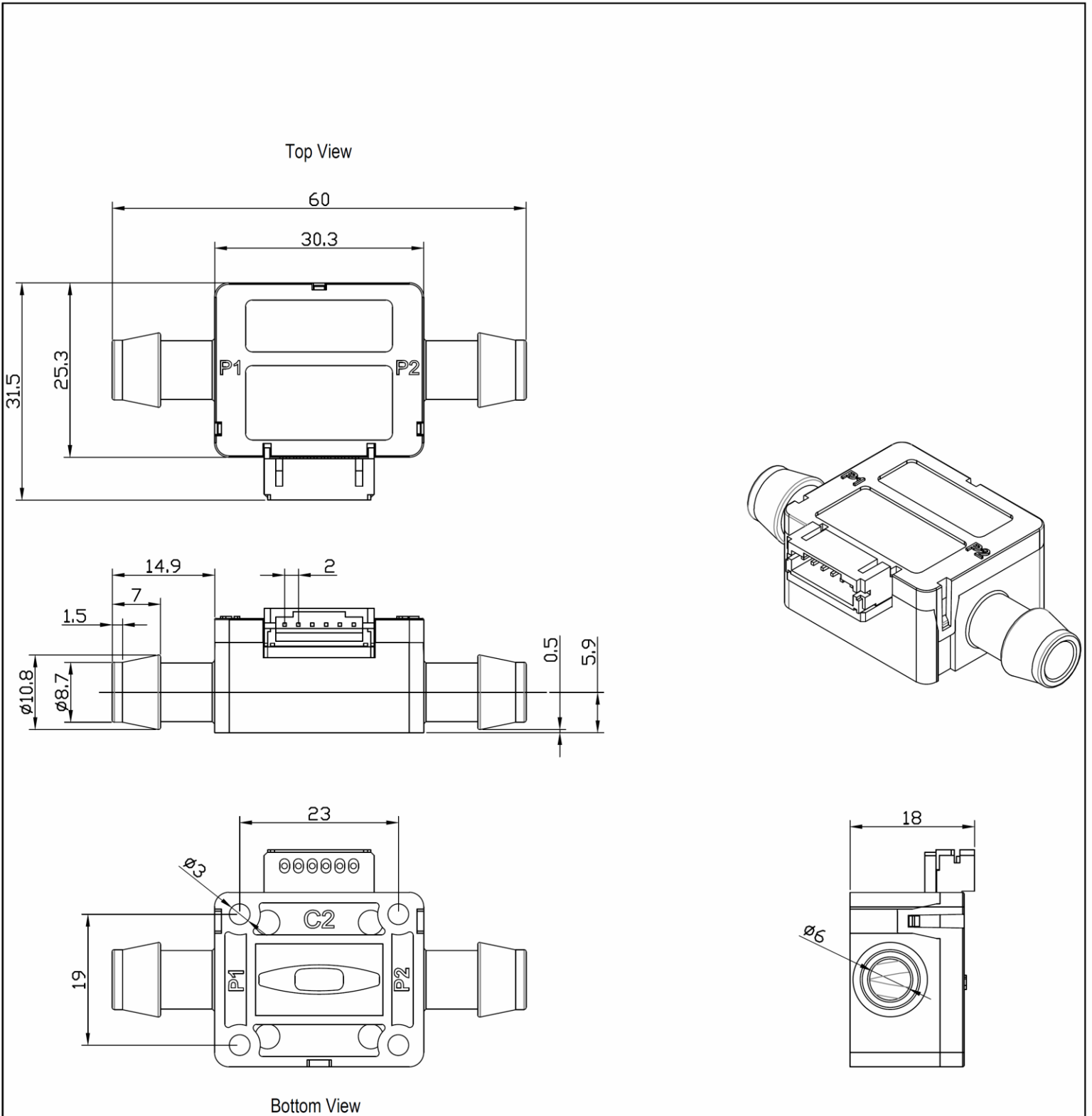

Package Revision History		
Date Created	Rev No.	Description
Nov 28, 2017	Rev 00	Initial Release