



Chipsmall Limited consists of a professional team with an average of over 10 year of expertise in the distribution of electronic components. Based in Hongkong, we have already established firm and mutual-benefit business relationships with customers from,Europe,America and south Asia,supplying obsolete and hard-to-find components to meet their specific needs.

With the principle of "Quality Parts,Customers Priority,Honest Operation,and Considerate Service",our business mainly focus on the distribution of electronic components. Line cards we deal with include Microchip,ALPS,ROHM,Xilinx,Pulse,ON,Everlight and Freescale. Main products comprise IC,Modules,Potentiometer,IC Socket,Relay,Connector.Our parts cover such applications as commercial,industrial, and automotives areas.

We are looking forward to setting up business relationship with you and hope to provide you with the best service and solution. Let us make a better world for our industry!



## Contact us

Tel: +86-755-8981 8866 Fax: +86-755-8427 6832

Email & Skype: info@chipsmall.com Web: www.chipsmall.com

Address: A1208, Overseas Decoration Building, #122 Zhenhua RD., Futian, Shenzhen, China





Is Now Part of



**ON Semiconductor®**

To learn more about ON Semiconductor, please visit our website at  
[www.onsemi.com](http://www.onsemi.com)

ON Semiconductor and the ON Semiconductor logo are trademarks of Semiconductor Components Industries, LLC dba ON Semiconductor or its subsidiaries in the United States and/or other countries. ON Semiconductor owns the rights to a number of patents, trademarks, copyrights, trade secrets, and other intellectual property. A listing of ON Semiconductor's product/patent coverage may be accessed at [www.onsemi.com/site/pdf/Patent-Marking.pdf](http://www.onsemi.com/site/pdf/Patent-Marking.pdf). ON Semiconductor reserves the right to make changes without further notice to any products herein. ON Semiconductor makes no warranty, representation or guarantee regarding the suitability of its products for any particular purpose, nor does ON Semiconductor assume any liability arising out of the application or use of any product or circuit, and specifically disclaims any and all liability, including without limitation special, consequential or incidental damages. Buyer is responsible for its products and applications using ON Semiconductor products, including compliance with all laws, regulations and safety requirements or standards, regardless of any support or applications information provided by ON Semiconductor. "Typical" parameters which may be provided in ON Semiconductor data sheets and/or specifications can and do vary in different applications and actual performance may vary over time. All operating parameters, including "Typicals" must be validated for each customer application by customer's technical experts. ON Semiconductor does not convey any license under its patent rights nor the rights of others. ON Semiconductor products are not designed, intended, or authorized for use as a critical component in life support systems or any FDA Class 3 medical devices or medical devices with a same or similar classification in a foreign jurisdiction or any devices intended for implantation in the human body. Should Buyer purchase or use ON Semiconductor products for any such unintended or unauthorized application, Buyer shall indemnify and hold ON Semiconductor and its officers, employees, subsidiaries, affiliates, and distributors harmless against all claims, costs, damages, and expenses, and reasonable attorney fees arising out of, directly or indirectly, any claim of personal injury or death associated with such unintended or unauthorized use, even if such claim alleges that ON Semiconductor was negligent regarding the design or manufacture of the part. ON Semiconductor is an Equal Opportunity/Affirmative Action Employer. This literature is subject to all applicable copyright laws and is not for resale in any manner.



# FSA3030 — High-Speed USB2.0/Mobile High-Definition Link (MHL™) with Negative Swing Audio

## Features

- Low On Capacitance: 4.2 pF/5 pF MHL/USB (Typical)
- Low Power Consumption: 30  $\mu$ A Maximum
- Supports MHL Rev. 2.0
- MHL Data Rate: 4.0 Gbps
- Audio Swing: -1.5 V to +1.5 V (Typical)
- Packaged in 12-Lead UMLP (1.8 x 1.8 mm)
- Over-Voltage Tolerance (OVT) on all USB Ports Up to 5.25 V without External Components

## Applications

- Cell Phones and Digital Cameras

## Description

The FSA3030 is a bi-directional, low-power, high-speed, 3:1, USB2.0, MHL™ and audio switch. Configured as a double-pole, triple-throw (DP3T) switch, it is optimized for switching between high- or full-speed USB, Mobile High-Definition Link sources (per MHL Rev. 2.0 specification) and negative swing capable audio.

The FSA3030 contains special circuitry on the switch I/O pins, for applications where the  $V_{CC}$  supply is powered off ( $V_{CC}=0$ ), that allows the device to withstand an over-voltage condition. This switch is designed to minimize current consumption even when the control voltage applied to the control pins is lower than the supply voltage ( $V_{CC}$ ). This is especially valuable in mobile applications, such as cell phones, allowing direct interface with the general-purpose I/Os of the baseband processor. Other applications include switching and connector sharing in portable cell phones, digital cameras, and notebook computers.

## Ordering Information

Part Number	Top Mark	Operating Temperature Range	Package
FSA3030UMX	LU	-40 to +85°C	12-Lead, Ultrathin Molded Leadless Package (UMLP), 1.8 mm x 1.8 mm

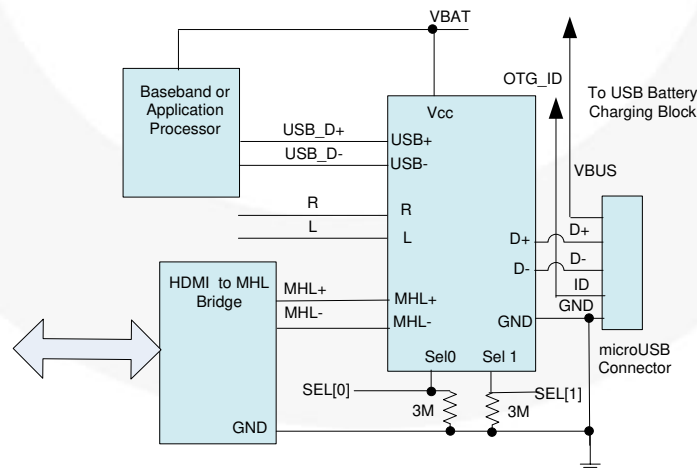


Figure 1. Typical Application

All trademarks are the property of their respective owners.

## Analog Symbol

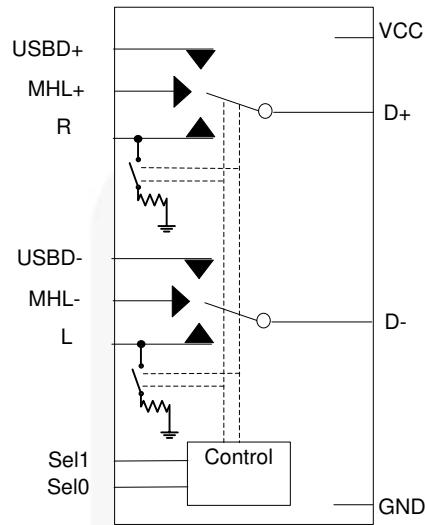


Figure 2. Analog Symbol

Table 1. Data Switch Select Truth Table

SEL1 <sup>(1)</sup>	SELO <sup>(1)</sup>	Shunt	Function
0	0	Enable	D+/D- connected to USB+/USB-
0	1	Disable	D+/D- connected to R/L
1	0	Enable	D+/D- connected to MHL+/MHL
1	1	Enable	D+/D- High Impedance

**Note:**

- Control inputs should never be left floating or unconnected. To guarantee default switch closure to the USB position, the SEL[0:1] pins should be tied to GND with a weak pull-down resistor (3 MΩ) to minimize static current draw.



## Pin Configuration

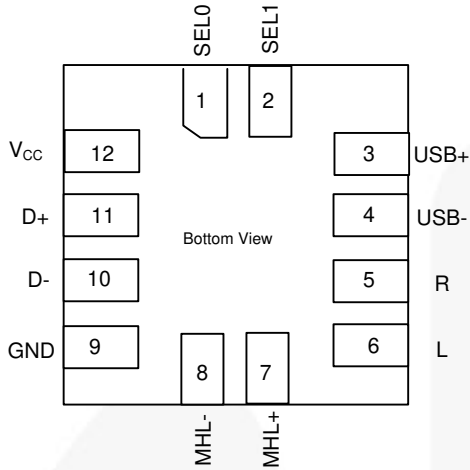


Figure 3. Pin Assignments

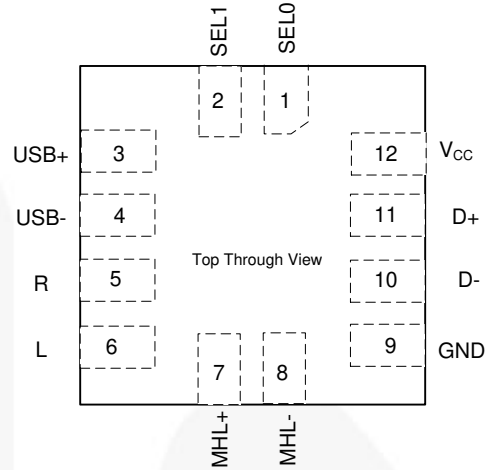


Figure 4. Top Through View

## Pin Definitions

Pin#	Name	Description
1	SEL0	Data Switch Select
2	SEL1	Data Switch Select
3	USB+	USB Differential Data (Positive)
4	USB-	USB Differential Data (Negative)
5	R	Audio Right
6	L	Audio Left
7	MHL+	MHL Differential Data (Positive)
8	MHL-	MHL Differential Data (Negative)
9	GND	Ground
10	D-	Data Switch Output (Positive)
11	D+	Data Switch Output (Negative)
12	V <sub>CC</sub>	Device Power from System

## Absolute Maximum Ratings

Stresses exceeding the absolute maximum ratings may damage the device. The device may not function or be operable above the recommended operating conditions and stressing the parts to these levels is not recommended. In addition, extended exposure to stresses above the recommended operating conditions may affect device reliability. The absolute maximum ratings are stress ratings only.

Symbol	Parameter	Min.	Max.	Unit	
V <sub>CC</sub>	Supply Voltage	-0.5	6.0	V	
V <sub>CNTRL</sub>	DC Input Voltage (SEL[1:0]) <sup>(2)</sup>	-0.5	V <sub>CC</sub>	V	
V <sub>SW</sub> <sup>(3)</sup>	DC Switch I/O Voltage <sup>(2)</sup>	USB	-0.5	V <sub>CC</sub>	V
		MHL	-0.5	V <sub>CC</sub>	
		AUDIO	-2.0	3	
I <sub>IK</sub>	DC Input Diode Current	-50		mA	
I <sub>OUT</sub>	Switch DC Output Current (Continuous)	USB		60	mA
		MHL		60	mA
		AUDIO		60	mA
I <sub>OUTPEAK</sub>	Switch DC Output Peak Current (Pulsed at 1 ms Duration, <10% Duty Cycle)	USB		150	mA
		MHL		150	mA
		AUDIO		150	mA
T <sub>STG</sub>	Storage Temperature	-65	+150	°C	
MSL	Moisture Sensitivity Level: JEDEC J-STD-020A		1		
ESD	IEC 61000-4-2, Level 4, for D+/D- and V <sub>CC</sub> Pins <sup>(4)</sup>	Contact		8	kV
	IEC 61000-4-2, Level 4, for D+/D- and V <sub>CC</sub> Pins <sup>(4)</sup>	Air		15	
	Human Body Model, JEDEC: JESD22-A114	All Pins		3.5	
	Charged Device Model, JESD22-C101			2	

### Notes:

- The input and output negative ratings may be exceeded if the input and output diode current ratings are observed.
- V<sub>SW</sub> refers to analog data switch paths (USB, MHL, and audio).
- Testing performed in a system environment using TVS diodes.

## Recommended Operating Conditions

The Recommended Operating Conditions table defines the conditions for actual device operation. Recommended operating conditions are specified to ensure optimal performance to the datasheet specifications. Fairchild does not recommend exceeding them or designing to Absolute Maximum Ratings.

Symbol	Parameter	Min.	Max.	Unit
V <sub>CC</sub>	Supply Voltage	2.5	4.5	V
t <sub>RAMP(VCC)</sub>	Power Supply Slew Rate	100	1000	μs/V
θ <sub>JA</sub>	Thermal Resistance		230	°C/W
V <sub>CNTRL</sub>	Control Input Voltage (SEL[1:0]) <sup>(5)</sup>	0	4.5	V
V <sub>SW(USB)</sub>	Switch I/O Voltage (USB Switch Path)	-0.5	3.6	V
V <sub>SW(MHL)</sub>	Switch I/O Voltage (MHL Switch Path)	1.65	3.45	V
V <sub>SW(AUD)</sub>	Switch I/O Voltage (Audio Switch Path)	-1.5	3.0	V
T <sub>A</sub>	Operating Temperature	-40	+85	°C

### Note:

- The control inputs must be held HIGH or LOW; they must not float.

## DC Electrical Characteristics

All typical value are at  $T_A=25^{\circ}\text{C}$  unless otherwise specified.

Symbol	Parameter	Condition	$V_{CC}$ (V)	$T_A=-40^{\circ}\text{C}$ to $+85^{\circ}\text{C}$			Unit
				Min.	Typ.	Max.	
$V_{IK}$	Clamp Diode Voltage	$I_{IN}=-18\text{ mA}$	2.5			-1.2	V
$V_{IH}$	Control Input Voltage High SEL[1:0]		2.5 to 4.50	1.0			V
$V_{IL}$	Control Input Voltage Low SEL[1:0]		2.5 to 4.50			0.5	V
$I_{IN}$	Control Input Leakage SEL[1:0]	$V_{SW}(\text{USB/MHL})=0$ to 3.6 V, $V_{SW}(\text{AUD})=0$ to 3.0 V, $V_{CNTRL}=0$ to $V_{CC}$	4.5	-0.5		0.5	$\mu\text{A}$
$I_{OZ(\text{MHL})}$	Off-State Leakage for Open MHL Data Paths	$V_{SW}=1.65 \leq \text{MHL} \leq 3.45\text{ V}$ SEL[1:0]= $V_{CC}$	4.5	-1		1	$\mu\text{A}$
$I_{OZ(\text{USB})}$	Off-State Leakage for Open USB Data Paths	$V_{SW}=0 \leq \text{USB} \leq 3.6\text{ V}$ SEL[1:0]= $V_{CC}$	4.5	-0.5		0.5	$\mu\text{A}$
$I_{CL(\text{MHL})}$	On-State Leakage for Closed MHL Data Paths <sup>(6)</sup>	$V_{SW}=1.65 \leq \text{MHL} \leq 3.45\text{ V}$ , SEL0=GND, SEL1= $V_{CC}$ , Other Side of Switch Float	4.5	-0.75		0.75	$\mu\text{A}$
$I_{CL(\text{USB})}$	On-State Leakage for Closed USB Data Paths <sup>(6)</sup>	$V_{SW}=0 \leq \text{USB} \leq 3.6\text{ V}$ SEL[1:0]=GND, Other Side of Switch Float	4.5	-0.75		0.75	$\mu\text{A}$
$I_{CL(\text{AUD})}$	On-State Leakage for Closed <sup>(6)</sup> AUDIO Data Path	$V_{SW}=-1.5 \leq \text{R/L} \leq 1.5\text{ V}$ SEL1=GND, SEL0= $V_{CC}$ , Other Side of Switch Float	4.5	-1.0		1.0	$\mu\text{A}$
$I_{OFF}$	Power-Off Leakage Current (All I/O Ports)	$V_{SW}(\text{USB/MHL})=0$ to 3.6 V, $V_{SW}(\text{AUD})=0$ to 3.0 V, Figure 5	0	-1		1	$\mu\text{A}$
$R_{ON(\text{USB})}$	HS Switch On Resistance (USB to D Path)	$V_{SW}=0.4\text{ V}$ , $I_{ON}=-8\text{ mA}$ , SEL[1:0]=GND, Figure 6	2.5			4.5	$\Omega$
$R_{ON(\text{MHL})}$	HS Switch On Resistance (MHL to D Path)	$V_{SW}=V_{CC}-1050\text{ mV}$ , SEL0=GND, SEL1= $V_{CC}$ $I_{ON}=-8\text{ mA}$ , Figure 6	2.5			5	$\Omega$
$R_{ON(\text{Audio})}$	Audio Switch On Resistance (R/L Path)	$V_{SW}=-1.5\text{ V}$ to 1.5 V, SEL1=GND, SEL0= $V_{CC}$ , $I_{ON}=-24\text{ mA}$ , Figure 6	2.5			4	$\Omega$
$\Delta R_{ON(\text{MHL})}$	Difference in $R_{ON}$ Between MHL Positive-Negative	$V_{SW}=V_{CC}-1050\text{ mV}$ , SEL0=GND, SEL1= $V_{CC}$ , $I_{ON}=-8\text{ mA}$ , Figure 6,	2.5			0.03	$\Omega$
$\Delta R_{ON(\text{USB})}$	Difference in $R_{ON}$ Between USB Positive-Negative	$V_{SW}=0.4\text{ V}$ , $I_{ON}=-8\text{ mA}$ , SEL[1:0]=GND, Figure 6	2.5			0.18	$\Omega$
$R_{ONF(\text{MHL})}$	Flatness for $R_{ON}$ MHL Path	$V_{SW}=1.65$ to 3.45V, SEL0=GND, SEL1= $V_{CC}$ , $I_{ON}=-8\text{ mA}$ , Figure 6	2.5			1	$\Omega$
$R_{ONFA(\text{AUDIO})}$	Flatness for $R_{ON}$ Audio Path	$V_{SW}=-1.5\text{ V}$ to 1.5 V, SEL1=GND, SEL0= $V_{CC}$ , $I_{ON}=-24\text{ mA}$ , Figure 6	2.5			0.1	$\Omega$
$R_{SH}$	Shunt Resistance		3.6			125 200	$\Omega$
$I_{CC}$	Quiescent Current	$V_{CNTRL}=0$ or 4.5 V, $I_{OUT}=0$	4.5			30	$\mu\text{A}$
$I_{CCT}$	Delta Increase in Quiescent Current per Control Pin	$V_{CNTRL}=1.65\text{ V}$ , $I_{OUT}=0$	4.5			18	$\mu\text{A}$
		$V_{CNTRL}=2.5\text{ V}$ , $I_{OUT}=0$	4.5			10	

### Note:

6. For this test, the data switch is closed with the respective switch pin floating.

## AC Electrical Characteristics

All typical values are for  $V_{CC}=3.3$  V and  $T_A=25^\circ\text{C}$  unless otherwise specified.

Symbol	Parameter	Condition	$V_{CC}$ (V)	$T_A=-40^\circ\text{C}$ to $+85^\circ\text{C}$			Unit
				Min.	Typ.	Max.	
$t_{ONUSB}$	USB Turn-On Time, SEL[1:0] to Output	$R_L=50\ \Omega$ , $C_L=5\ \text{pF}$ , $V_{SW(USB)}=0.8\ \text{V}$ , $V_{SW(MHL)}=3.3\ \text{V}$ , $V_{SW(AUD)}=1.5\ \text{V}$ , Figure 7, Figure 8	2.5 to 3.6		445	600	ns
$t_{OFFUSB}$	USB Turn-Off Time, SEL[1:0] to Output	$R_L=50\ \Omega$ , $C_L=5\ \text{pF}$ , $V_{SW(USB)}=0.8\ \text{V}$ , $V_{SW(MHL)}=3.3\ \text{V}$ , $V_{SW(AUD)}=1.5\ \text{V}$ , Figure 7, Figure 8	2.5 to 3.6		445	600	ns
$t_{ONAUD}$	AUDIO Turn-On Time, SEL[1:0] to Output	$R_L=50\ \Omega$ , $C_L=5\ \text{pF}$ , $V_{SW(USB)}=0.8\ \text{V}$ , $V_{SW(MHL)}=3.3\ \text{V}$ , $V_{SW(AUD)}=1.5\ \text{V}$ , Figure 7, Figure 8	2.5 to 3.6		445	600	ns
$t_{OFFAUD}$	AUDIO Turn-Off Time, SEL[1:0] to Output	$R_L=50\ \Omega$ , $C_L=5\ \text{pF}$ , $V_{SW(USB)}=0.8\ \text{V}$ , $V_{SW(MHL)}=3.3\ \text{V}$ , $V_{SW(AUD)}=1.5\ \text{V}$ , Figure 7, Figure 8	2.5 to 3.6		445	600	ns
$t_{ONMHL}$	MHL Turn-On Time, SEL[1:0] to Output	$R_L=50\ \Omega$ , $C_L=5\ \text{pF}$ , $V_{SW(USB)}=0.8\ \text{V}$ , $V_{SW(MHL)}=3$ , $V_{SW(AUD)}=1.5\ \text{V}$ , Figure 7, Figure 8	2.5 to 3.6		445	600	ns
$t_{OFFMHL}$	MHL Turn-Off Time, SEL[1:0] to Output	$R_L=50\ \Omega$ , $C_L=5\ \text{pF}$ , $V_{SW(USB)}=0.8\ \text{V}$ , $V_{SW(MHL)}=3.3\ \text{V}$ , $V_{SW(AUD)}=1.5\ \text{V}$ , Figure 7, Figure 8	2.5 to 3.6		445	600	ns
$t_{PD}$	Propagation Delay <sup>(7)</sup>	$C_L=5\ \text{pF}$ , $R_L=50\ \Omega$ , Figure 7, Figure 9	2.5 to 3.6		0.25		ns
$t_{BBM}$	Break-Before-Make <sup>(7)</sup>	$R_L=50\ \Omega$ , $C_L=5\ \text{pF}$ , $V_{AUD}=1.5\ \text{V}$ , $V_{MHL}=3.3\ \text{V}$ , $V_{USB}=0.8\ \text{V}$ , Figure 10	2.5 to 3.6		350		ns
$O_{IRR(MHL)}$	Off Isolation <sup>(7)</sup>	$V_S=1\ \text{V}_{pk-pk}$ , $R_L=50\ \Omega$ , $f=240\ \text{MHz}$ , Figure 11	2.5 to 3.6		-33		dB
$O_{IRR(USB)}$		$V_S=400\ \text{mV}_{pk-pk}$ , $R_L=50\ \Omega$ , $f=240\ \text{MHz}$ , Figure 11	2.5 to 3.6		-38		dB
$Xtalk_{MHL}$	Non-Adjacent Channel <sup>(7)</sup> Crosstalk	$V_S=1\ \text{V}_{pk-pk}$ , $R_L=50\ \Omega$ , $f=240\ \text{MHz}$ , Figure 12	2.5 to 3.6		-44		dB
$Xtalk_{USB}$		$V_S=400\ \text{mV}_{pk-pk}$ , $R_L=50\ \Omega$ , $f=240\ \text{MHz}$ , Figure 12	2.5 to 3.6		-39		dB
$Xtalk_{AUD}$		$V_S=100\ \text{mV}_{RMS}$ , $R_L=32\ \Omega$ , $f=20\ \text{kHz}$ , Figure 12	2.5 to 3.6		-70		dB
THD	Total Harmonic Distortion <sup>(7)</sup>	$R_T=32\ \Omega$ , $V_{SW}=2\ \text{V}_{pk-pk}$ , $f=20\ \text{Hz}$ to $20\ \text{kHz}$ , $V_{BIAS}=0\ \text{V}$	2.5		0.01		%
BW	$S_{DD21}$ Differential -3 db Bandwidth <sup>(7)</sup>	$V_{IN}=1\ \text{V}_{pk-pk}$ , Common Mode Voltage = $V_{CC} - 1.1\ \text{V}$ , MHL Path, $R_L=50\ \Omega$ , $C_L=0\ \text{pF}$ , Figure 13	2.5 to 3.6		2.0		GHz
		$V_{IN}=400\ \text{mV}_{pk-pk}$ , Common Mode Voltage = $0.2\ \text{V}$ , USB Path, $R_L=50\ \Omega$ , $C_L=0\ \text{pF}$ , Figure 13			1.80		
		AUDIO Path, $R_L=50\ \Omega$ , $C_L=0\ \text{pF}$			50		MHz

**Note:**

7. Guaranteed by characterization.



## USB High-Speed AC Electrical Characteristics

All typical value are at  $T_A=25^\circ\text{C}$  unless otherwise specified.

Symbol	Parameter	Condition	$V_{CC}$ (V)	Typ.	Unit
$t_{SK(P)}$	Skew of Opposite Transitions of the Same Output <sup>(8)</sup>	$C_L=5\text{ pF}$ , $R_L=50\ \Omega$ , Figure 14	3.0 to 3.6	3	ps
$t_J$	Total Jitter <sup>(8)</sup>	$R_L=50\ \Omega$ , $C_L=5\text{ pf}$ , $t_R=t_F=500\text{ ps}$ (10-90%) at 480 Mbps, PN7	3.0 to 3.6	15	ps

**Note:**

8. Guaranteed by characterization.

## MHL AC Electrical Characteristics

All typical value are at  $T_A=25^\circ\text{C}$  unless otherwise specified.

Symbol	Parameter	Condition	$V_{CC}$ (V)	Typ.	Unit
$t_{SK(P)}$	Skew of Opposite Transitions of the Same Output <sup>(9)</sup>	$R_{PU}=50\ \Omega$ to $V_{CC}$ , $C_L=0\text{ pF}$	3.0 to 3.6	3	ps
$t_J$	Total Jitter <sup>(9)</sup>	$f=2.25\text{ Gbps}$ , PN7, $R_{PU}=50\ \Omega$ to $V_{CC}$ , $C_L=0\text{ pF}$	3.0 to 3.6	26	ps

**Note:**

9. Guaranteed by characterization.

## Capacitance

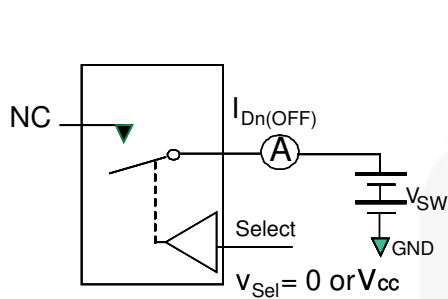
All typical value are at  $T_A=25^\circ\text{C}$  unless otherwise specified.

Symbol	Parameter	Condition	Typ.	Unit
$C_{IN}$	Control Pin Input Capacitance <sup>(10)</sup>	$V_{CC}=0\text{ V}$ , $f=1\text{ MHz}$	1.5	pF
$C_{ON(USB)}$	USB Path On Capacitance <sup>(10)</sup>	$V_{CC}=3.3\text{ V}$ , $f=240\text{ MHz}$ , Figure 15	6.5	
$C_{OFF(USB)}$	USB Path Off Capacitance <sup>(10)</sup>	$V_{CC}=3.3\text{ V}$ , $f=240\text{ MHz}$ , Figure 16	2.5	
$C_{ON(MHL)}$	MHL Path On Capacitance <sup>(10)</sup>	$V_{CC}=3.3\text{ V}$ , $f=240\text{ MHz}$ , Figure 15	6.5	
$C_{OFF(MHL)}$	MHL Path Off Capacitance <sup>(10)</sup>	$V_{CC}=3.3\text{ V}$ , $f=240\text{ MHz}$ , Figure 16	2.5	
$C_{ON(AUD)}$	Audio Path On Capacitance <sup>(10)</sup>	$V_{CC}=3.3\text{ V}$ , $f=1\text{ MHz}$ , Figure 15	8.0	
$C_{OFF(AUD)}$	Audio Path Off Capacitance <sup>(10)</sup>	$V_{CC}=3.3\text{ V}$ , $f=1\text{ MHz}$ , Figure 16	2.5	

**Note:**

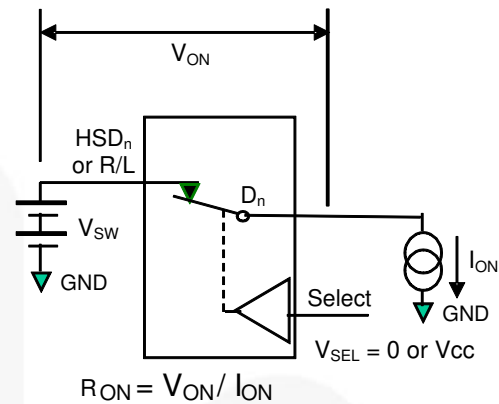
10. Guaranteed by characterization.

### Test Diagrams

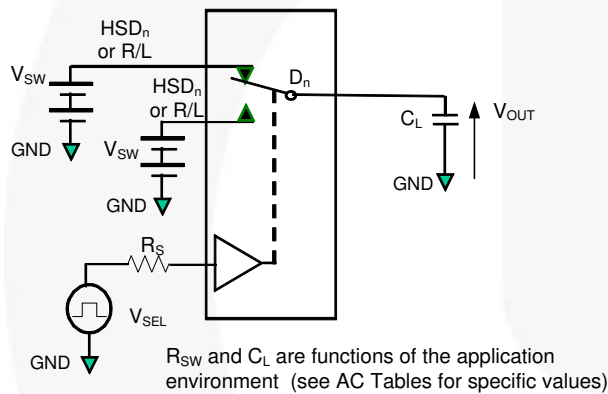


\*\*Each switch port is tested separately

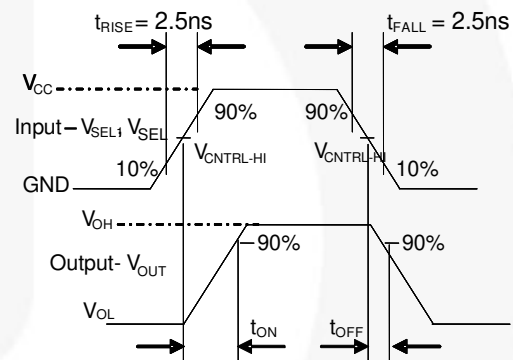
**Figure 5. Off Leakage**



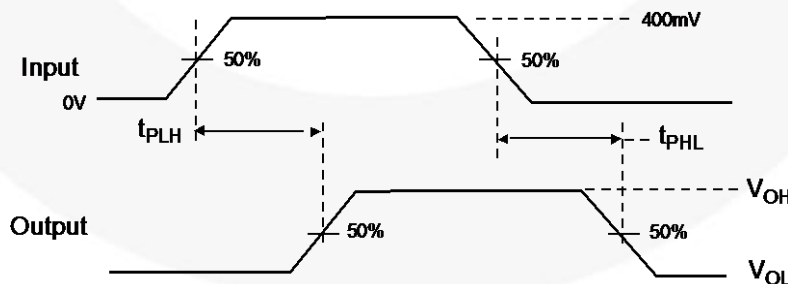
**Figure 6. On Resistance**



**Figure 7. AC Test Circuit Load**



**Figure 8. Turn-On / Turn-Off Waveforms**

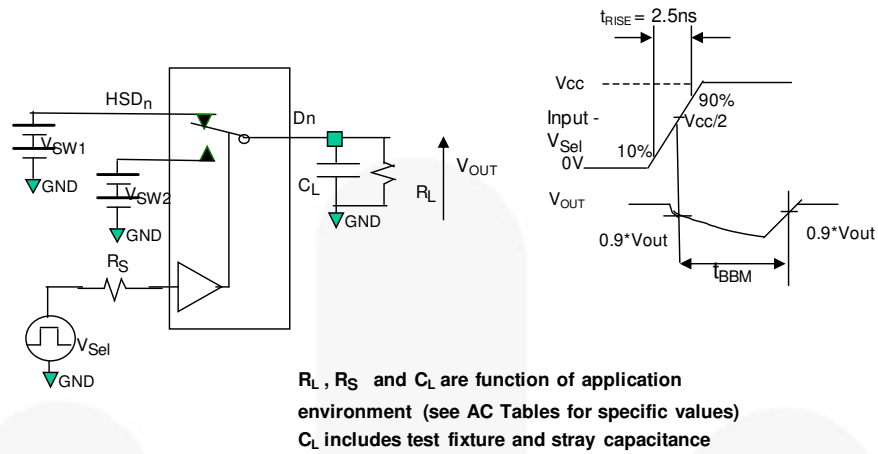


**Figure 9. Propagation Delay ( $t_{RTF} = 500ps$ )**

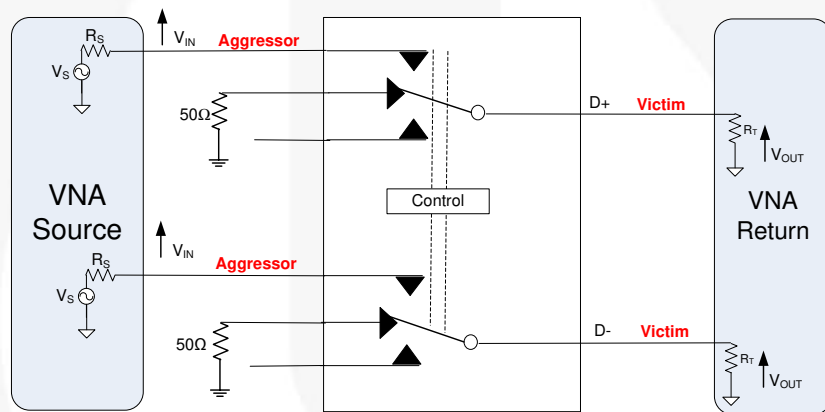
**Note:**

11. HSD<sub>n</sub> refers to the high-speed data USB or MHL paths.

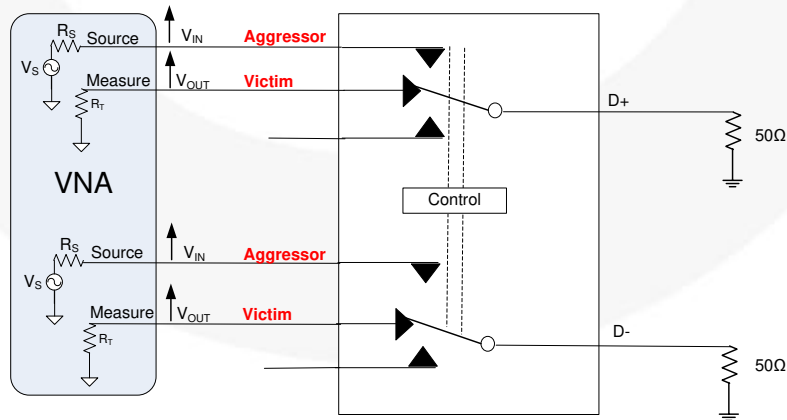
## Test Diagrams



**Figure 10. Break-Before-Make Interval Timing**

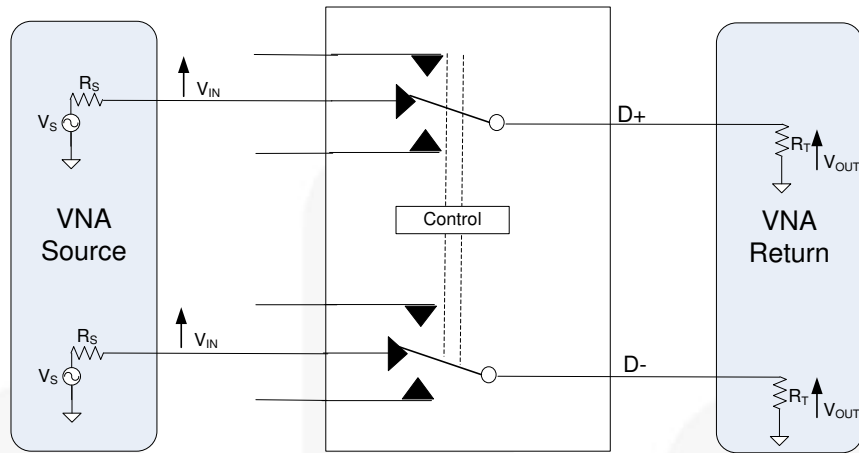


**Figure 11. Channel Off Isolation (SDD21)**



**Figure 12. Non-Adjacent Channel-to-Channel Crosstalk (SDD21)**

Test Diagrams



$V_S$ ,  $R_S$  and  $R_T$  are functions of the application environment (see AC/DC Tables for values).

Figure 13. Insertion Loss (SDD21)

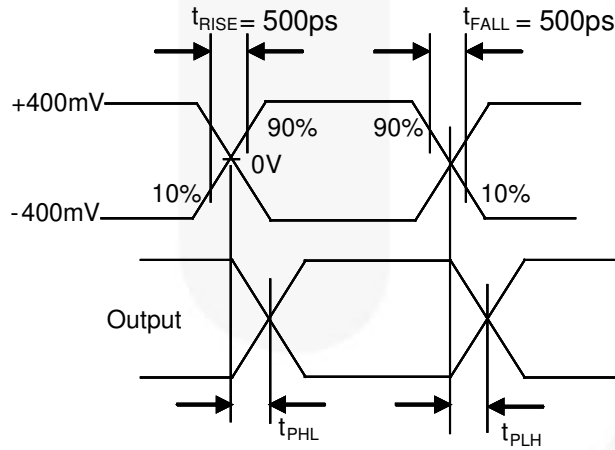


Figure 14. Intra-Pair Skew Test  $t_{SK(P)}$

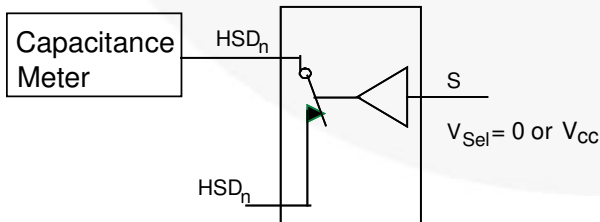


Figure 15. Channel On Capacitance

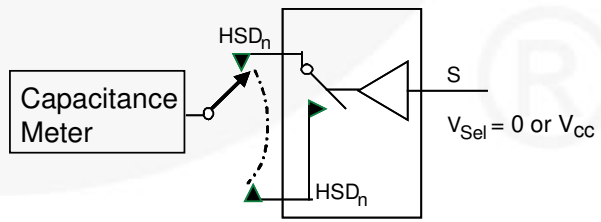


Figure 16. Channel Off Capacitance

## Functional Description

### Insertion Loss

One of the key factors for using the FSA3030 in mobile digital video applications is the small amount of insertion loss experienced by the received signal as it passes through the switch. This results in minimal degradation of the received eye. One of the ways to measure the quality of the high data rate channels is using balanced ports and four-port differential S-parameter analysis, particularly SDD21.

Bandwidth is measured using the S-parameter SDD21 methodology.



Figure 17. MHL Path SDD21 Insertion Loss Curve

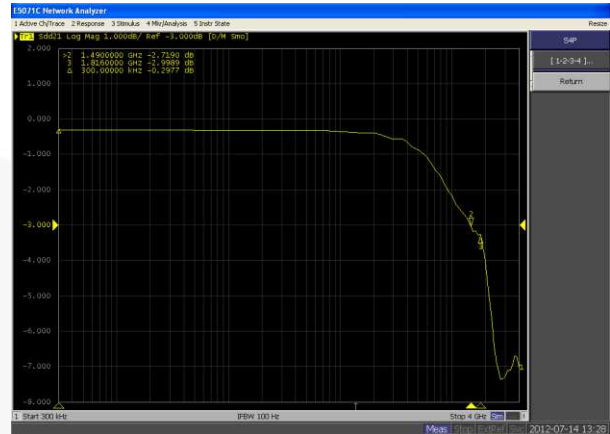


Figure 18. USB Path SDD21 Insertion Loss Curve

### Typical Applications

Figure 19 shows the FSA3030 utilizing the V<sub>BAT</sub> connection. The 3M resistors are used to ensure, for manufacturing test via the micro-USB connector, that the FSA3030 configures for connectivity to the baseband or application processor.

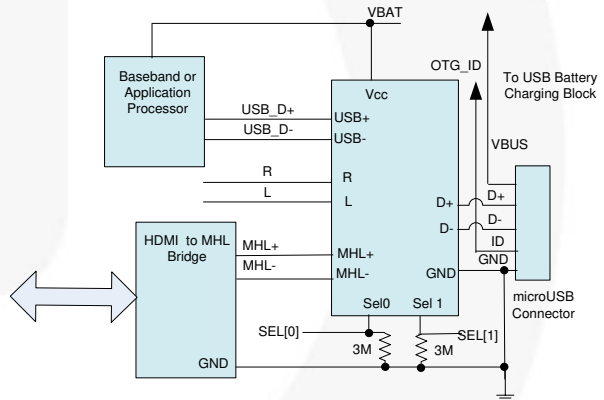
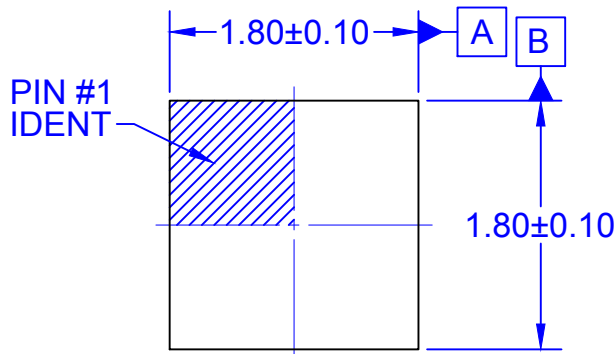


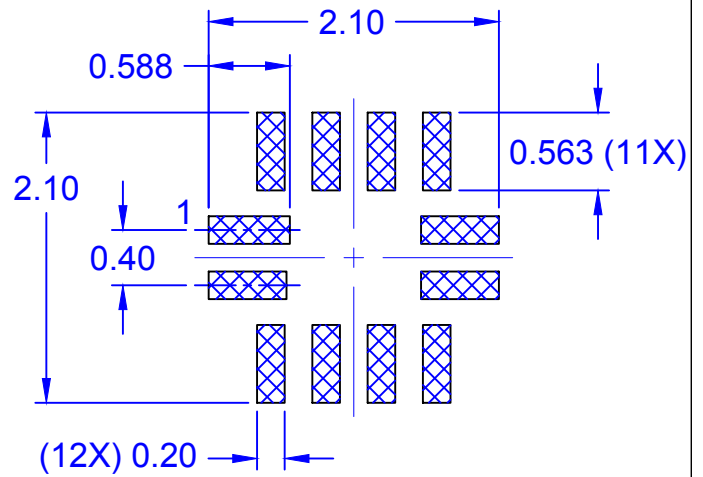
Figure 19. MHL Path SDD21 Insertion Loss Curve

Table 2. Product-Specific Package Dimensions

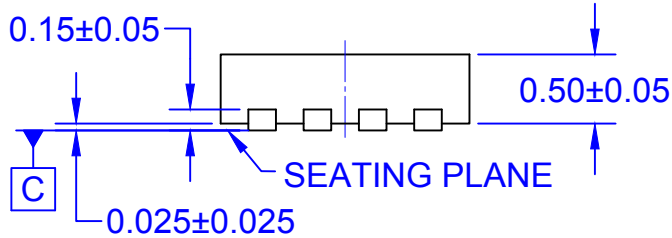
Description	Nominal Values (mm)
Overall Height	0.50
Package Standoff	0.012
Lead Thickness	0.15
Lead Width	0.20
Lead Length	0.40
Lead Pitch	0.40
Body Length (X)	Min: 1.70, Nom: 1.80, Max: 1.90
Body Width (Y)	Min: 1.70, Nom: 1.80, Max: 1.90
Lead One Nominal Length	0.40
Lead One Nominal Width	0.20
Lead One Nominal Bevel Length	0.10
Lead One Nominal Bevel Depth	0.10
Lead One Nominal Tip Non-Bevel Width	0.10



TOP VIEW



RECOMMENDED LAND PATTERN

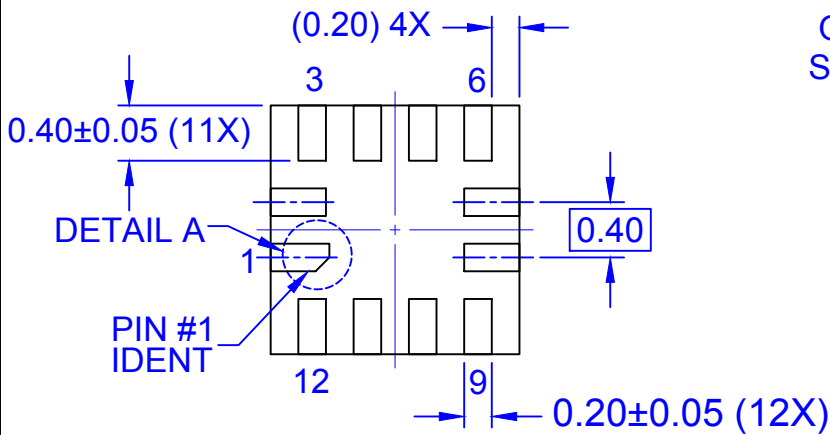


SIDE VIEW



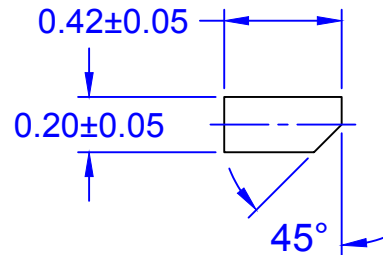
LEAD  
OPTION 1  
SCALE 2:1

LEAD  
OPTION 2  
SCALE 2:1



BOTTOM VIEW

⊕	0.10	C	A	B
	0.05	C		



DETAIL A  
SCALE 2:1

NOTES:

- A. PACKAGE DOES NOT CONFORM TO ANY JEDEC STANDARD.
- B. DIMENSIONS ARE IN MILLIMETERS.
- C. LAND PATTERN RECOMMENDATION IS EXISTING INDUSTRY LAND PATTERN.
- D. DRAWING FILENAME: MKT-UMLP12ArevF

**ON Semiconductor**





ON Semiconductor and  are trademarks of Semiconductor Components Industries, LLC dba ON Semiconductor or its subsidiaries in the United States and/or other countries. ON Semiconductor owns the rights to a number of patents, trademarks, copyrights, trade secrets, and other intellectual property. A listing of ON Semiconductor's product/patent coverage may be accessed at [www.onsemi.com/site/pdf/Patent-Marking.pdf](http://www.onsemi.com/site/pdf/Patent-Marking.pdf). ON Semiconductor reserves the right to make changes without further notice to any products herein. ON Semiconductor makes no warranty, representation or guarantee regarding the suitability of its products for any particular purpose, nor does ON Semiconductor assume any liability arising out of the application or use of any product or circuit, and specifically disclaims any and all liability, including without limitation special, consequential or incidental damages. Buyer is responsible for its products and applications using ON Semiconductor products, including compliance with all laws, regulations and safety requirements or standards, regardless of any support or applications information provided by ON Semiconductor. "Typical" parameters which may be provided in ON Semiconductor data sheets and/or specifications can and do vary in different applications and actual performance may vary over time. All operating parameters, including "Typicals" must be validated for each customer application by customer's technical experts. ON Semiconductor does not convey any license under its patent rights nor the rights of others. ON Semiconductor products are not designed, intended, or authorized for use as a critical component in life support systems or any FDA Class 3 medical devices or medical devices with a same or similar classification in a foreign jurisdiction or any devices intended for implantation in the human body. Should Buyer purchase or use ON Semiconductor products for any such unintended or unauthorized application, Buyer shall indemnify and hold ON Semiconductor and its officers, employees, subsidiaries, affiliates, and distributors harmless against all claims, costs, damages, and expenses, and reasonable attorney fees arising out of, directly or indirectly, any claim of personal injury or death associated with such unintended or unauthorized use, even if such claim alleges that ON Semiconductor was negligent regarding the design or manufacture of the part. ON Semiconductor is an Equal Opportunity/Affirmative Action Employer. This literature is subject to all applicable copyright laws and is not for resale in any manner.

## PUBLICATION ORDERING INFORMATION

### LITERATURE FULFILLMENT:

Literature Distribution Center for ON Semiconductor  
19521 E. 32nd Pkwy, Aurora, Colorado 80011 USA  
**Phone:** 303-675-2175 or 800-344-3860 Toll Free USA/Canada  
**Fax:** 303-675-2176 or 800-344-3867 Toll Free USA/Canada  
**Email:** [orderlit@onsemi.com](mailto:orderlit@onsemi.com)

**N. American Technical Support:** 800-282-9855 Toll Free  
USA/Canada  
**Europe, Middle East and Africa Technical Support:**  
Phone: 421 33 790 2910  
**Japan Customer Focus Center**  
Phone: 81-3-5817-1050

**ON Semiconductor Website:** [www.onsemi.com](http://www.onsemi.com)  
**Order Literature:** <http://www.onsemi.com/orderlit>  
For additional information, please contact your local  
Sales Representative