



Chipsmall Limited consists of a professional team with an average of over 10 year of expertise in the distribution of electronic components. Based in Hongkong, we have already established firm and mutual-benefit business relationships with customers from,Europe,America and south Asia,supplying obsolete and hard-to-find components to meet their specific needs.

With the principle of “Quality Parts,Customers Priority,Honest Operation,and Considerate Service”,our business mainly focus on the distribution of electronic components. Line cards we deal with include Microchip,ALPS,ROHM,Xilinx,Pulse,ON,Everlight and Freescale. Main products comprise IC,Modules,Potentiometer,IC Socket,Relay,Connector.Our parts cover such applications as commercial,industrial, and automotives areas.

We are looking forward to setting up business relationship with you and hope to provide you with the best service and solution. Let us make a better world for our industry!



## Contact us

Tel: +86-755-8981 8866 Fax: +86-755-8427 6832

Email & Skype: info@chipsmall.com Web: www.chipsmall.com

Address: A1208, Overseas Decoration Building, #122 Zhenhua RD., Futian, Shenzhen, China





Is Now Part of



**ON Semiconductor®**

To learn more about ON Semiconductor, please visit our website at  
[www.onsemi.com](http://www.onsemi.com)

Please note: As part of the Fairchild Semiconductor integration, some of the Fairchild orderable part numbers will need to change in order to meet ON Semiconductor's system requirements. Since the ON Semiconductor product management systems do not have the ability to manage part nomenclature that utilizes an underscore (\_), the underscore (\_) in the Fairchild part numbers will be changed to a dash (-). This document may contain device numbers with an underscore (\_). Please check the ON Semiconductor website to verify the updated device numbers. The most current and up-to-date ordering information can be found at [www.onsemi.com](http://www.onsemi.com). Please email any questions regarding the system integration to [Fairchild\\_questions@onsemi.com](mailto:Fairchild_questions@onsemi.com).

ON Semiconductor and the ON Semiconductor logo are trademarks of Semiconductor Components Industries, LLC dba ON Semiconductor or its subsidiaries in the United States and/or other countries. ON Semiconductor owns the rights to a number of patents, trademarks, copyrights, trade secrets, and other intellectual property. A listing of ON Semiconductor's product/patent coverage may be accessed at [www.onsemi.com/site/pdf/Patent-Marking.pdf](http://www.onsemi.com/site/pdf/Patent-Marking.pdf). ON Semiconductor reserves the right to make changes without further notice to any products herein. ON Semiconductor makes no warranty, representation or guarantee regarding the suitability of its products for any particular purpose, nor does ON Semiconductor assume any liability arising out of the application or use of any product or circuit, and specifically disclaims any and all liability, including without limitation special, consequential or incidental damages. Buyer is responsible for its products and applications using ON Semiconductor products, including compliance with all laws, regulations and safety requirements or standards, regardless of any support or applications information provided by ON Semiconductor. "Typical" parameters which may be provided in ON Semiconductor data sheets and/or specifications can and do vary in different applications and actual performance may vary over time. All operating parameters, including "Typicals" must be validated for each customer application by customer's technical experts. ON Semiconductor does not convey any license under its patent rights nor the rights of others. ON Semiconductor products are not designed, intended, or authorized for use as a critical component in life support systems or any FDA Class 3 medical devices or medical devices with a same or similar classification in a foreign jurisdiction or any devices intended for implantation in the human body. Should Buyer purchase or use ON Semiconductor products for any such unintended or unauthorized application, Buyer shall indemnify and hold ON Semiconductor and its officers, employees, subsidiaries, affiliates, and distributors harmless against all claims, costs, damages, and expenses, and reasonable attorney fees arising out of, directly or indirectly, any claim of personal injury or death associated with such unintended or unauthorized use, even if such claim alleges that ON Semiconductor was negligent regarding the design or manufacture of the part. ON Semiconductor is an Equal Opportunity/Affirmative Action Employer. This literature is subject to all applicable copyright laws and is not for resale in any manner.



# FSA3341 — High-Speed 4:1 USB2.0 / MHL™ Switch

## Features

- Low On Capacitance: 4.2 pF / 5 pF MHL / USB (Typical)
- Low Power Consumption: 30  $\mu$ A Maximum
- Supports MHL Rev. 2.0
- Three USB2.0 Paths
- MHL Data Rate: 4.0 Gbps
- Packaged in 16-Lead UMLP (1.8 x 2.6 mm)
- Over-Voltage Tolerance on All USB Ports: Up to 5.25 V without External Components

## Applications

- Cell Phones and Digital Cameras

## Description

The FSA3341 is a bi-directional, low-power, high-speed, 4:1, USB2.0 and MHL™ switch. Configured as a Double-Pole, Four-Throw (DP4T) switch; it is optimized for switching between high- or full-speed USB and Mobile High-Definition Link sources (MHL Rev. 2.0 specification). In addition, the USB2.0 paths can be used as UART paths.

The FSA3341 contains circuitry on the switch I/O pins that allows the device to withstand an over-voltage condition for applications where the  $V_{CC}$  supply is powered off ( $V_{CC} = 0$  V). This switch is designed to minimize current consumption even when the control voltage applied to the control pins is lower than the supply voltage ( $V_{CC}$ ). This is especially valuable in mobile applications, such as cell phones, allowing direct interface with the general-purpose I/Os of the baseband processor. Other applications include circuit switching and connector sharing in portable cell phones, digital cameras, and notebook computers.

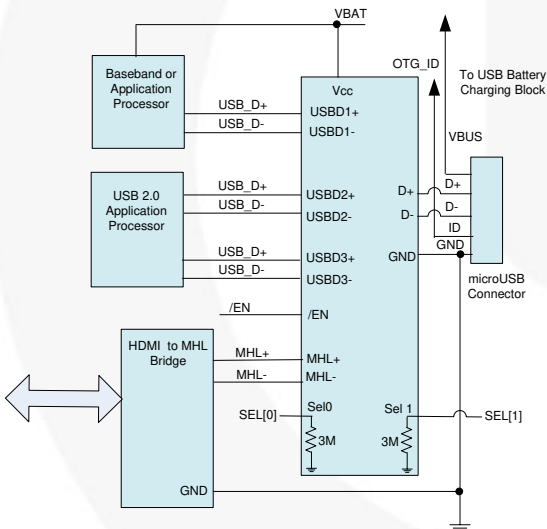


Figure 1. Typical Application

## Ordering Information

Part Number	Top Mark	Operating Temperature Range	Package
FSA3341UMX	LY	-40 to +85°C	16-Lead, Ultrathin Molded Leadless Package (UMLP), 1.8 mm x 2.6 mm

All trademarks are the property of their respective owners.

## Pin Configuration

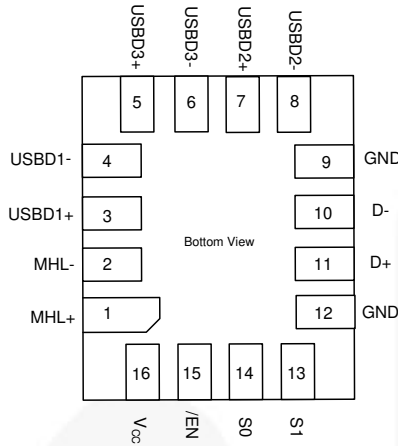


Figure 2. Pin Assignments

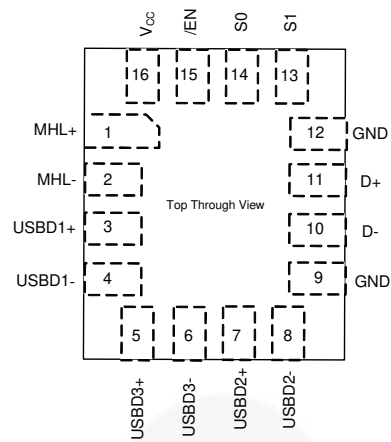


Figure 3. Top Through View

## Pin Definitions

Pin#	Name	Description
1	MHL+	MHL Differential Data (Positive)
2	MHL-	MHL Differential Data (Negative)
3	USB1D+	USB Differential Data (Positive); also can be used as additional UART
4	USB1D-	USB Differential Data (Negative); also can be used as additional UART
5	USB3D+	USB Differential Data (Positive); also can be used as additional UART
6	USB3D-	USB Differential Data (Negative); also can be used as additional UART
7	USB2D+	USB Differential Data (Positive); can be used as a UART port (see Figure 1)
8	USB2D-	USB Differential Data (Negative); can be used as a UART port (see Figure 1)
9	GND	Ground
10	D-	USB Differential Data (Negative), Common Port
11	D+	USB Differential Data (Positive), Common Port
12	GND	Ground
13	S1	Data Switch Select (see Table 1)
14	S0	Data Switch Select (see Table 1)
15	/EN	Enable Pin - Active LOW
16	V <sub>CC</sub>	Device Power from System (Typically V <sub>BAT</sub> )

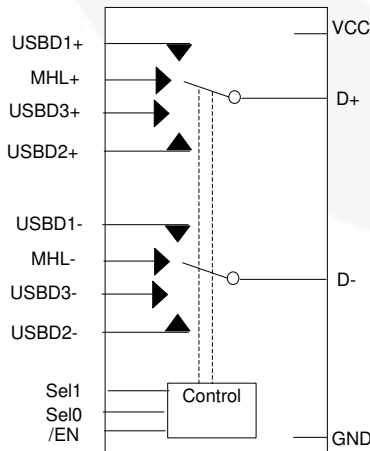


Figure 4. Analog Symbol

Table 1. Data Switch Select Truth Table

SEL1 <sup>(1)</sup>	SEL0 <sup>(1)</sup>	/EN <sup>(1)</sup>	Function
0	0	0	D+/D- connected to USB1D+/ USB1D- (or UART) path
0	1	0	D+/D- connected to USB2D+/ USB2D- (or UART) path
1	0	0	D+/D- connected to MHL+/ MHL- path
1	1	0	D+/D- connected to USB3D+/ USB3D- (or UART) path
X	X	1	D+/D- high impedance

**Note:**

- Control inputs should never be left floating or unconnected. To guarantee default switch closure to the USB position, the SEL[0:1] pins are tied to GND with internal weak pull-down resistors (3 MΩ) to minimize static current draw.

## Absolute Maximum Ratings

Stresses exceeding the absolute maximum ratings may damage the device. The device may not function or be operable above the recommended operating conditions and stressing the parts to these levels is not recommended. In addition, extended exposure to stresses above the recommended operating conditions may affect device reliability. The absolute maximum ratings are stress ratings only.

Symbol	Parameter	Min.	Max.	Unit
V <sub>CC</sub>	Supply Voltage	-0.5	5.5	V
V <sub>CNTRL</sub>	DC Input Voltage (/EN, SEL[1:0]) <sup>(2)</sup>	-0.5	V <sub>CC</sub>	V
V <sub>SW</sub> <sup>(3)</sup>	DC Switch I/O Voltage <sup>(2)</sup>			
	USB, MHL	-0.5	V <sub>CC</sub>	V
I <sub>IK</sub>	DC Input Diode Current	-50		mA
I <sub>OUT</sub>	Switch DC Output Current (Continuous)		60	mA
	USB, MHL			
I <sub>OUTPEAK</sub>	Switch DC Output Peak Current (Pulsed at 1 ms Duration, <10% Duty Cycle)		150	mA
	USB, MHL			
T <sub>STG</sub>	Storage Temperature	-65	+150	°C
MSL	Moisture Sensitivity Level: JEDEC J-STD-020A		1	
ESD	Human Body Model, JEDEC: JESD22-A114	All Pins	4	kV
	IEC 61000-4-2, Level 4, for D+/D- and V <sub>CC</sub> Pins <sup>(4)</sup>	Contact	8	
	IEC 61000-4-2, Level 4, for D+/D- and V <sub>CC</sub> Pins <sup>(4)</sup>	Air	15	
	Charged Device Model, JESD22-C101		2	

### Notes:

- The input and output negative ratings may be exceeded if the input and output diode current ratings are observed.
- V<sub>SW</sub> refers to analog data switch paths (USB, MHL, and audio).
- Testing performed in a system environment using TVS diodes.

## Recommended Operating Conditions

The Recommended Operating Conditions table defines the conditions for actual device operation. Recommended operating conditions are specified to ensure optimal performance to the datasheet specifications. Fairchild does not recommend exceeding them or designing to Absolute Maximum Ratings.

Symbol	Parameter	Min.	Max.	Unit
V <sub>CC</sub>	Supply Voltage	2.5	4.5	V
t <sub>RAMP(VCC)</sub>	Power Supply Slew Rate	100	1000	µs/V
V <sub>CNTRL</sub>	Control Input Voltage (/EN, SEL[1:0]) <sup>(5)</sup>	0	4.5	V
V <sub>SW(USB)</sub>	Switch I/O Voltage (USB Switch Path)	-0.5	3.6	V
Θ <sub>JA</sub>	Thermal Resistance		273	C°/W
V <sub>SW(MHL)</sub>	Switch I/O Voltage (MHL Switch Path)	1.65	3.45	V
T <sub>A</sub>	Operating Temperature	-40	+85	°C

### Note:

- The control inputs must be held HIGH or LOW; they must not float.

## DC Electrical Characteristics

All typical values are at  $T_A = 25^\circ\text{C}$  unless otherwise specified.

Symbol	Parameter	Condition	V <sub>CC</sub> (V)	T <sub>A</sub> =-40°C to +85°C			Unit
				Min.	Typ.	Max.	
V <sub>IK</sub>	Clamp Diode Voltage	I <sub>IN</sub> =-18 mA	2.5			-1.2	V
V <sub>IH</sub>	Control Input Voltage HIGH	SEL[1:0]	2.5	1.3			V
			3.6	1.4			V
			4.5	1.5			V
V <sub>IL</sub>	Control Input Voltage LOW	SEL[1:0]	2.5			0.4	V
			3.6			0.4	V
			4.5			0.4	V
I <sub>IN</sub>	Control Input Leakage SEL[1:0]	V <sub>SW</sub> (MHL & USB)=0 to 3.6 V, V <sub>CNTRL</sub> =0 to V <sub>CC</sub>	4.5	-2.5		2.5	μA
I <sub>OZ(MHL)</sub>	Off-State Leakage for Open MHL Data Paths	V <sub>SW</sub> =1.65 ≤ MHL ≤ 3.45 V, /EN=V <sub>CC</sub> , Figure 6	4.5	-0.5		0.5	μA
I <sub>OZ(USB)</sub>	Off-State Leakage for Open USB Data Paths	V <sub>SW</sub> =0 ≤ USB ≤ 3.6 V, /EN=V <sub>CC</sub> , Figure 6	4.5	-0.5		0.5	μA
I <sub>CL(MHL)</sub>	On-State Leakage for Closed MHL Data Paths <sup>(6)</sup>	V <sub>SW</sub> =1.65 ≤ MHL ≤ 3.45 V, /EN=GND, SEL0=GND, SEL1=V <sub>CC</sub>	4.5	-0.5		0.5	μA
I <sub>CL(USB)</sub>	On-State Leakage for Closed USB Data Paths <sup>(6)</sup>	V <sub>SW</sub> =0 ≤ USB ≤ 3.6 V, /EN=GND, SEL[1:0]=GND and SEL1=GND, SEL0=V <sub>CC</sub>	4.5	-0.5		0.5	μA
I <sub>OFF</sub>	Power-Off Leakage Current (USB & MHL Paths)	V <sub>SW</sub> =0 V or 3.6 V, Figure 6	0	-0.5		0.5	μA
R <sub>ON(USB)</sub>	HS Switch On Resistance (USB <sub>Dn</sub> to D <sub>n</sub> Path)	V <sub>SW</sub> =0.4 V, I <sub>ON</sub> =-8 mA, SEL[1:0]=GND, and SEL1=GND, SEL0=V <sub>CC</sub> Figure 5	2.5 to 4.5		8		Ω
R <sub>ON(MHL)</sub>	HS Switch On Resistance (MHL to D Path)	V <sub>SW</sub> =V <sub>CC</sub> -1050 mV, SEL0=GND, SEL1=V <sub>CC</sub> , I <sub>ON</sub> =-8 mA, Figure 5	2.5 to 4.5		5		Ω
ΔR <sub>ON(MHL)</sub>	Difference in R <sub>ON</sub> Between MHL Positive-Negative	V <sub>SW</sub> =V <sub>CC</sub> -1050 mV, SEL0=GND, SEL1=V <sub>CC</sub> , I <sub>ON</sub> =-8 mA, Figure 5,	2.5 to 4.5		0.03		Ω
ΔR <sub>ON(USB)</sub>	Difference in R <sub>ON</sub> Between USB Positive-Negative	V <sub>SW</sub> =0.4V, I <sub>ON</sub> =-8 mA, SEL[1:0]=GND and SEL1=GND, SEL0=V <sub>CC</sub> , Figure 5	2.5 to 4.5		0.18		Ω
R <sub>ONF(MHL)</sub>	Flatness for R <sub>ON</sub> MHL Path	V <sub>SW</sub> =1.65 V to 3.45 V, SEL0=GND, SEL1=V <sub>CC</sub> , I <sub>ON</sub> =-8 mA, Figure 5	2.5 to 4.5		1		Ω
R <sub>ONFD(USB)</sub>	Flatness for R <sub>ON</sub> USB Path	V <sub>SW</sub> =0 V to 3.6 V, SEL[1:0]=GND and SEL1=GND, SEL0=V <sub>CC</sub> , I <sub>ON</sub> =-8 mA, Figure 5	2.5 to 4.5		2.1		Ω
R <sub>PD</sub>	Internal Pull -Down Resistors on SEL0 & SEL1		2.5 to 4.5		3		MΩ
I <sub>CC</sub>	Quiescent Current	V <sub>CNTRL</sub> =0 or 4.5 V, I <sub>OUT</sub> =0	4.5			30	μA
I <sub>CCZ</sub>	Quiescent Current-High Impedance	V <sub>/EN</sub> =4.5 V, I <sub>OUT</sub> =0	4.5			1	μA
I <sub>CCCT</sub>	Delta Increase in Quiescent Current per Control Pin	V <sub>CNTRL</sub> =1.65 V, I <sub>OUT</sub> =0	4.5			10	μA
		V <sub>CNTRL</sub> =2.5 V, I <sub>OUT</sub> =0	4.5			5	

**Note:**

6. For this test, the data switch is closed with the respective switch pin floating.

## AC Electrical Characteristics

All typical values are for  $V_{CC} = 3.3\text{ V}$  and  $T_A = 25^\circ\text{C}$  unless otherwise specified.

Symbol	Parameter	Condition	$V_{CC}$ (V)	$T_A = -40^\circ\text{C}$ to $+85^\circ\text{C}$			Unit
				Min.	Typ.	Max.	
$t_{ONUSB}$	USB Turn-On Time, SEL[1:0] to Output	$R_L=50\ \Omega$ , $C_L=5\ \text{pF}$ , $V_{SW(USB)}=0.8\ \text{V}$ , $V_{SW(MHL)}=3.3\ \text{V}$ , Figure 7, Figure 8	2.5 to 4.5		445	700	ns
$t_{OFFUSB}$	USB Turn-Off Time, SEL[1:0] to Output	$R_L=50\ \Omega$ , $C_L=5\ \text{pF}$ , $V_{SW(USB)}=0.8\ \text{V}$ , $V_{SW(MHL)}=3.3\ \text{V}$ , Figure 7, Figure 8	2.5 to 4.5		445	600	ns
$t_{ONMHL}$	MHL Turn-On Time, SEL[1:0] to Output	$R_L=50\ \Omega$ to $3.3\ \text{V}$ , $C_L=5\ \text{pF}$ , $V_{SW(USB)}=0.8\ \text{V}$ , $V_{SW(MHL)}=3.3\ \text{V}$ , Figure 7, Figure 8	2.5 to 4.5		445	600	ns
$t_{OFFMHL}$	MHL Turn-Off Time, SEL[1:0] to Output	$R_L=50\ \Omega$ to $3.3\ \text{V}$ , $C_L=5\ \text{pF}$ , $V_{SW(USB)}=0.8\ \text{V}$ , $V_{SW(MHL)}=3.3\ \text{V}$ , Figure 7, Figure 8	2.5 to 4.5		445	600	ns
$t_{ENABLE}$	Enable Turn-On Time, /EN to Output	$R_L=50\ \Omega$ , $C_L=5\ \text{pF}$ , $V_{SW(USB)}=0.8\ \text{V}$ , $V_{SW(MHL)}=3.3\ \text{V}$ , Figure 7, Figure 8	2.5 to 4.5		80		$\mu\text{s}$
$t_{DISABLE}$	Disable Turn-Off Time, /EN to Output	$R_L=50\ \Omega$ , $C_L=5\ \text{pF}$ , $V_{SW(USB)}=0.8\ \text{V}$ , $V_{SW(MHL)}=3.3\ \text{V}$ , Figure 7, Figure 8	2.5 to 4.5		35		ns
$t_{PD}$	Propagation Delay <sup>(7)</sup>	$C_L=5\ \text{pF}$ , $R_L=50\ \Omega$ , Figure 7, Figure 9	2.5 to 4.5		0.25		ns
$t_{BBM}$	Break-Before-Make <sup>(7)</sup>	$R_L=50\ \Omega$ , $C_L=50\ \text{pF}$ , $V_{MHL}=3.3\ \text{V}$ , $V_{USB}=0.8\ \text{V}$ , Figure 11	2.5 to 4.5	50	120	600	ns
$O_{IRR(MHL)}$	Off Isolation <sup>(7)</sup>	$V_S=1\ \text{V}_{pk-pk}$ , $R_L=50\ \Omega$ , $f=24\ \text{MHz}$ , Figure 13	2.5 to 4.5		-36		dB
$O_{IRR(USB)}$		$V_S=400\ \text{mV}_{pk-pk}$ , $R_L=50\ \Omega$ , $f=240\ \text{MHz}$ , Figure 13	2.5 to 4.5		-38		dB
$O_{IRR(UART)}$		$V_S=40\ \text{mV}_{pk-pk}$ , $R_L=50\ \Omega$ , $f=10\ \text{MHz}$ , Figure 13	2.5 to 4.5		-40		dB
$Xtalk_{MHL}$	Non-Adjacent Channel Crosstalk <sup>(7)</sup>	$V_S=1\ \text{V}_{pk-pk}$ , $R_L=50\ \Omega$ , $f=240\ \text{MHz}$ , Figure 14	2.5 to 4.5		-44		dB
$Xtalk_{USB}$		$V_S=400\ \text{mV}_{pk-pk}$ , $R_L=50\ \Omega$ , $f=240\ \text{MHz}$ , Figure 14	2.5 to 4.5		-36		dB
$Xtalk_{UART}$		$V_S=400\ \text{mV}_{pk-pk}$ , $R_L=50\ \Omega$ , $f=10\ \text{MHz}$ , Figure 14	2.5 to 4.5		-36		dB
THD	Total Harmonic Distortion - LINOUT <sup>(7)</sup>	$R_T=600\ \Omega$ , $V_{SW}=2\ \text{V}_{pk-pk}$ , $f=20\ \text{Hz}$ to $20\ \text{kHz}$ , $V_{BIAS}=0\ \text{V}$	2.5 to 4.5		0.01		%
BW	$S_{DD21}$ Differential -3db Bandwidth <sup>(7)</sup>	$V_{IN}=1\ \text{V}_{pk-pk}$ , Common Mode Voltage= $V_{CC} - 1.1\ \text{V}$ , MHL Path, $R_L=50\ \Omega$ , $C_L=0\ \text{pF}$ , Figure 12	2.5 to 4.5		2.0		GHz
		$V_{IN}=400\ \text{mV}_{pk-pk}$ , Common Mode Voltage= $0.2\ \text{V}$ , USB Path, $R_L=50\ \Omega$ , $C_L=0\ \text{pF}$ , Figure 12			650 <sup>(8)</sup>		MHz

### Note:

- Guaranteed by characterization.
- 650 MHz USB Bandwidth, passed USB2.0-Compliant testing.

## USB High-Speed AC Electrical Characteristics

Typical values are at  $T_A=25^{\circ}\text{C}$  and  $V_{CC}=3.0$  to  $3.6$  V.

Symbol	Parameter	Condition	Typ.	Unit
$t_{SK(P)}$	Skew of Opposite Transitions of the Same Output <sup>(9)</sup>	$C_L=5$ pF, $R_L=50$ $\Omega$ , Figure 10	3	ps
$t_J$	Total Jitter <sup>(9)</sup>	$R_L=50$ $\Omega$ , $C_L=5$ pF, $t_R=t_F=500$ ps (10-90%) at 480 Mbps, PN7	20	ps

**Note:**

9. Guaranteed by characterization.

## MHL™ AC Electrical Characteristics

Typical values are at  $T_A=25^{\circ}\text{C}$  and  $V_{CC}=3.0$  to  $3.6$  V.

Symbol	Parameter	Condition	Typ.	Unit
$t_{SK(P)}$	Skew of Opposite Transitions of the Same Output <sup>(10)</sup>	$R_{PU}=50$ $\Omega$ to $V_{CC}$ , $C_L=0$ pF	2	ps
$t_J$	Total Jitter <sup>(10)</sup>	$f=2.25$ Gbps, PN7, $R_{PU}=50$ $\Omega$ to $V_{CC}$ , $C_L=0$ pF	15	ps

**Note:**

10. Guaranteed by characterization.

## Capacitance

Typical values are at  $T_A = 25^{\circ}\text{C}$ .

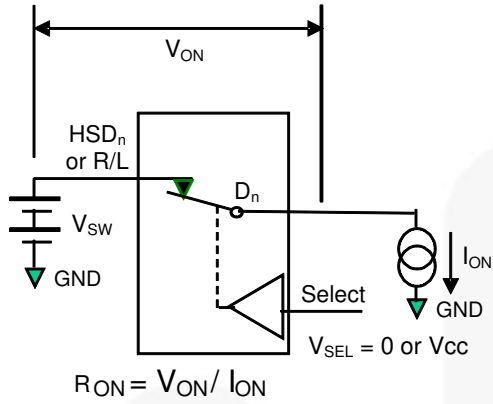
Symbol	Parameter	Condition	Typ.	Unit
$C_{IN}$	Control Pin Input Capacitance <sup>(11)</sup>	$V_{CC}=0\text{V}$ , $f=1$ MHz	2.5	pF
$C_{ON(USB)}$	USB Path On Capacitance <sup>(11)</sup>	$V_{CC}=3.3$ V, $f=240$ MHz, Figure 16	5.0	
$C_{OFF(USB)}$	USB Path Off Capacitance <sup>(11)</sup>	$V_{CC}=3.3$ V, $f=240$ MHz, Figure 15	2.5	
$C_{ON(MHL)}$	MHL Path On Capacitance <sup>(11)</sup>	$V_{CC}=3.3$ V, $f=240$ MHz, Figure 16	4.2	
$C_{OFF(MHL)}$	MHL Path Off Capacitance <sup>(11)</sup>	$V_{CC}=3.3$ V, $f=240$ MHz, Figure 15	2.5	

**Note:**

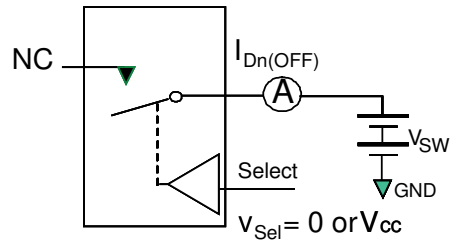
11. Guaranteed by characterization.



**Test Diagrams**

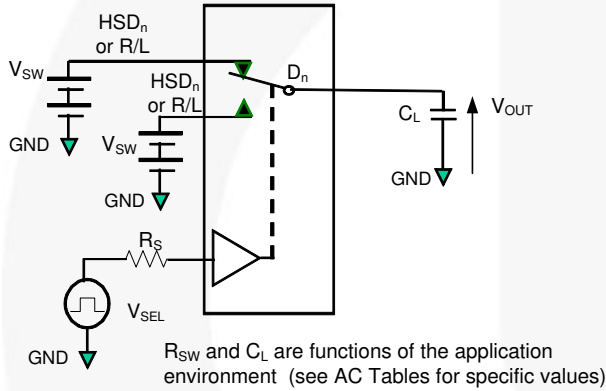


**Figure 5. On Resistance**

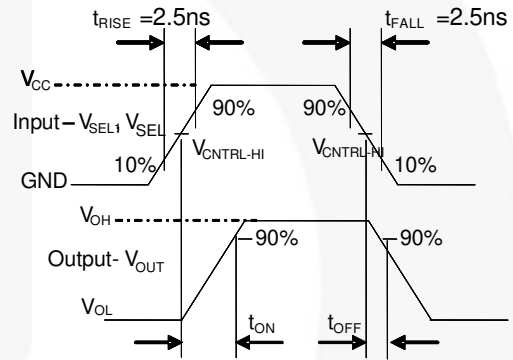


\*\*Each switch port is tested separately

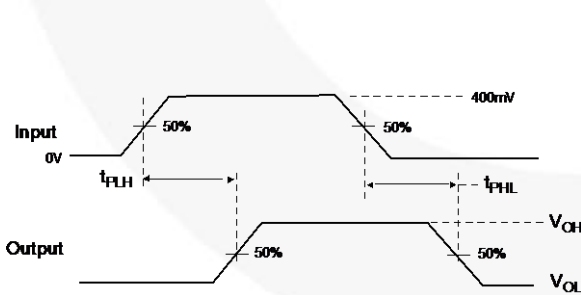
**Figure 6. Off Leakage**



**Figure 7. AC Test Circuit Load**



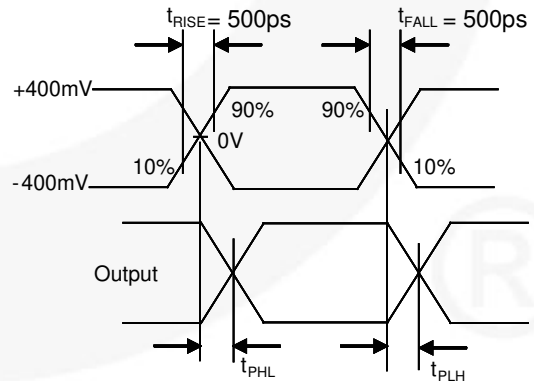
**Figure 8. Turn-On / Turn-Off Waveforms**



**Figure 9. Propagation Delay ( $t_{rF} = 500$  ps)**

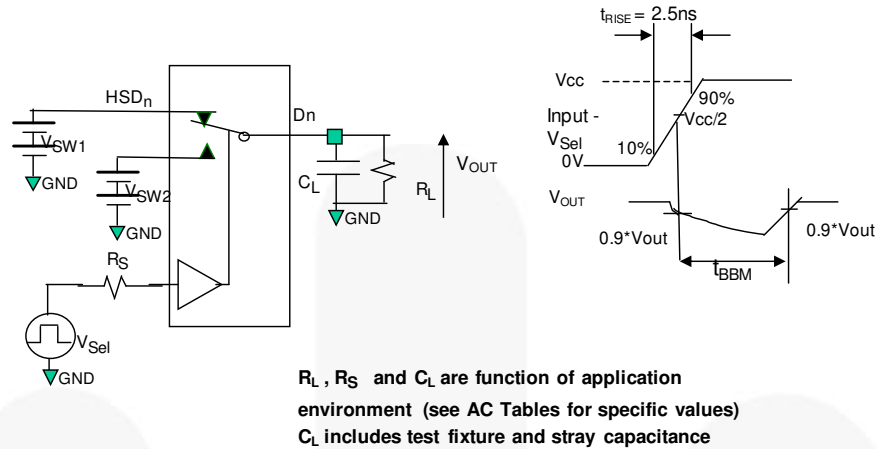
**Note:**

12. HSD<sub>n</sub> refers to the high-speed data USB or MHL paths.

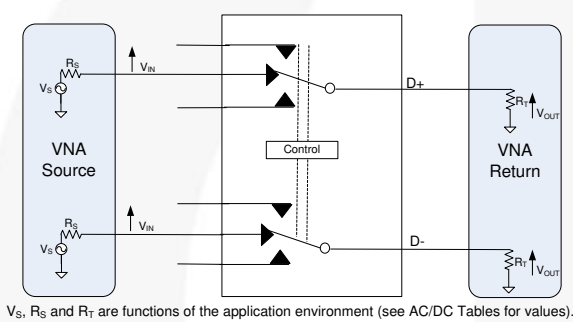


**Figure 10. Intra-Pair Skew Test  $t_{SK(P)}$**

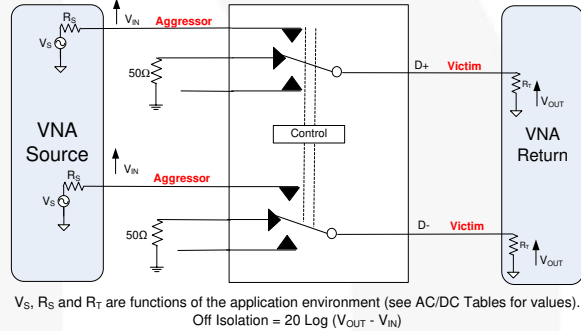
**Test Diagrams (Continued)**



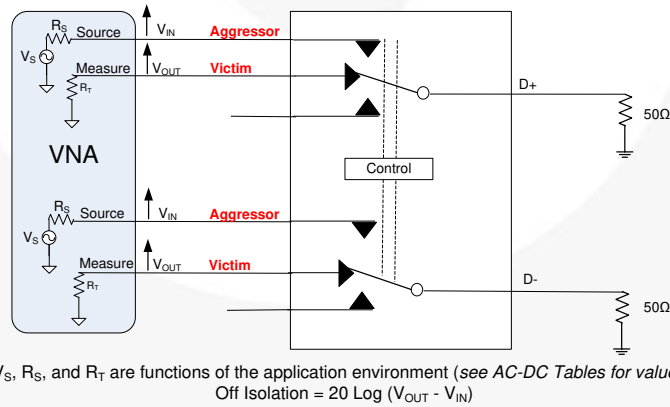
**Figure 11. Break-Before-Make Interval Timing**



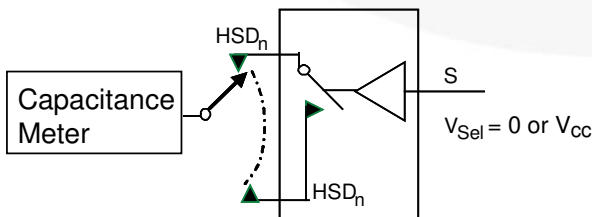
**Figure 12. Insertion Loss (SDD21)**



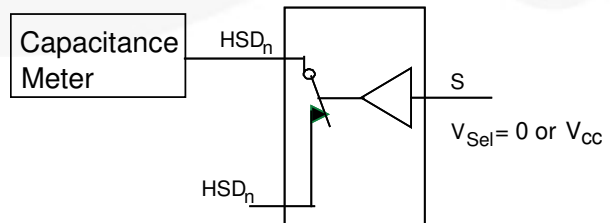
**Figure 13. Channel Off Isolation (SDD21)**



**Figure 14. Non-Adjacent Channel-to-Channel Crosstalk (SDD21)**



**Figure 15. Channel Off Capacitance**



**Figure 16. Channel On Capacitance**

## Functional Description

### Insertion Loss

One of the key advantages of using the FSA3341 in mobile digital-video applications is the small amount of insertion loss experienced by the received signal as it passes through the switch. This results in minimal degradation to the received eye. One of the ways to measure the quality of the high-data-rate channels is using balanced ports and four-port differential S-parameter analysis, particularly SDD21.

Bandwidth is measured using the S-parameter SDD21 methodology.

### Typical Applications

Figure 19 shows the FSA3341 utilizing the  $V_{BAT}$  connection. The 3 MΩ resistors are used to ensure, for manufacturing test via the micro-USB connector, that the FSA3341 configures for connectivity to the baseband or application processor.

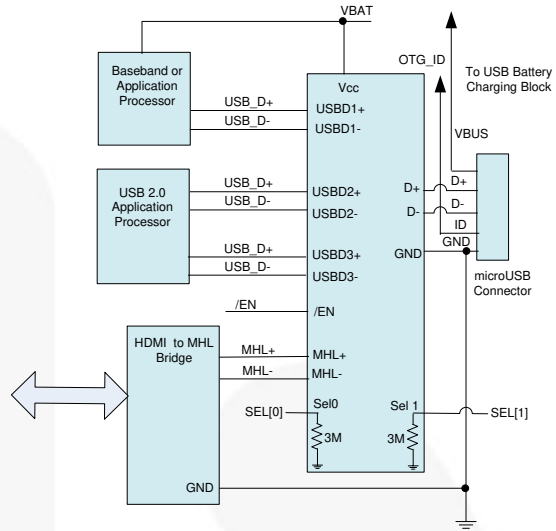


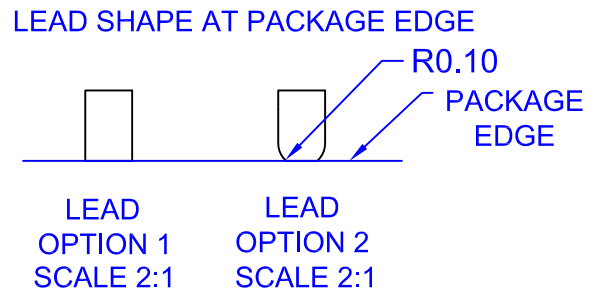
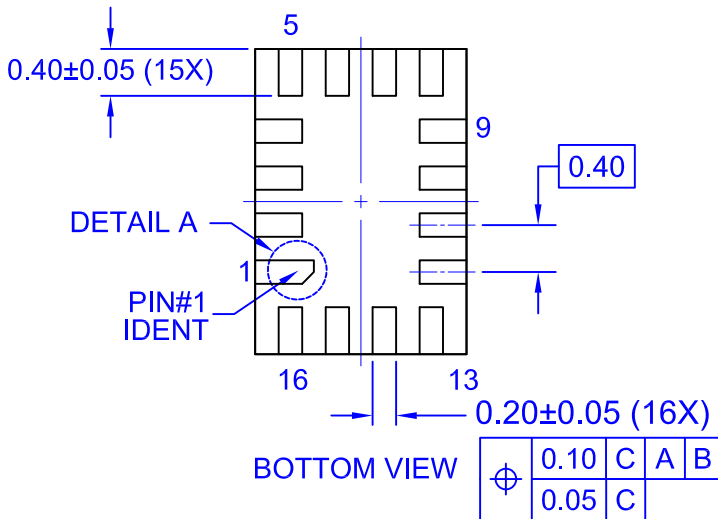
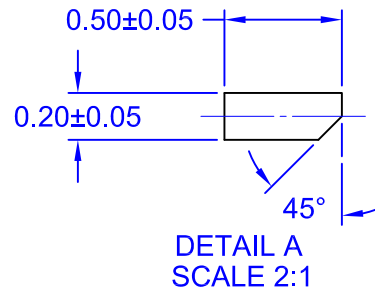
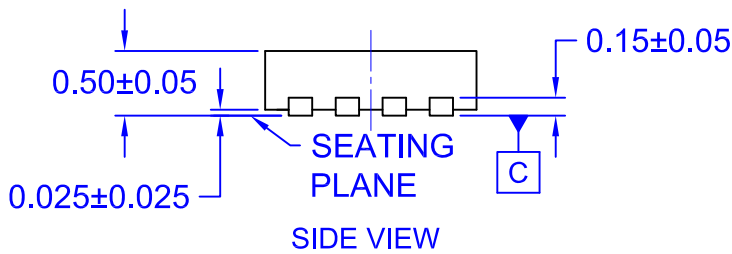
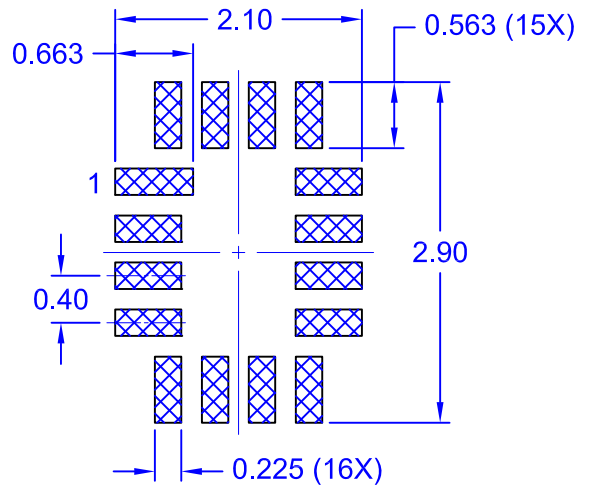
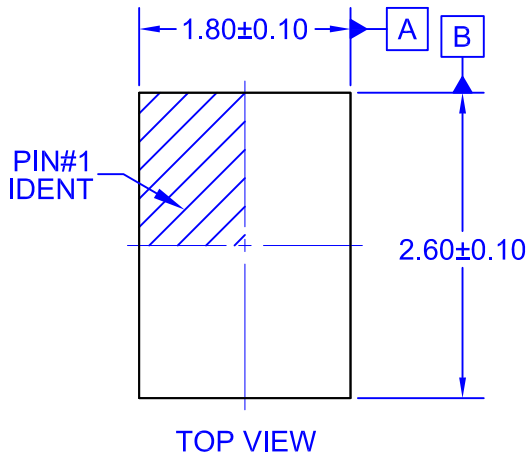
Figure 19. Typical Application



Figure 17. MHL Path SDD21 Insertion Loss Curve



Figure 18. USB Path SDD21 Insertion Loss Curve



NOTES:

- A. PACKAGE DOES NOT FULLY CONFORM TO JEDEC STANDARD.
- B. DIMENSIONS ARE IN MILLIMETERS.
- C. LAND PATTERN RECOMMENDATION IS EXISTING INDUSTRY LAND PATTERN.
- D. DRAWING FILENAME: MKT-UMLP16ArevG.
- E. TERMINAL SHAPE MAY VARY ACCORDING TO PACKAGE SUPPLIER, SEE TERMINAL SHAPE VARIANTS.

ON Semiconductor



ON Semiconductor and  are trademarks of Semiconductor Components Industries, LLC dba ON Semiconductor or its subsidiaries in the United States and/or other countries. ON Semiconductor owns the rights to a number of patents, trademarks, copyrights, trade secrets, and other intellectual property. A listing of ON Semiconductor's product/patent coverage may be accessed at [www.onsemi.com/site/pdf/Patent-Marking.pdf](http://www.onsemi.com/site/pdf/Patent-Marking.pdf). ON Semiconductor reserves the right to make changes without further notice to any products herein. ON Semiconductor makes no warranty, representation or guarantee regarding the suitability of its products for any particular purpose, nor does ON Semiconductor assume any liability arising out of the application or use of any product or circuit, and specifically disclaims any and all liability, including without limitation special, consequential or incidental damages. Buyer is responsible for its products and applications using ON Semiconductor products, including compliance with all laws, regulations and safety requirements or standards, regardless of any support or applications information provided by ON Semiconductor. "Typical" parameters which may be provided in ON Semiconductor data sheets and/or specifications can and do vary in different applications and actual performance may vary over time. All operating parameters, including "Typicals" must be validated for each customer application by customer's technical experts. ON Semiconductor does not convey any license under its patent rights nor the rights of others. ON Semiconductor products are not designed, intended, or authorized for use as a critical component in life support systems or any FDA Class 3 medical devices or medical devices with a same or similar classification in a foreign jurisdiction or any devices intended for implantation in the human body. Should Buyer purchase or use ON Semiconductor products for any such unintended or unauthorized application, Buyer shall indemnify and hold ON Semiconductor and its officers, employees, subsidiaries, affiliates, and distributors harmless against all claims, costs, damages, and expenses, and reasonable attorney fees arising out of, directly or indirectly, any claim of personal injury or death associated with such unintended or unauthorized use, even if such claim alleges that ON Semiconductor was negligent regarding the design or manufacture of the part. ON Semiconductor is an Equal Opportunity/Affirmative Action Employer. This literature is subject to all applicable copyright laws and is not for resale in any manner.

## PUBLICATION ORDERING INFORMATION

### LITERATURE FULFILLMENT:

Literature Distribution Center for ON Semiconductor  
19521 E. 32nd Pkwy, Aurora, Colorado 80011 USA  
**Phone:** 303-675-2175 or 800-344-3860 Toll Free USA/Canada  
**Fax:** 303-675-2176 or 800-344-3867 Toll Free USA/Canada  
**Email:** [orderlit@onsemi.com](mailto:orderlit@onsemi.com)

**N. American Technical Support:** 800-282-9855 Toll Free  
USA/Canada  
**Europe, Middle East and Africa Technical Support:**  
Phone: 421 33 790 2910  
**Japan Customer Focus Center**  
Phone: 81-3-5817-1050

**ON Semiconductor Website:** [www.onsemi.com](http://www.onsemi.com)  
**Order Literature:** <http://www.onsemi.com/orderlit>  
For additional information, please contact your local  
Sales Representative