



Chipsmall Limited consists of a professional team with an average of over 10 year of expertise in the distribution of electronic components. Based in Hongkong, we have already established firm and mutual-benefit business relationships with customers from,Europe,America and south Asia,supplying obsolete and hard-to-find components to meet their specific needs.

With the principle of “Quality Parts,Customers Priority,Honest Operation,and Considerate Service”,our business mainly focus on the distribution of electronic components. Line cards we deal with include Microchip,ALPS,ROHM,Xilinx,Pulse,ON,Everlight and Freescale. Main products comprise IC,Modules,Potentiometer,IC Socket,Relay,Connector.Our parts cover such applications as commercial,industrial, and automotives areas.

We are looking forward to setting up business relationship with you and hope to provide you with the best service and solution. Let us make a better world for our industry!



Contact us

Tel: +86-755-8981 8866 Fax: +86-755-8427 6832

Email & Skype: info@chipsmall.com Web: www.chipsmall.com

Address: A1208, Overseas Decoration Building, #122 Zhenhua RD., Futian, Shenzhen, China





Is Now Part of



ON Semiconductor®

To learn more about ON Semiconductor, please visit our website at
www.onsemi.com

ON Semiconductor and the ON Semiconductor logo are trademarks of Semiconductor Components Industries, LLC dba ON Semiconductor or its subsidiaries in the United States and/or other countries. ON Semiconductor owns the rights to a number of patents, trademarks, copyrights, trade secrets, and other intellectual property. A listing of ON Semiconductor's product/patent coverage may be accessed at www.onsemi.com/site/pdf/Patent-Marking.pdf. ON Semiconductor reserves the right to make changes without further notice to any products herein. ON Semiconductor makes no warranty, representation or guarantee regarding the suitability of its products for any particular purpose, nor does ON Semiconductor assume any liability arising out of the application or use of any product or circuit, and specifically disclaims any and all liability, including without limitation special, consequential or incidental damages. Buyer is responsible for its products and applications using ON Semiconductor products, including compliance with all laws, regulations and safety requirements or standards, regardless of any support or applications information provided by ON Semiconductor. "Typical" parameters which may be provided in ON Semiconductor data sheets and/or specifications can and do vary in different applications and actual performance may vary over time. All operating parameters, including "Typicals" must be validated for each customer application by customer's technical experts. ON Semiconductor does not convey any license under its patent rights nor the rights of others. ON Semiconductor products are not designed, intended, or authorized for use as a critical component in life support systems or any FDA Class 3 medical devices or medical devices with a same or similar classification in a foreign jurisdiction or any devices intended for implantation in the human body. Should Buyer purchase or use ON Semiconductor products for any such unintended or unauthorized application, Buyer shall indemnify and hold ON Semiconductor and its officers, employees, subsidiaries, affiliates, and distributors harmless against all claims, costs, damages, and expenses, and reasonable attorney fees arising out of, directly or indirectly, any claim of personal injury or death associated with such unintended or unauthorized use, even if such claim alleges that ON Semiconductor was negligent regarding the design or manufacture of the part. ON Semiconductor is an Equal Opportunity/Affirmative Action Employer. This literature is subject to all applicable copyright laws and is not for resale in any manner.

FSA5157

0.4Ω Low-Voltage SPDT Analog Switch

Features

- Typical 0.4Ω On Resistance (R_{ON}) for +2.7V Supply
- FSA5157 Features Less than 12μA I_{CCT} Current When S Input is Lower than V_{CC}
- 0.25Ω Maximum R_{ON} Flatness for +2.7V Supply
- 1.0 x 1.45mm 6-Lead MicroPak™ Package
- Broad V_{CC} Operating Range: 1.65V to 4.3V
- Low THD (0.02% Typical for 32Ω Load)
- High-Current Handling Capability (350mA Continuous Current Under 3.3V Supply)
- Control Logic is 1.8V CMOS Logic Compatible

Applications

- Cellular Phone
- PDA
- Portable Media Player

General Description

The FSA5157 is a low on resistance, low-power, Single Pole Double Throw (SPDT) analog switch. This product has been designed for switching audio signals in applications such as cell phones and portable media players. The ultra-low 0.4Ω impedance, sub-μA current consumption, and 1.65V to 4.3V operating voltage range makes this product ideal for battery-powered applications. The FSA5157 also features bi-directional operation and break-before-make functionality. This device is fully specified for operation at 1.8V, 2.5V, and 3.3V.

A growing number of applications require the voltage applied to the select input to be lower than the V_{CC} applied. Under this condition, most switches would typically consume over 100μA of current. This would be an unacceptable level for battery-powered applications. The FSA5157 is designed to minimize current consumption under this condition. The I_{CCT} is specified for <12μA under a worst-case condition of $V_{CC} = 4.3V$ and $V_{IN} = 1.8V$.

Ordering Information

Order Number	Top Mark	Package Description	Packing Method
FSA5157P6X	C57	6-Lead SC70, EIAJ SC88, 1.25mm Wide	3000 Units on Tape and Reel
FSA5157L6X	FT	6-Lead MicroPak, 1.0mm Wide	5000 Units on Tape and Reel

 All packages are lead free per JEDEC: J-STD-020B standard.

Application Diagram

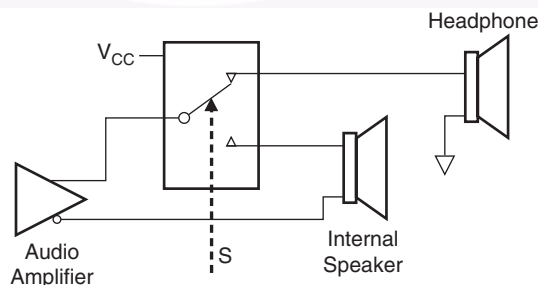

Figure 1. Application Diagram

MicroPak™ is a trademark of Fairchild Semiconductor Corporation.

Pin Assignments

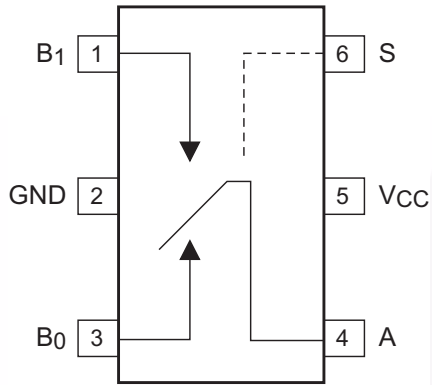

Figure 2. 6-Lead SC70

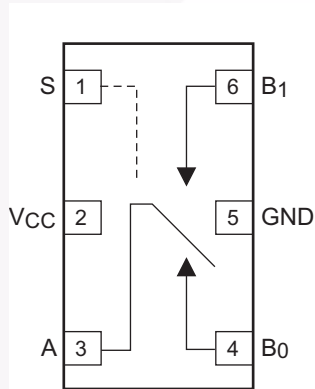

Figure 3. 6-Lead MicroPak™

Truth Tables

Control Input(s)	Function
LOW Logic Level	B ₀ Connected to A
HIGH Logic Level	B ₁ Connected to A

Pin Descriptions

Pin Names	Function
A, B ₀ , B ₁	Data Ports
S	Control Input

Absolute Maximum Ratings

Stresses exceeding the absolute maximum ratings may damage the device. The device may not function or be operable above the recommended operating conditions and stressing the parts to these levels is not recommended. In addition, extended exposure to stresses above the recommended operating conditions may affect device reliability. The absolute maximum ratings are stress ratings only.

Symbol	Parameter	Min.	Max	Units
V_{CC}	Supply Voltage	-0.5	5.5	V
V_S	Switch Voltage ⁽¹⁾	-0.5	$V_{CC} + 0.3V$	V
V_{IN}	Input Voltage ⁽¹⁾	-0.5	V_{CC}	V
I_{IK}	Input Diode Current		-50	mA
I_{SW}	Switch Current		350	mA
I_{SWPEAK}	Peak Switch Current (Pulsed at 1ms duration, <10% Duty Cycle)		500	mA
P_D	SC70 6L Package		180	mW
	MicroPak 6L Package		180	mW
T_{STG}	Storage Temperature Range	-65	+150	°C
T_J	Maximum Junction Temperature		+150	°C
T_L	Lead Temperature Soldering, 10 seconds		+260	°C
ESD	Human Body Model		8000	V

Note:

1. The input and output negative voltage ratings may be exceeded if the input and output diode current ratings are observed.

Recommended Operating Conditions

The Recommended Operating Conditions table defines the conditions for actual device operation. Recommended operating conditions are specified to ensure optimal performance to the datasheet specifications. Fairchild does not recommend exceeding them or designing to absolute maximum ratings.

Symbol	Parameter	Min.	Max.	Rating
V_{CC}	Supply Voltage	1.65	4.30	V
V_{IN}	Control Input Voltage ⁽²⁾	0	V_{CC}	V
V_{IN}	Switch Input Voltage	0	V_{CC}	V
T_A	Operating Temperature	-40	+85	°C

Note:

2. Unused inputs must be held HIGH or LOW. They may not float.

DC Electrical Characteristics

All typical values are at 25°C unless otherwise specified.

Symbol	Parameter	Conditions	V _{CC} (V)	T _A =+25°C			T _A = -40°C to +85°C		Units	
				Min.	Typ.	Max.	Min.	Max.		
V _{IH}	Input Voltage High		3.6 to 4.3				1.4		V	
			2.7 to 3.6				1.3			
			2.3 to 2.7				1.1			
			1.65 to 1.95				0.9			
V _{IL}	Input Voltage Low		3.6 to 4.3					0.7	V	
			2.7 to 3.6					0.5		
			2.3 to 2.7					0.4		
			1.65 to 1.95					0.4		
I _{IN}	Control Input Leakage	V _{IN} = 0V to V _{CC}	1.65 to 4.3				-0.5	0.5	μA	
I _{NO(OFF)} , I _{NC(OFF)}	Off-Leakage Current of Port B ₀ and B ₁	A = 0.3V, V _{CC} = 0.3V, B ₀ or B ₁ = 0.3V, V _{CC} = 0.3V or Floating	1.95 to 4.3	-10		10	-50	50	nA	
I _{A(ON)}	On Leakage Current of Port A	A = 0.3V, V _{CC} = 0.3V, B ₀ or B ₁ = 0.3V, V _{CC} = 0.3V or Floating	1.95 to 4.3	-20		20	-100	100	nA	
R _{ON}	Switch On Resistance ⁽³⁾		I _{OUT} = 100mA, B ₀ or B ₁ = 0V, 0.7V, 3.6V, 4.3V	4.3		0.36			0.60	Ω
			I _{OUT} = 100mA, B ₀ or B ₁ = 0V, 0.7V, 2.0V, 2.7V	2.7		0.4			0.7	
			I _{OUT} = 100mA, B ₀ or B ₁ = 0V, 0.7V, 2.0V, 2.3V	2.3		0.55			0.80	
			I _{OUT} = 100mA, B ₀ or B ₁ = 0.7V	1.65		1.5	2.5		3.0	
ΔR _{ON}	On Resistance Matching Between Channels ⁽⁴⁾	I _{OUT} = 100mA, B ₀ or B ₁ = 0.7V	4.3		0.04				0.75	Ω
			2.7		0.06				0.13	
			2.3		0.12				0.20	
			1.65		1.0					
R _{FLAT(ON)}	On Resistance Flatness ⁽⁵⁾	I _{OUT} = 100mA, B ₀ or B ₁ = 0V to V _{CC}	4.3						0.25	Ω
			2.7						0.25	
			2.3						0.3	
			1.65		0.3					
I _{CC}	Quiescent Supply Current	V _{IN} = 0V or V _{CC} , I _{OUT} = 0	4.3	-100	30	100	-500	500	nA	
I _{CCT}	Increase in I _{CC} per Control Input	V _{IN} = 1.8V	4.3		7.0	12.0		15.0	μA	
		V _{IN} = 2.6V	4.3		3.0	6.0		7.0		

Notes:

- On resistance is determined by the voltage drop between A and B pins at the indicated current through the switch.
- ΔR_{ON} = R_{ONmax} - R_{ONmin} measured at identical V_{CC}, temperature, and voltage.
- Flatness is defined as the difference between the maximum and minimum value of on resistance over the specified range of conditions.

AC Electrical Characteristics

All typical values are at 25°C unless otherwise specified.

Symbol	Parameter	Conditions	V _{CC} (V)	T _A = +25°C			T _A = -40°C to +85°C		Units	Figure
				Min.	Typ.	Max.	Min.	Max.		
t _{ON}	Turn-On Time	B ₀ or B ₁ = 1.5V, R _L = 50Ω, C _L = 35pF	3.6 to 4.3			55		60	ns	Figure 7
			2.7 to 3.6			60		65		
			2.3 to 2.7			65		70		
			1.65 to 1.95		70		90			
t _{OFF}	Turn-Off Time	B ₀ or B ₁ = 1.5V, R _L = 50Ω, C _L = 35pF	3.6 to 4.3			30		35	ns	Figure 7
			2.7 to 3.6			35		40		
			2.3 to 2.7			40		45		
			1.65 to 1.95		40		55			
t _{BBM}	Break-Before-Make Time	B ₀ or B ₁ = 1.5V, R _L = 50Ω, C _L = 35pF	3.6 to 4.3				5		ns	Figure 8
			2.7 to 3.6				5			
			2.3 to 2.7				5			
			1.65 to 1.95				5			
Q	Charge Injection	C _L = 1.0 nF, V _{GEN} = 0V, R _{GEN} = 0Ω	3.6 to 4.3		6				pC	Figure 11
			2.7 to 3.6		6					
			2.3 to 2.7		6					
			1.65 to 1.95							
OIRR	Off-Isolation	f = 100kHz, R _L = 50Ω, C _L = 5pF (Stray)	3.6 to 4.3		-75				dB	Figure 9
			2.7 to 3.6		-75					
			2.3 to 2.7		-75					
			1.65 to 1.95		-75					
Xtalk	Crosstalk	f = 100kHz, R _L = 50Ω, C _L = 5pF (Stray)	3.6 to 4.3		-75				dB	Figure 10
			2.7 to 3.6		-75					
			2.3 to 2.7		-75					
			1.65 to 1.95		-70					
BW	-3db Bandwidth	R _L = 50Ω	1.65 to 4.3		80				MHz	Figure 13
THD	Total Harmonic Distortion	R _L = 32Ω, V _{IN} = 2V _{PP} , f = 20Hz to 20kHz	3.6 to 4.3						%	Figure 14
			2.7 to 3.6		0.02					
			2.3 to 2.7		0.036					
			1.65 to 1.95		0.01					

Capacitance

Symbol	Parameter	Conditions	V _{CC} (V)	T _A = +25°C			T _A = 40°C to +85°C		Units	Figure
				Min.	Typ.	Max.	Min.	Max.		
C _{IN}	Control Pin Input Capacitance	f = 1MHz	0.0		1.5				pF	Figure 12
C _{OFF}	B Port OFF Capacitance	f = 1MHz	4.5		21.0				pF	Figure 12
C _{ON}	A Port ON Capacitance	f = 1MHz	4.5		90.0				pF	Figure 12

Typical Characteristics

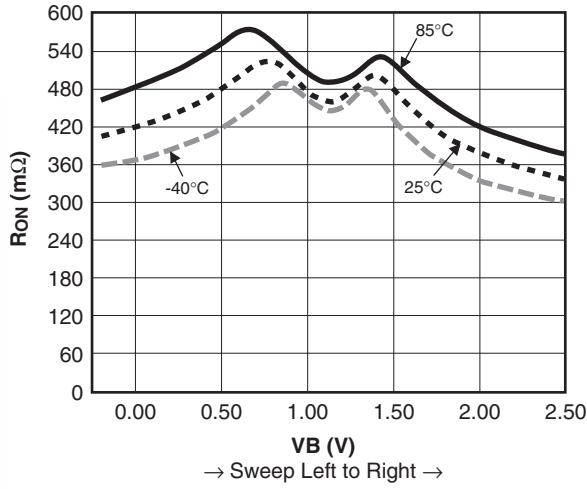

Figure 4. R_{ON} Switch On Resistance, $I_{ON} = 100\text{mA}$, $V_{CC} = 2.3\text{V B0}$

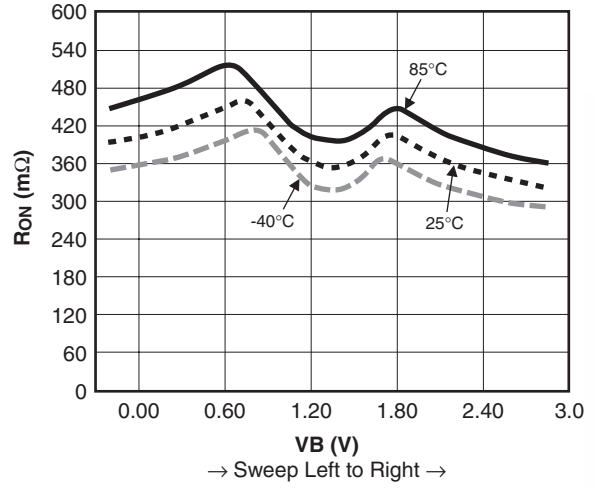

Figure 5. R_{ON} Switch On Resistance, $I_{ON} = 100\text{mA}$, $V_{CC} = 2.7\text{V B0}$

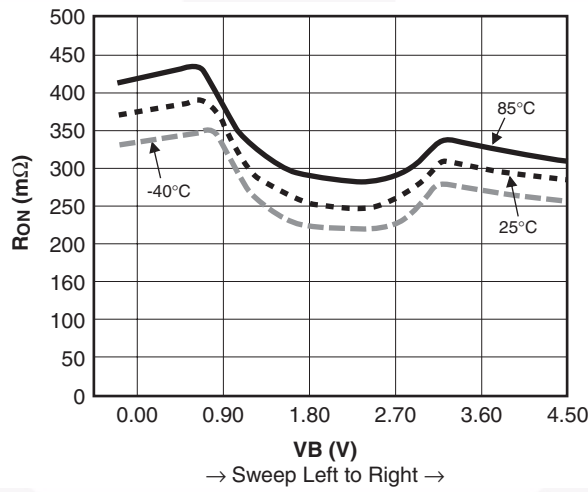
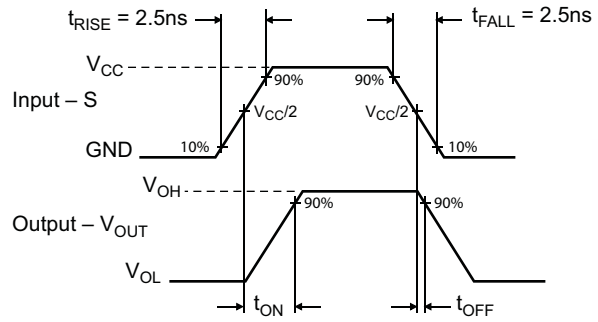
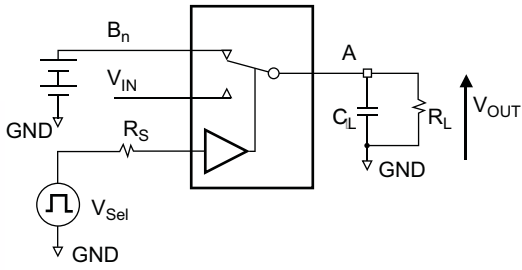

Figure 6. R_{ON} Switch On Resistance, $I_{ON} = 100\text{mA}$, $V_{CC} = 4.3\text{V B0}$

AC Loading and Waveforms



Notes:

- 6. R_L , R_S , and C_L are functions of the application environment (see AC Electrical table for specific values).
- 7. C_L includes test fixture and stray capacitance.

Figure 7. Turn-Off Timing

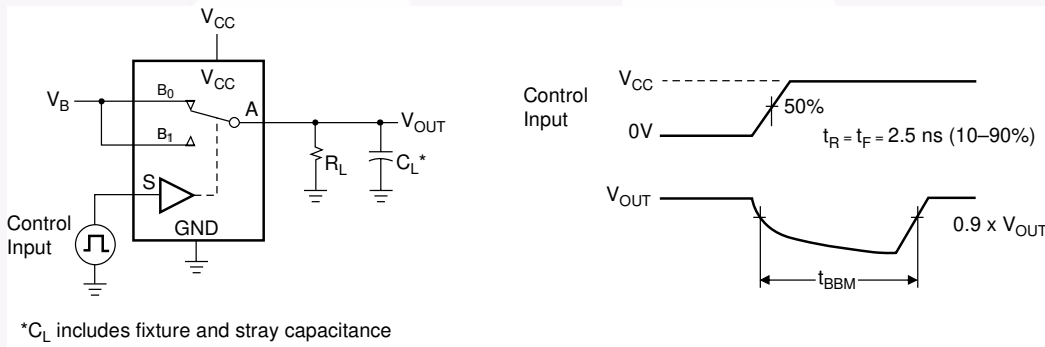

* C_L includes fixture and stray capacitance

Figure 8. Break-Before-Make Timing

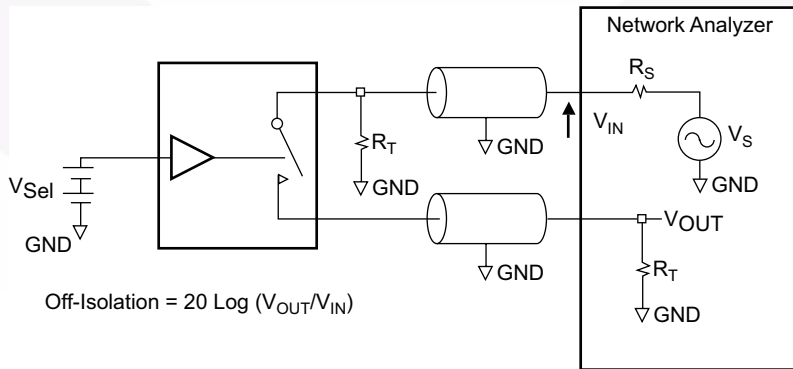

Figure 9. Off Isolation

AC Loading and Waveforms (continued)

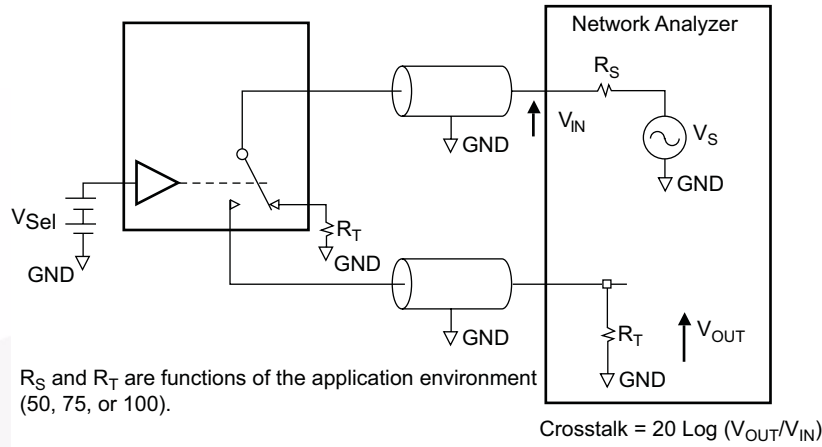

Figure 10. Non-Adjacent Channel-to-Channel Crosstalk

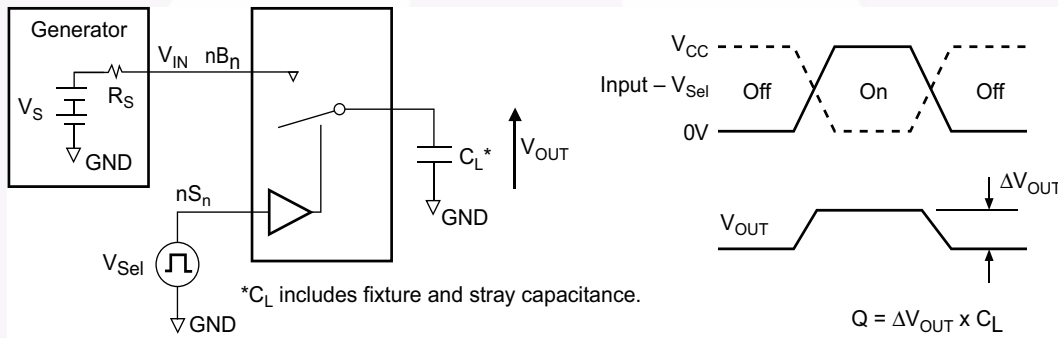

Figure 11. Charge Injection Test

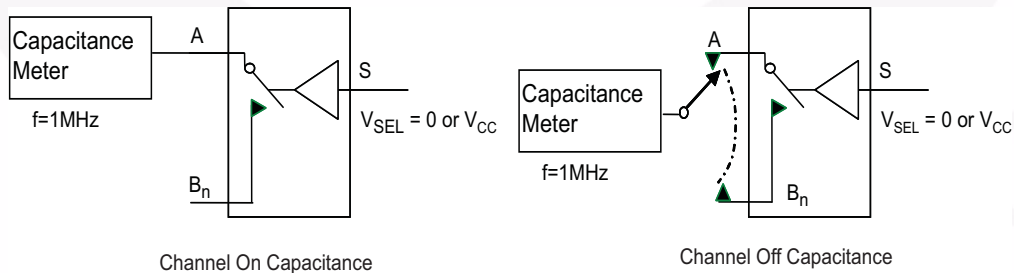

Figure 12. On/Off Capacitance Measurement Setup

AC Loading and Waveforms (continued)

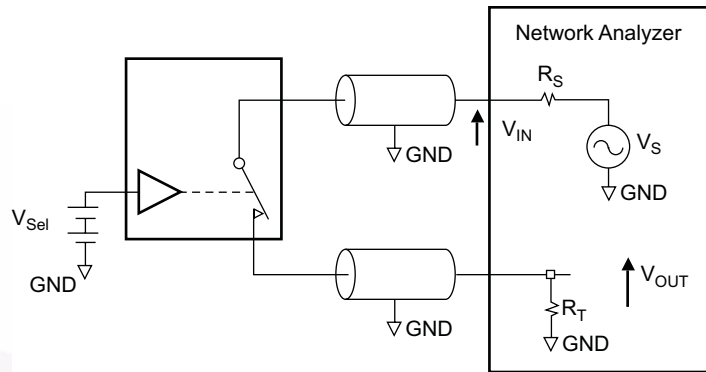

Figure 13. Bandwidth

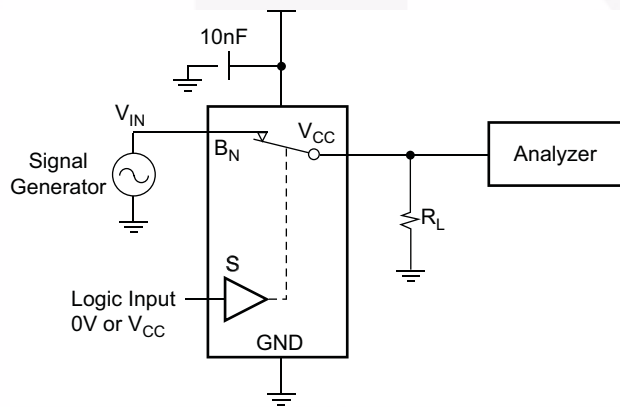
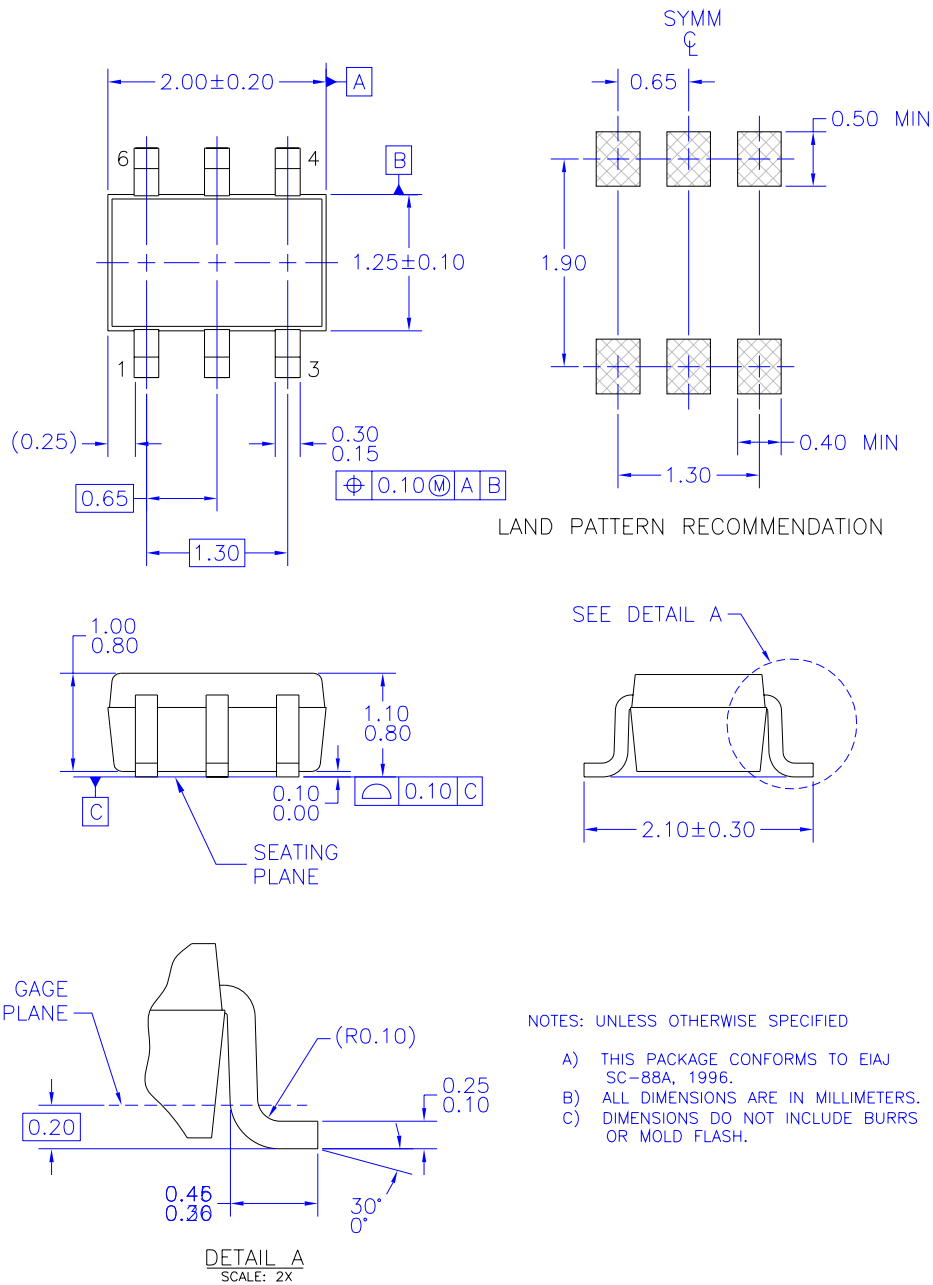

Figure 14. Harmonic Distortion



Physical Dimensions



MAA06AREV5

Figure 15. 6-Lead SC70, EIAJ SC88, 1.25mm Wide

Package drawings are provided as a service to customers considering Fairchild components. Drawings may change in any manner without notice. Please note the revision and/or date on the drawing and contact a Fairchild Semiconductor representative to verify or obtain the most recent revision. Package specifications do not expand the terms of Fairchild's worldwide terms and conditions, specifically the warranty therein, which covers Fairchild products.

Always visit Fairchild Semiconductor's online packaging area for the most recent package drawings:

<http://www.fairchildsemi.com/packaging/>

Physical Dimensions

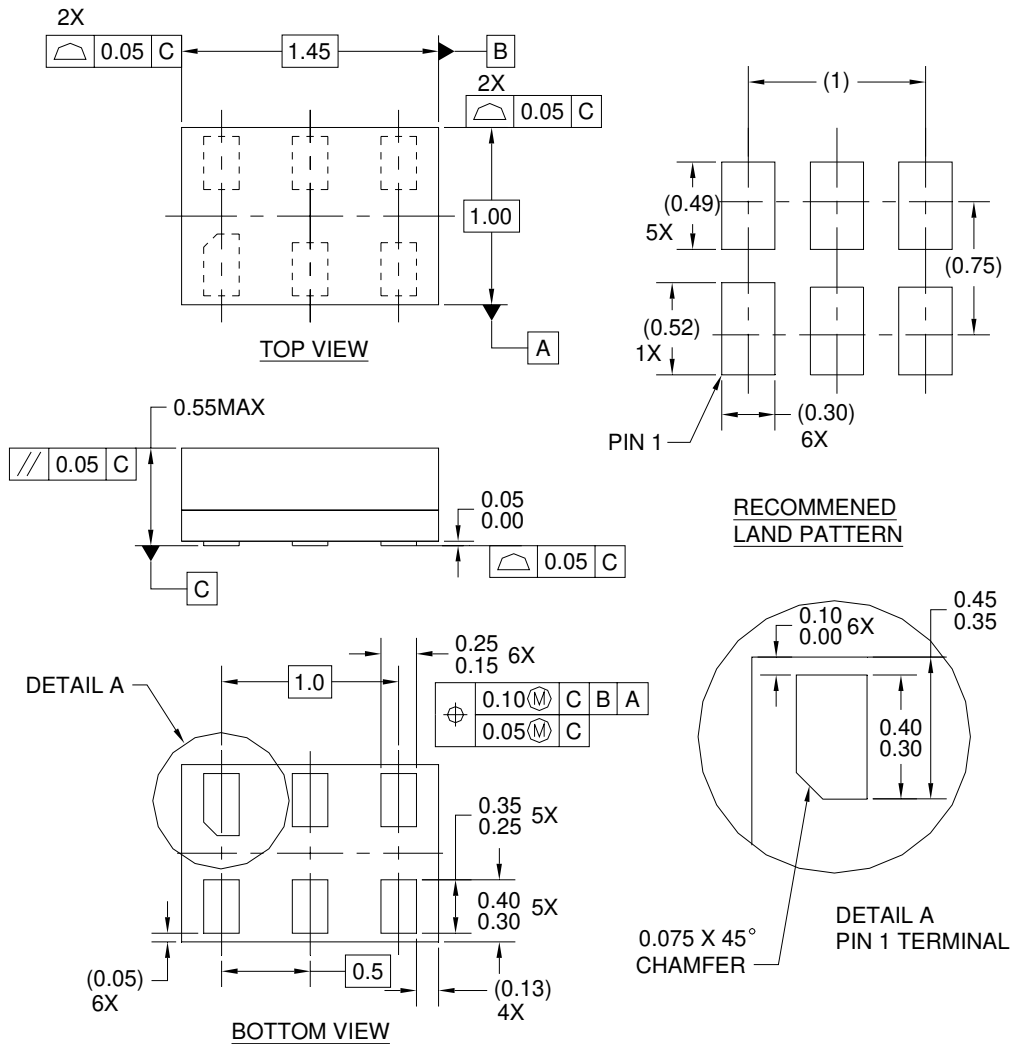

MAC06AREVC

Figure 16. 6-Lead MicroPak™, 1.0mm Wide

Package drawings are provided as a service to customers considering Fairchild components. Drawings may change in any manner without notice. Please note the revision and/or date on the drawing and contact a Fairchild Semiconductor representative to verify or obtain the most recent revision. Package specifications do not expand the terms of Fairchild's worldwide terms and conditions, specifically the warranty therein, which covers Fairchild products.

Always visit Fairchild Semiconductor's online packaging area for the most recent package drawings:
<http://www.fairchildsemi.com/packaging/>

For MicroPak tape and reel specifications, please visit Fairchild Semiconductor's online packaging area:
http://www.fairchildsemi.com/products/logic/pdf/micropak_tr.pdf



TRADEMARKS

The following includes registered and unregistered trademarks and service marks, owned by Fairchild Semiconductor and/or its global subsidiaries, and is not intended to be an exhaustive list of all such trademarks.

- | | | | |
|---|--|--|----------------------------------|
| ACEx [®] | FPS [™] | PDP-SPM [™] | SupreMOS [™] |
| Build it Now [™] | FRFET [®] | Power220 [®] | SyncFET [™] |
| CorePLUS [™] | Global Power Resource SM | POWEREDGE [®] | SYSTEM [®] |
| CROSSVOL [™] | Green FPS [™] | Power-SPM [™] | GENERAL [®] |
| CTL [™] | Green FPS [™] e-Series [™] | PowerTrench [®] | The Power Franchise [®] |
| Current Transfer Logic [™] | GTO [™] | Programmable Active Droop [™] | the Power [®] |
| EcoSPARK [®] | i-Lo [™] | QFET [®] | franchise [®] |
| EZSWITCH [™] * | IntelliMAX [™] | QS [™] | TinyBoost [™] |
|  | ISOPLANAR [™] | QT Optoelectronics [™] | TinyBuck [™] |
|  | MegaBuck [™] | Quiet Series [™] | TinyLogic [®] |
| Fairchild [®] | MICROCOUPLER [™] | RapidConfigure [™] | TINYOPTO [™] |
| Fairchild Semiconductor [®] | MicroFET [™] | SMART START [™] | TinyPower [™] |
| FACT Quiet Series [™] | MicroPak [™] | SPM [®] | TinyPVM [™] |
| FACT [®] | MillerDrive [™] | STEALTH [™] | TinyWire [™] |
| FAST [®] | Motion-SPM [™] | SuperFET [™] | µSerDes [™] |
| FastvCore [™] | OPTOLOGIC [®] | SuperSOT [™] -3 | UHC [®] |
| FlashWriter [®] * | OPTOPLANAR [®] | SuperSOT [™] -6 | Ultra FRFET [™] |
| | | SuperSOT [™] -8 | UniFET [™] |
| | | | VCX [™] |

* EZSWITCH[™] and FlashWriter[®] are trademarks of System General Corporation, used under license by Fairchild Semiconductor.

DISCLAIMER

FAIRCHILD SEMICONDUCTOR RESERVES THE RIGHT TO MAKE CHANGES WITHOUT FURTHER NOTICE TO ANY PRODUCTS HEREIN TO IMPROVE RELIABILITY, FUNCTION, OR DESIGN. FAIRCHILD DOES NOT ASSUME ANY LIABILITY ARISING OUT OF THE APPLICATION OR USE OF ANY PRODUCT OR CIRCUIT DESCRIBED HEREIN; NEITHER DOES IT CONVEY ANY LICENSE UNDER ITS PATENT RIGHTS, NOR THE RIGHTS OF OTHERS. THESE SPECIFICATIONS DO NOT EXPAND THE TERMS OF FAIRCHILD'S WORLDWIDE TERMS AND CONDITIONS, SPECIFICALLY THE WARRANTY THEREIN, WHICH COVERS THESE PRODUCTS.

LIFE SUPPORT POLICY

FAIRCHILD'S PRODUCTS ARE NOT AUTHORIZED FOR USE AS CRITICAL COMPONENTS IN LIFE SUPPORT DEVICES OR SYSTEMS WITHOUT THE EXPRESS WRITTEN APPROVAL OF FAIRCHILD SEMICONDUCTOR CORPORATION.

As used herein:

1. Life support devices or systems are devices or systems which, (a) are intended for surgical implant into the body or (b) support or sustain life, and (c) whose failure to perform when properly used in accordance with instructions for use provided in the labeling, can be reasonably expected to result in a significant injury of the user.
2. A critical component in any component of a life support, device, or system whose failure to perform can be reasonably expected to cause the failure of the life support device or system, or to affect its safety or effectiveness.

PRODUCT STATUS DEFINITIONS

Definition of Terms

Datasheet Identification	Product Status	Definition
Advance Information	Formative or In Design	This datasheet contains the design specifications for product development. Specifications may change in any manner without notice.
Preliminary	First Production	This datasheet contains preliminary data; supplementary data will be published at a later date. Fairchild Semiconductor reserves the right to make changes at any time without notice to improve design.
No Identification Needed	Full Production	This datasheet contains final specifications. Fairchild Semiconductor reserves the right to make changes at any time without notice to improve the design.
Obsolete	Not In Production	This datasheet contains specifications on a product that has been discontinued by Fairchild Semiconductor. The datasheet is printed for reference information only.

Rev. 133

ON Semiconductor and  are trademarks of Semiconductor Components Industries, LLC dba ON Semiconductor or its subsidiaries in the United States and/or other countries. ON Semiconductor owns the rights to a number of patents, trademarks, copyrights, trade secrets, and other intellectual property. A listing of ON Semiconductor's product/patent coverage may be accessed at www.onsemi.com/site/pdf/Patent-Marking.pdf. ON Semiconductor reserves the right to make changes without further notice to any products herein. ON Semiconductor makes no warranty, representation or guarantee regarding the suitability of its products for any particular purpose, nor does ON Semiconductor assume any liability arising out of the application or use of any product or circuit, and specifically disclaims any and all liability, including without limitation special, consequential or incidental damages. Buyer is responsible for its products and applications using ON Semiconductor products, including compliance with all laws, regulations and safety requirements or standards, regardless of any support or applications information provided by ON Semiconductor. "Typical" parameters which may be provided in ON Semiconductor data sheets and/or specifications can and do vary in different applications and actual performance may vary over time. All operating parameters, including "Typicals" must be validated for each customer application by customer's technical experts. ON Semiconductor does not convey any license under its patent rights nor the rights of others. ON Semiconductor products are not designed, intended, or authorized for use as a critical component in life support systems or any FDA Class 3 medical devices or medical devices with a same or similar classification in a foreign jurisdiction or any devices intended for implantation in the human body. Should Buyer purchase or use ON Semiconductor products for any such unintended or unauthorized application, Buyer shall indemnify and hold ON Semiconductor and its officers, employees, subsidiaries, affiliates, and distributors harmless against all claims, costs, damages, and expenses, and reasonable attorney fees arising out of, directly or indirectly, any claim of personal injury or death associated with such unintended or unauthorized use, even if such claim alleges that ON Semiconductor was negligent regarding the design or manufacture of the part. ON Semiconductor is an Equal Opportunity/Affirmative Action Employer. This literature is subject to all applicable copyright laws and is not for resale in any manner.

PUBLICATION ORDERING INFORMATION

LITERATURE FULFILLMENT:

Literature Distribution Center for ON Semiconductor
19521 E. 32nd Pkwy, Aurora, Colorado 80011 USA
Phone: 303-675-2175 or 800-344-3860 Toll Free USA/Canada
Fax: 303-675-2176 or 800-344-3867 Toll Free USA/Canada
Email: orderlit@onsemi.com

N. American Technical Support: 800-282-9855 Toll Free
USA/Canada
Europe, Middle East and Africa Technical Support:
Phone: 421 33 790 2910
Japan Customer Focus Center
Phone: 81-3-5817-1050

ON Semiconductor Website: www.onsemi.com
Order Literature: <http://www.onsemi.com/orderlit>
For additional information, please contact your local
Sales Representative