



Chipsmall Limited consists of a professional team with an average of over 10 year of expertise in the distribution of electronic components. Based in Hongkong, we have already established firm and mutual-benefit business relationships with customers from,Europe,America and south Asia,supplying obsolete and hard-to-find components to meet their specific needs.

With the principle of "Quality Parts,Customers Priority,Honest Operation,and Considerate Service",our business mainly focus on the distribution of electronic components. Line cards we deal with include Microchip,ALPS,ROHM,Xilinx,Pulse,ON,Everlight and Freescale. Main products comprise IC,Modules,Potentiometer,IC Socket,Relay,Connector.Our parts cover such applications as commercial,industrial, and automotives areas.

We are looking forward to setting up business relationship with you and hope to provide you with the best service and solution. Let us make a better world for our industry!



Contact us

Tel: +86-755-8981 8866 Fax: +86-755-8427 6832

Email & Skype: info@chipsmall.com Web: www.chipsmall.com

Address: A1208, Overseas Decoration Building, #122 Zhenhua RD., Futian, Shenzhen, China



Force Sensors

FSA Series, Compensated/Amplified

32311096

Issue B

Datasheet

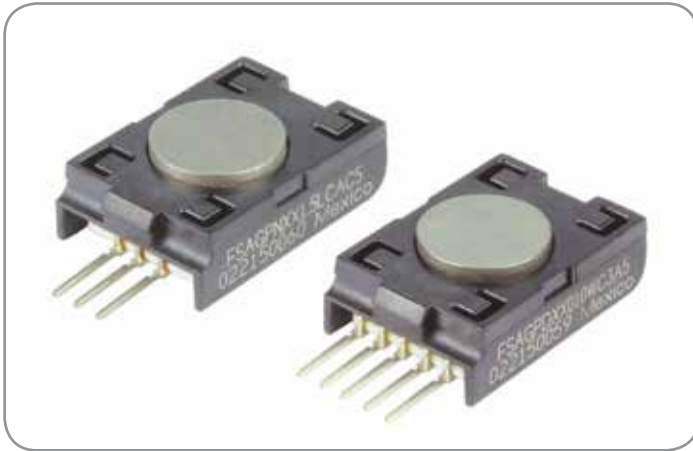

DESCRIPTION

The FSA Series are piezoresistive-based force sensors offering a ratiometric analog or digital output for reading force over the specified full scale force span and temperature range. They are fully calibrated and temperature compensated for sensor offset, sensitivity, temperature effects, and nonlinearity using an on-board Application Specific Integrated Circuit (ASIC). Direct mechanical coupling allows for easy interface with the sensor, coupling with tubing, membrane or a plunger, providing repeatable performance and a reliable mechanical interface to the application. The package also provides excellent corrosion resistance and isolation to external package stress. All products are designed and manufactured according to ISO 9001 standards.

VALUE TO CUSTOMERS

The FSA Series are designed to meet the customers' need for a compensated, amplified force sensor that provides analog and digital outputs, a variety of force sensing ranges, and enhanced durability and accuracy. Their flexible design provides multiple standard configurations over a wide operating temperature range.

DIFFERENTIATION

- Multiple force ranges allow the customer to choose the force range to maximize sensitivity and improve system resolution/performance
- Overforce provides enhanced durability in applications where overforce may exist
- Enhanced accuracy includes all errors due to force non-linearity, force hysteresis, and non-repeatability
- Total Error Band enhances system performance
- Digital output enhances performance through reduced conversion requirements and the convenience of direct interface to microprocessors
- Diagnostics functions allow the user to determine if the sensor is working correctly by detecting if the electrical paths are broken or shorted inside the sensor
- Supply voltage provides customers flexibility of design within the application

FEATURES

- Wide variety of force ranges
 - Newton (N): 5, 7.5, 10, 15, 20, 25
 - pound (lb): 1, 1.5, 2, 3, 5
 - gram (g): 500, 750
 - kilogram (kg): 1, 2
- Total Error Band: $\pm 5\%$ FSS
- Accuracy: $\pm 3\%$ FSS
- Ratiometric analog or SPI- or I²C-compatible digital output
- Fully calibrated and temperature compensated over a temperature range of 5°C to 50°C [41°F to 122°F]
- Overforce: 6804 g [15 lb]
- Supply voltage: 3.3 Vdc typ. or 5.0 Vdc typ.
- Low power consumption: 13 mW (analog) or 20 mW (digital)
- Excellent part-to-part repeatability
- Enhanced reliability
- Stable interface plunger
- Internal diagnostic functions available
- REACH and RoHS compliant

POTENTIAL APPLICATIONS

Medical:

- Ambulatory non-invasive pump pressure
- Infusion pumps
- Kidney dialysis machines
- Occlusion detection

Industrial:

- Load and compression sensing

PORTFOLIO

The FSA Series joins the FSG Series, FSS Series, FSS-SMT Series, TBF Series, and 1865 Series.

Force Sensors, FSA Series Compensated/Amplified

Table 1. Operating Specifications

Characteristic	Analog			Digital			Unit
	Min.	Typ.	Max.	Min.	Typ.	Max.	
Supply voltage (V_{supply}): ^{1,2,3} 3.3 Vdc 5.0 Vdc	3.0 4.75	3.3 5.0	3.6 5.25	3.0 4.75	3.3 5.0	3.6 5.25	Vdc
Supply current: 3.3 Vdc 5.0 Vdc	— —	2.0 2.6	— —	— —	2.8 3.9	3.9 4.6	mA
Power input	13			20			mW
Operating temperature range ⁴	0 [32]	—	70 [158]	0 [32]	—	70 [158]	°C [°F]
Compensated temperature range ⁵	5 [41]	—	50 [122]	5 [41]	—	50 [122]	°C [°F]
Storage temperature range	-40 [-40]	—	85 [185]	-40 [-40]	—	85 [185]	°C [°F]
Startup time (power up to data ready)	—	—	5	—	—	3	ms
Response time	—	1	—	—	0.42	0.84	ms
Clipping limit: upper lower	— 2.5	— —	97.5 —	— —	— —	— —	% V_{supply}
SPI/I ² C voltage level: low high	— —	— —	— —	— 80	— —	20 —	% V_{supply}
Pull up on SDA/MISO, SCL/SCLK, SS	—	—	—	1	—	—	kOhm
Accuracy ⁶	—	—	±3	—	—	±3	%FSS ⁷ BFSL
Total Error Band ⁸	—	—	±5	—	—	±5	%FSS
Output resolution	—	—	—	12	—	—	bits
Long term stability ⁹	—	±1.3	—	—	±1.3	—	%FSS

¹Sensors are either 3.3 Vdc or 5.0 Vdc based on the catalog listing selected.

²Ratiometricity of the sensor (the ability of the device output to scale to the supply voltage) is achieved within the specified operating voltage.

³The sensor is not reverse polarity protected. Incorrect application of supply voltage or ground to the wrong pin may cause electrical failure.

⁴Operating temperature range: The temperature range over which the sensor will produce an output proportional to force.

⁵Compensated temperature range: The temperature range over which the sensor will produce an output proportional to force within the specified performance limits.

⁶Accuracy: The maximum deviation in output from a Best Fit Straight Line (BFSL) fitted to the output measured over the force range at 25°C [77°F]. Includes all errors due to force non-linearity, force hysteresis, and non-repeatability.

⁷Full Scale Span (FSS): The algebraic difference between the output voltage at full scale force and the output at zero force.

⁸Total Error Band (TEB): Combined error from calibration, accuracy and temperature effects over the compensated temperature range at 5.0V from 15 %FSS to 95 %FSS.

⁹Long-term stability after 1000 hr of operation at 25°C [77°F].

Force Sensors, FSA Series Compensated/Amplified

Table 2. Environmental Specifications

Characteristic	Parameter
Humidity	0% to 95% RH, non-condensing
Vibration	MIL-STD-202, Method 214, Condition 1E (16.9 G)
Shock	MIL-STD-202, Method 213, Condition F (1500 G)
Life ¹	1 million full scale force cycles minimum

¹Life may vary depending on specific application in which the sensor is utilized.

Table 3. Materials¹

Component	Material
Covers	high temperature polyamide
Plunger	stainless steel 316
Substrate	alumina, ceramic
Adhesives	epoxy, silicone
Electronic components	ceramic silicon, glass, solder

¹Contact Honeywell customer service for detailed material information.

Table 4. Absolute Maximum Specifications

Characteristic	Min.	Max.	Unit
Supply voltage	-0.3	6.0	Vdc
Voltage on any pin	-0.3	$V_{\text{supply}} + 0.3$	V
Digital interface clock frequency:			
SPI	50	800	kHz
I ² C	100	400	
ESD susceptibility (human body model)	2	—	kV
Storage temperature range	-40 [-40]	85 [185]	°C [°F]
Overforce limit	—	6804 [15]	g [lb]
Minimum operating voltage	2.8 Vdc		
Lead soldering time and temperature	4 s max. at 220°C [428°F]		

Force Sensors, FSA Series Compensated/Amplified

Figure 1. Nomenclature and Order Guide

For example, **FSAGPNXX001LCAA3** defines an FSA Series Force Sensor, gel coupling, plunger contact element, no diagnostics, 2 lb force range, force unit in pounds, compression force type, analog output, 10% to 90% transfer function, 3.3 Vdc supply voltage

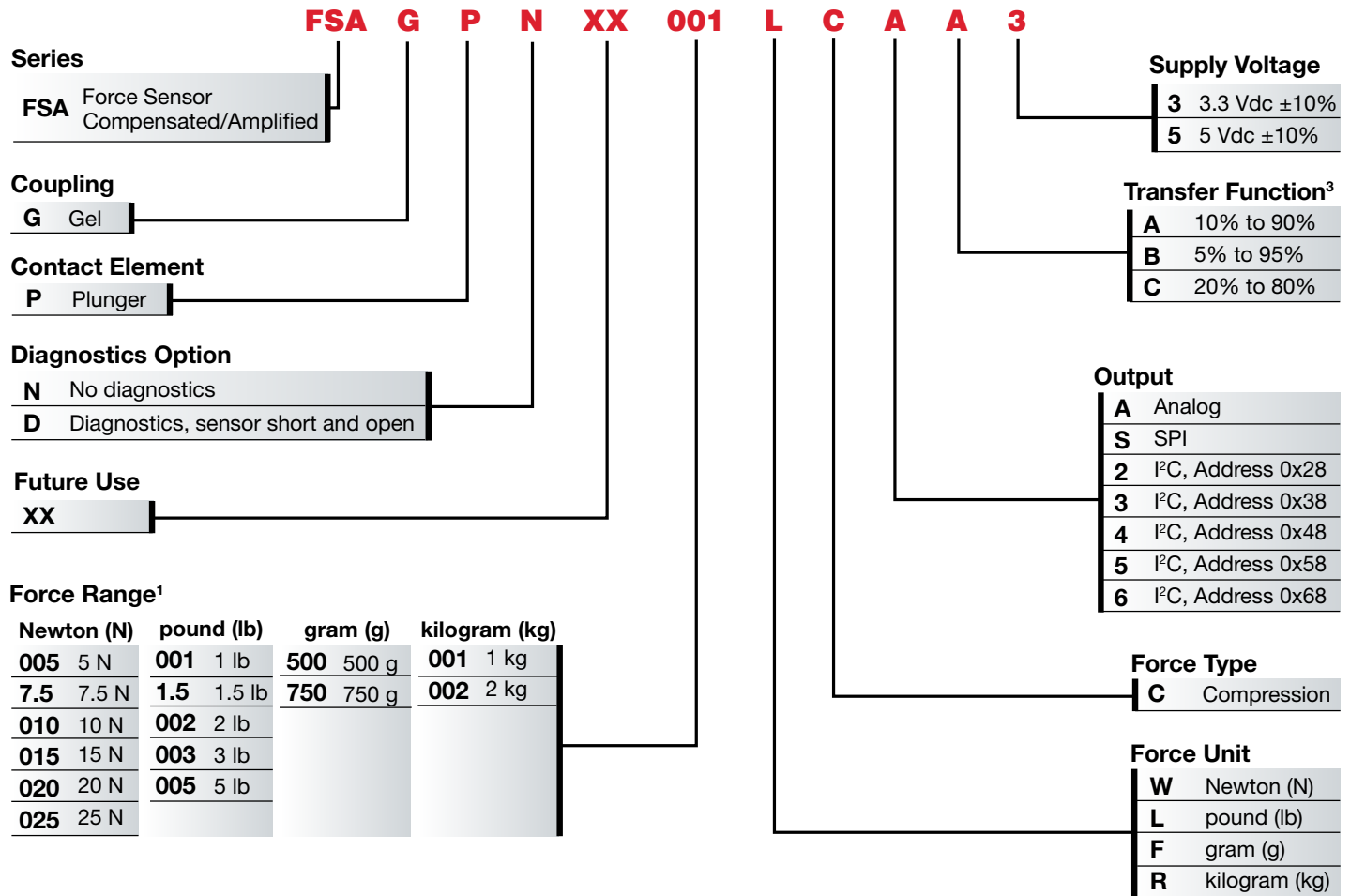

¹Custom designations available upon request.

²Consult with factory.

³For other available transfer functions, contact Honeywell customer service.

COMMON CATALOG LISTINGS

FSAGPDXX010WCAA5
 FSAGPDXX001RCAB5
 FSAGPNXX1.5LCAC5
 FSAGPNXX003LCAC5
 FSAGPNXX010WC2C3
 FSAGPNXX001RC4C5
 FSAGPDXX005LCSB5
 FSAGPDXX1.5LC5B5

Force Sensors, FSA Series Compensated/Amplified

Figure 2. Transfer Function Limits¹

Analog Version

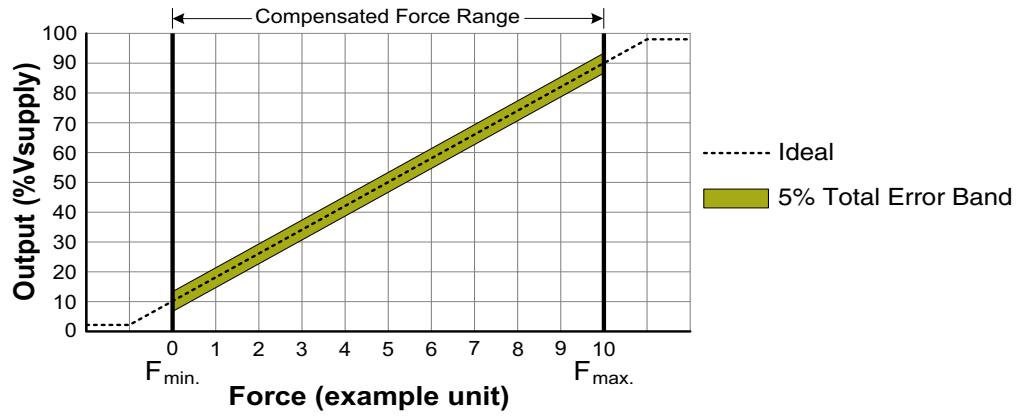

$$\text{Output (V)} = \frac{0.8 \times V_{\text{supply}}}{\text{Force}_{\text{range}}} \times (\text{Force}_{\text{applied}}) + 0.10 \times V_{\text{supply}}$$

Digital Version

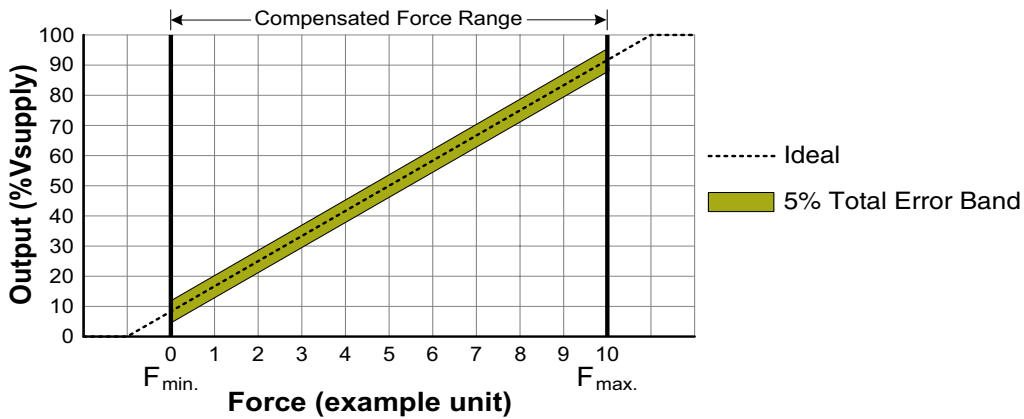

$$\text{Output (\% of } 2^{14} \text{ counts)} = \frac{80\%}{\text{Force}_{\text{range}}} \times (\text{Force}_{\text{applied}}) + 10\%$$

¹Transfer Function "A" is shown. See Figure 1 for other available transfer function options.

Force Sensors, FSA Series Compensated/Amplified

Figure 3. Mounting Dimensions (For reference only: mm/in.)

Analog version

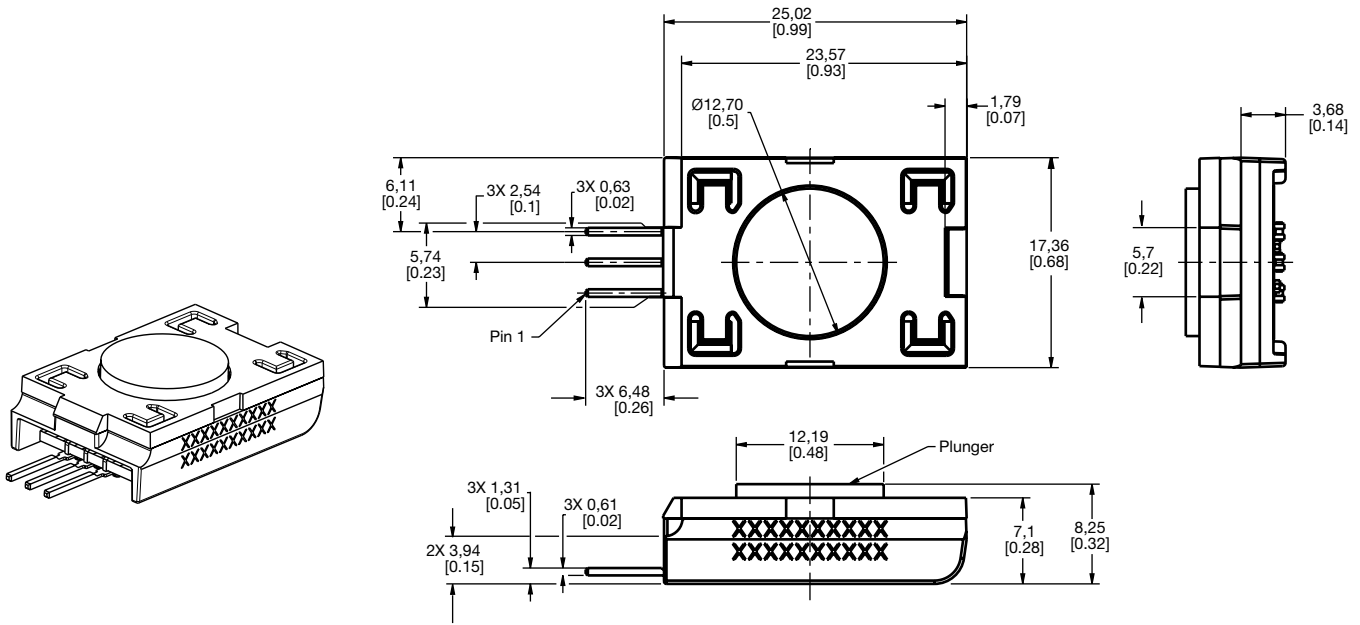

Function	Pin 1	Pin 2	Pin 3
analog	V_{supply}	Vout	GND

Digital version

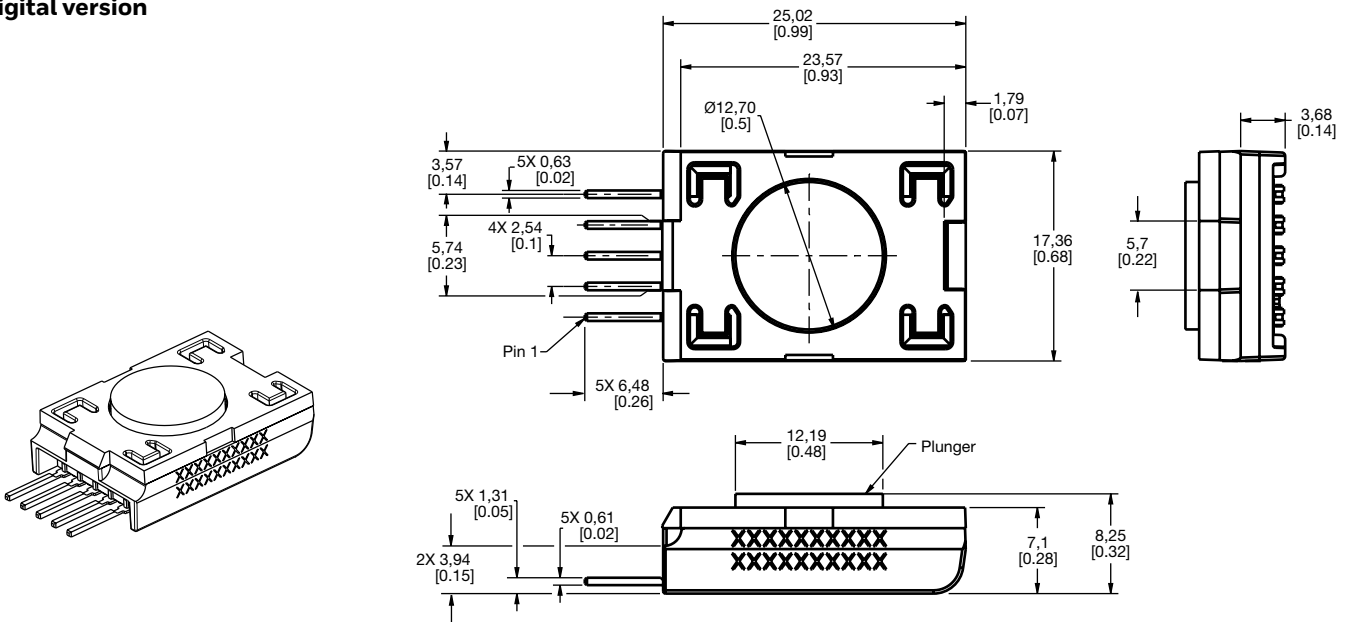

Function	Pin 1	Pin 2	Pin 3	Pin 4	Pin 5
SPI	GND	V_{supply}	SS	MISO	SCLK
I ² C	GND	V_{supply}	N/C	SDA	SCL

ADDITIONAL INFORMATION

The following associated literature is available on the Honeywell web site at sensing.honeywell.com:

- Product Range Guide
- Product Line Guide
- Product Installation Instructions
- Technical Information:
 - SPI Communications with Honeywell Digital Output Force Sensors
 - I²C Communications with Honeywell Digital Output Force Sensors

Find out more

Honeywell serves its customers through a worldwide network of sales offices and distributors. For application assistance, current specifications, pricing or name of the nearest Authorized Distributor, contact your local sales office.

To learn more about Honeywell's sensing and switching products, call **+1-815-235-6847** or **1-800-537-6945**, visit **sensing.honeywell.com**, or e-mail inquiries to **info.sc@honeywell.com**

Honeywell Sensing and Internet of Things

9680 Old Bailes Road
Fort Mill, SC 29707
honeywell.com

⚠ WARNING **PERSONAL INJURY**

DO NOT USE these products as safety or emergency stop devices or in any other application where failure of the product could result in personal injury.

Failure to comply with these instructions could result in death or serious injury.

⚠ WARNING **MISUSE OF DOCUMENTATION**

- The information presented in this datasheet is for reference only. Do not use this document as a product installation guide.
- Complete installation, operation, and maintenance information is provided in the instructions supplied with each product.

Failure to comply with these instructions could result in death or serious injury.

Warranty/Remedy

Honeywell warrants goods of its manufacture as being free of defective materials and faulty workmanship during the applicable warranty period. Honeywell's standard product warranty applies unless agreed to otherwise by Honeywell in writing; please refer to your order acknowledgment or consult your local sales office for specific warranty details. If warranted goods are returned to Honeywell during the period of coverage, Honeywell will repair or replace, at its option, without charge those items that Honeywell, in its sole discretion, finds defective. **The foregoing is buyer's sole remedy and is in lieu of all other warranties, expressed or implied, including those of merchantability and fitness for a particular purpose. In no event shall Honeywell be liable for consequential, special, or indirect damages.**

While Honeywell may provide application assistance personally, through our literature and the Honeywell web site, it is buyer's sole responsibility to determine the suitability of the product in the application.

Specifications may change without notice. The information we supply is believed to be accurate and reliable as of this writing. However, Honeywell assumes no responsibility for its use.

Honeywell