



Chipsmall Limited consists of a professional team with an average of over 10 year of expertise in the distribution of electronic components. Based in Hongkong, we have already established firm and mutual-benefit business relationships with customers from,Europe,America and south Asia,supplying obsolete and hard-to-find components to meet their specific needs.

With the principle of "Quality Parts,Customers Priority,Honest Operation,and Considerate Service",our business mainly focus on the distribution of electronic components. Line cards we deal with include Microchip,ALPS,ROHM,Xilinx,Pulse,ON,Everlight and Freescale. Main products comprise IC,Modules,Potentiometer,IC Socket,Relay,Connector.Our parts cover such applications as commercial,industrial, and automotives areas.

We are looking forward to setting up business relationship with you and hope to provide you with the best service and solution. Let us make a better world for our industry!



Contact us

Tel: +86-755-8981 8866 Fax: +86-755-8427 6832

Email & Skype: info@chipsmall.com Web: www.chipsmall.com

Address: A1208, Overseas Decoration Building, #122 Zhenhua RD., Futian, Shenzhen, China





Is Now Part of



ON Semiconductor®

To learn more about ON Semiconductor, please visit our website at
www.onsemi.com

Please note: As part of the Fairchild Semiconductor integration, some of the Fairchild orderable part numbers will need to change in order to meet ON Semiconductor's system requirements. Since the ON Semiconductor product management systems do not have the ability to manage part nomenclature that utilizes an underscore (_), the underscore (_) in the Fairchild part numbers will be changed to a dash (-). This document may contain device numbers with an underscore (_). Please check the ON Semiconductor website to verify the updated device numbers. The most current and up-to-date ordering information can be found at www.onsemi.com. Please email any questions regarding the system integration to Fairchild_questions@onsemi.com.

ON Semiconductor and the ON Semiconductor logo are trademarks of Semiconductor Components Industries, LLC dba ON Semiconductor or its subsidiaries in the United States and/or other countries. ON Semiconductor owns the rights to a number of patents, trademarks, copyrights, trade secrets, and other intellectual property. A listing of ON Semiconductor's product/patent coverage may be accessed at www.onsemi.com/site/pdf/Patent-Marking.pdf. ON Semiconductor reserves the right to make changes without further notice to any products herein. ON Semiconductor makes no warranty, representation or guarantee regarding the suitability of its products for any particular purpose, nor does ON Semiconductor assume any liability arising out of the application or use of any product or circuit, and specifically disclaims any and all liability, including without limitation special, consequential or incidental damages. Buyer is responsible for its products and applications using ON Semiconductor products, including compliance with all laws, regulations and safety requirements or standards, regardless of any support or applications information provided by ON Semiconductor. "Typical" parameters which may be provided in ON Semiconductor data sheets and/or specifications can and do vary in different applications and actual performance may vary over time. All operating parameters, including "Typicals" must be validated for each customer application by customer's technical experts. ON Semiconductor does not convey any license under its patent rights nor the rights of others. ON Semiconductor products are not designed, intended, or authorized for use as a critical component in life support systems or any FDA Class 3 medical devices or medical devices with a same or similar classification in a foreign jurisdiction or any devices intended for implantation in the human body. Should Buyer purchase or use ON Semiconductor products for any such unintended or unauthorized application, Buyer shall indemnify and hold ON Semiconductor and its officers, employees, subsidiaries, affiliates, and distributors harmless against all claims, costs, damages, and expenses, and reasonable attorney fees arising out of, directly or indirectly, any claim of personal injury or death associated with such unintended or unauthorized use, even if such claim alleges that ON Semiconductor was negligent regarding the design or manufacture of the part. ON Semiconductor is an Equal Opportunity/Affirmative Action Employer. This literature is subject to all applicable copyright laws and is not for resale in any manner.



FSAV330 — 4-Channel, 2:1 Video Switch

Features

- Replacement for the P15V330
- Wide Bandwidth: 300MHz
- 4Ω Switch Connection between Two Ports
- Minimal Propagation Delay through the Switch
- Low I_{cc}
- Zero Bounce in Flow-through Mode
- Control Inputs Compatible with TTL Level

Description

The FSAV330 video switch is a quad, single-pole / double-throw, high-speed CMOS TTL-compatible video switch. The low on resistance of the switch allows inputs to be connected to outputs without adding propagation delay or generating additional ground bounce noise.

When /OE is LOW, the select pin connects the A port to the selected B port output. When /OE is HIGH, the switch is OPEN and a high-impedance state exists between the two ports.

Applications

- Set-Top Boxes
- Flat Panel Displays
- CRT Displays
- DVD - RW

Ordering Information

Part Number	Operating Temperature Range	Package	Packing Method
FSAV330MX	-40 to +85°C	16-Lead, Small Outline Integrated Circuit (SOIC), JEDEC MS-012, 0.150 inch Narrow	Tape and Reel
FSAV330MTCX	-40 to +85°C	16-, Thin Shrink Small Outline Package (TSSOP), JEDEC MO-153, 4.4mm Wide	Tape and Reel
FSAV330QSCX	-40 to +85°C	16-Lead, Quarter Size Outline Package (QSOP), JEDEC MO-137, 0.150 inch Wide	Tape and Reel

The Fairchild switch family derives from and embodies Fairchild's proven switch technology used for several years in its 74LVX3L384 (FST3384) bus switch product.

Pin Configurations

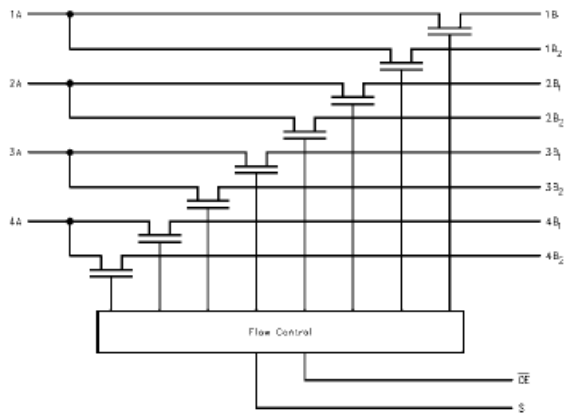

Figure 1. Logic Diagram

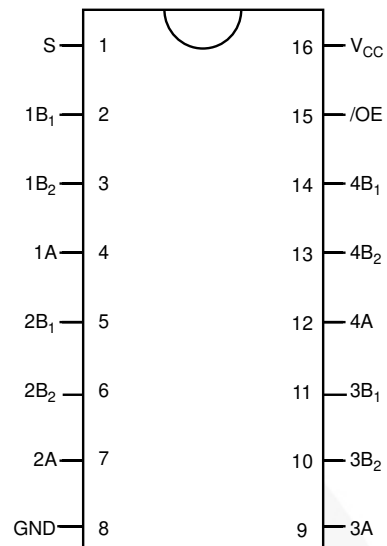

Figure 2. Pin Assignments

Pin Descriptions

Pin #	Name	Description
15	/OE	Bus Switch Enabled
1	S	Select Input
4,7,9,12	A	Bus A
2,3,5,6,10,11,13,14	B ₁ -B ₂	Bus B
8	GND	Ground
16	V _{CC}	Supply Voltage

Truth Table

S	/OE	Function
Don't Care	HIGH	Disconnected
LOW	LOW	A=B ₁
HIGH	LOW	A=B ₂

Absolute Maximum Ratings

Stresses exceeding the absolute maximum ratings may damage the device. The device may not function or be operable above the recommended operating conditions and stressing the parts to these levels is not recommended. In addition, extended exposure to stresses above the recommended operating conditions may affect device reliability. The absolute maximum ratings are stress ratings only.

Symbol	Parameter	Min.	Max.	Unit
V _{CC}	Supply Voltage	-0.5	+7.0	V
V _S	DC Switch Voltage	-0.5	+7.0	V
V _{IN}	DC Input Voltage ⁽¹⁾	-0.5	+7.0	V
I _{IK}	DC Input Diode Current	-50		mA
I _{OUT}	DC Output Sink Current		128	mA
I _{CC} /I _{GND}	DC V _{CC} / GND Current		±100	mA
T _{STG}	Storage Temperature Range	-65	+150	°C
ESD	Human Body Model, JESD22-A114		4000	V

Note:

- The input and output negative voltage ratings may be exceeded if the input and output diode current ratings are observed.

Recommended Operating Conditions

The Recommended Operating Conditions table defines the conditions for actual device operation. Recommended operating conditions are specified to ensure optimal performance to the datasheet specifications. Fairchild does not recommend exceeding them or designing to Absolute Maximum Ratings.

Symbol	Parameter	Min.	Max.	Unit	
V _{CC}	Power Supply	4.0	5.5	V	
V _{IN}	Input Voltage	0	5.5	V	
V _{OUT}	Output Voltage	0	5.5	V	
t _r , t _f	Input Rise and Fall Time	Switch Control Input	0	5	ns/V
		Switch I/O	0	DC	
T _A	Operating Temperature, Free Air	-40	+85	°C	

Note:

- Unused control inputs must be held HIGH or LOW; they may not float.

DC Electrical Characteristics

Typical values are at $V_{CC}=5.0V$ and $T_A=+25^{\circ}C$. Minimum and maximum values are at $T_A=-40$ to $+85^{\circ}C$.

Symbol	Parameter	Conditions	V_{CC} (V)	Min.	Typ.	Max.	Units
V_{ANALOG}	Analog Signal Range		5.0	0		2	V
V_{IK}	Clamp Diode Voltage	$I_{IN}=-18mA$	4.5			-1.2	V
V_{IH}	High-Level Input Voltage		4.0 to 5.5	2.0			V
V_{IL}	Low-Level Input Voltage		4.0 to 5.5			0.8	V
I_I	Input Leakage Current	$0 \leq V_{IN} \leq 5.5V$	5.5			± 1.0	μA
I_{OZ}	Off-State Leakage Current	$0 \leq A, B \leq V_{CC}$	5.5			± 1.0	μA
R_{ON}	Switch On Resistance ⁽³⁾	$V_{IN}=1.0V, R_I=75\Omega, I_{ON}=13mA$	4.5		3	7	Ω
		$V_{IN}=2.0V, R_I=75\Omega, I_{ON}=26mA$	4.5		7	10	
I_{CC}	Quiescent Supply Current	$V_{IN}=V_{CC}$ or GND, $I_{OUT}=0$	5.5			3	μA
ΔI_{CC}	Increase in I_{CC} per Input	One Input at 3.4V Other Inputs at V_{CC} or GND	5.5			2.5	mA

Note:

3. Measured by the voltage drop between the A and B pins at the indicated current through the switch. On resistance is determined by the lower of the voltages on the A or B pins.

AC Electrical Characteristics

$T_A=-40$ to $+85^{\circ}C$, $C_L=50pF$, $R_U=R_D=500\Omega$.

Symbol	Parameter	Conditions	$V_{CC}=4.5 - 5.5V$			$V_{CC}=4.0V$		Units	Figure
			Min.	Typ.	Max.	Min.	Max.		
t_{PZH}, t_{PZL}	Output Enable Time, Select to Bus B	$V_I=7V$ for t_{PZL} $V_I=Open$ for t_{PZH}			5.2		5.7	ns	Figure 3 Figure 4
	Output Enable Time, /OE to Bus A, B				5.1		5.6		
t_{PHZ}, t_{PLZ}	Output Disable Time, Select to Bus B	$V_I=7V$ for t_{PLZ} $V_I=Open$ for t_{PHZ}			5.2		5.5	ns	Figure 3 Figure 4
	Output Disable Time, Output Enable Time /OE to Bus A, B				5.5		5.5		
BW	-3dB Bandwidth ⁽⁴⁾	$R_L=150\Omega, T_A=25^{\circ}C$	300					MHz	
X_{TALK}	Crosstalk	$R_{IN}=10\Omega,$ $R_L=150\Omega, f=10MHz$		-58				dB	
D_G	Differential Gain	$R_L=150\Omega,$ $f=3.58MHz$		0.64				%	
D_P	Differential Phase	$R_L=150\Omega,$ $f=3.58MHz$		0.1				$^{\circ}$	
O_{IRR}	Off Isolation	$R_L=150\Omega, f=10MHz$		-60				dB	

Note:

4. This parameter is guaranteed by device characterization, not production tested.

Capacitance

$T_A=+25^{\circ}C$, $f=1MHz$. Capacitance is characterized, not production tested.

Symbol	Parameter	Conditions	Typ.	Units
C_{IN}	Control Pin Input Capacitance	$V_{CC}=5.0V$	3	pF
$C_{I/O}$	A Port	$V_{CC}, /OE=5.0V$	7	pF
	B Port		5	
C_{ON}	Switch On Capacitance	$V_{CC}=5.0V, /OE=0V$	12	pF

AC Loadings and Waveforms

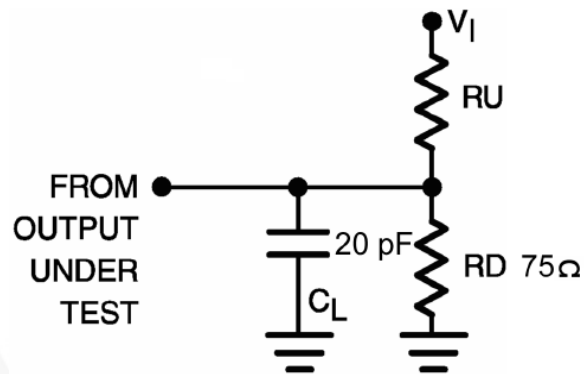

Notes:

5. Input drive by 50Ω source terminated in 50Ω .
6. C_L includes load and stray capacitance.
7. Input PRR=1.0MHz, $t_w=500\text{ns}$.

Figure 3. AC Test Circuit

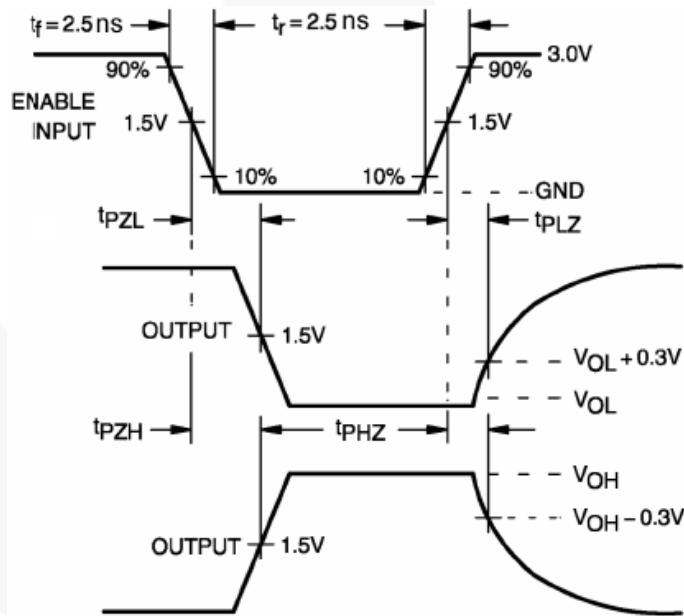

Figure 4. AC Waveforms

Physical Dimensions

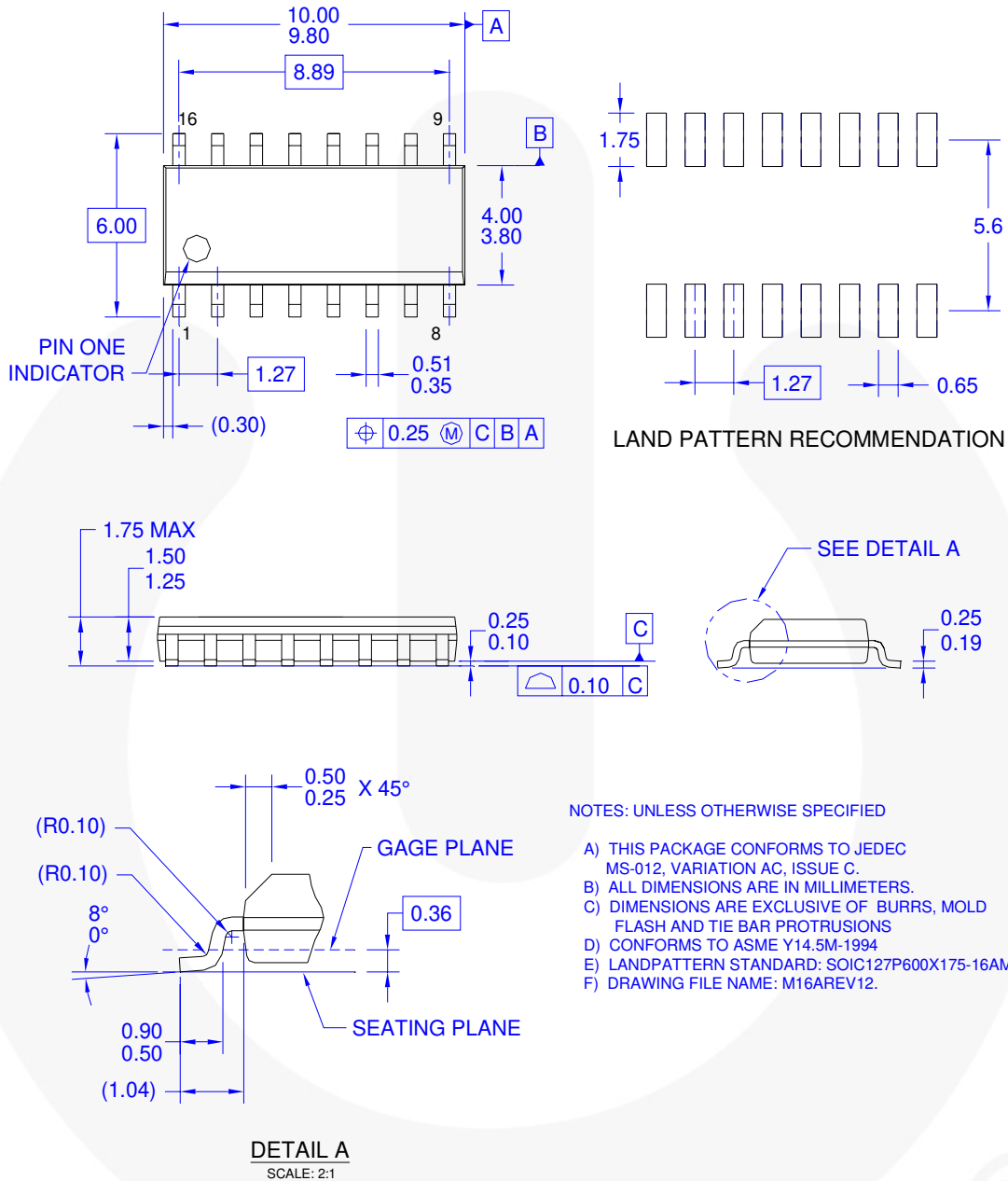
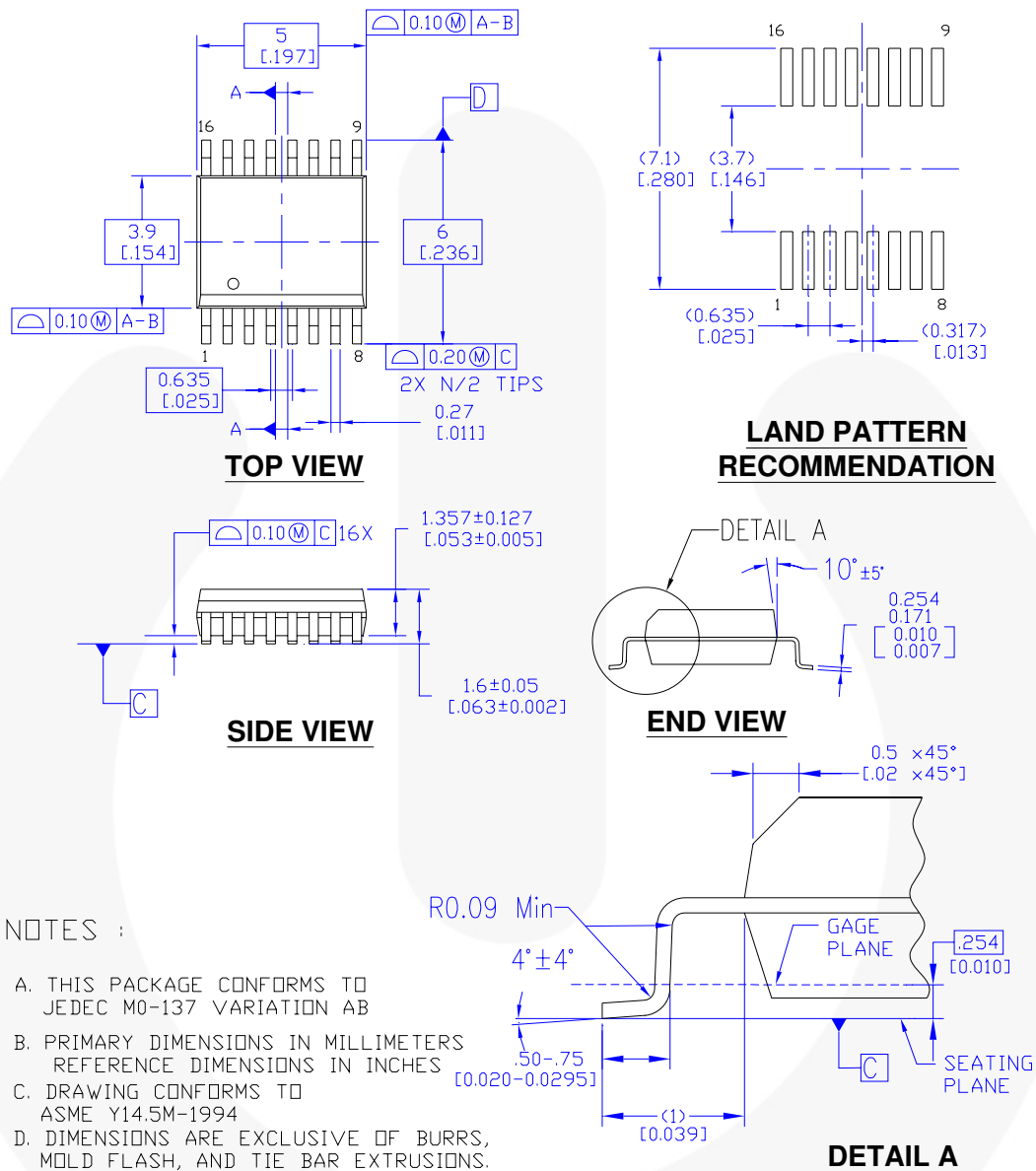

Figure 5. 16-Lead, Small Outline Integrated Circuit (SOIC), JEDEC MS-012, 0.150-inch Narrow

Package drawings are provided as a service to customers considering Fairchild components. Drawings may change in any manner without notice. Please note the revision and/or date on the drawing and contact a Fairchild Semiconductor representative to verify or obtain the most recent revision. Package specifications do not expand the terms of Fairchild's worldwide terms and conditions, specifically the warranty therein, which covers Fairchild products.

Always visit Fairchild Semiconductor's online packaging area for the most recent package drawings:
<http://www.fairchildsemi.com/packaging/>

Physical Dimensions



MQA16AREVB

Figure 6. 16-Lead, Quarter Size Outline Package (QSOP), JEDEC MO-137, 0.150-inch Wide

Package drawings are provided as a service to customers considering Fairchild components. Drawings may change in any manner without notice. Please note the revision and/or date on the drawing and contact a Fairchild Semiconductor representative to verify or obtain the most recent revision. Package specifications do not expand the terms of Fairchild's worldwide terms and conditions, specifically the warranty therein, which covers Fairchild products.

Always visit Fairchild Semiconductor's online packaging area for the most recent package drawings:
<http://www.fairchildsemi.com/packaging/>

Physical Dimensions

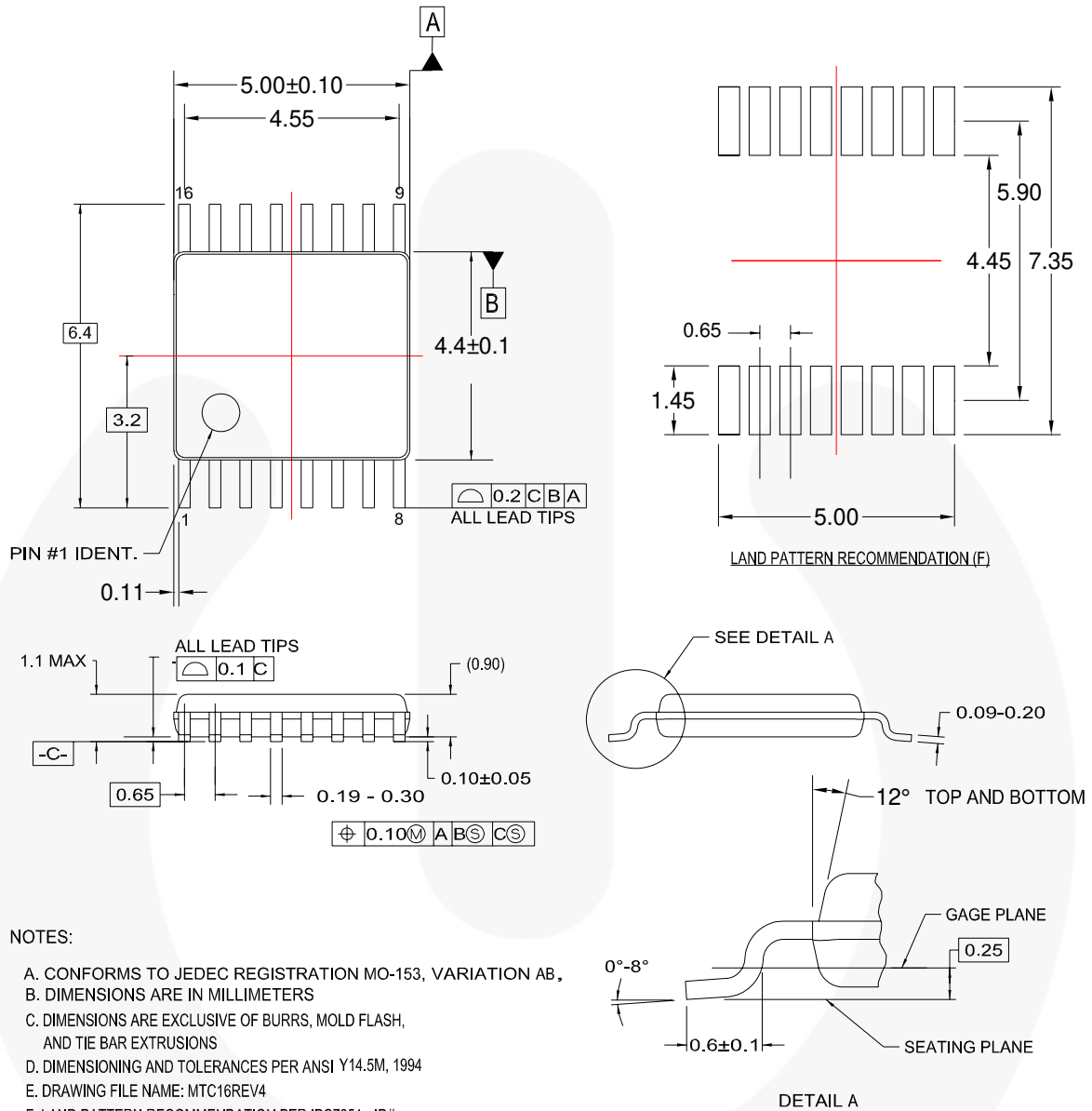

MTC16rev4

Figure 7. 16-Lead, Thin Shrink Small Outline Package (TSSOP), JEDEC MO-153, 4.4mm Wide







Package drawings are provided as a service to customers considering Fairchild components. Drawings may change in any manner without notice. Please note the revision and/or date on the drawing and contact a Fairchild Semiconductor representative to verify or obtain the most recent revision. Package specifications do not expand the terms of Fairchild's worldwide terms and conditions, specifically the warranty therein, which covers Fairchild products.

Always visit Fairchild Semiconductor's online packaging area for the most recent package drawings:
<http://www.fairchildsemi.com/packaging/>



TRADEMARKS

The following includes registered and unregistered trademarks and service marks, owned by Fairchild Semiconductor and/or its global subsidiaries, and is not intended to be an exhaustive list of all such trademarks.

- | | | | |
|--|--|--|---|
| AccuPower™ | F-PFST™ | Power-SPM™ |  SYSTEM GENERAL |
| Auto-SPM™ | FRFET® | PowerTrench® | The Power Franchise® |
| Build it Now™ | Global Power Resource SM | PowerXS™ |  the power franchise |
| CorePLUS™ | Green FPST™ | Programmable Active Droop™ | TinyBoost™ |
| CorePOWER™ | Green FPST™ e-Series™ | QFET® | TinyBuck™ |
| CROSSVOLT™ | Gmax™ | QS™ | TinyCalc™ |
| CTL™ | GTO™ | Quiet Series™ | TinyLogic® |
| Current Transfer Logic™ | IntelliMAX™ | RapidConfigure™ | TINYOPTO™ |
| DEUXPEED® | ISOPLANAR™ |  TM | TinyPower™ |
| Dual Cool™ | MegaBuck™ | Saving our world, 1mW/W/kW at a time™ | TinyPVM™ |
| EcoSPARK® | MICROCOUPLER™ | SignalWise™ | TinyWire™ |
| EfficientMax™ | MicroFET™ | SmartMax™ | TriFault Detect™ |
| ESBC™ | MicroPak™ | SMART START™ | TRUECURRENT™* |
|  Fairchild® | MicroPak2™ | SPM® | μSerDes™ |
| Fairchild Semiconductor® | MillerDrive™ | STEALTH™ |  SerDes |
| FACT Quiet Series™ | MotionMax™ | SuperFET® | UHC® |
| FACT™ | Motion-SPM™ | SuperSOT™.3 | Ultra FRFET™ |
| FAST® | OptoHIT™ | SuperSOT™.6 | UniFET™ |
| FastvCore™ | OPTOLOGIC® | SuperSOT™.8 | VCX™ |
| FETBench™ | OPTOPLANAR® | SupreMOS® | VisualMax™ |
| FlashWriter® |  PDP SPM™ | SyncFET™ | XS™ |
| FPS™ | | Sync-Lock™ | |

* Trademarks of System General Corporation, used under license by Fairchild Semiconductor.

DISCLAIMER

FAIRCHILD SEMICONDUCTOR RESERVES THE RIGHT TO MAKE CHANGES WITHOUT FURTHER NOTICE TO ANY PRODUCTS HEREIN TO IMPROVE RELIABILITY, FUNCTION, OR DESIGN. FAIRCHILD DOES NOT ASSUME ANY LIABILITY ARISING OUT OF THE APPLICATION OR USE OF ANY PRODUCT OR CIRCUIT DESCRIBED HEREIN; NEITHER DOES IT CONVEY ANY LICENSE UNDER ITS PATENT RIGHTS, NOR THE RIGHTS OF OTHERS. THESE SPECIFICATIONS DO NOT EXPAND THE TERMS OF FAIRCHILD'S WORLDWIDE TERMS AND CONDITIONS, SPECIFICALLY THE WARRANTY THEREIN, WHICH COVERS THESE PRODUCTS.

LIFE SUPPORT POLICY

FAIRCHILD'S PRODUCTS ARE NOT AUTHORIZED FOR USE AS CRITICAL COMPONENTS IN LIFE SUPPORT DEVICES OR SYSTEMS WITHOUT THE EXPRESS WRITTEN APPROVAL OF FAIRCHILD SEMICONDUCTOR CORPORATION.

As used herein:

1. Life support devices or systems are devices or systems which, (a) are intended for surgical implant into the body or (b) support or sustain life, and (c) whose failure to perform when properly used in accordance with instructions for use provided in the labeling, can be reasonably expected to result in a significant injury of the user.
2. A critical component in any component of a life support, device, or system whose failure to perform can be reasonably expected to cause the failure of the life support device or system, or to affect its safety or effectiveness.

ANTI-COUNTERFEITING POLICY

Fairchild Semiconductor Corporation's Anti-Counterfeiting Policy. Fairchild's Anti-Counterfeiting Policy is also stated on our external website, www.fairchildsemi.com, under Sales Support.

Counterfeiting of semiconductor parts is a growing problem in the industry. All manufacturers of semiconductor products are experiencing counterfeiting of their parts. Customers who inadvertently purchase counterfeit parts experience many problems such as loss of brand reputation, substandard performance, failed applications, and increased cost of production and manufacturing delays. Fairchild is taking strong measures to protect ourselves and our customers from the proliferation of counterfeit parts. Fairchild strongly encourages customers to purchase Fairchild parts either directly from Fairchild or from Authorized Fairchild Distributors who are listed by country on our web page cited above. Products customers buy either from Fairchild directly or from Authorized Fairchild Distributors are genuine parts, have full traceability, meet Fairchild's quality standards for handling and storage and provide access to Fairchild's full range of up-to-date technical and product information. Fairchild and our Authorized Distributors will stand behind all warranties and will appropriately address any warranty issues that may arise. Fairchild will not provide any warranty coverage or other assistance for parts bought from Unauthorized Sources. Fairchild is committed to combat this global problem and encourage our customers to do their part in stopping this practice by buying direct or from authorized distributors.

PRODUCT STATUS DEFINITIONS

Definition of Terms

Datasheet Identification	Product Status	Definition
Advance Information	Formative / In Design	Datasheet contains the design specifications for product development. Specifications may change in any manner without notice.
Preliminary	First Production	Datasheet contains preliminary data; supplementary data will be published at a later date. Fairchild Semiconductor reserves the right to make changes at any time without notice to improve design.
No Identification Needed	Full Production	Datasheet contains final specifications. Fairchild Semiconductor reserves the right to make changes at any time without notice to improve the design.
Obsolete	Not In Production	Datasheet contains specifications on a product that is discontinued by Fairchild Semiconductor. The datasheet is for reference information only.

Rev. 150

ON Semiconductor and  are trademarks of Semiconductor Components Industries, LLC dba ON Semiconductor or its subsidiaries in the United States and/or other countries. ON Semiconductor owns the rights to a number of patents, trademarks, copyrights, trade secrets, and other intellectual property. A listing of ON Semiconductor's product/patent coverage may be accessed at www.onsemi.com/site/pdf/Patent-Marking.pdf. ON Semiconductor reserves the right to make changes without further notice to any products herein. ON Semiconductor makes no warranty, representation or guarantee regarding the suitability of its products for any particular purpose, nor does ON Semiconductor assume any liability arising out of the application or use of any product or circuit, and specifically disclaims any and all liability, including without limitation special, consequential or incidental damages. Buyer is responsible for its products and applications using ON Semiconductor products, including compliance with all laws, regulations and safety requirements or standards, regardless of any support or applications information provided by ON Semiconductor. "Typical" parameters which may be provided in ON Semiconductor data sheets and/or specifications can and do vary in different applications and actual performance may vary over time. All operating parameters, including "Typicals" must be validated for each customer application by customer's technical experts. ON Semiconductor does not convey any license under its patent rights nor the rights of others. ON Semiconductor products are not designed, intended, or authorized for use as a critical component in life support systems or any FDA Class 3 medical devices or medical devices with a same or similar classification in a foreign jurisdiction or any devices intended for implantation in the human body. Should Buyer purchase or use ON Semiconductor products for any such unintended or unauthorized application, Buyer shall indemnify and hold ON Semiconductor and its officers, employees, subsidiaries, affiliates, and distributors harmless against all claims, costs, damages, and expenses, and reasonable attorney fees arising out of, directly or indirectly, any claim of personal injury or death associated with such unintended or unauthorized use, even if such claim alleges that ON Semiconductor was negligent regarding the design or manufacture of the part. ON Semiconductor is an Equal Opportunity/Affirmative Action Employer. This literature is subject to all applicable copyright laws and is not for resale in any manner.

PUBLICATION ORDERING INFORMATION

LITERATURE FULFILLMENT:

Literature Distribution Center for ON Semiconductor
19521 E. 32nd Pkwy, Aurora, Colorado 80011 USA
Phone: 303-675-2175 or 800-344-3860 Toll Free USA/Canada
Fax: 303-675-2176 or 800-344-3867 Toll Free USA/Canada
Email: orderlit@onsemi.com

N. American Technical Support: 800-282-9855 Toll Free
USA/Canada
Europe, Middle East and Africa Technical Support:
Phone: 421 33 790 2910
Japan Customer Focus Center
Phone: 81-3-5817-1050

ON Semiconductor Website: www.onsemi.com
Order Literature: <http://www.onsemi.com/orderlit>
For additional information, please contact your local
Sales Representative