



Chipsmall Limited consists of a professional team with an average of over 10 year of expertise in the distribution of electronic components. Based in Hongkong, we have already established firm and mutual-benefit business relationships with customers from,Europe,America and south Asia,supplying obsolete and hard-to-find components to meet their specific needs.

With the principle of "Quality Parts,Customers Priority,Honest Operation,and Considerate Service",our business mainly focus on the distribution of electronic components. Line cards we deal with include Microchip,ALPS,ROHM,Xilinx,Pulse,ON,Everlight and Freescale. Main products comprise IC,Modules,Potentiometer,IC Socket,Relay,Connector.Our parts cover such applications as commercial,industrial, and automotives areas.

We are looking forward to setting up business relationship with you and hope to provide you with the best service and solution. Let us make a better world for our industry!



## Contact us

Tel: +86-755-8981 8866 Fax: +86-755-8427 6832

Email & Skype: info@chipsmall.com Web: www.chipsmall.com

Address: A1208, Overseas Decoration Building, #122 Zhenhua RD., Futian, Shenzhen, China





Is Now Part of



**ON Semiconductor®**

To learn more about ON Semiconductor, please visit our website at  
[www.onsemi.com](http://www.onsemi.com)

ON Semiconductor and the ON Semiconductor logo are trademarks of Semiconductor Components Industries, LLC dba ON Semiconductor or its subsidiaries in the United States and/or other countries. ON Semiconductor owns the rights to a number of patents, trademarks, copyrights, trade secrets, and other intellectual property. A listing of ON Semiconductor's product/patent coverage may be accessed at [www.onsemi.com/site/pdf/Patent-Marking.pdf](http://www.onsemi.com/site/pdf/Patent-Marking.pdf). ON Semiconductor reserves the right to make changes without further notice to any products herein. ON Semiconductor makes no warranty, representation or guarantee regarding the suitability of its products for any particular purpose, nor does ON Semiconductor assume any liability arising out of the application or use of any product or circuit, and specifically disclaims any and all liability, including without limitation special, consequential or incidental damages. Buyer is responsible for its products and applications using ON Semiconductor products, including compliance with all laws, regulations and safety requirements or standards, regardless of any support or applications information provided by ON Semiconductor. "Typical" parameters which may be provided in ON Semiconductor data sheets and/or specifications can and do vary in different applications and actual performance may vary over time. All operating parameters, including "Typicals" must be validated for each customer application by customer's technical experts. ON Semiconductor does not convey any license under its patent rights nor the rights of others. ON Semiconductor products are not designed, intended, or authorized for use as a critical component in life support systems or any FDA Class 3 medical devices or medical devices with a same or similar classification in a foreign jurisdiction or any devices intended for implantation in the human body. Should Buyer purchase or use ON Semiconductor products for any such unintended or unauthorized application, Buyer shall indemnify and hold ON Semiconductor and its officers, employees, subsidiaries, affiliates, and distributors harmless against all claims, costs, damages, and expenses, and reasonable attorney fees arising out of, directly or indirectly, any claim of personal injury or death associated with such unintended or unauthorized use, even if such claim alleges that ON Semiconductor was negligent regarding the design or manufacture of the part. ON Semiconductor is an Equal Opportunity/Affirmative Action Employer. This literature is subject to all applicable copyright laws and is not for resale in any manner.



ON Semiconductor®

February 2017

# FSB50450BS

## Motion SPM® 5 Series

### Features

- UL Certified No. E209204 (UL1557)
- Optimized for over 10 kHz Switching Frequency
- 500 V FRFET MOSFET 3-Phase Inverter with Gate Drivers and Protection
- Built-In Bootstrap Diodes Simplify PCB Layout
- Separate Open-Source Pins from Low-Side MOSFETs for Three-Phase Current-Sensing
- Active-HIGH Interface, Works with 3.3 / 5 V Logic, Schmitt-trigger Input
- Optimized for Low Electromagnetic Interference
- HVIC Temperature-Sensing Built-In for Temperature Monitoring
- HVIC for Gate Driving and Under-Voltage Protection
- Isolation Rating: 1500 V<sub>rms</sub> / min.
- RoHS Compliant
- Moisture Sensitive Level (MSL) 3 for SMD PKG

### Applications

- 3-Phase Inverter Driver for Small Power AC Motor Drives

### Related Source

- [RD-FSB50450AS - Reference Design for Motion SPM 5 Series Ver.2](#)
- [AN-9082 - Motion SPM5 Series Thermal Performance by Contact Pressure](#)

### General Description

The FSB50450BS is an advanced Motion SPM® 5 module providing a fully-featured, high-performance inverter output stage for AC Induction, BLDC and PMSM motors. These modules integrate optimized gate drive of the built-in MOSFETs (FRFET® technology) to minimize EMI and losses, while also providing multiple on-module protection features including under-voltage lockouts and thermal monitoring. The built-in high-speed HVIC requires only a single supply voltage and translates the incoming logic-level gate inputs to the high-voltage, high-current drive signals required to properly drive the module's internal MOSFETs. Separate open-source MOSFET terminals are available for each phase to support the widest variety of control algorithms.



Figure 1. 3D Package Drawing (Click to Activate 3D Content)

### Package Marking & Ordering Information

Device	Device Marking	Package	Packing Type	Reel Size	Quantity
FSB50550BS	FSB50450BS	SPM5Q-023	Tape & Reel	330mm	450

## Absolute Maximum Ratings

**Inverter Part** (each MOSFET unless otherwise specified.)

Symbol	Parameter	Conditions	Rating	Unit
$V_{DSS}$	Drain-Source Voltage of Each MOSFET		500	V
* $I_{D25}$	Each MOSFET Drain Current, Continuous	$T_C = 25^\circ\text{C}$	2.2	A
* $I_{D80}$	Each MOSFET Drain Current, Continuous	$T_C = 80^\circ\text{C}$	1.4	A
* $I_{DP}$	Each MOSFET Drain Current, Peak	$T_C = 25^\circ\text{C}$ , $PW < 100 \mu\text{s}$	5.0	A
* $I_{DRMS}$	Each MOSFET Drain Current, Rms	$T_C = 80^\circ\text{C}$ , $F_{PWM} < 20 \text{ kHz}$	1.0	$A_{rms}$

**Control Part** (each HVIC unless otherwise specified.)

Symbol	Parameter	Conditions	Rating	Unit
$V_{DD}$	Control Supply Voltage	Applied between $V_{DD}$ and COM	20	V
$V_{BS}$	High-side Bias Voltage	Applied between $V_B$ and $V_S$	20	V
$V_{IN}$	Input Signal Voltage	Applied between $V_{IN}$ and COM	$-0.3 \sim V_{DD} + 0.3$	V

**Bootstrap Diode Part** (each bootstrap diode unless otherwise specified.)

Symbol	Parameter	Conditions	Rating	Unit
$V_{RRMB}$	Maximum Repetitive Reverse Voltage		500	V
* $I_{FB}$	Forward Current	$T_C = 25^\circ\text{C}$	0.5	A
* $I_{FPB}$	Forward Current (Peak)	$T_C = 25^\circ\text{C}$ , Under 1ms Pulse Width	2.0	A

## Thermal Resistance

Symbol	Parameter	Conditions	Rating	Unit
$R_{th(j-c)Q}$	Junction to Case Thermal Resistance ( Note1 )	Inverter MOSFET part, (Per Module)	2.3	$^\circ\text{C/W}$

## Total System

Symbol	Parameter	Conditions	Rating	Unit
$T_J$	Operating Junction Temperature		$-40 \sim 150$	$^\circ\text{C}$
$T_{STG}$	Storage Temperature		$-40 \sim 125$	$^\circ\text{C}$
$V_{ISO}$	Isolation Voltage	60 Hz, Sinusoidal, 1 Minute, Connect Pins to Heat Sink Plate	1500	$V_{rms}$

### Notes:

- For the measurement point of case temperature  $T_C$ , please refer to Figure 4.
- Marking "\*" is calculation value or design factor.

### Pin descriptions

Pin Number	Pin Name	Pin Description
1	COM	IC Common Supply Ground
2	$V_{B(U)}$	Bias Voltage for U-Phase High-Side MOSFET Driving
3	$V_{DD(U)}$	Bias Voltage for U-Phase IC and Low-Side MOSFET Driving
4	$IN_{(UH)}$	Signal Input for U-Phase High-Side
5	$IN_{(UL)}$	Signal Input for U-Phase Low-Side
6	N.C	No Connection
7	$V_{B(V)}$	Bias Voltage for V-Phase High Side MOSFET Driving
8	$V_{DD(V)}$	Bias Voltage for V-Phase IC and Low Side MOSFET Driving
9	$IN_{(VH)}$	Signal Input for V-Phase High-Side
10	$IN_{(VL)}$	Signal Input for V-Phase Low-Side
11	$V_{TS}$	Output for HVIC Temperature Sensing
12	$V_{B(W)}$	Bias Voltage for W-Phase High-Side MOSFET Driving
13	$V_{DD(W)}$	Bias Voltage for W-Phase IC and Low-Side MOSFET Driving
14	$IN_{(WH)}$	Signal Input for W-Phase High-Side
15	$IN_{(WL)}$	Signal Input for W-Phase Low-Side
16	N.C	No Connection
17	P	Positive DC-Link Input
18	U, $V_{S(U)}$	Output for U-Phase & Bias Voltage Ground for High-Side MOSFET Driving
19	$N_U$	Negative DC-Link Input for U-Phase
20	$N_V$	Negative DC-Link Input for V-Phase
21	V, $V_{S(V)}$	Output for V-Phase & Bias Voltage Ground for High-Side MOSFET Driving
22	$N_W$	Negative DC-Link Input for W-Phase
23	W, $V_{S(W)}$	Output for W Phase & Bias Voltage Ground for High-Side MOSFET Driving

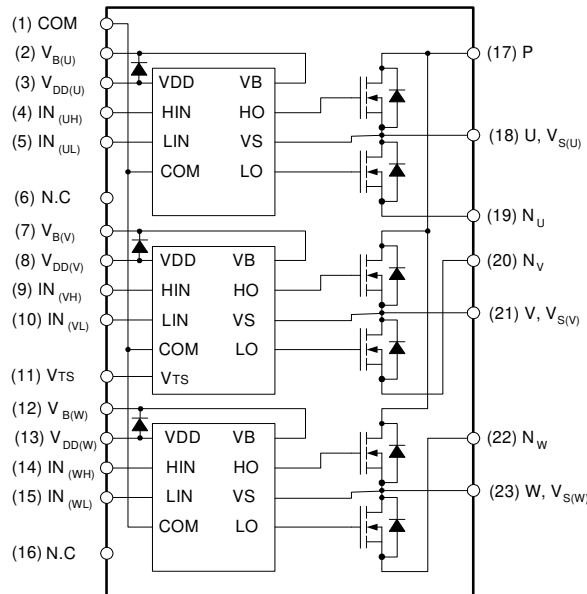

**Figure 2. Pin Configuration and Internal Block Diagram (Bottom View)**

**Notes:**

3. Source terminal of each low-side MOSFET is not connected to supply ground or bias voltage ground inside Motion SPM® 5 product. External connections should be made as indicated in Figure 3.

**Electrical Characteristics** ( $T_J = 25^\circ\text{C}$ ,  $V_{DD} = V_{BS} = 15\text{ V}$  unless otherwise specified.)

**Inverter Part** (each MOSFET unless otherwise specified.)

Symbol	Parameter	Conditions	Min	Typ	Max	Unit
$BV_{DSS}$	Drain - Source Breakdown Voltage	$V_{IN} = 0\text{ V}$ , $I_D = 1\text{ mA}$ ( Note 4)	500	-	-	V
$I_{DSS}$	Zero Gate Voltage Drain Current	$V_{IN} = 0\text{ V}$ , $V_{DS} = 500\text{ V}$	-	-	1	mA
$R_{DS(on)}$	Static Drain - Source Turn-On Resistance	$V_{DD} = V_{BS} = 15\text{ V}$ , $V_{IN} = 5\text{ V}$ , $I_D = 1.0\text{ A}$	-	4.3	5.3	$\Omega$
$V_{SD}$	Drain - Source Diode Forward Voltage	$V_{DD} = V_{BS} = 15\text{ V}$ , $V_{IN} = 0\text{ V}$ , $I_D = -1.0\text{ A}$	-	-	1.3	V
$t_{ON}$	Switching Times	$V_{PN} = 300\text{ V}$ , $V_{DD} = V_{BS} = 15\text{ V}$ , $I_D = 1.0\text{ A}$ $V_{IN} = 0\text{ V} \leftrightarrow 5\text{ V}$ , Inductive Load $L = 3\text{ mH}$ High- and Low-Side MOSFET Switching ( Note 5)	-	450	-	ns
$t_{OFF}$			-	500	-	ns
$t_{rr}$			-	70	-	ns
$E_{ON}$			-	25	-	$\mu\text{J}$
$E_{OFF}$			-	5	-	$\mu\text{J}$
RBSOA	Reverse Bias Safe Operating Area	$V_{PN} = 400\text{ V}$ , $V_{DD} = V_{BS} = 15\text{ V}$ , $I_D = I_{DP}$ , $V_{DS} = BV_{DSS}$ , $T_J = 150^\circ\text{C}$ High- and Low-Side MOSFET Switching ( Note 6)	Full Square			

**Control Part** (each HVIC unless otherwise specified.)

Symbol	Parameter	Conditions	Min	Typ	Max	Unit
$I_{QDD}$	Quiescent $V_{DD}$ Current	$V_{DD} = 15\text{ V}$ , $V_{IN} = 0\text{ V}$ Applied between $V_{DD}$ and COM	-	-	200	$\mu\text{A}$
$I_{QBS}$	Quiescent $V_{BS}$ Current	$V_{BS} = 15\text{ V}$ , $V_{IN} = 0\text{ V}$ Applied between $V_{B(U)} - U$ , $V_{B(V)} - V$ , $V_{B(W)} - W$	-	-	100	$\mu\text{A}$
$I_{PDD}$	Operating $V_{DD}$ Supply Current	$V_{DD} - \text{COM}$ $V_{DD} = 15\text{ V}$ , $f_{PWM} = 20\text{ kHz}$ , duty = 50%, Applied to One PWM Signal Input for Low-Side	-	-	900	$\mu\text{A}$
$I_{PBS}$	Operating $V_{BS}$ Supply Current	$V_{B(U)} - V_{S(U)}$ , $V_{B(V)} - V_{S(V)}$ , $V_{B(W)} - V_{S(W)}$ $V_{DD} = V_{BS} = 15\text{ V}$ , $f_{PWM} = 20\text{ kHz}$ , Duty = 50%, Applied to One PWM Signal Input for High-Side	-	-	800	$\mu\text{A}$
$UV_{DDD}$	Low-Side Under-Voltage Protection (Figure 8)	$V_{DD}$ Under-Voltage Protection Detection Level	7.4	8.0	9.4	V
$UV_{DDR}$		$V_{DD}$ Under-Voltage Protection Reset Level	8.0	8.9	9.8	V
$UV_{BSD}$	High-Side Under-Voltage Protection (Figure 9)	$V_{BS}$ Under-Voltage Protection Detection Level	7.4	8.0	9.4	V
$UV_{BSR}$		$V_{BS}$ Under-Voltage Protection Reset Level	8.0	8.9	9.8	V
$V_{TS}$	HVIC Temperature Sensing Voltage Output	$V_{DD} = 15\text{ V}$ , $T_{HVIC} = 25^\circ\text{C}$ ( Note 7)	600	790	980	mV
$V_{IH}$	ON Threshold Voltage	Logic HIGH Level	-	-	2.9	V
$V_{IL}$	OFF Threshold Voltage	Logic LOW Level	0.8	-	-	V

**Bootstrap Diode Part** (each bootstrap diode unless otherwise specified.)

Symbol	Parameter	Conditions	Min	Typ	Max	Unit
$V_{FB}$	Forward Voltage	$I_F = 0.1\text{ A}$ , $T_C = 25^\circ\text{C}$ ( Note 8)	-	2.5	-	V
$t_{rrB}$	Reverse Recovery Time	$I_F = 0.1\text{ A}$ , $T_C = 25^\circ\text{C}$	-	80	-	ns

## Recommended Operating Condition

Symbol	Parameter	Conditions	Min.	Typ.	Max.	Unit
$V_{PN}$	Supply Voltage	Applied between P and N	-	300	400	V
$V_{DD}$	Control Supply Voltage	Applied between $V_{DD}$ and COM	13.5	15.0	16.5	V
$V_{BS}$	High-Side Bias Voltage	Applied between $V_B$ and $V_S$	13.5	15.0	16.5	V
$V_{IN(ON)}$	Input ON Threshold Voltage	Applied between $V_{IN}$ and COM	3.0	-	$V_{DD}$	V
$V_{IN(OFF)}$	Input OFF Threshold Voltage		0	-	0.6	V
$t_{dead}$	Blanking Time for Preventing Arm-Short	$V_{DD} = V_{BS} = 13.5 \sim 16.5 \text{ V}$ , $T_J \leq 150^\circ\text{C}$	1.0	-	-	$\mu\text{s}$
$f_{PWM}$	PWM Switching Frequency	$T_J \leq 150^\circ\text{C}$	-	15	-	kHz

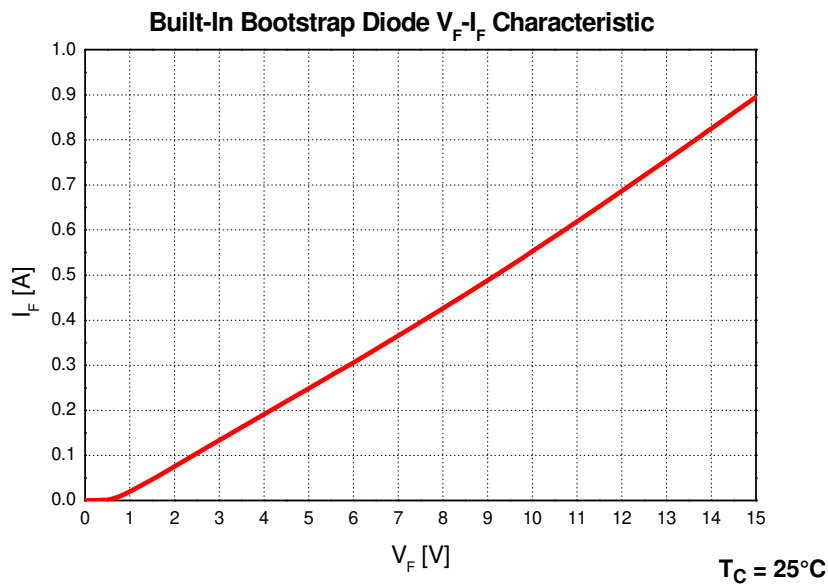

**Figure 3. Built-In Bootstrap Diode Characteristics (Typical)**

**Notes:**

4.  $BV_{DSS}$  is the absolute maximum voltage rating between drain and source terminal of each MOSFET inside Motion SPM® 5 product.  $V_{PN}$  should be sufficiently less than this value considering the effect of the stray inductance so that  $V_{PN}$  should not exceed  $BV_{DSS}$  in any case.
5.  $t_{ON}$  and  $t_{OFF}$  include the propagation delay of the internal drive IC. Listed values are measured at the laboratory test condition, and they can be different according to the field applications due to the effect of different printed circuit boards and wirings. Please see Figure 6 for the switching time definition with the switching test circuit of Figure 7.
6. The peak current and voltage of each MOSFET during the switching operation should be included in the Safe Operating Area (SOA). Please see Figure 7 for the RBSOA test circuit that is same as the switching test circuit.
7.  $V_{IS}$  is only for sensing-temperature of module and cannot shutdown MOSFETs automatically.
8. Built-in bootstrap diode includes around 15  $\Omega$  resistance characteristic. Please refer to Figure 2.

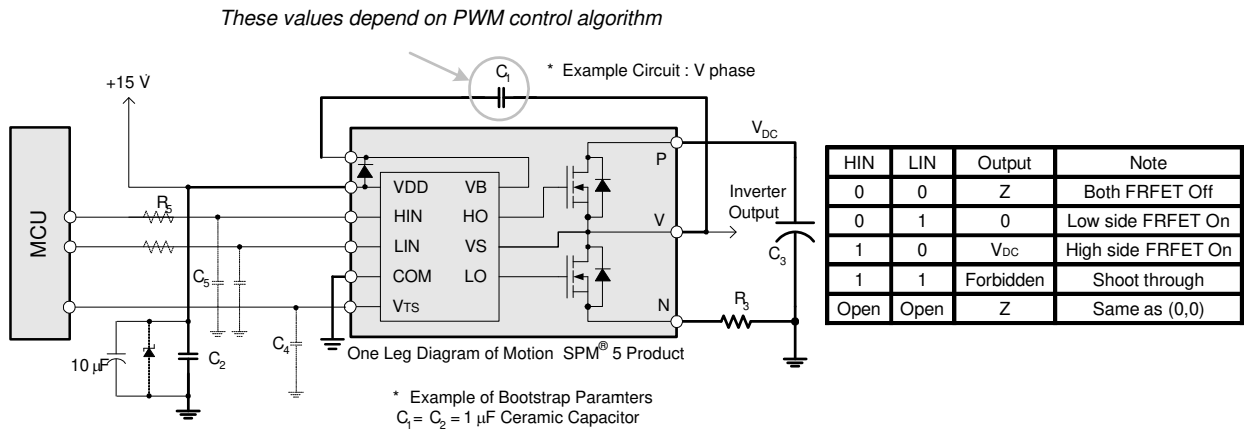

**Figure 4. Recommended MCU Interface and Bootstrap Circuit with Parameters**

**Notes:**

9. Parameters for bootstrap circuit elements are dependent on PWM algorithm. For 15 kHz of switching frequency, typical example of parameters is shown above.
10. RC-coupling (R<sub>5</sub> and C<sub>5</sub>) and C<sub>4</sub> at each input of Motion SPM 5 product and MCU (Indicated as Dotted Lines) may be used to prevent improper signal due to surge-noise.
11. Bold lines should be short and thick in PCB pattern to have small stray inductance of circuit, which results in the reduction of surge-voltage. Bypass capacitors such as C<sub>1</sub>, C<sub>2</sub> and C<sub>3</sub> should have good high-frequency characteristics to absorb high-frequency ripple-current.

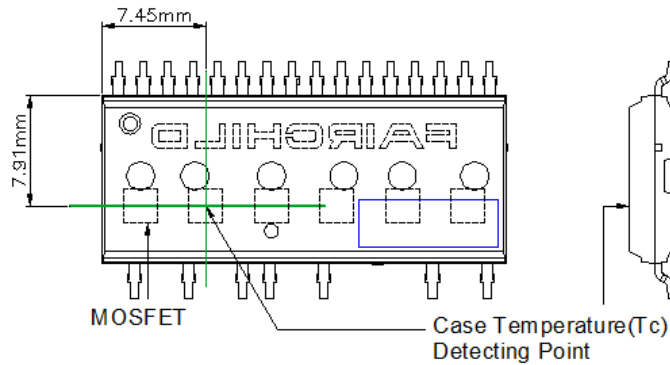

**Figure 5. Case Temperature Measurement**

**Notes:**

12. Attach the thermocouple on top of the heat-sink of SPM 5 package (between SPM 5 package and heatsink if applied) to get the correct temperature measurement.

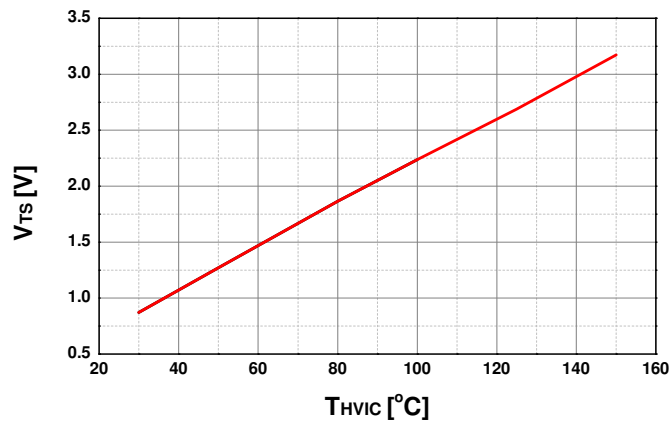

**Figure 6. Temperature Profile of V<sub>TS</sub> (Typical)**



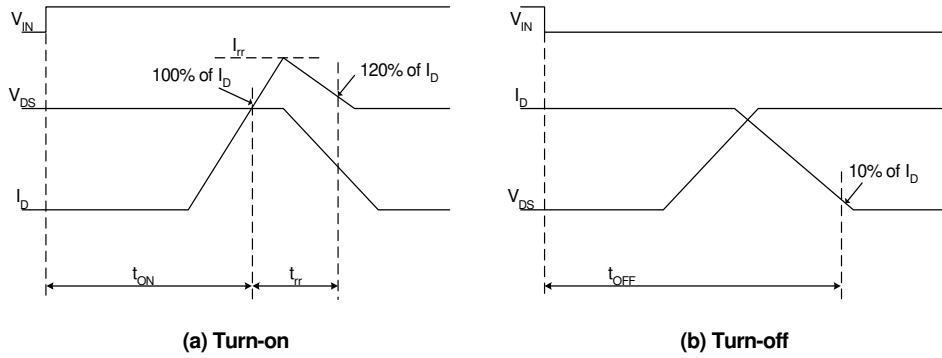
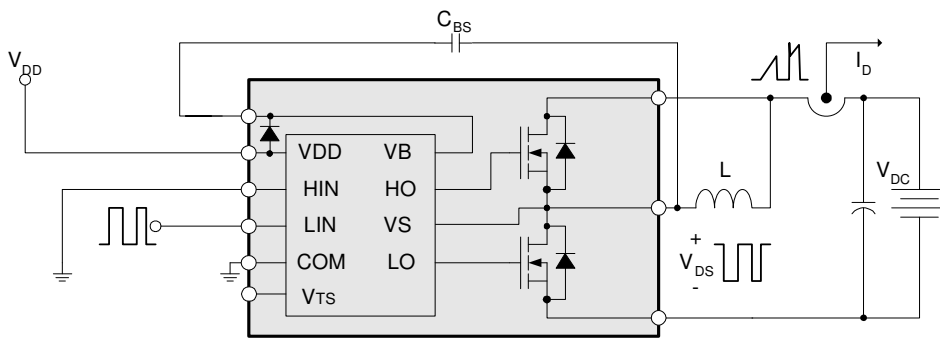

Figure 7. Switching Time Definitions



One Leg Diagram of Motion SPM® 5 Product

Figure 8. Switching and RBSOA (Single-Pulse) Test Circuit (Low-side)

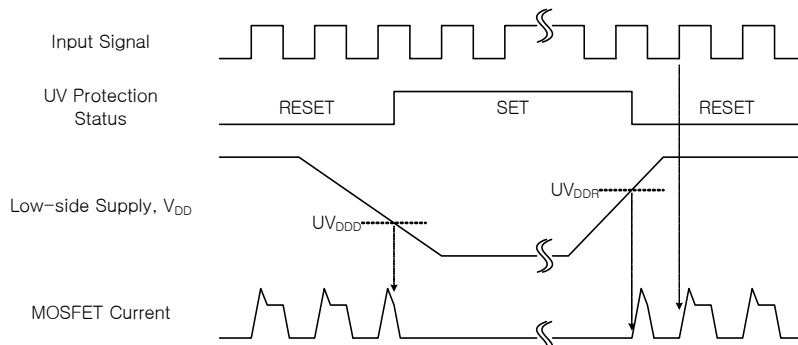

Figure 9. Under-Voltage Protection (Low-Side)

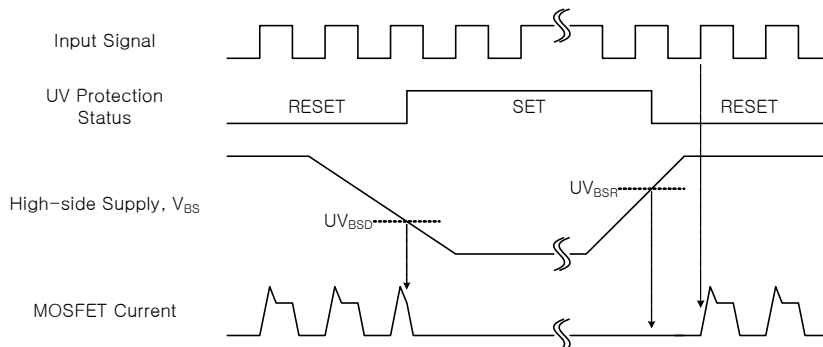

Figure 10. Under-Voltage Protection (High-Side)

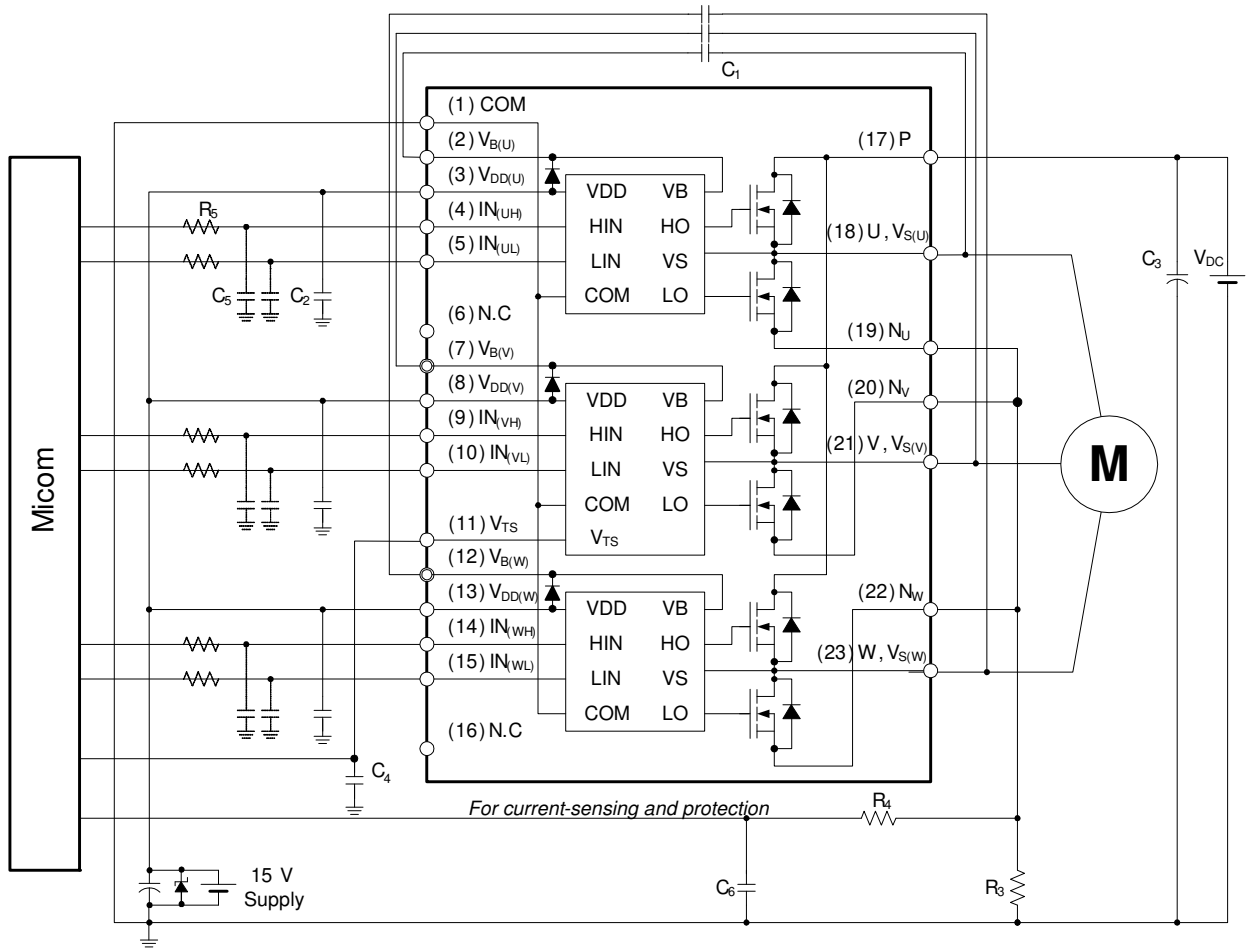
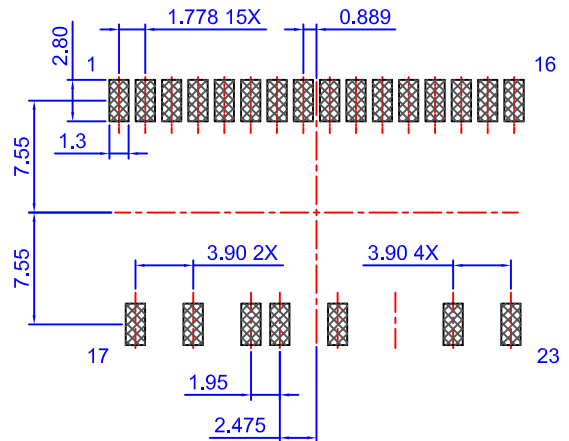
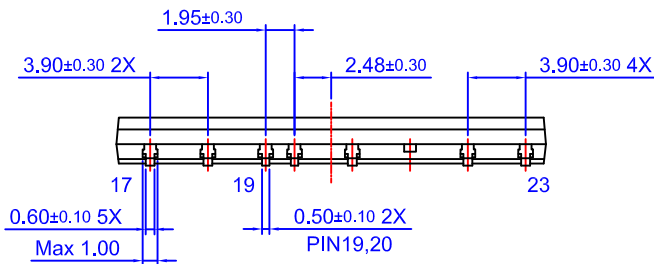
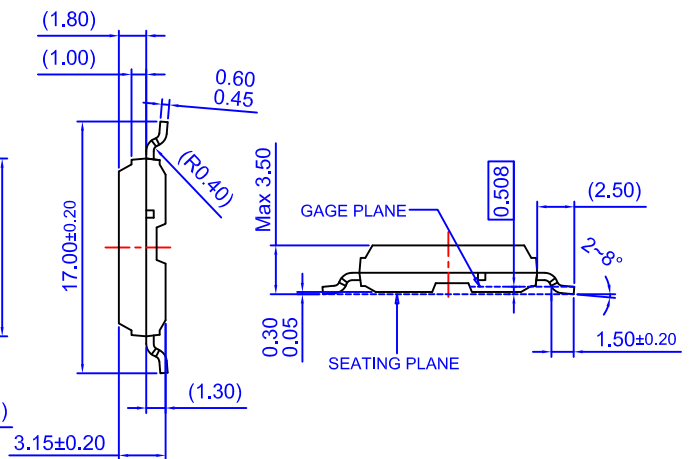
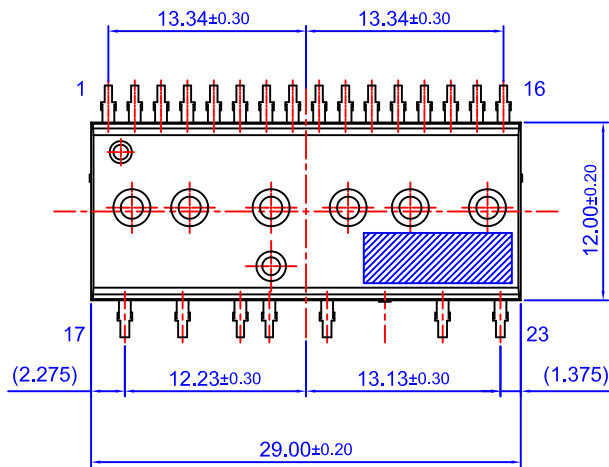
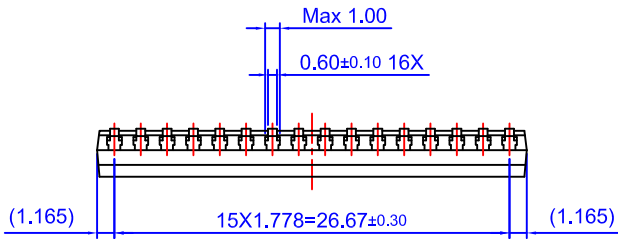

Figure 11. Example of Application Circuit

Notes:

- 13. About pin position, refer to Figure 1.
- 14. RC-coupling ( $R_5$  and  $C_5$ ,  $R_4$  and  $C_6$ ) and  $C_4$  at each input of Motion SPM® 5 product and MCU are useful to prevent improper input signal caused by surge-noise.
- 15. The voltage-drop across  $R_3$  affects the low-side switching performance and the bootstrap characteristics since it is placed between COM and the source terminal of the low-side MOSFET. For this reason, the voltage-drop across  $R_3$  should be less than 1 V in the steady-state.
- 16. Ground-wires and output terminals, should be thick and short in order to avoid surge-voltage and malfunction of HVIC.
- 17. All the filter capacitors should be connected close to Motion SPM 5 product, and they should have good characteristics for rejecting high-frequency ripple current.



- NOTES: UNLESS OTHERWISE SPECIFIED  
 A) THIS PACKAGE DOES NOT COMPLY TO ANY CURRENT PACKAGING STANDARD  
 B) ALL DIMENSIONS ARE IN MILLIMETERS  
 C) DIMENSIONS ARE EXCLUSIVE OF BURRS, MOLD FLASH, AND TIE BAR EXTRUSIONS  
 D) ( ) IS REFERENCE  
 E) DRAWING FILENAME: MOD23DGREV6.0  
 F) FAIRCHILD SEMICONDUCTOR



ON Semiconductor and  are trademarks of Semiconductor Components Industries, LLC dba ON Semiconductor or its subsidiaries in the United States and/or other countries. ON Semiconductor owns the rights to a number of patents, trademarks, copyrights, trade secrets, and other intellectual property. A listing of ON Semiconductor's product/patent coverage may be accessed at [www.onsemi.com/site/pdf/Patent-Marking.pdf](http://www.onsemi.com/site/pdf/Patent-Marking.pdf). ON Semiconductor reserves the right to make changes without further notice to any products herein. ON Semiconductor makes no warranty, representation or guarantee regarding the suitability of its products for any particular purpose, nor does ON Semiconductor assume any liability arising out of the application or use of any product or circuit, and specifically disclaims any and all liability, including without limitation special, consequential or incidental damages. Buyer is responsible for its products and applications using ON Semiconductor products, including compliance with all laws, regulations and safety requirements or standards, regardless of any support or applications information provided by ON Semiconductor. "Typical" parameters which may be provided in ON Semiconductor data sheets and/or specifications can and do vary in different applications and actual performance may vary over time. All operating parameters, including "Typicals" must be validated for each customer application by customer's technical experts. ON Semiconductor does not convey any license under its patent rights nor the rights of others. ON Semiconductor products are not designed, intended, or authorized for use as a critical component in life support systems or any FDA Class 3 medical devices or medical devices with a same or similar classification in a foreign jurisdiction or any devices intended for implantation in the human body. Should Buyer purchase or use ON Semiconductor products for any such unintended or unauthorized application, Buyer shall indemnify and hold ON Semiconductor and its officers, employees, subsidiaries, affiliates, and distributors harmless against all claims, costs, damages, and expenses, and reasonable attorney fees arising out of, directly or indirectly, any claim of personal injury or death associated with such unintended or unauthorized use, even if such claim alleges that ON Semiconductor was negligent regarding the design or manufacture of the part. ON Semiconductor is an Equal Opportunity/Affirmative Action Employer. This literature is subject to all applicable copyright laws and is not for resale in any manner.

## PUBLICATION ORDERING INFORMATION

### LITERATURE FULFILLMENT:

Literature Distribution Center for ON Semiconductor  
19521 E. 32nd Pkwy, Aurora, Colorado 80011 USA  
**Phone:** 303-675-2175 or 800-344-3860 Toll Free USA/Canada  
**Fax:** 303-675-2176 or 800-344-3867 Toll Free USA/Canada  
**Email:** [orderlit@onsemi.com](mailto:orderlit@onsemi.com)

**N. American Technical Support:** 800-282-9855 Toll Free  
USA/Canada  
**Europe, Middle East and Africa Technical Support:**  
Phone: 421 33 790 2910  
**Japan Customer Focus Center**  
Phone: 81-3-5817-1050

**ON Semiconductor Website:** [www.onsemi.com](http://www.onsemi.com)  
**Order Literature:** <http://www.onsemi.com/orderlit>  
For additional information, please contact your local  
Sales Representative