



Chipsmall Limited consists of a professional team with an average of over 10 year of expertise in the distribution of electronic components. Based in Hongkong, we have already established firm and mutual-benefit business relationships with customers from,Europe,America and south Asia,supplying obsolete and hard-to-find components to meet their specific needs.

With the principle of “Quality Parts,Customers Priority,Honest Operation,and Considerate Service”,our business mainly focus on the distribution of electronic components. Line cards we deal with include Microchip,ALPS,ROHM,Xilinx,Pulse,ON,Everlight and Freescale. Main products comprise IC,Modules,Potentiometer,IC Socket,Relay,Connector.Our parts cover such applications as commercial,industrial, and automotives areas.

We are looking forward to setting up business relationship with you and hope to provide you with the best service and solution. Let us make a better world for our industry!



Contact us

Tel: +86-755-8981 8866 Fax: +86-755-8427 6832

Email & Skype: info@chipsmall.com Web: www.chipsmall.com

Address: A1208, Overseas Decoration Building, #122 Zhenhua RD., Futian, Shenzhen, China





Is Now Part of



ON Semiconductor®

To learn more about ON Semiconductor, please visit our website at
www.onsemi.com

ON Semiconductor and the ON Semiconductor logo are trademarks of Semiconductor Components Industries, LLC dba ON Semiconductor or its subsidiaries in the United States and/or other countries. ON Semiconductor owns the rights to a number of patents, trademarks, copyrights, trade secrets, and other intellectual property. A listing of ON Semiconductor's product/patent coverage may be accessed at www.onsemi.com/site/pdf/Patent-Marking.pdf. ON Semiconductor reserves the right to make changes without further notice to any products herein. ON Semiconductor makes no warranty, representation or guarantee regarding the suitability of its products for any particular purpose, nor does ON Semiconductor assume any liability arising out of the application or use of any product or circuit, and specifically disclaims any and all liability, including without limitation special, consequential or incidental damages. Buyer is responsible for its products and applications using ON Semiconductor products, including compliance with all laws, regulations and safety requirements or standards, regardless of any support or applications information provided by ON Semiconductor. "Typical" parameters which may be provided in ON Semiconductor data sheets and/or specifications can and do vary in different applications and actual performance may vary over time. All operating parameters, including "Typicals" must be validated for each customer application by customer's technical experts. ON Semiconductor does not convey any license under its patent rights nor the rights of others. ON Semiconductor products are not designed, intended, or authorized for use as a critical component in life support systems or any FDA Class 3 medical devices or medical devices with a same or similar classification in a foreign jurisdiction or any devices intended for implantation in the human body. Should Buyer purchase or use ON Semiconductor products for any such unintended or unauthorized application, Buyer shall indemnify and hold ON Semiconductor and its officers, employees, subsidiaries, affiliates, and distributors harmless against all claims, costs, damages, and expenses, and reasonable attorney fees arising out of, directly or indirectly, any claim of personal injury or death associated with such unintended or unauthorized use, even if such claim alleges that ON Semiconductor was negligent regarding the design or manufacture of the part. ON Semiconductor is an Equal Opportunity/Affirmative Action Employer. This literature is subject to all applicable copyright laws and is not for resale in any manner.



FSB50450T

Smart Power Module (SPM®)

Features

- 500V 3.0A 3-phase FRFET inverter including high voltage integrated circuit (HVIC)
- 3 divided negative dc-link terminals for inverter current sensing applications
- HVIC for gate driving and undervoltage protection
- 3/5V CMOS/TTL compatible, active-high interface
- Optimized for low electromagnetic interference
- Isolation voltage rating of 1500Vrms for 1min.
- Extended VB pin for PCB isolation

General Description

FSB50450T is a tiny smart power module (SPM®) based on FRFET technology as a compact inverter solution for small power motor drive applications such as fan motors and water suppliers. It is composed of 6 fast-recovery MOSFET (FRFET), and 3 half-bridge HVICs for FRFET gate driving. FSB50450T provides low electromagnetic interference (EMI) characteristics with optimized switching speed. Moreover, since it employs FRFET as a power switch, it has much better ruggedness and larger safe operation area (SOA) than that of an IGBT-based power module or one-chip solution. The package is optimized for the thermal performance and compactness for the use in the built-in motor application and any other application where the assembly space is concerned. FSB50450T is the most solution for the compact inverter providing the energy efficiency, compactness, and low electromagnetic interference.



Absolute Maximum Ratings

| Symbol | Parameter | Conditions | Rating | Units |
|-----------------|--|--|---------------------|---------------------------|
| V_{PN} | DC Link Input Voltage, Drain-source Voltage of each FRFET | | 500 | V |
| I_{D25} | Each FRFET Drain Current, Continuous | $T_C = 25^\circ\text{C}$ | 1.5 | A |
| I_{D80} | Each FRFET Drain Current, Continuous | $T_C = 100^\circ\text{C}$ | 1.0 | A |
| I_{DP} | Each FRFET Drain Current, Peak | $T_C = 25^\circ\text{C}$, $PW < 100\mu\text{s}$ | 3.0 | A |
| P_D | Maximum Power Dissipation | $T_C = 25^\circ\text{C}$, Each FRFET | 10 | W |
| V_{CC} | Control Supply Voltage | Applied between V_{CC} and COM | 20 | V |
| V_{BS} | High-side Bias Voltage | Applied between $V_{B(U)}-U$, $V_{B(V)}-V$, $V_{B(W)}-W$ | 20 | V |
| V_{IN} | Input Signal Voltage | Applied between IN and COM | -0.3 ~ $V_{CC}+0.3$ | V |
| T_J | Operating Junction Temperature | | -20 ~ 150 | $^\circ\text{C}$ |
| T_{STG} | Storage Temperature | | -50 ~ 150 | $^\circ\text{C}$ |
| $R_{\theta JC}$ | Junction to Case Thermal Resistance | Each FRFET under inverter operating condition (Note 1) | 8.9 | $^\circ\text{C}/\text{W}$ |
| V_{ISO} | Isolation Voltage | 60Hz, Sinusoidal, 1 minute, Connection pins to heatsink | 1500 | V_{rms} |

Pin Descriptions

| Pin Number | Pin Name | Pin Description |
|------------|---------------|--|
| 1 | COM | IC Common Supply Ground |
| 2 | $V_{B(U)}$ | Bias Voltage for U Phase High Side FRFET Driving |
| 3 | $V_{CC(U)}$ | Bias Voltage for U Phase IC and Low Side FRFET Driving |
| 4 | $IN_{(UH)}$ | Signal Input for U Phase High-side |
| 5 | $IN_{(UL)}$ | Signal Input for U Phase Low-side |
| 6 | NC | No Connection |
| 7 | $V_{B(V)}$ | Bias Voltage for V Phase High Side FRFET Driving |
| 8 | $V_{CC(V)}$ | Bias Voltage for V Phase IC and Low Side FRFET Driving |
| 9 | $IN_{(VH)}$ | Signal Input for V Phase High-side |
| 10 | $IN_{(VL)}$ | Signal Input for V Phase Low-side |
| 11 | NC | No Connection |
| 12 | $V_{B(W)}$ | Bias Voltage for W Phase High Side FRFET Driving |
| 13 | $V_{CC(W)}$ | Bias Voltage for W Phase IC and Low Side FRFET Driving |
| 14 | $IN_{(WH)}$ | Signal Input for W Phase High-side |
| 15 | $IN_{(WL)}$ | Signal Input for W Phase Low-side |
| 16 | NC | No Connection |
| 17 | P | Positive DC-Link Input |
| 18 | U, $V_{S(U)}$ | Output for U Phase & Bias Voltage Ground for High Side FRFET Driving |
| 19 | N_U | Negative DC-Link Input for U Phase |
| 20 | N_V | Negative DC-Link Input for V Phase |
| 21 | V, $V_{S(V)}$ | Output for V Phase & Bias Voltage Ground for High Side FRFET Driving |
| 22 | N_W | Negative DC-Link Input for W Phase |
| 23 | W, $V_{S(W)}$ | Output for W Phase & Bias Voltage Ground for High Side FRFET Driving |

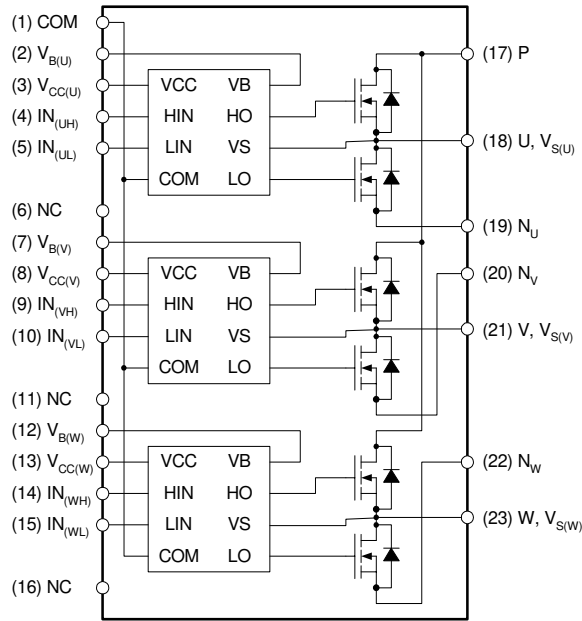

Note:

Source terminal of each low-side MOSFET is not connected to supply ground or bias voltage ground inside SPM®. External connections should be made as indicated in Figure 2 and 5.

Figure 1. Pin Configuration and Internal Block Diagram (Bottom View)

Electrical Characteristics (T_J = 25°C, V_{CC}=V_{BS}=15V Unless Otherwise Specified)

Inverter Part (Each FRFET Unless Otherwise Specified)

| Symbol | Parameter | Conditions | Min | Typ | Max | Units |
|-------------------------------------|---|--|-------------|------|-----|-------|
| BV _{DSS} | Drain-Source Breakdown Voltage | V _{IN} = 0V, I _D = 250μA (Note 2) | 500 | - | - | V |
| ΔBV _{DSS} /ΔT _J | Breakdown Voltage Temperature Coefficient | I _D = 250μA, Referenced to 25°C | - | 0.53 | - | V |
| I _{DSS} | Zero Gate Voltage Drain Current | V _{IN} = 0V, V _{DS} = 500V | - | - | 250 | μA |
| R _{DS(on)} | Static Drain-Source On-Resistance | V _{CC} = V _{BS} = 15V, V _{IN} = 5V, I _D = 1.0A | - | 1.9 | 2.4 | Ω |
| V _{SD} | Drain-Source Diode Forward Voltage | V _{CC} = V _{BS} = 15V, V _{IN} = 0V, I _D = -1.0A | - | - | 1.2 | V |
| t _{ON} | Switching Times | V _{PN} = 300V, V _{CC} = V _{BS} = 15V, I _D = 1.0A V _{IN} = 0V ↔ 5V Inductive load L=3mH High- and low-side FRFET switching (Note 3) | - | 1152 | - | ns |
| t _{OFF} | | | - | 600 | - | ns |
| t _{rr} | | | - | 185 | - | ns |
| E _{ON} | | | - | 85 | - | μJ |
| E _{OFF} | | | - | 11 | - | μJ |
| RBSOA | Reverse-bias Safe Operating Area | V _{PN} = 400V, V _{CC} = V _{BS} = 15V, I _D = I _{DP} , R _{EH} = 0Ω V _{DS} =BV _{DSS} , T _J = 150°C High- and low-side FRFET switching (Note 4) | Full Square | | | |

Control Part (Each HVIC Unless Otherwise Specified)

| Symbol | Parameter | Conditions | Min | Typ | Max | Units |
|-------------------|--|--|-----|-----|-----|-------|
| I _{QCC} | Quiescent V _{CC} Current | V _{CC} =15V, V _{IN} =0V Applied between V _{CC} and COM | - | - | 160 | μA |
| I _{QBS} | Quiescent V _{BS} Current | V _{BS} =15V, V _{IN} =0V Applied between V _{B(U)} -U, V _{B(V)} -V, V _{B(W)} -W | - | - | 100 | μA |
| UV _{CCD} | Low-side Undervoltage Protection (Figure 6) | V _{CC} Undervoltage Protection Detection Level | 7.4 | 8.0 | 9.4 | V |
| UV _{CCR} | | V _{CC} Undervoltage Protection Reset Level | 8.0 | 8.9 | 9.8 | V |
| UV _{BSD} | High-side Undervoltage Protection (Figure 7) | V _{BS} Undervoltage Protection Detection Level | 7.4 | 8.0 | 9.4 | V |
| UV _{BSR} | | V _{BS} Undervoltage Protection Reset Level | 8.0 | 8.9 | 9.8 | V |
| V _{IH} | ON Threshold Voltage | Logic High Level | 3.0 | - | - | V |
| V _{IL} | OFF Threshold Voltage | Logic Low Level | | | | |
| I _{IH} | Input Bias Current | V _{IN} = 5V | - | 10 | 20 | μA |
| I _{IL} | | V _{IN} = 0V | - | - | 2 | μA |

Note:

- For the measurement point of case temperature T_C, please refer to Figure 3 in page 4.
- BV_{DSS} is the absolute maximum voltage rating between drain and source terminal of each FRFET inside SPM®. V_{PN} should be sufficiently less than this value considering the effect of the stray inductance so that V_{DS} should not exceed BV_{DSS} in any case.
- t_{ON} and t_{OFF} include the propagation delay time of the internal drive IC. Listed values are measured at the laboratory test condition, and they can be different according to the field applications due to the effect of different printed circuit boards and wirings. Please see Figure 4 for the switching time definition with the switching test circuit of Figure 5.
- The peak current and voltage of each FRFET during the switching operation should be included in the safe operating area (SOA). Please see Figure 5 for the RBSOA test circuit that is same as the switching test circuit.

Package Marking & Ordering Information

| Device Marking | Device | Package | Reel Size | Tape Width | Quantity |
|----------------|-----------|---------|-----------|------------|----------|
| FSB50450T | FSB50450T | SPM23AC | - | - | 15 |

Recommended Operating Conditions

| Symbol | Parameter | Conditions | Value | | | Units |
|---------------|--|---|-------|------|----------|------------|
| | | | Min. | Typ. | Max. | |
| V_{PN} | Supply Voltage | Applied between P and N | - | 300 | 400 | V |
| V_{CC} | Control Supply Voltage | Applied between V_{CC} and COM | 12 | 15 | 16.5 | V |
| V_{BS} | High-side Bias Voltage | Applied between V_B and output(U, V, W) | 12 | 15 | 16.5 | V |
| $V_{IN(ON)}$ | Input ON Threshold Voltage | Applied between IN and COM | 3.0 | - | V_{CC} | V |
| $V_{IN(OFF)}$ | Input OFF Threshold Voltage | | 0 | - | 0.6 | V |
| t_{dead} | Blanking Time for Preventing Arm-short | $V_{CC}=V_{BS}=12 \sim 16.5V, T_J \leq 150^\circ C$ | 1.0 | - | - | μs |
| f_{PWM} | PWM Switching Frequency | $T_J \leq 150^\circ C$ | - | 15 | - | kHz |
| T_C | Case Temperature | $T_J \leq 150^\circ C$ | -20 | - | 125 | $^\circ C$ |

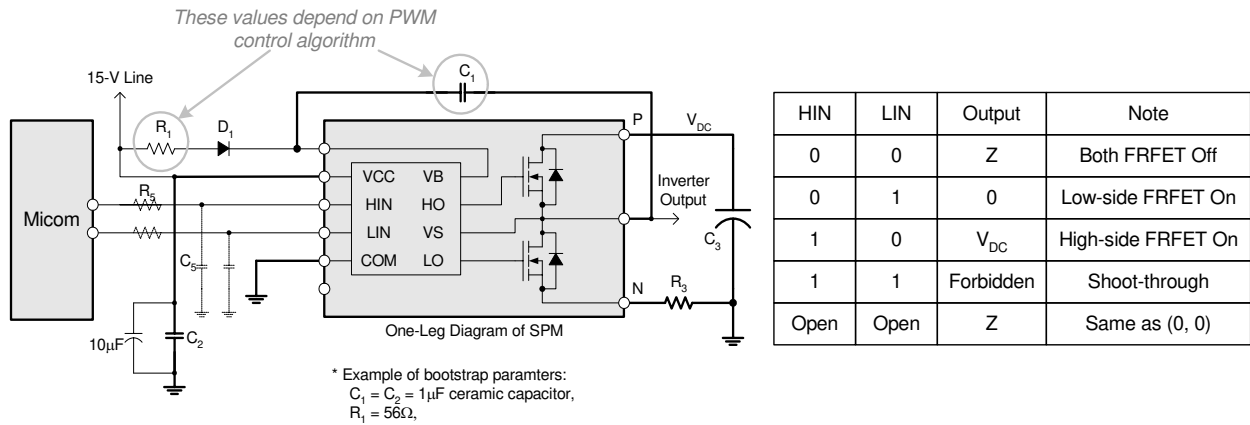

Note:

- (1) It is recommended the bootstrap diode D_1 to have soft and fast recovery characteristics with 600-V rating
- (2) Parameters for bootstrap circuit elements are dependent on PWM algorithm. For 15 kHz of switching frequency, typical example of parameters is shown above.
- (3) RC coupling (R_5 and C_5) at each input (indicated as dotted lines) may be used to prevent improper input signal due to surge noise. Signal input of SPM® is compatible with standard CMOS or LSTTL outputs.
- (4) Bold lines should be short and thick in PCB pattern to have small stray inductance of circuit, which results in the reduction of surge voltage. Bypass capacitors such as C_1 , C_2 and C_3 should have good high-frequency characteristics to absorb high-frequency ripple current.

Figure 2. Recommended CPU Interface and Bootstrap Circuit with Parameters

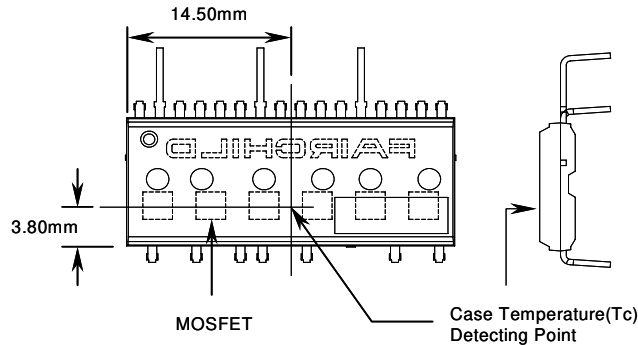

Note:

Attach the thermocouple on top of the heatsink-side of SPM® (between SPM® and heatsink if applied) to get the correct temperature measurement.

Figure 3. Case Temperature Measurement

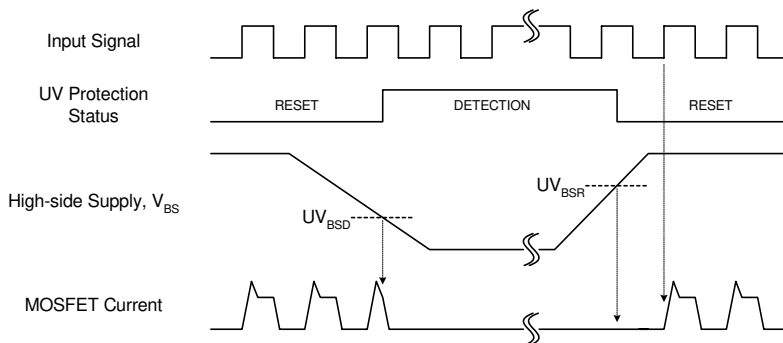
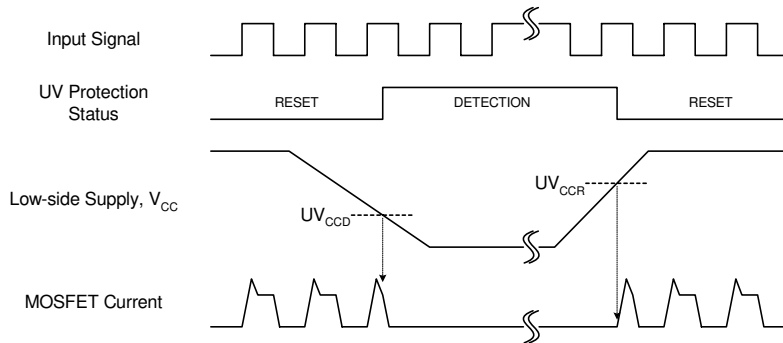
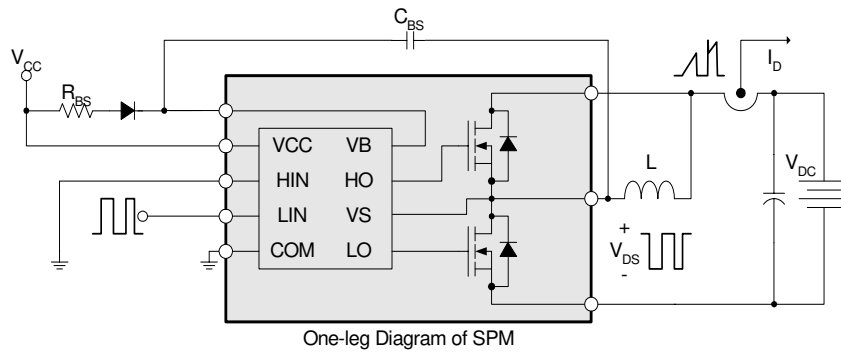
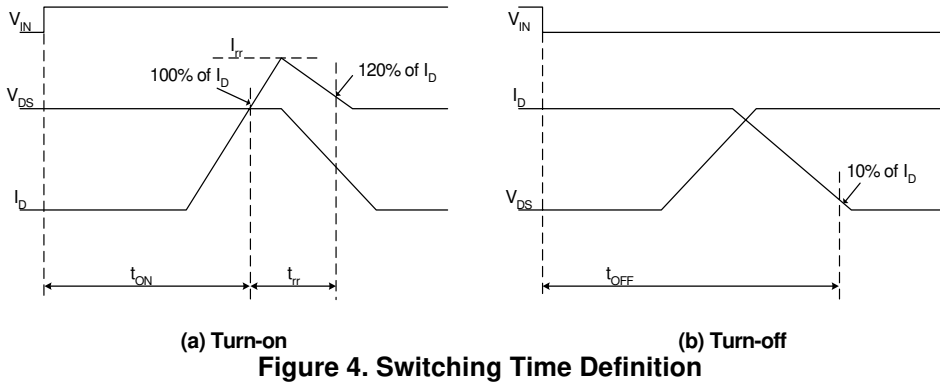

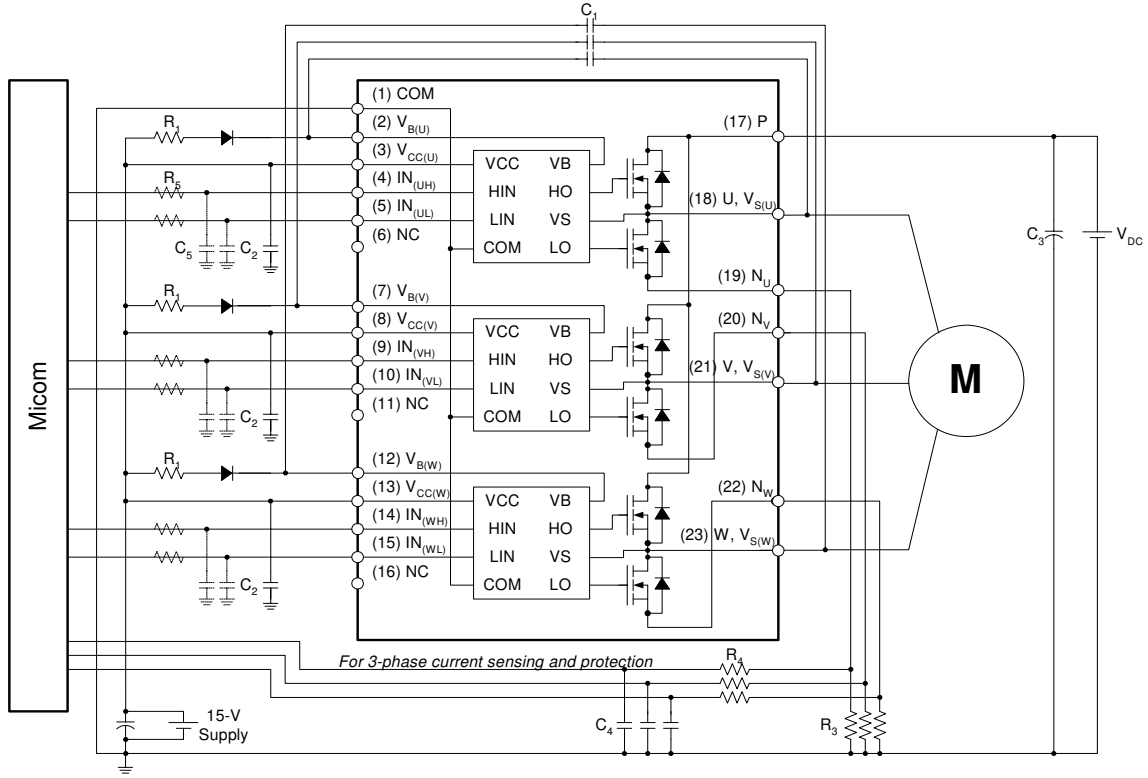
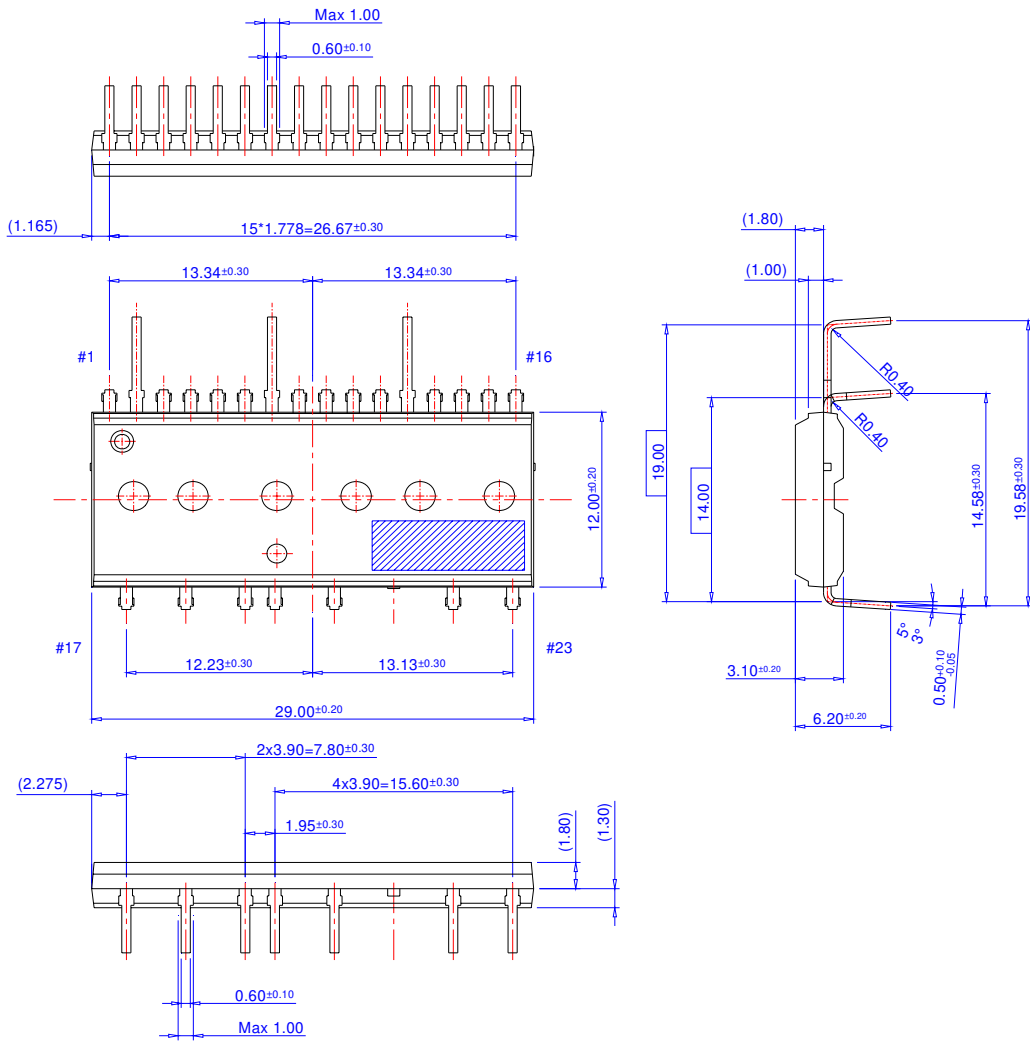

Figure 8. Example of Application Circuit

Detailed Package Outline Drawings





TRADEMARKS

The following are registered and unregistered trademarks Fairchild Semiconductor owns or is authorized to use and is not intended to be an exhaustive list of all such trademarks.

| | | | |
|--------------------------------------|--------------------|----------------------------|-----------------|
| ACEx® | HiSeC™ | Power-SPM™ | TinyBuck™ |
| Across the board. Around the world.™ | <i>i-Lo</i> ™ | PowerTrench® | TinyLogic® |
| ActiveArray™ | ImpliedDisconnect™ | Programmable Active Droop™ | TINYOPTO™ |
| Bottomless™ | IntelliMAX™ | QFET® | TinyPower™ |
| Build it Now™ | ISOPLANAR™ | QS™ | TinyWire™ |
| CoolFET™ | MICROCOUPLER™ | QT Optoelectronics™ | TruTranslation™ |
| CorePLUS™ | MicroPak™ | Quiet Series™ | µSerDes™ |
| CROSSVOLT™ | MICROWIRE™ | RapidConfigure™ | UHC® |
| CTL™ | Motion-SPM™ | RapidConnect™ | UniFET™ |
| Current Transfer Logic™ | MSX™ | ScalarPump™ | VCX™ |
| DOME™ | MSXPro™ | SMART START™ | Wire™ |
| E ² C MOS™ | OCX™ | SPM® | |
| EcoSPARK® | OCXPro™ | STEALTH™ | |
| EnSigna™ | OPTOLOGIC® | SuperFET™ | |
| FACT Quiet Series™ | OPTOPLANAR® | SuperSOT™-3 | |
| FACT® | PACMAN™ | SuperSOT™-6 | |
| FAST® | PDP-SPM™ | SuperSOT™-8 | |
| FASTr™ | POP™ | SyncFET™ | |
| FPS™ | Power220® | TCM™ | |
| FRFET® | Power247® | The Power Franchise® | |
| GlobalOptoisolator™ | PowerEdge™ | ™ | |
| GTO™ | PowerSaver™ | TinyBoost™ | |

DISCLAIMER

FAIRCHILD SEMICONDUCTOR RESERVES THE RIGHT TO MAKE CHANGES WITHOUT FURTHER NOTICE TO ANY PRODUCTS HEREIN TO IMPROVE RELIABILITY, FUNCTION, OR DESIGN. FAIRCHILD DOES NOT ASSUME ANY LIABILITY ARISING OUT OF THE APPLICATION OR USE OF ANY PRODUCT OR CIRCUIT DESCRIBED HEREIN; NEITHER DOES IT CONVEY ANY LICENSE UNDER ITS PATENT RIGHTS, NOR THE RIGHTS OF OTHERS. THESE SPECIFICATIONS DO NOT EXPAND THE TERMS OF FAIRCHILD'S WORLDWIDE TERMS AND CONDITIONS, SPECIFICALLY THE WARRANTY THEREIN, WHICH COVERS THESE PRODUCTS.

LIFE SUPPORT POLICY

FAIRCHILD'S PRODUCTS ARE NOT AUTHORIZED FOR USE AS CRITICAL COMPONENTS IN LIFE SUPPORT DEVICES OR SYSTEMS WITHOUT THE EXPRESS WRITTEN APPROVAL OF FAIRCHILD SEMICONDUCTOR CORPORATION.

As used herein:

1. Life support devices or systems are devices or systems which, (a) are intended for surgical implant into the body or (b) support or sustain life, and (c) whose failure to perform when properly used in accordance with instructions for use provided in the labeling, can be reasonably expected to result in a significant injury of the user.
2. A critical component in any component of a life support, device, or system whose failure to perform can be reasonably expected to cause the failure of the life support device or system, or to affect its safety or effectiveness.

PRODUCT STATUS DEFINITIONS

Definition of Terms

| Datasheet Identification | Product Status | Definition |
|--------------------------|------------------------|--|
| Advance Information | Formative or In Design | This datasheet contains the design specifications for product development. Specifications may change in any manner without notice. |
| Preliminary | First Production | This datasheet contains preliminary data; supplementary data will be published at a later date. Fairchild Semiconductor reserves the right to make changes at any time without notice to improve design. |
| No Identification Needed | Full Production | This datasheet contains final specifications. Fairchild Semiconductor reserves the right to make changes at any time without notice to improve design. |
| Obsolete | Not In Production | This datasheet contains specifications on a product that has been discontinued by Fairchild Semiconductor. The datasheet is printed for reference information only. |

Rev. I27

ON Semiconductor and  are trademarks of Semiconductor Components Industries, LLC dba ON Semiconductor or its subsidiaries in the United States and/or other countries. ON Semiconductor owns the rights to a number of patents, trademarks, copyrights, trade secrets, and other intellectual property. A listing of ON Semiconductor's product/patent coverage may be accessed at www.onsemi.com/site/pdf/Patent-Marking.pdf. ON Semiconductor reserves the right to make changes without further notice to any products herein. ON Semiconductor makes no warranty, representation or guarantee regarding the suitability of its products for any particular purpose, nor does ON Semiconductor assume any liability arising out of the application or use of any product or circuit, and specifically disclaims any and all liability, including without limitation special, consequential or incidental damages. Buyer is responsible for its products and applications using ON Semiconductor products, including compliance with all laws, regulations and safety requirements or standards, regardless of any support or applications information provided by ON Semiconductor. "Typical" parameters which may be provided in ON Semiconductor data sheets and/or specifications can and do vary in different applications and actual performance may vary over time. All operating parameters, including "Typicals" must be validated for each customer application by customer's technical experts. ON Semiconductor does not convey any license under its patent rights nor the rights of others. ON Semiconductor products are not designed, intended, or authorized for use as a critical component in life support systems or any FDA Class 3 medical devices or medical devices with a same or similar classification in a foreign jurisdiction or any devices intended for implantation in the human body. Should Buyer purchase or use ON Semiconductor products for any such unintended or unauthorized application, Buyer shall indemnify and hold ON Semiconductor and its officers, employees, subsidiaries, affiliates, and distributors harmless against all claims, costs, damages, and expenses, and reasonable attorney fees arising out of, directly or indirectly, any claim of personal injury or death associated with such unintended or unauthorized use, even if such claim alleges that ON Semiconductor was negligent regarding the design or manufacture of the part. ON Semiconductor is an Equal Opportunity/Affirmative Action Employer. This literature is subject to all applicable copyright laws and is not for resale in any manner.

PUBLICATION ORDERING INFORMATION

LITERATURE FULFILLMENT:

Literature Distribution Center for ON Semiconductor
19521 E. 32nd Pkwy, Aurora, Colorado 80011 USA
Phone: 303-675-2175 or 800-344-3860 Toll Free USA/Canada
Fax: 303-675-2176 or 800-344-3867 Toll Free USA/Canada
Email: orderlit@onsemi.com

N. American Technical Support: 800-282-9855 Toll Free
USA/Canada
Europe, Middle East and Africa Technical Support:
Phone: 421 33 790 2910
Japan Customer Focus Center
Phone: 81-3-5817-1050

ON Semiconductor Website: www.onsemi.com
Order Literature: <http://www.onsemi.com/orderlit>
For additional information, please contact your local
Sales Representative