



Chipsmall Limited consists of a professional team with an average of over 10 year of expertise in the distribution of electronic components. Based in Hongkong, we have already established firm and mutual-benefit business relationships with customers from,Europe,America and south Asia,supplying obsolete and hard-to-find components to meet their specific needs.

With the principle of “Quality Parts,Customers Priority,Honest Operation,and Considerate Service”,our business mainly focus on the distribution of electronic components. Line cards we deal with include Microchip,ALPS,ROHM,Xilinx,Pulse,ON,Everlight and Freescale. Main products comprise IC,Modules,Potentiometer,IC Socket,Relay,Connector.Our parts cover such applications as commercial,industrial, and automotives areas.

We are looking forward to setting up business relationship with you and hope to provide you with the best service and solution. Let us make a better world for our industry!



Contact us

Tel: +86-755-8981 8866 Fax: +86-755-8427 6832

Email & Skype: info@chipsmall.com Web: www.chipsmall.com

Address: A1208, Overseas Decoration Building, #122 Zhenhua RD., Futian, Shenzhen, China





Is Now Part of



ON Semiconductor®

To learn more about ON Semiconductor, please visit our website at
www.onsemi.com

Please note: As part of the Fairchild Semiconductor integration, some of the Fairchild orderable part numbers will need to change in order to meet ON Semiconductor's system requirements. Since the ON Semiconductor product management systems do not have the ability to manage part nomenclature that utilizes an underscore (_), the underscore (_) in the Fairchild part numbers will be changed to a dash (-). This document may contain device numbers with an underscore (_). Please check the ON Semiconductor website to verify the updated device numbers. The most current and up-to-date ordering information can be found at www.onsemi.com. Please email any questions regarding the system integration to Fairchild_questions@onsemi.com.

ON Semiconductor and the ON Semiconductor logo are trademarks of Semiconductor Components Industries, LLC dba ON Semiconductor or its subsidiaries in the United States and/or other countries. ON Semiconductor owns the rights to a number of patents, trademarks, copyrights, trade secrets, and other intellectual property. A listing of ON Semiconductor's product/patent coverage may be accessed at www.onsemi.com/site/pdf/Patent-Marking.pdf. ON Semiconductor reserves the right to make changes without further notice to any products herein. ON Semiconductor makes no warranty, representation or guarantee regarding the suitability of its products for any particular purpose, nor does ON Semiconductor assume any liability arising out of the application or use of any product or circuit, and specifically disclaims any and all liability, including without limitation special, consequential or incidental damages. Buyer is responsible for its products and applications using ON Semiconductor products, including compliance with all laws, regulations and safety requirements or standards, regardless of any support or applications information provided by ON Semiconductor. "Typical" parameters which may be provided in ON Semiconductor data sheets and/or specifications can and do vary in different applications and actual performance may vary over time. All operating parameters, including "Typicals" must be validated for each customer application by customer's technical experts. ON Semiconductor does not convey any license under its patent rights nor the rights of others. ON Semiconductor products are not designed, intended, or authorized for use as a critical component in life support systems or any FDA Class 3 medical devices or medical devices with a same or similar classification in a foreign jurisdiction or any devices intended for implantation in the human body. Should Buyer purchase or use ON Semiconductor products for any such unintended or unauthorized application, Buyer shall indemnify and hold ON Semiconductor and its officers, employees, subsidiaries, affiliates, and distributors harmless against all claims, costs, damages, and expenses, and reasonable attorney fees arising out of, directly or indirectly, any claim of personal injury or death associated with such unintended or unauthorized use, even if such claim alleges that ON Semiconductor was negligent regarding the design or manufacture of the part. ON Semiconductor is an Equal Opportunity/Affirmative Action Employer. This literature is subject to all applicable copyright laws and is not for resale in any manner.

FSDM311A

Green Mode Fairchild Power Switch (FPS™)

Features

- Internal Avalanche-Rugged SenseFET
- Precision Fixed Operating Frequency: 67KHz
- Consumes Under 0.2W at 265V_{AC} & No Load with Advanced Burst-Mode Operation
- Internal Start-up Circuit
- Pulse-by-Pulse Current Limiting
- Over-Voltage Protection (OVP)
- Overload Protection (OLP)
- Internal Thermal Shutdown Function (TSD)
- Auto-Restart Mode
- Under-Voltage Lockout (UVLO) with Hysteresis
- Built-in Soft-Start
- Secondary-Side Regulation

Applications

- Charger & Adapter for Mobile Phone, PDA, & MP3
- Auxiliary Power for White Goods, PC, C-TV, & Monitors

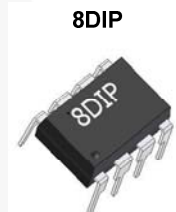

Description

The FSDM311A consists of an integrated Pulse Width Modulator (PWM) and SenseFET, and is specifically designed for high-performance, off-line, Switch-Mode Power Supplies (SMPS) with minimal external components. This device is an integrated high-voltage power switching regulator that combines a VDMOS SenseFET with a voltage-mode PWM control block. The integrated PWM controller features include a fixed oscillator, Under-Voltage Lockout (UVLO) protection, Leading-Edge Blanking (LEB), an optimized gate turn-on/turn-off driver, Thermal Shutdown (TSD) protection, and temperature-compensated precision-current sources for loop compensation and fault protection circuitry. When compared to a discrete MOSFET and controller or RCC switching converter solution, the FSDM311A device reduces total component count and design size and weight, while increasing efficiency, productivity, and system reliability. This device provides a basic platform that is well suited for the design of cost-effective flyback converters.

Related Resources

- [AN-4134: Design Guidelines for Off-line Forward Converters Using Fairchild Power Switch \(FPS™\)](#)
- [AN-4137: Design Guidelines for Off-line Flyback Converters Using Fairchild Power Switch \(FPS™\)](#)
- [AN-4138: Design Considerations for Battery Charger Using Green Mode Fairchild Power Switch \(FPS™\)](#)
- [AN-4140: Transformer Design Consideration for Off-line Flyback Converters Using Fairchild Power Switch \(FPS™\)](#)
- [AN-4141: Troubleshooting and Design Tips for Fairchild Power Switch \(FPS™\) Flyback Applications](#)
- [AN-4147: Design Guidelines for RCD Snubber of Flyback](#)
- [AN-4148: Audible Noise Reduction Techniques for FPS™ Applications](#)

Ordering Information

Product Number	Package	Marking Code	BV _{DSS}	f _{osc}	R _{DS(ON)}
FSDM311A	8DIP	DM311A	650V	67KHz	14Ω

All packages are lead free per JEDEC: J-STD-020B standard.

FPS™ is a trademark of Fairchild Semiconductor Corporation.

Typical Application & Output Power Table

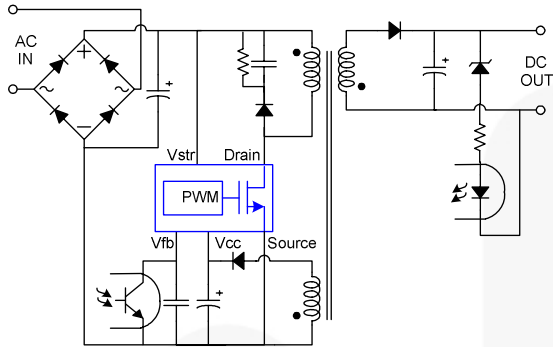

Figure 1. Typical Flyback Application

Product	Open Frame ⁽¹⁾	
	230V _{AC} ±15% ⁽²⁾	85~265V _{AC}
FSDM311A	13W	8W

Notes:

1. Maximum practical continuous power in an open-frame design with sufficient drain pattern as a heat sink, at 50°C ambient.
2. 230V_{AC} or 100/115V_{AC} with doubler.

Internal Block Diagram

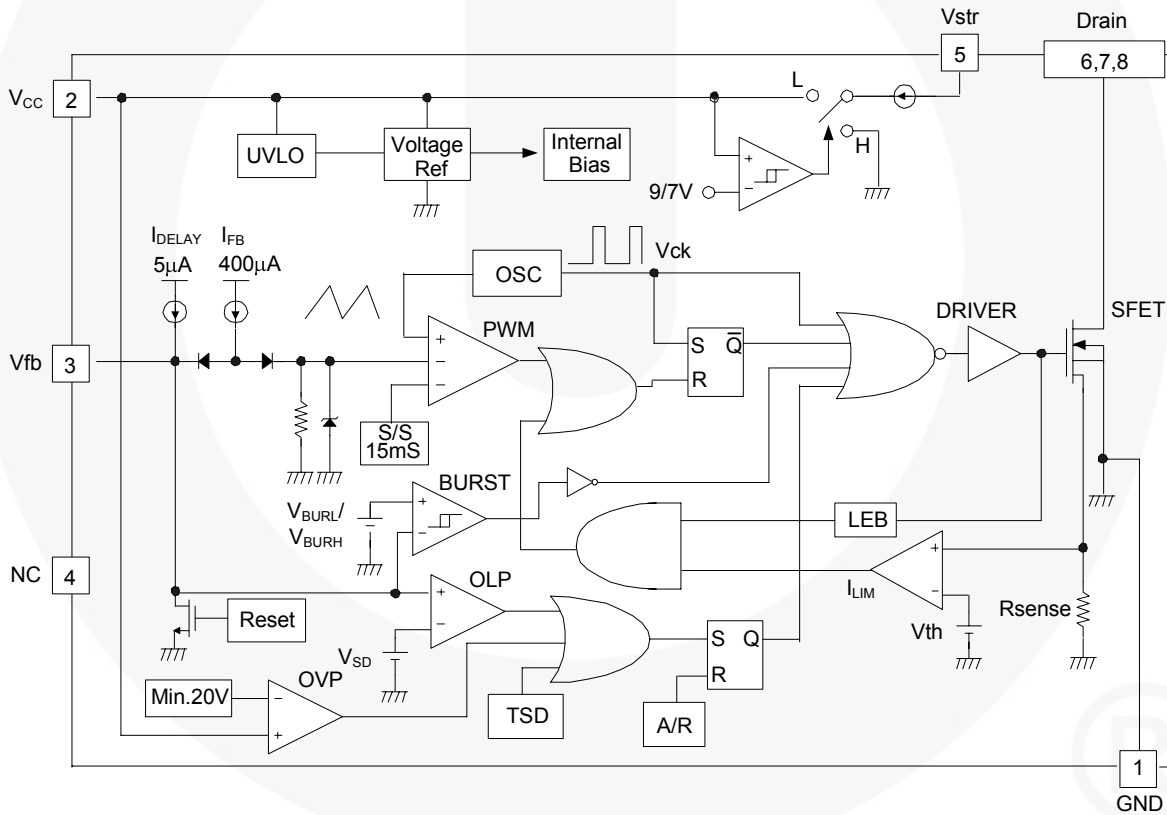

Figure 2. Functional Block Diagram

Pin Configuration

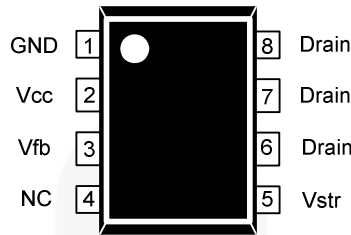

Figure 3. 8-Lead DIP Pin Assignments (Top View)

Pin Definitions

Pin #	Name	Description
1	GND	Ground. SenseFET source terminal on primary side and internal control ground.
2	Vcc	Positive supply voltage input. Although connected to an auxiliary transformer winding, current is supplied from pin 5 (Vstr) via an internal switch during start-up (see the <i>Internal Block Diagram in Figure 2</i>). It is not until V _{CC} reaches the UVLO upper threshold (9V) that the internal start-up switch opens and device power is supplied via the auxiliary transformer winding.
3	Vfb	Feedback. Inverting input to the PWM comparator with its normal input level lies between 0.5V and 2.5V. It has a 0.4mA current source connected internally, while a capacitor and optocoupler are typically connected externally. A feedback voltage of 4.5V triggers overload protection (OLP). There is a time delay while charging external capacitor C _{FB} from 3V to 4.5V using an internal 5μA current source. This time delay prevents false triggering under transient conditions, but allows the protection mechanism to operate under true overload conditions.
4	NC	No Connection.
5	Vstr	Start-up. This pin connects directly to the rectified AC line voltage source. At start-up, the internal switch supplies internal bias and charges an external storage capacitor placed between the Vcc pin and ground. Once the V _{CC} reaches 9V, the internal switch stops charging the capacitor.
6,7,8	Drain	SenseFET Drain. The drain pins are designed to connect directly to the primary lead of the transformer and are capable of switching a maximum of 650V. Minimize the length of the trace connecting these pins to the transformer to decrease leakage inductance.

Absolute Maximum Ratings

Stresses exceeding the absolute maximum ratings may damage the device. The device may not function or be operable above the recommended operating conditions and stressing the parts to these levels is not recommended. In addition, extended exposure to stresses above the recommended operating conditions may affect device reliability. The absolute maximum ratings are stress ratings only. $T_A=25^\circ\text{C}$, unless otherwise specified.

Symbol	Parameter	Value	Unit
V_{DRAIN}	Drain Pin Voltage	650	V
V_{STR}	Vstr Pin Voltage	650	V
V_{DG}	Drain-Gate Voltage	650	V
V_{GS}	Gate-Source Voltage	± 20	V
I_{DM}	Drain Current Pulsed ⁽³⁾	1.5	A
I_{D}	Continuous Drain Current ($T_C=25^\circ\text{C}$)	0.5	A
I_{D}	Continuous Drain Current ($T_C=100^\circ\text{C}$)	0.32	A
E_{AS}	Single Pulsed Avalanche Energy ⁽⁴⁾	10	mJ
V_{CC}	Supply Voltage	20	V
V_{FB}	Feedback Voltage Range	-0.3 to V_{STOP}	V
P_{D}	Total Power Dissipation	1.40	W
T_{J}	Operating Junction Temperature	Internally limited	$^\circ\text{C}$
T_{A}	Operating Ambient Temperature	-25 to +85	$^\circ\text{C}$
T_{STG}	Storage Temperature	-55 to +150	$^\circ\text{C}$

Notes:

- Repetitive rating: Pulse width is limited by maximum junction temperature.
- $L = 24\text{mH}$, starting $T_{\text{J}} = 25^\circ\text{C}$

Thermal Impedance

$T_A=25^\circ\text{C}$, unless otherwise specified.

Symbol	Parameter	Value	Unit
8DIP			
θ_{JA}	Junction-to-Ambient Thermal Impedance ⁽⁵⁾	88.84	$^\circ\text{C/W}$
θ_{JC}	Junction-to-Case Thermal Impedance ⁽⁶⁾	13.94	$^\circ\text{C/W}$

Notes:

- Free standing with no heatsink; without copper clad. (Measurement Condition – just before junction temperature T_{J} enters into OTP).
- Measured on the DRAIN pin close to plastic interface.
- All items are tested with the standards JESD 51-2 and 51-10 (DIP).

Electrical Characteristics

T_A=25°C unless otherwise specified.

Symbol	Parameter	Conditions	Min.	Typ.	Max.	Unit
SENSEFET SECTION						
I _{DSS}	Zero-Gate-Voltage Drain Current	V _{DS} =650V, V _{GS} =0V			25	mA
		V _{DS} =520V, V _{GS} =0V, T _C =125°C			200	
R _{DS(ON)}	Drain-Source On-State Resistance ⁽⁸⁾	V _{GS} =10V, I _D =0.5A		14	19	Ω
g _{fs}	Forward Trans-Conductance	V _{DS} =50V, I _D =0.5A	1.0	1.3		S
C _{ISS}	Input Capacitance	V _{GS} =0V, V _{DS} =25V, f=1MHz		162		pF
C _{OSS}	Output Capacitance			18		
C _{RSS}	Reverse Transfer Capacitance			3.8		
t _{d(on)}	Turn-On Delay Time	V _{DS} =325V, I _D =1.0A		9.5		ns
t _r	Rise Time			19		
t _{d(off)}	Turn-Off Delay Time			33		
t _f	Fall Time			42		
Q _g	Total Gate Charge	V _{GS} =10V, I _D =1.0A, V _{DS} =325V		7.0		nC
Q _{gs}	Gate-Source Charge			3.1		
Q _{gd}	Gate-Drain (Miller) Charge			0.4		
CONTROL SECTION						
f _{OSC}	Switching Frequency		61	67	73	KHz
Δf _{OSC}	Switching Frequency Variation ⁽⁹⁾	-25°C ≤ T _A ≤ 85°C		±5	±10	%
D _{MAX}	Maximum Duty Cycle		60	67	74	%
V _{START}	UVLO Threshold Voltage	V _{FB} =GND	8	9	10	V
V _{STOP}		V _{FB} =GND	6	7	8	V
I _{FB}	Feedback Source Current	0V ≤ V _{FB} ≤ 3V	0.35	0.40	0.45	mA
t _{S/S}	Internal Soft-Start Time		10	15	20	ms
V _{REF}	Reference Voltage ⁽¹⁰⁾		4.2	4.5	4.8	V
ΔV _{REF} /ΔT	Reference Voltage Variation with Temperature ^(9, 10)	-25°C ≤ T _A ≤ 85°C		0.3	0.6	mV/°C
BURST MODE SECTION						
V _{BURH}	Burst Mode Voltage	T _J =25°C	0.6	0.7	0.8	V
V _{BURL}			0.45	0.55	0.65	V
V _{BUR(HYS)}		Hysteresis		150		mV
PROTECTION SECTION						
I _{LIM}	Peak Current Limit	di/dt=90mA/μs	0.500	0.575	0.650	A
T _{SD}	Thermal Shutdown Temperature ⁽¹⁰⁾		125	145		°C
V _{SD}	Shutdown Feedback Voltage		4.0	4.5	5.0	V
V _{OVP}	Over-Voltage Protection		20			V
I _{DELAY}	Shutdown Delay Current	3V ≤ V _{FB} ≤ V _{SD}	4	5	6	μA
TOTAL DEVICE SECTION						
I _{OP}	Operating Supply Current (control part only)	V _{CC} ≤ 16V		1.5	3.0	mA
I _{CH}	Start-up Charging Current	V _{CC} =0V, V _{STR} =50V	450	550	650	μA

Notes:

8. Pulse test: Pulse width ≤ 300μs, duty ≤ 2%.
9. These parameters, although guaranteed, are tested in EDS (wafer test) process.
10. These parameters, although guaranteed, are not 100% tested in production.

Typical Performance Characteristics

Normalized at $T_A = 25^\circ\text{C}$.

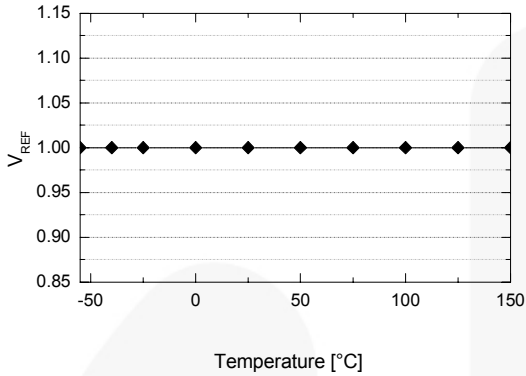

Figure 4. Reference Voltage (V_{REF}) vs. T_A

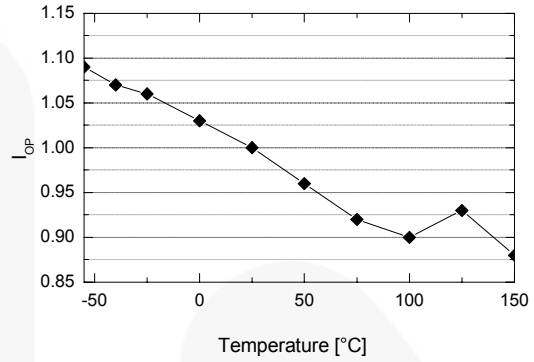

Figure 5. Operating Supply Current (I_{OP}) vs. T_A

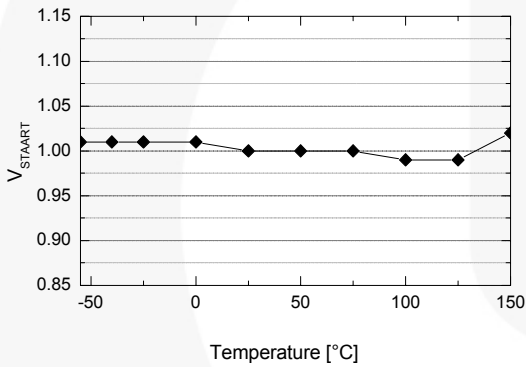

Figure 6. Start Threshold Voltage (V_{START}) vs. T_A

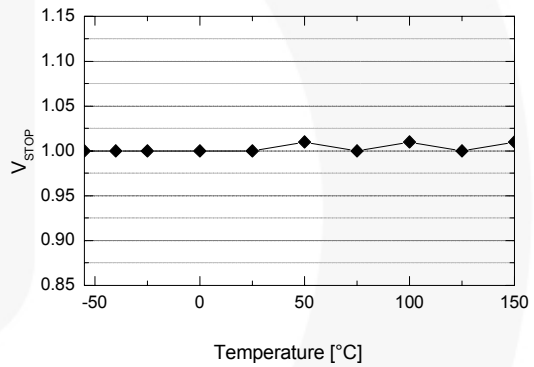

Figure 7. Stop Threshold Voltage (V_{STOP}) vs. T_A

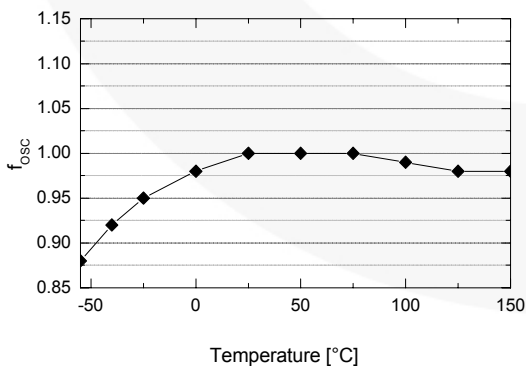

Figure 8. Operating Frequency (f_{osc}) vs. T_A

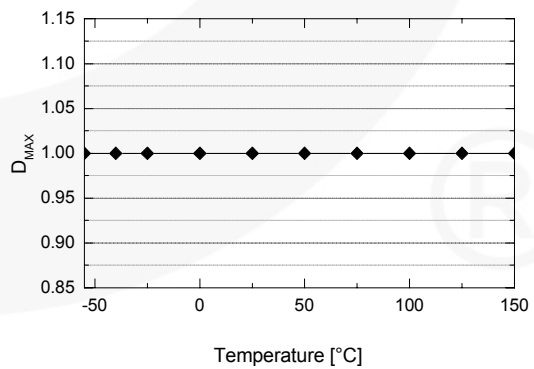

Figure 9. Maximum Duty Cycle (D_{MAX}) vs. T_A

Typical Performance Characteristics (Continued)

Normalized at $T_A = 25^\circ\text{C}$.

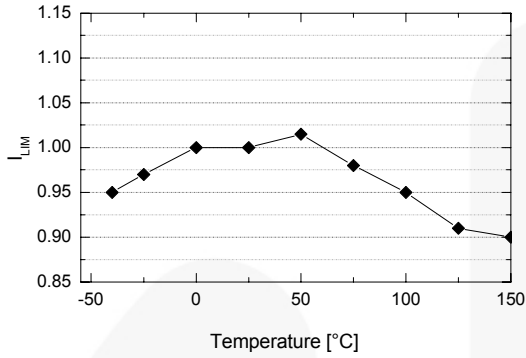

Figure 10. Peak Current Limit (I_{LIM}) vs. T_A

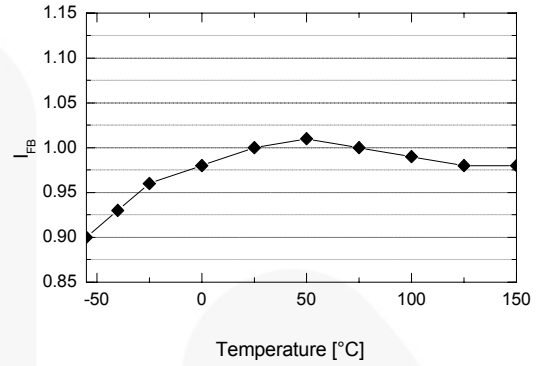

Figure 11. Feedback Source Current (I_{FB}) vs. T_A

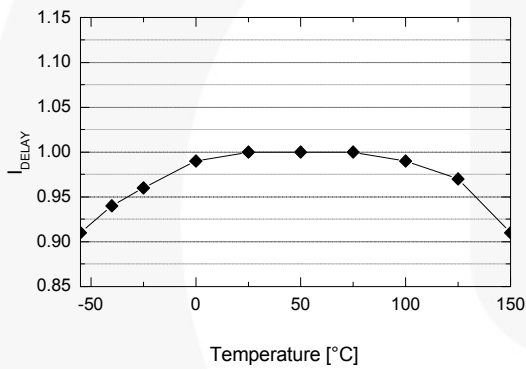

Figure 12. Shutdown Delay Current (I_{DELAY}) vs. T_A

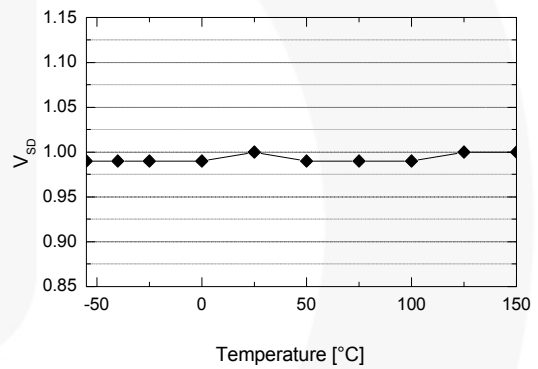

Figure 13. Shutdown Feedback Voltage (V_{SD}) vs. T_A

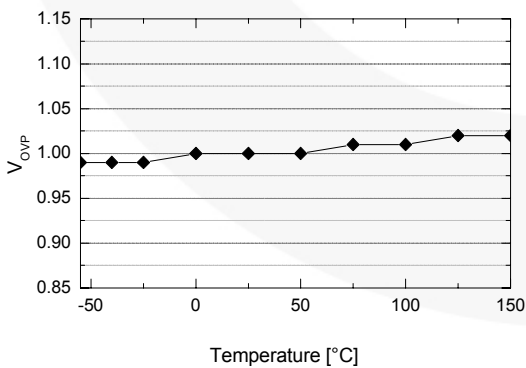

Figure 14. Over-Voltage Protection (V_{OVP}) vs. T_A

Functional Description

1. Start-up: At start-up, the internal high-voltage current source supplies the internal bias and charges the external V_{CC} capacitor, as shown in Figure 15. When V_{CC} reaches 9V, the device starts switching and the internal high-voltage current source stops charging the capacitor. The device is in normal operation provided V_{CC} does not drop below 7V. After start-up, the bias is supplied from the auxiliary transformer winding.

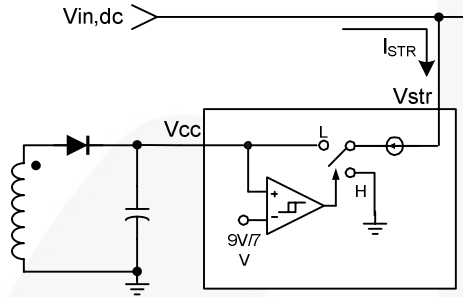

Figure 15. Internal Start-up Circuit

Calculating the V_{CC} capacitor is an important step in design with the FSDM311A. At initial start-up, the maximum value of start operating current I_{START} is about $100\mu A$, which supplies current to UVLO and V_{REF} blocks. The charging current I_{VCC} of the V_{CC} capacitor is equal to $I_{STR} - 100\mu A$. After V_{CC} reaches the UVLO start voltage, only the bias winding supplies V_{CC} current to the device. When the bias winding voltage is not sufficient, the V_{CC} level decreases to the UVLO stop voltage and the internal current source is activated again to charge the V_{CC} capacitor. To prevent this V_{CC} fluctuation (charging/discharging), the V_{CC} capacitor should be chosen for a value between $10\mu F$ and $47\mu F$.

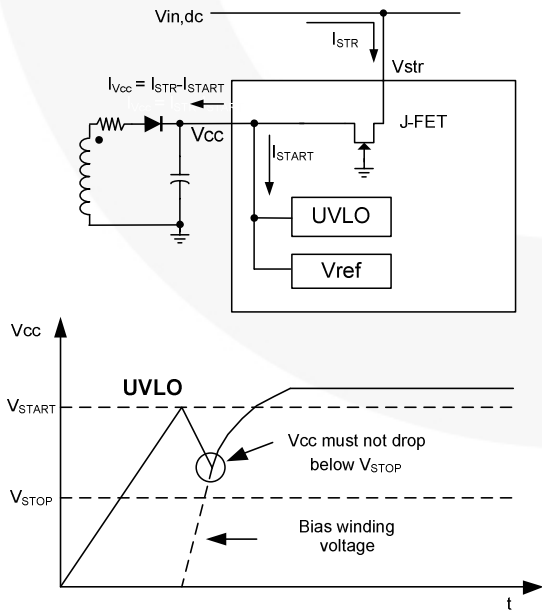

Figure 16. Charging V_{CC} Capacitor through V_{STR}

2. Feedback Control: The FSDM311A is the voltage-mode controlled device, as shown in Figure 17. Usually, an opto-coupler and shunt regulator, such as KA431, are used to implement the feedback network. The feedback voltage is compared with an internally generated sawtooth waveform that directly controls the duty cycle. When the shunt regulator reference pin voltage exceeds the internal reference voltage of 2.5V, the opto-coupler LED current increases, the feedback voltage V_{FB} is pulled down, and it reduces the duty cycle. This happens when the input voltage increases or the output load decreases.

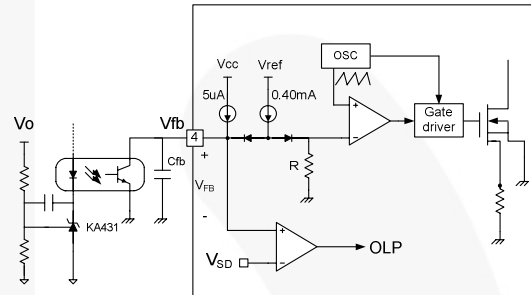

Figure 17. PWM and Feedback Circuit

3. Leading-Edge Blanking (LEB): At the instant the internal SenseFET is turned on, the primary-side capacitance and secondary-side rectifier diode reverse recovery typically cause a high-current spike through the SenseFET. Excessive voltage across the R_{SENSE} resistor leads to incorrect pulse-by-pulse current limit protection. To avoid this, a leading-edge blanking (LEB) circuit disables pulse-by-pulse current limit protection block for a fixed time (t_{LEB}) after the SenseFET turns on.

4. Protection Circuit: The FSDM311A has several protective functions, such as overload protection (OLP), over-voltage protection (OVP), under-voltage lockout (UVLO), and thermal shutdown (TSD). Because these protection circuits are fully integrated in the IC without external components, the reliability is improved without increasing costs. Once a fault condition occurs, switching is terminated and the SenseFET remains off, which causes V_{CC} to fall. When V_{CC} reaches the UVLO stop voltage, V_{STOP} (7V), the protection is reset and the internal high-voltage current source charges the V_{CC} capacitor via the V_{STR} pin. When V_{CC} reaches the UVLO start voltage, V_{START} (9V), the device resumes normal operation. In this manner, the auto-restart can alternately enable and disable the switching of the power SenseFET until the fault condition is eliminated.

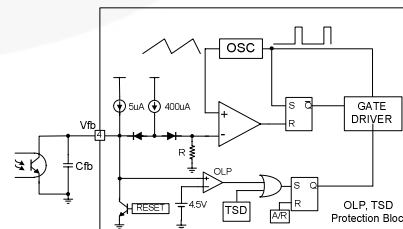

Figure 18. Protection Block

4.1 Overload Protection (OLP): Overload is defined as the load current exceeding a pre-set level due to an unexpected event. In this situation, the protection circuit should be activated to protect the SMPS. However, even when the SMPS is operating normally, the overload protection (OLP) circuit can be activated during the load transition. To avoid this undesired operation, the OLP circuit is designed to be activated after a specified time to determine whether it is a transient situation or an overload situation. If the output consumes more than the maximum power determined by I_{LIM} , the output voltage (V_O) decreases below its rating voltage. This reduces the current through the opto-coupler LED, which also reduces the opto-coupler transistor current, thus increasing the feedback voltage (V_{FB}). If V_{FB} exceeds 3V, the feedback input diode is blocked and the $5\mu A$ current source (I_{DELAY}) starts to charge C_{FB} slowly up to V_{CC} . In this condition, V_{FB} increases until it reaches 4.5V, when the switching operation is terminated, as shown in Figure 19. The shutdown delay time is the time required to charge C_{FB} from 3V to 4.5V with $5\mu A$ current source.

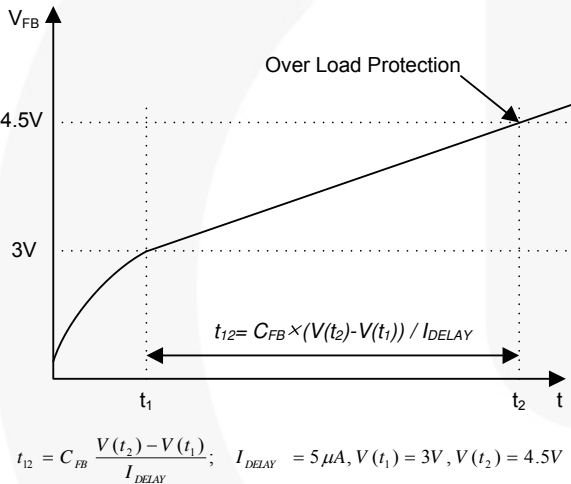

Figure 19. Overload Protection (OLP)

4.2 Thermal Shutdown (TSD): The SenseFET and the control IC are integrated, making it easier for the control IC to detect the temperature of the SenseFET. When the temperature exceeds approximately 145°C, thermal shutdown is activated.

5. Soft-Start: The FPS has an internal soft-start circuit that slowly increases the feedback voltage with the SenseFET current right after it starts up. The typical soft-start time is 15ms, as shown in Figure 20, where progressive increment of the SenseFET current is allowed during the start-up phase. The soft-start circuit progressively increases current limits to establish proper working conditions for transformers, inductors, capacitors, and switching devices. It also helps to prevent transformer saturation and reduces the stress on the secondary diode.

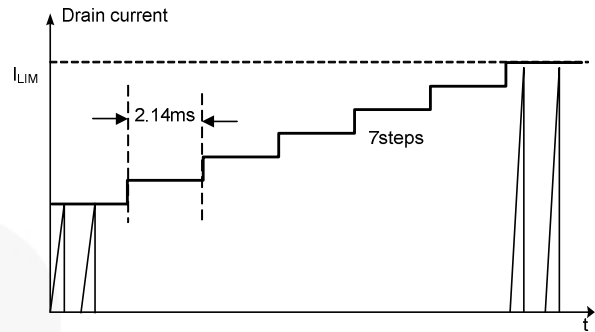

Figure 20. Internal Soft-Start

6. Burst Operation: To minimize the power dissipation in standby mode, the FSDM311A enters burst mode operation. As the load decreases, the feedback voltage decreases. The device automatically enters burst mode when the feedback voltage drops below V_{BURL} (0.55V). At this point, switching stops and the output voltages start to drop. This causes the feedback voltage to rise. Once it passes V_{BURH} (0.70V), switching starts again. The feedback voltage falls and the process repeats. Burst mode operation alternately enables and disables switching of the power MOSFET to reduce the switching loss in standby mode.

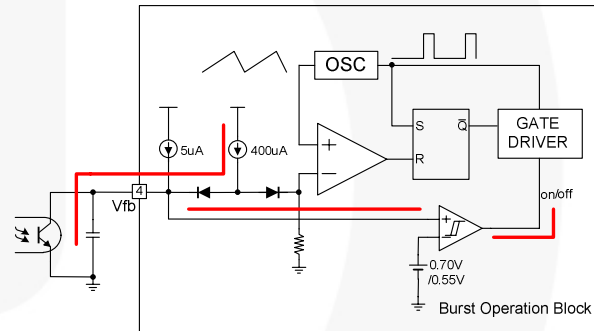

Figure 21. Burst Operation Block

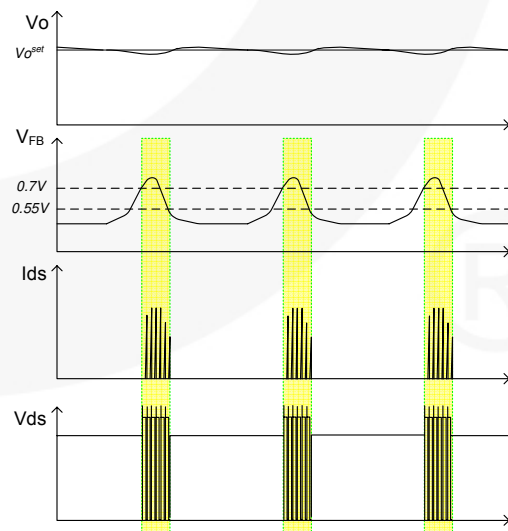

Figure 22. Burst Operation Function

Application Information

Methods of Reducing Audible Noise

Switching-mode power converters have electronic and magnetic components that generate audible noise when the operating frequency is in the range of 20~20,000Hz. Even though they operate above 20kHz, they can make noise, depending on the load condition. Designers can employ several methods to reduce noise.

Glue or Varnish

The most common method involves using glue or varnish to tighten magnetic components. The motion of core, bobbin, and coil; and the chattering or magnetostriction of core, can cause the transformer to produce audible noise. The use of rigid glue and varnish helps reduce transformer noise, but can crack the core. This is because sudden changes in the ambient temperature cause the core and the glue to expand or shrink at a different rate.

Ceramic Capacitor

Using a film capacitor instead of a ceramic capacitor as a snubber capacitor is another noise-reduction solution. Some dielectric materials show a piezoelectric effect, depending on the electric field intensity. A snubber capacitor becomes one of the most significant sources of audible noise. It is possible to use a Zener clamp circuit instead of an RCD snubber for higher efficiency as well as lower audible noise.

Adjusting Sound Frequency

Moving the fundamental frequency out of the 2~4kHz range another method of reducing perceptible noise. Generally, humans are more sensitive to noise in the range of 2~4kHz. When the fundamental frequency of noise is located in this range, it is perceived as louder, although the noise intensity level is identical (refer to Figure 23, Equal Loudness Curves).

If burst-mode operation is suspected to be a source of noise, this method may be helpful. If the frequency of burst-mode operation lies between 2~4 kHz, adjusting the feedback loop can shift the frequency. To reduce the burst operation frequency, increase a feedback gain capacitor (C_F), opto-coupler supply resistor (R_D), and feedback capacitor (C_B); and decrease a feedback gain resistor (R_F), as shown in Figure 24.

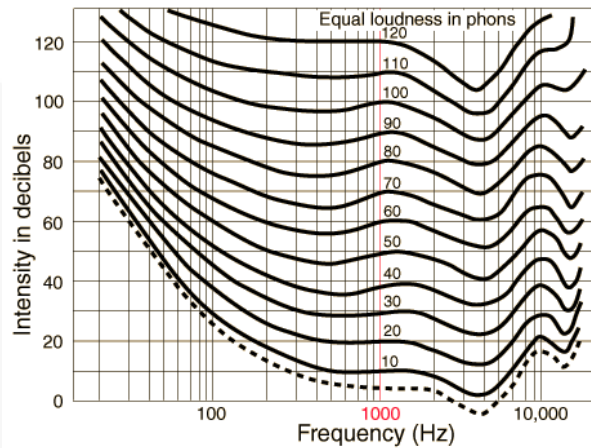

Figure 23. Equal Loudness Curves

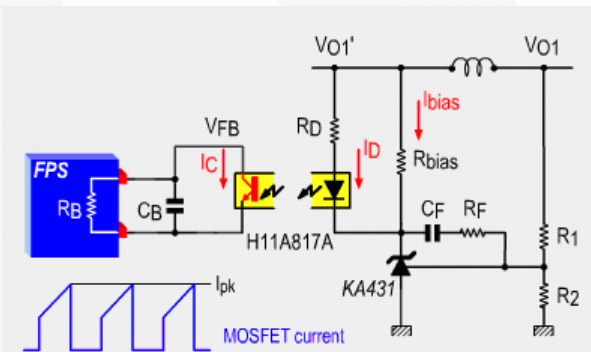
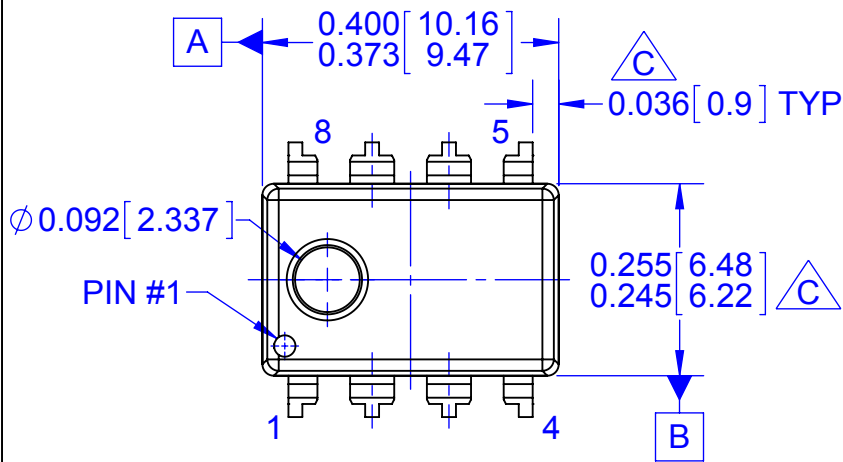

Figure 24. Typical Feedback Network of FPS™

Reference Materials

- [AN-4134: Design Guidelines for Off-line Forward Converters Using Fairchild Power Switch \(FPS™\)](#)
- [AN-4137: Design Guidelines for Off-line Flyback Converters Using Fairchild Power Switch \(FPS™\)](#)
- [AN-4138: Design Considerations for Battery Charger Using Green Mode Fairchild Power Switch \(FPS™\)](#)
- [AN-4140: Transformer Design Consideration for Off-line Flyback Converters Using Fairchild Power Switch \(FPS™\)](#)
- [AN-4141: Troubleshooting and Design Tips for Fairchild Power Switch \(FPS™\) Flyback Applications](#)
- [AN-4147: Design Guidelines for RCD Snubber of Flyback](#)
- [AN-4148: Audible Noise Reduction Techniques for FPS™ Applications](#)



TOP VIEW, OPTION 1

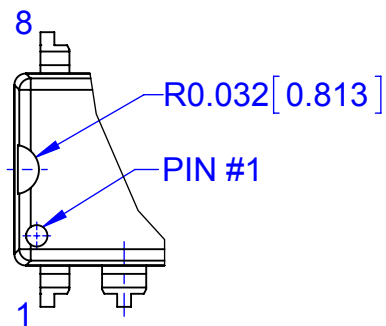

TOP VIEW, OPTION 2

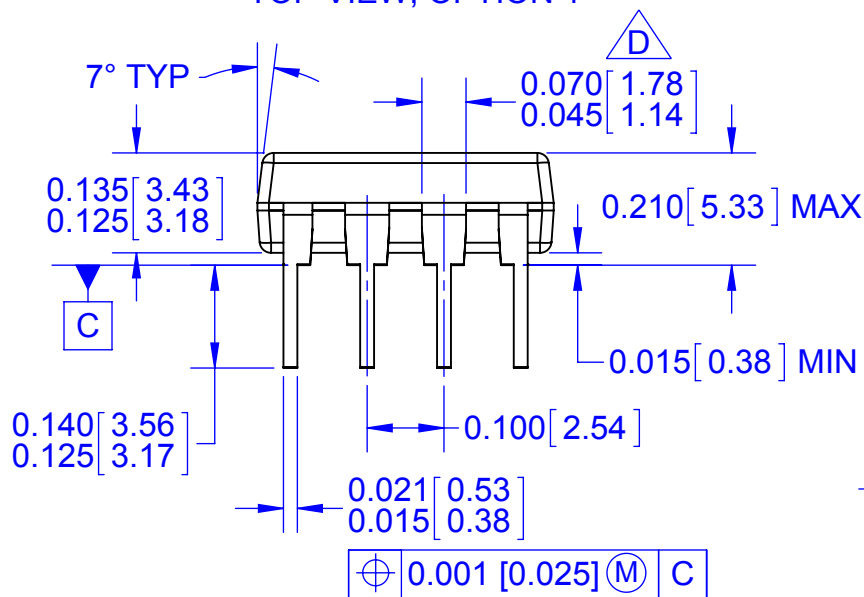

FRONT VIEW

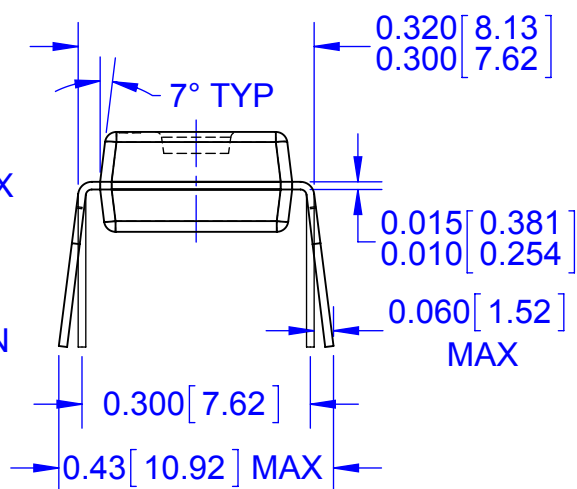

SIDE VIEW

NOTES:

- A. CONFORMS TO JEDEC MS-001, VARIATION BA
- B. CONTROLLING DIMENSIONS ARE IN INCHES.
REFERENCE DIMENSIONS ARE IN MILLIMETERS.

C DOES NOT INCLUDE MOLD FLASH OR PROTRUSIONS.
MOLD FLASH OR PROTRUSIONS SHALL NOT EXCEED
0.010 INCHES OR 0.25MM.

D DOES NOT INCLUDE DAMBAR PROTRUSIONS.
DAMBAR PROTRUSIONS SHALL NOT EXCEED 0.010
INCHES OR 0.25MM.

E. DIMENSIONING AND TOLERANCING PER ASME
Y14.5M-2009

F. DRAWING FILENAME: MKT-N08Erev8



ON Semiconductor and  are trademarks of Semiconductor Components Industries, LLC dba ON Semiconductor or its subsidiaries in the United States and/or other countries. ON Semiconductor owns the rights to a number of patents, trademarks, copyrights, trade secrets, and other intellectual property. A listing of ON Semiconductor's product/patent coverage may be accessed at www.onsemi.com/site/pdf/Patent-Marking.pdf. ON Semiconductor reserves the right to make changes without further notice to any products herein. ON Semiconductor makes no warranty, representation or guarantee regarding the suitability of its products for any particular purpose, nor does ON Semiconductor assume any liability arising out of the application or use of any product or circuit, and specifically disclaims any and all liability, including without limitation special, consequential or incidental damages. Buyer is responsible for its products and applications using ON Semiconductor products, including compliance with all laws, regulations and safety requirements or standards, regardless of any support or applications information provided by ON Semiconductor. "Typical" parameters which may be provided in ON Semiconductor data sheets and/or specifications can and do vary in different applications and actual performance may vary over time. All operating parameters, including "Typicals" must be validated for each customer application by customer's technical experts. ON Semiconductor does not convey any license under its patent rights nor the rights of others. ON Semiconductor products are not designed, intended, or authorized for use as a critical component in life support systems or any FDA Class 3 medical devices or medical devices with a same or similar classification in a foreign jurisdiction or any devices intended for implantation in the human body. Should Buyer purchase or use ON Semiconductor products for any such unintended or unauthorized application, Buyer shall indemnify and hold ON Semiconductor and its officers, employees, subsidiaries, affiliates, and distributors harmless against all claims, costs, damages, and expenses, and reasonable attorney fees arising out of, directly or indirectly, any claim of personal injury or death associated with such unintended or unauthorized use, even if such claim alleges that ON Semiconductor was negligent regarding the design or manufacture of the part. ON Semiconductor is an Equal Opportunity/Affirmative Action Employer. This literature is subject to all applicable copyright laws and is not for resale in any manner.

PUBLICATION ORDERING INFORMATION

LITERATURE FULFILLMENT:

Literature Distribution Center for ON Semiconductor
19521 E. 32nd Pkwy, Aurora, Colorado 80011 USA
Phone: 303-675-2175 or 800-344-3860 Toll Free USA/Canada
Fax: 303-675-2176 or 800-344-3867 Toll Free USA/Canada
Email: orderlit@onsemi.com

N. American Technical Support: 800-282-9855 Toll Free
USA/Canada
Europe, Middle East and Africa Technical Support:
Phone: 421 33 790 2910
Japan Customer Focus Center
Phone: 81-3-5817-1050

ON Semiconductor Website: www.onsemi.com
Order Literature: <http://www.onsemi.com/orderlit>
For additional information, please contact your local
Sales Representative