



Chipsmall Limited consists of a professional team with an average of over 10 year of expertise in the distribution of electronic components. Based in Hongkong, we have already established firm and mutual-benefit business relationships with customers from,Europe,America and south Asia,supplying obsolete and hard-to-find components to meet their specific needs.

With the principle of “Quality Parts,Customers Priority,Honest Operation,and Considerate Service”,our business mainly focus on the distribution of electronic components. Line cards we deal with include Microchip,ALPS,ROHM,Xilinx,Pulse,ON,Everlight and Freescale. Main products comprise IC,Modules,Potentiometer,IC Socket,Relay,Connector.Our parts cover such applications as commercial,industrial, and automotives areas.

We are looking forward to setting up business relationship with you and hope to provide you with the best service and solution. Let us make a better world for our industry!



Contact us

Tel: +86-755-8981 8866 Fax: +86-755-8427 6832

Email & Skype: info@chipsmall.com Web: www.chipsmall.com

Address: A1208, Overseas Decoration Building, #122 Zhenhua RD., Futian, Shenzhen, China



THIS DRAWING IS UNPUBLISHED. RELEASED FOR PUBLICATION 1437565-5, 1437565-5
 © COPYRIGHT 1437565-5 ALL RIGHTS RESERVED.

LOC	DIST	REVISIONS			
P	LTR	DESCRIPTION	DATE	DWN	APVD
AD	00	E2 REVISED PER ECO-11-004587	11MAR11	RK	HMR

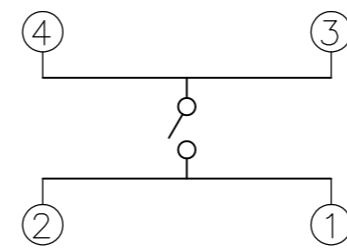
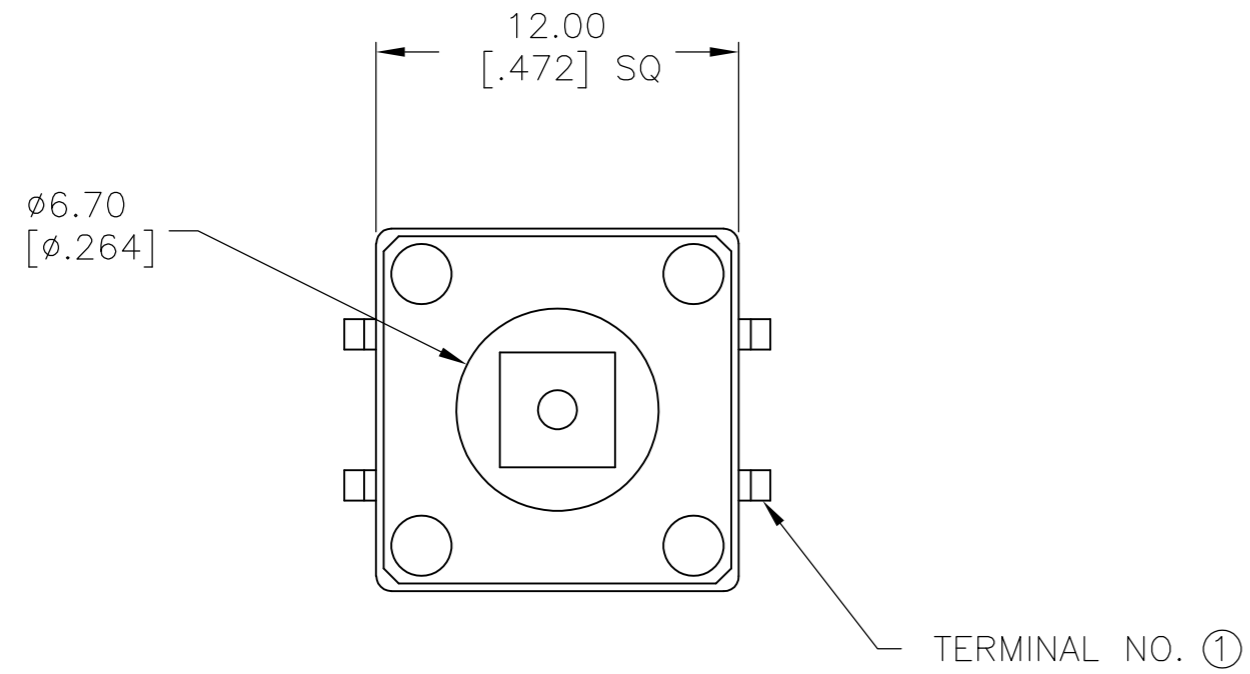

CIRCUIT DIAGRAM

NOTE: TERMINAL NUMBERS ARE FOR REFERENCE ONLY AND DO NOT APPEAR ON SWITCHES.

SPECIFICATIONS:

MATERIALS:

CASE: PBT G30, 94HB, BLACK.
 COVER: PET FILM.
 ACTUATOR BUTTON: ACETAL, BLACK.
 MOVING CONTACT: PHOS.BRONZE, SILVER CLAD.
 FIXED CONTACT/TERMINAL: BRASS. SILVER PLATE.

ELECTRICAL:

MAX CONTACT RATING: 50MILLIAMPS@24V DC
 MIN CONTACT RATING: 10MICROAMPS@1V DC
 CONTACT RESISTANCE: 100 MILLIOHMS MAX.
 INSULATION RESISTANCE: 100 MEGOHMS MIN. @ 100 VDC.
 DIELECTRIC STRENGTH: 500 VAC
 LIFE EXPECTANCY: 100,000 CYCLES MIN.

MECHANICAL:

ACTUATION FORCE: 160 ±30 GRAMS.
 ACTUATION TRAVEL: 0.30mm (.012 in.) APPROX.

ENVIRONMENTAL:

OPERATING TEMPERATURE: -35°C TO +85°C.
 STORAGE TEMPERATURE: -35°C TO +85°C.
 RESISTANCE TO SOLDER HEAT PER 109-202, COND B 265°C FOR 10 SECONDS

SOLDERABILITY:

SPECIFICATION EIA-364-52, CLASS II, CATEGORY 1

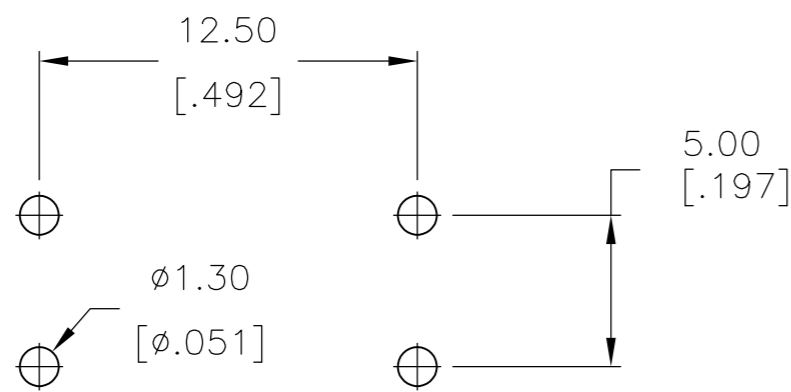
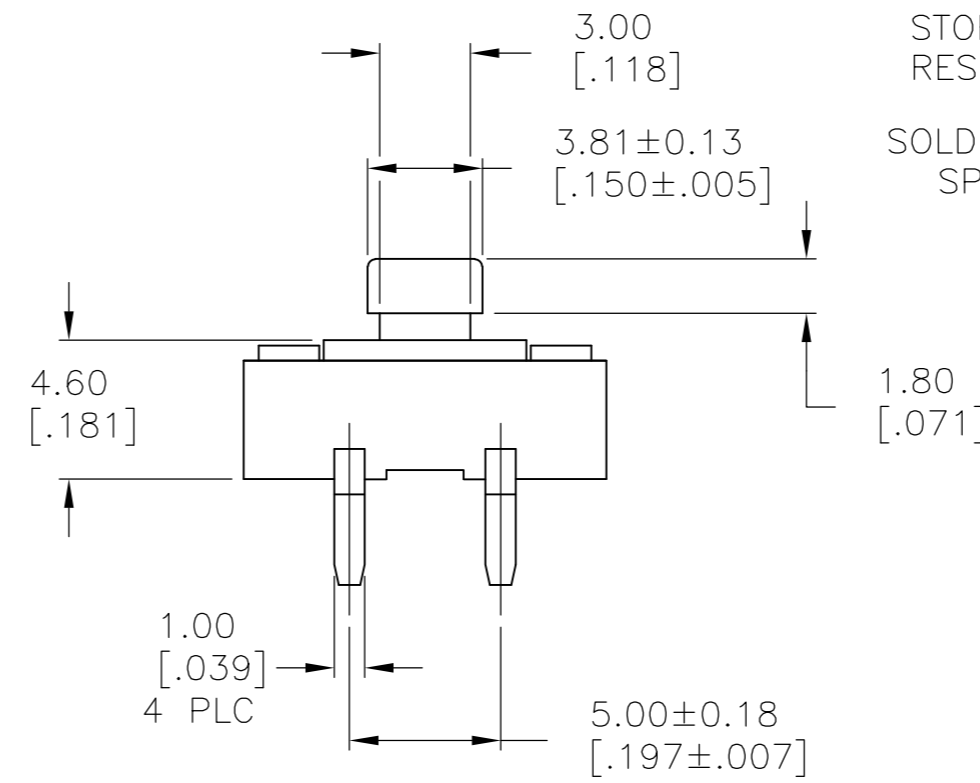
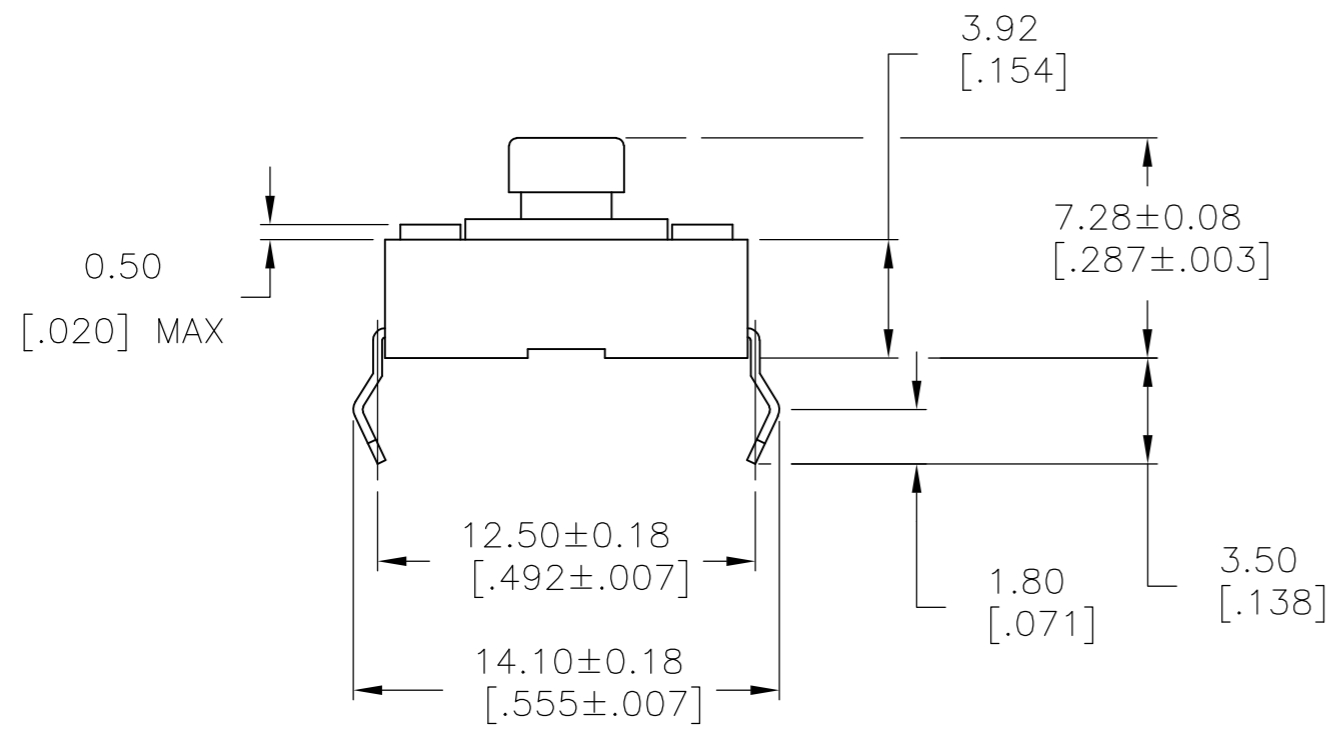

RECOMMENDED HOLE LAYOUT

TOLERANCE ±.002 UNLESS OTHERWISE NOTED

260±50g	RED	FSM103A	1571627-1
160±50g	BLACK	FSM103	1437565-5
ACTUATOR FORCE	ACTUATOR COLOR	FORMER T&B PART NUMBER	PART NUMBER

THIS DRAWING IS A CONTROLLED DOCUMENT.		DWN	R BROWN	12FEB04																					
DIMENSIONS: mm [INCHES]		CHK	M SARVER	12FEB04																					
TOLERANCES UNLESS OTHERWISE SPECIFIED:		APVD	M SARVER	12FEB04																					
<table border="1"> <tr><td>0 PLC</td><td>±</td><td>-</td></tr> <tr><td>1 PLC</td><td>±</td><td>-</td></tr> <tr><td>2 PLC</td><td>±</td><td>0.30[.012]</td></tr> <tr><td>3 PLC</td><td>±</td><td>-</td></tr> <tr><td>4 PLC</td><td>±</td><td>-</td></tr> <tr><td>ANGLES</td><td>±</td><td>-</td></tr> <tr><td>FINISH</td><td>±</td><td>-</td></tr> </table>		0 PLC	±	-		1 PLC	±	-	2 PLC	±	0.30[.012]	3 PLC	±	-	4 PLC	±	-	ANGLES	±	-	FINISH	±	-	PRODUCT SPEC	NAME
0 PLC	±	-																							
1 PLC	±	-																							
2 PLC	±	0.30[.012]																							
3 PLC	±	-																							
4 PLC	±	-																							
ANGLES	±	-																							
FINISH	±	-																							
MATERIAL	-	APPLICATION SPEC	-	SIZE	A2																				
-		WEIGHT	-	CAGE CODE	-																				
-		CUSTOMER DRAWING	-	DRAWING NO	C=1437565-5																				
-		SCALE	4:1	SHEET	1 of 1																				
-		REV	E2	RESTRICTED TO	-																				