



Chipsmall Limited consists of a professional team with an average of over 10 year of expertise in the distribution of electronic components. Based in Hongkong, we have already established firm and mutual-benefit business relationships with customers from,Europe,America and south Asia,supplying obsolete and hard-to-find components to meet their specific needs.

With the principle of “Quality Parts,Customers Priority,Honest Operation,and Considerate Service”,our business mainly focus on the distribution of electronic components. Line cards we deal with include Microchip,ALPS,ROHM,Xilinx,Pulse,ON,Everlight and Freescale. Main products comprise IC,Modules,Potentiometer,IC Socket,Relay,Connector.Our parts cover such applications as commercial,industrial, and automotives areas.

We are looking forward to setting up business relationship with you and hope to provide you with the best service and solution. Let us make a better world for our industry!



Contact us

Tel: +86-755-8981 8866 Fax: +86-755-8427 6832

Email & Skype: info@chipsmall.com Web: www.chipsmall.com

Address: A1208, Overseas Decoration Building, #122 Zhenhua RD., Futian, Shenzhen, China



THIS DRAWING IS UNPUBLISHED. RELEASED FOR PUBLICATION 2-1437565-7, 2-1437565-7
 © COPYRIGHT 2-1437565-7 ALL RIGHTS RESERVED.

REVISIONS					
P	LTR	DESCRIPTION	DATE	DWN	APVD
	A5	REVISED PER ECO-16-018632	05APR2017	SK	PO

SPECIFICATIONS:

MATERIALS:

CASE, PPS, UL94 V-0, BROWN
 ACTUATOR, NYLON, UL94V-0, SEE P/N TABLE FOR FINISH
 COVER, STEEL, TIN FINISH
 TERMINAL/FIXED CONTACT, COPPER ALLOY-SILVER FINISH
 MOVING CONTACT, STAINLESS STEEL-SILVER FINISH

ELECTRICAL:

MAX CONTACT RATING, 50MILLIAMP@24V DC
 MIN CONTACT RATING, 1MICROAMP@1V DC
 CONTACT RESISTANCE, 100 MILLIOHMS MAX
 INSULATION RESISTANCE, 100 MEGOHM MIN.
 DIELECTRIC STRENGTH, 500 V AC FOR 1 MINUTE
 LIFE EXPECTANCY, 1,000,000 CYCLES

MECHANICAL:

ACTUATION FORCE, SEE P/N TABLE
 ACTUATION TRAVEL, 0.25 +0.20/-0.10
 LIFE EXPECTANCY, 1,000,000,
 (2 CYCLES PER SECOND AND 150% ACTUATION FORCE)

ENVIRONMENTAL:

OPERATING TEMPERATURE, -40 TO +105° C
 STORAGE TEMPERATURE, -40 TO +105° C
 SOLDERABILITY, EIA-RS-186-9E, OR MIL-STD-202F
 RESISTANCE TO SOLDER HEAT, 260° C FOR 10SEC-PER 109-201, COND B
 1. NO CHANGE IN INITIAL ELECTRICAL AND MECHANICAL CHARACTERISTICS

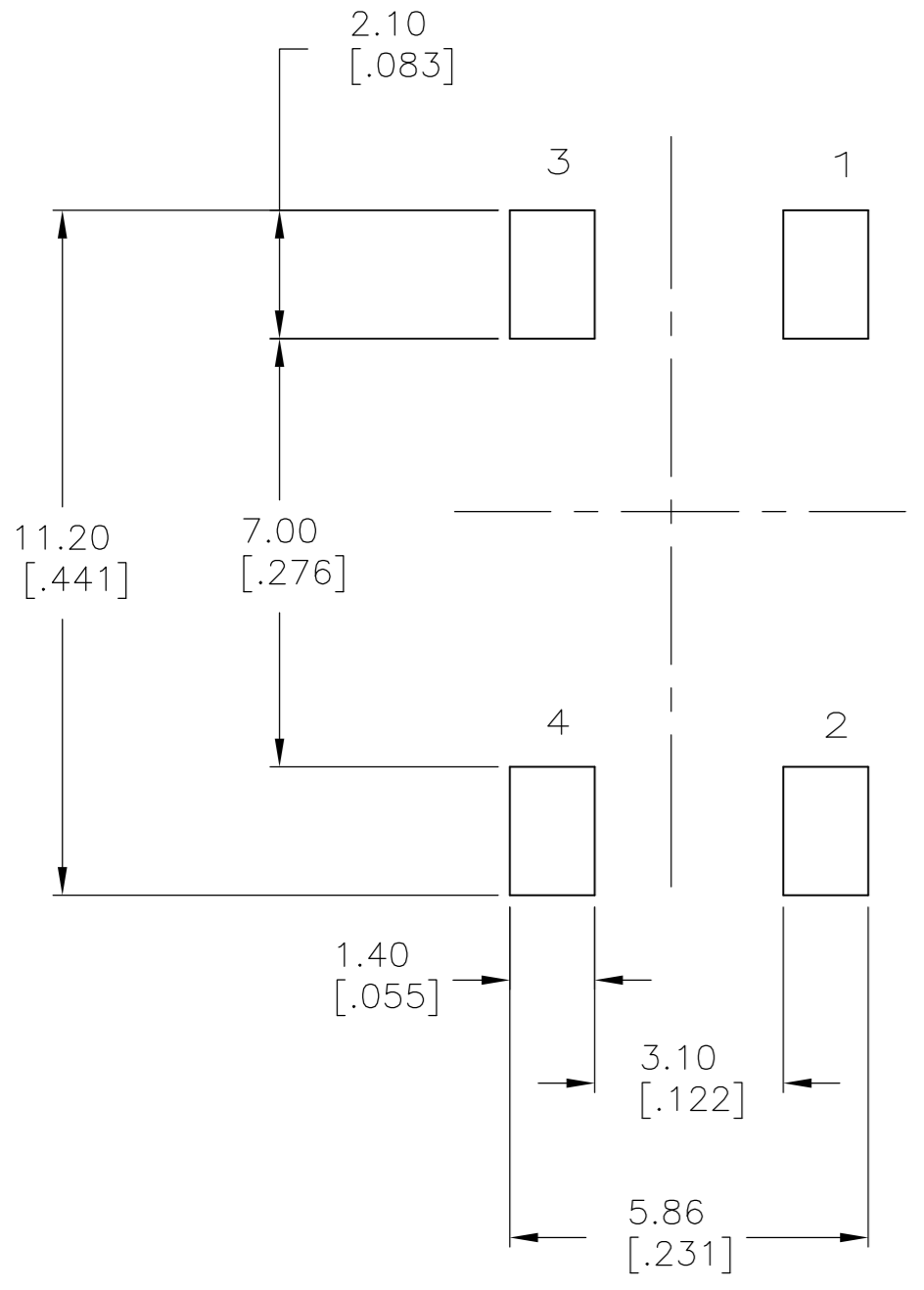
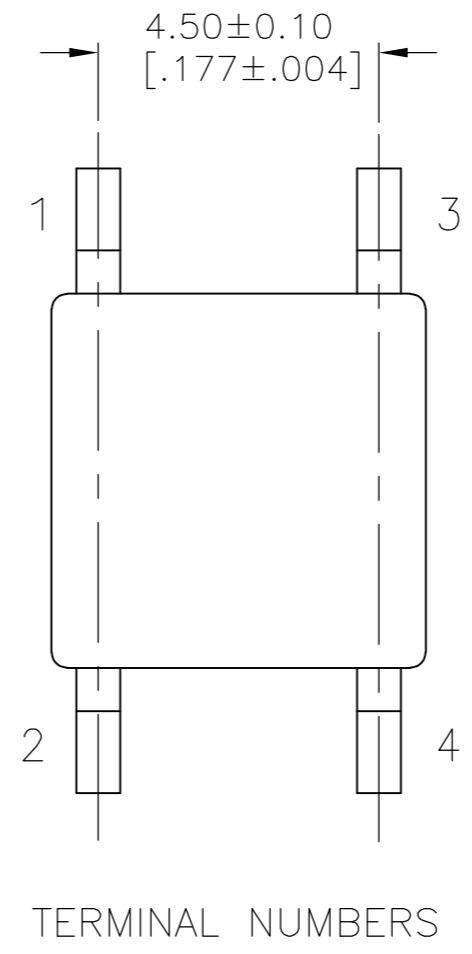
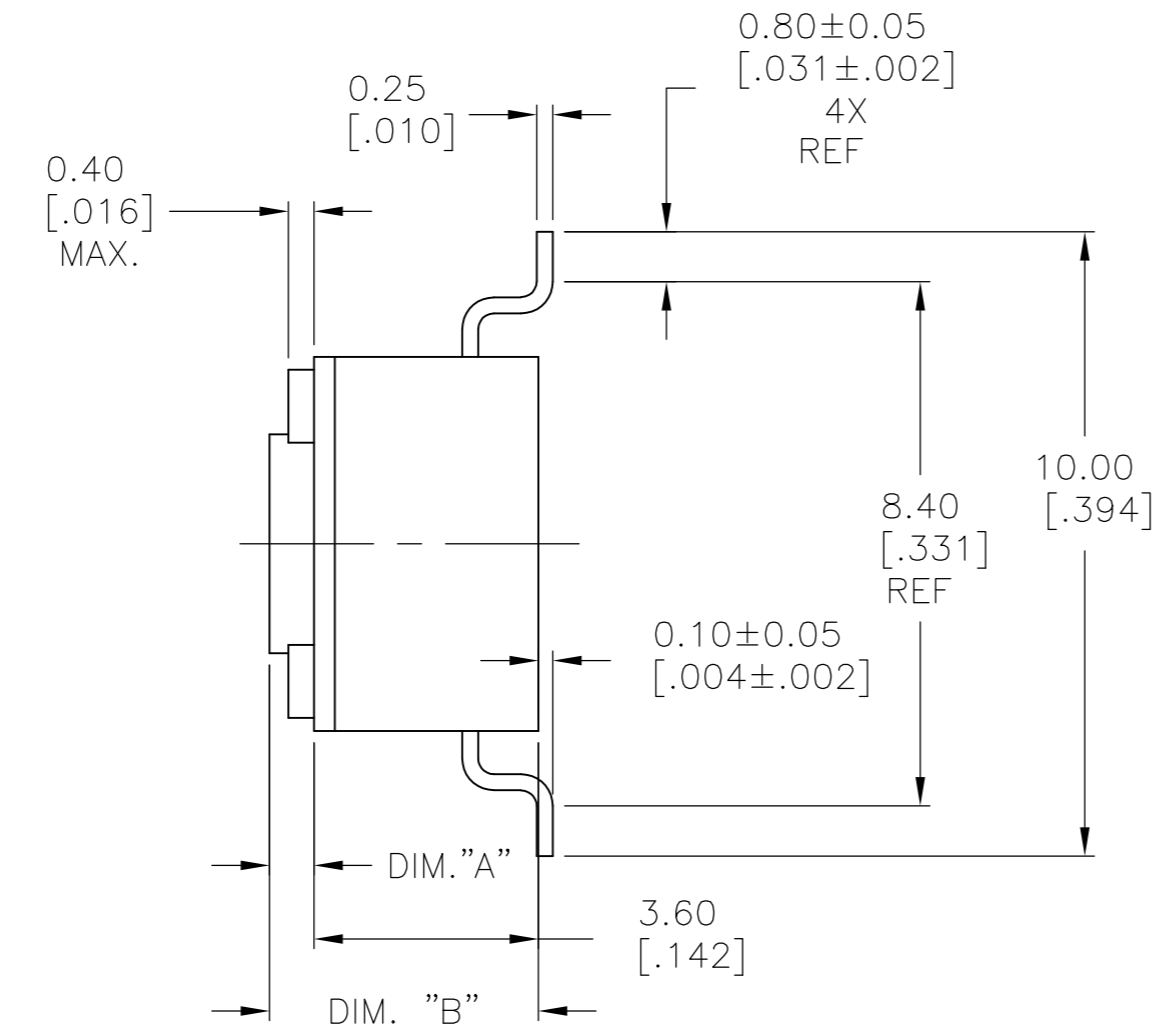
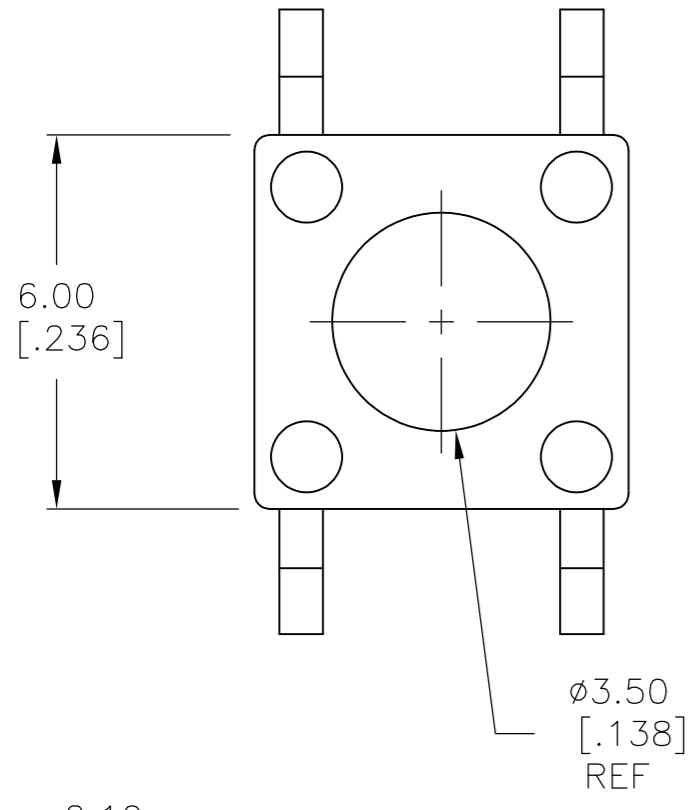

FSM2JSMA AS SHOWN

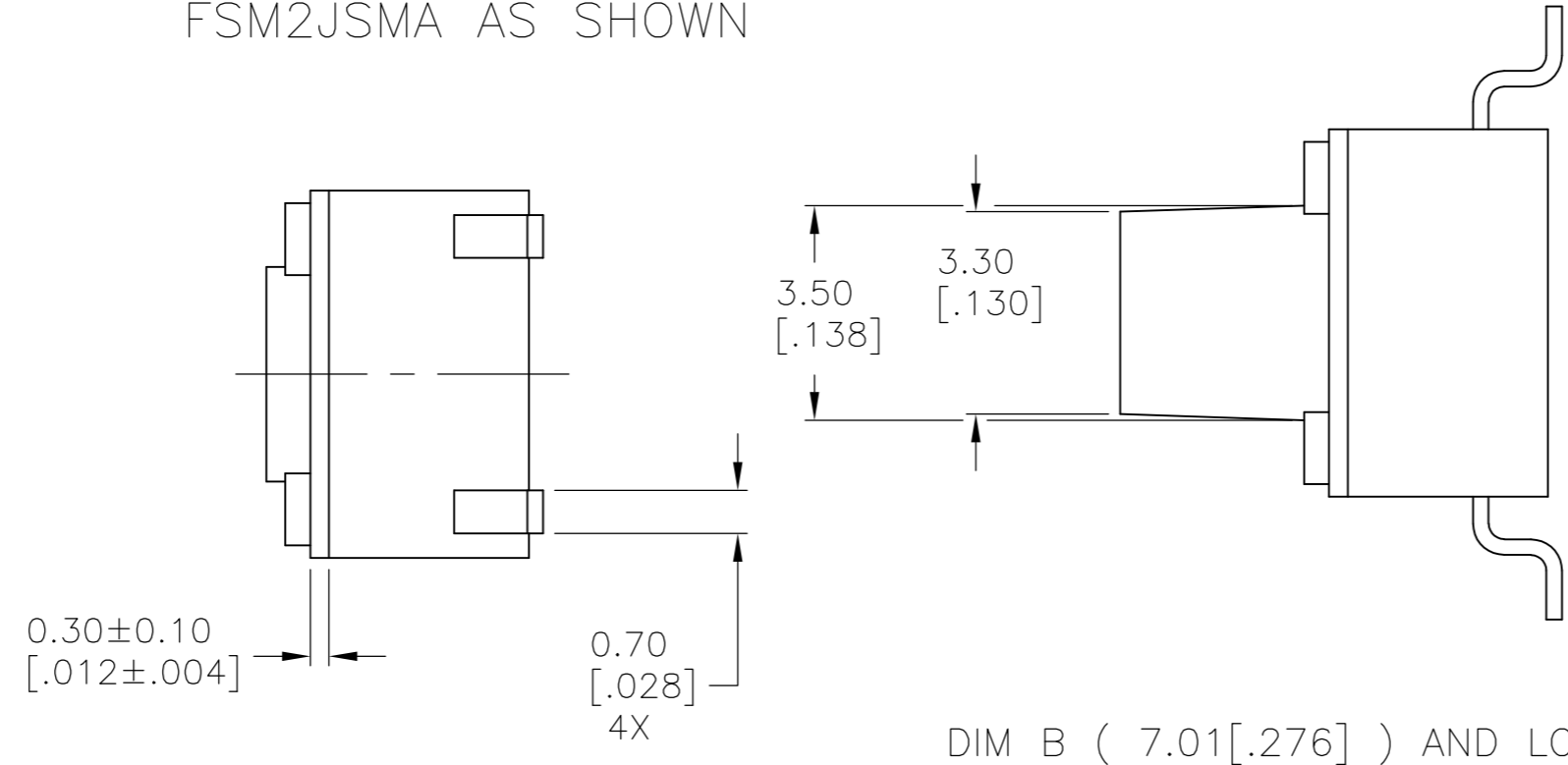

DIM B (7.01[.276]) AND LONGER MODELS

NOTES:

- 1 TAPE AND REEL PACKAGING PER EIA 481.
- 2 ALL MATERIALS AND FINISHES SHALL COMPLY WITH EU DIRECTIVE 2002/95/EC OF 27JAN2003 (ROHS)

()-INDICATES MOMENTARY POSITION		
CIRCUIT CHARACTERISTICS		
CONTACT POSITION	CIRCUIT DIAGRAM	
OFF	(ON)	
1 - 3 2 - 4		

THIS DRAWING IS A CONTROLLED DOCUMENT.		DWN M.BINNER 07NOV2007	TE Connectivity		
DIMENSIONS: mm [INCHES]		CHK M.SARVER 07NOV07			
TOLERANCES UNLESS OTHERWISE SPECIFIED:		APVD M.SARVER 07NOV07	NAME MICRO MINIATURE PUSHBUTTON SWITCH FSM JSM		
0 PLC ± - 1 PLC ± - 2 PLC ± 0.30[.012] 3 PLC ± - 4 PLC ± - ANGLES ± 1°		PRODUCT SPEC	SIZE	CAGE CODE	DRAWING NO
MATERIAL		APPLICATION SPEC	A2	00779	C=1977223
FINISH		WEIGHT	SCALE		SHEET
		0	8:1		1 of 2
CUSTOMER DRAWING			REV A5		

THIS DRAWING IS UNPUBLISHED. RELEASED FOR PUBLICATION 2-1437565-7, 2-1437565-7
 © COPYRIGHT 2-1437565-7 ALL RIGHTS RESERVED.

REVISIONS					
P	LTR	DESCRIPTION	DATE	DWN	APVD
-	-	SEE SHEET 1	-	-	-

Life Cycle	Actuator Color	Actuator Material	Actuation Force	PITCH	TAPE WIDTH	DIM B	DIM A	T&B P/N	P/N	
1,000,000	DEEP PINK	Nylon	260±50g			13.00±0.20[.512±.008]	9.40±0.10[.370±.004]	FSM14JSMAAS	2-1977223-9	
1,000,000	GREEN	Nylon	260±50g			13.00±0.20[.512±.008]	9.40±0.10[.370±.004]	FSM14JSMAS	2-1977223-8	
1,000,000	BLUE	Nylon	100±30g			13.00±0.20[.512±.008]	9.40±0.10[.370±.004]	FSM14JSMLS	2-1977223-7	
1,000,000	DEEP PINK	Nylon	260±50g	12 MM	24 MM	9.50±0.20[.374±.008]	5.89±0.10[.232±.004]	FSM8JSMAASTR	2-1977223-6	
OBSOLETE	DEEP PINK	Nylon	260±50g			9.50±0.20[.374±.008]	5.89±0.10[.232±.004]	FSM8JSMAAS	2-1977223-5	
1,000,000	GREEN	Nylon	160±50g	12 MM	24 MM	9.50±0.20[.374±.008]	5.89±0.10[.232±.004]	FSM8JSMAS	2-1977223-4	
OBSOLETE	GREEN	Nylon	160±50g			9.50±0.20[.374±.008]	5.89±0.10[.232±.004]	FSM8JSMAS	2-1977223-3	
1,000,000	BLUE	Nylon	100±30g	12 MM	24 MM	9.50±0.20[.374±.008]	5.89±0.10[.232±.004]	FSM8JSMLSTR	2-1977223-2	
OBSOLETE	BLUE	Nylon	100±30g			9.50±0.20[.374±.008]	5.89±0.10[.232±.004]	FSM8JSMLS	2-1977223-1	
1,000,000	DEEP PINK	Nylon	260±50g	12 MM	24 MM	7.01±0.20[.276±.008]	3.40±0.10[.134±.004]	FSM6JSMAASTR	2-1977223-0	
1,000,000	DEEP PINK	Nylon	260±50g			7.01±0.20[.276±.008]	3.40±0.10[.134±.004]	FSM6JSMAAS	1-1977223-9	
OBSOLETE	GREEN	Nylon	160±50g	12 MM	24 MM	7.01±0.20[.276±.008]	3.40±0.10[.134±.004]	FSM6JSMAS	1-1977223-8	
OBSOLETE	GREEN	Nylon	160±50g			7.01±0.20[.276±.008]	3.40±0.10[.134±.004]	FSM6JSMAS	1-1977223-7	
1,000,000	BLUE	Nylon	100±30g	12 MM	24 MM	7.01±0.20[.276±.008]	3.40±0.10[.134±.004]	FSM6JSMLSTR	1-1977223-6	
1,000,000	BLUE	Nylon	100±30g			7.01±0.20[.276±.008]	3.40±0.10[.134±.004]	FSM6JSMLS	1-1977223-5	
OBSOLETE	VIOLET	Nylon	70±30g	12 MM	16 MM	4.98±0.25[.196±.010]	1.40±0.10[.055±.004]	FSM4JSMXLSTR	1-1977223-4	
OBSOLETE	VIOLET	Nylon	70±30g			4.98±0.25[.196±.010]	1.40±0.10[.055±.004]	FSM4JSMXLS	1-1977223-3	
OBSOLETE	DEEP PINK	Nylon	260±50g	12 MM	16 MM	4.98±0.25[.196±.010]	1.40±0.10[.055±.004]	FSM4JSMAASTR	1-1977223-2	
OBSOLETE	DEEP PINK	Nylon	260±50g			4.98±0.25[.196±.010]	1.40±0.10[.055±.004]	FSM4JSMAAS	1-1977223-1	
1,000,000	GREEN	Nylon	160±50g	12 MM	16 MM	4.98±0.25[.196±.010]	1.40±0.10[.055±.004]	FSM4JSMAS	1977223-9	
1,000,000	GREEN	Nylon	160±50g			4.98±0.25[.196±.010]	1.40±0.10[.055±.004]	FSM4JSMAS	1977223-9	
SUPERCEDED BY 1571563-8	1,000,000	BLUE	Nylon	100±30g	12 MM	16 MM	4.98±0.25[.196±.010]	1.40±0.10[.055±.004]	FSM4JSMLSTR	1977223-8
SUPERCEDED BY 1571563-7	1,000,000	BLUE	Nylon	100±30g			4.98±0.25[.196±.010]	1.40±0.10[.055±.004]	FSM4JSMLS	1977223-7
1,000,000	DEEP PINK	Nylon	260±50g	12 MM	16 MM	4.29±0.20[.169±.008]	0.71±0.10[.028±.004]	FSM2JSMAASTR	1977223-6	
1,000,000	DEEP PINK	Nylon	260±50g			4.29±0.20[.169±.008]	0.71±0.10[.028±.004]	FSM2JSMAAS	1977223-5	
1,000,000	GREEN	Nylon	160±50g	12 MM	16 MM	4.29±0.20[.169±.008]	0.71±0.10[.028±.004]	FSM2JSMAS	1977223-4	
1,000,000	GREEN	Nylon	160±50g			4.29±0.20[.169±.008]	0.71±0.10[.028±.004]	FSM2JSMAS	1977223-3	
1,000,000	BLUE	Nylon	100±30g	12 MM	16 MM	4.29±0.20[.169±.008]	0.71±0.10[.028±.004]	FSM2JSMLSTR	1977223-2	
1,000,000	BLUE	Nylon	100±30g			4.29±0.20[.169±.008]	0.71±0.10[.028±.004]	FSM2JSMLS	1977223-1	

SUPERCEDED BY 1571563-8
 SUPERCEDED BY 1571563-7

THIS DRAWING IS A CONTROLLED DOCUMENT.		DWN M.BINNER 07NOV2007	 TE Connectivity	
DIMENSIONS: mm [INCHES]		CHK M.SARVER 07NOV07		
TOLERANCES UNLESS OTHERWISE SPECIFIED:		APVD M.SARVER 07NOV07	NAME MICRO MINIATURE PUSHBUTTON SWITCH FSM JSM	
0 PLC ± - 1 PLC ± - 2 PLC ± 0.30[.012] 3 PLC ± - 4 PLC ± - ANGLES ± 1°		PRODUCT SPEC -	SIZE A2	
MATERIAL -		FINISH -	APPLICATION SPEC -	CAGE CODE 00779
		WEIGHT -	DRAWING NO C=1977223	RESTRICTED TO -
CUSTOMER DRAWING			SCALE 8:1	SHEET 2 OF 2
			REV A5	