



Chipsmall Limited consists of a professional team with an average of over 10 year of expertise in the distribution of electronic components. Based in Hongkong, we have already established firm and mutual-benefit business relationships with customers from,Europe,America and south Asia,supplying obsolete and hard-to-find components to meet their specific needs.

With the principle of “Quality Parts,Customers Priority,Honest Operation,and Considerate Service”,our business mainly focus on the distribution of electronic components. Line cards we deal with include Microchip,ALPS,ROHM,Xilinx,Pulse,ON,Everlight and Freescale. Main products comprise IC,Modules,Potentiometer,IC Socket,Relay,Connector.Our parts cover such applications as commercial,industrial, and automotives areas.

We are looking forward to setting up business relationship with you and hope to provide you with the best service and solution. Let us make a better world for our industry!



## Contact us

Tel: +86-755-8981 8866 Fax: +86-755-8427 6832

Email & Skype: info@chipsmall.com Web: www.chipsmall.com

Address: A1208, Overseas Decoration Building, #122 Zhenhua RD., Futian, Shenzhen, China





Is Now Part of



**ON Semiconductor®**

To learn more about ON Semiconductor, please visit our website at  
[www.onsemi.com](http://www.onsemi.com)

Please note: As part of the Fairchild Semiconductor integration, some of the Fairchild orderable part numbers will need to change in order to meet ON Semiconductor's system requirements. Since the ON Semiconductor product management systems do not have the ability to manage part nomenclature that utilizes an underscore (\_), the underscore (\_) in the Fairchild part numbers will be changed to a dash (-). This document may contain device numbers with an underscore (\_). Please check the ON Semiconductor website to verify the updated device numbers. The most current and up-to-date ordering information can be found at [www.onsemi.com](http://www.onsemi.com). Please email any questions regarding the system integration to [Fairchild\\_questions@onsemi.com](mailto:Fairchild_questions@onsemi.com).

ON Semiconductor and the ON Semiconductor logo are trademarks of Semiconductor Components Industries, LLC dba ON Semiconductor or its subsidiaries in the United States and/or other countries. ON Semiconductor owns the rights to a number of patents, trademarks, copyrights, trade secrets, and other intellectual property. A listing of ON Semiconductor's product/patent coverage may be accessed at [www.onsemi.com/site/pdf/Patent-Marking.pdf](http://www.onsemi.com/site/pdf/Patent-Marking.pdf). ON Semiconductor reserves the right to make changes without further notice to any products herein. ON Semiconductor makes no warranty, representation or guarantee regarding the suitability of its products for any particular purpose, nor does ON Semiconductor assume any liability arising out of the application or use of any product or circuit, and specifically disclaims any and all liability, including without limitation special, consequential or incidental damages. Buyer is responsible for its products and applications using ON Semiconductor products, including compliance with all laws, regulations and safety requirements or standards, regardless of any support or applications information provided by ON Semiconductor. "Typical" parameters which may be provided in ON Semiconductor data sheets and/or specifications can and do vary in different applications and actual performance may vary over time. All operating parameters, including "Typicals" must be validated for each customer application by customer's technical experts. ON Semiconductor does not convey any license under its patent rights nor the rights of others. ON Semiconductor products are not designed, intended, or authorized for use as a critical component in life support systems or any FDA Class 3 medical devices or medical devices with a same or similar classification in a foreign jurisdiction or any devices intended for implantation in the human body. Should Buyer purchase or use ON Semiconductor products for any such unintended or unauthorized application, Buyer shall indemnify and hold ON Semiconductor and its officers, employees, subsidiaries, affiliates, and distributors harmless against all claims, costs, damages, and expenses, and reasonable attorney fees arising out of, directly or indirectly, any claim of personal injury or death associated with such unintended or unauthorized use, even if such claim alleges that ON Semiconductor was negligent regarding the design or manufacture of the part. ON Semiconductor is an Equal Opportunity/Affirmative Action Employer. This literature is subject to all applicable copyright laws and is not for resale in any manner.



# FSUSB11 — Low-Power, Full-Speed (12Mbps) Switch

## Features

- Space Saving MicroPak™ (1.6 x 2.1mm)
- USB 1.1 Signal Switching Compliant
- 3db Bandwidth: >350MHz
- Maximum 1.15Ω R<sub>ON</sub> at 4.5V V<sub>CC</sub> and 4Ω for 2.7V Supply
- 0.3Ω Maximum R<sub>ON</sub> Flatness for +5V Supply
- Broad V<sub>CC</sub> Operating Range: 1.65V to 5.5V
- Fast Turn-On and Turn-Off Time
- Break-Before-Make Enable Circuitry
- Over-Voltage Tolerant, TTL-Compatible Control Input

## Description

The FSUSB11 is a high-performance, dual Single-Pole Double-Throw (SPDT) switch designed for switching USB 1.1 signals. The device features ultra-low on resistance (R<sub>ON</sub>) of 1.15Ω maximum at 4.5V V<sub>CC</sub> and 4.3Ω at 2.7V supply. High bandwidth and ultra low (R<sub>ON</sub>) make this switch able to pass both USB low- and full-speed signal with minimum signal distortion. The device is fabricated with sub-micron CMOS technology to achieve fast switching speeds and designed for break-before-make operation. The select input is TTL-level compatible.

## Applications

- Cell Phones, PDAs, Digital Cameras, Notebook Computers

## Ordering Information

Part Number	Operating Temperature Range	Eco Status	Package	Packing Method
FSUSB11L10X	-40 to +85°C	RoHS	10-Lead, MicroPak™, JEDEC MO255, 1.6 X 2.1mm	Tape and Reel
FSUSB11MTCX	-40 to +85°C	RoHS	14-Lead Thin Shrink Small Outline Package (TSSOP), JEDEC MO-153, 4.4mm Wide	Tape and Reel

 For Fairchild's definition of Eco Status, please visit: [http://www.fairchildsemi.com/company/green/rohs\\_green.html](http://www.fairchildsemi.com/company/green/rohs_green.html).

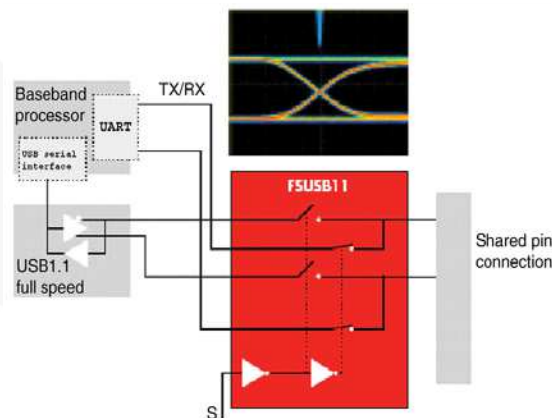

Figure 1. Block Diagram

MicroPak™ is a trademark of Fairchild Semiconductor Corporation.

## Pin Configuration

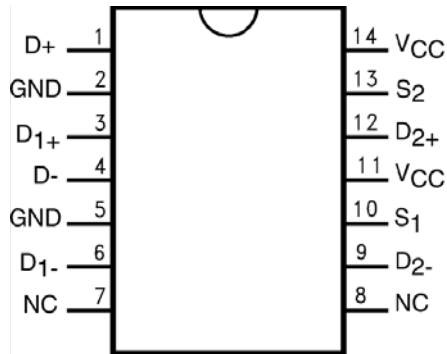

Figure 2. TSSOP Pin Assignment (Top View)

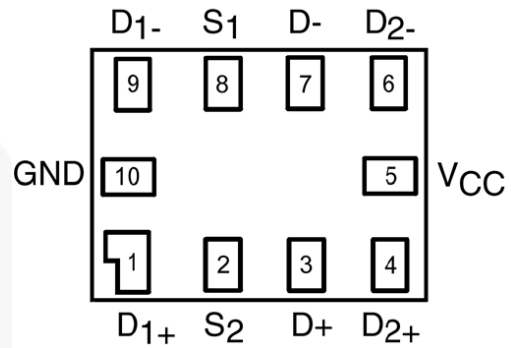

Figure 3. Micropak™ Pin Assignment (Top View)

## Analog Symbol

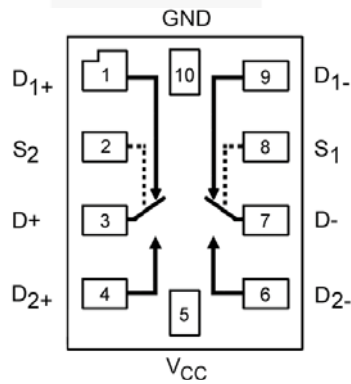

Figure 4. Analog Symbol

## Pin Descriptions

TSSOP Pin #	MicroPak™ Pin #	Pin Names	Description
1, 3, 4, 6, 9, 12	1, 3, 4, 6, 7, 9	D+, D <sub>1+</sub> , D-, D <sub>1-</sub> , D <sub>2-</sub> , D <sub>2+</sub>	Data Ports
2, 5	10	GND	Ground
7, 8		NC	No Connect
10, 13	2, 8	S <sub>1</sub> , S <sub>2</sub>	Control Input
11, 14	5	V <sub>CC</sub>	Supply Voltage

## Truth Table

Control Inputs	Function
Low Logic Level	D <sub>1</sub> Connected to D+/D-
High Logic Level	D <sub>2</sub> Connected to D+/D-

## Absolute Maximum Ratings

Stresses exceeding the absolute maximum ratings may damage the device. The device may not function or be operable above the recommended operating conditions and stressing the parts to these levels is not recommended. In addition, extended exposure to stresses above the recommended operating conditions may affect device reliability. The absolute maximum ratings are stress ratings only.

Symbol	Parameter	Min.	Max.	Unit
$V_{CC}$	Supply Voltage	-0.5	6.0	V
$V_S$	Switch Voltage	-0.5	$V_{CC} + 0.5$	V
$V_{IN}$	Input Voltage <sup>(1)</sup>	-0.5	6.0	V
$I_{IK}$	Input Diode Current	-50		mA
$I_{SW}$	Switch Current		200	mA
$I_{SWPEAK}$	Peak Switch Current (Pulsed at 1ms Duration, <10% Duty Cycle)		400	mA
$T_{STG}$	Storage Temperature Range	-65	+150	°C
$T_J$	Maximum Junction Temperature		+150	°C
$T_L$	Lead Temperature (Soldering, 10 Seconds)		+260	°C
ESD	Human Body Model, JESD22-A114		8	kV

**Note:**

1. The input and output negative voltage ratings may be exceeded if the input and output diode current ratings are observed.

## Recommended Operating Conditions

The Recommended Operating Conditions table defines the conditions for actual device operation. Recommended operating conditions are specified to ensure optimal performance to the datasheet specifications. Fairchild does not recommend exceeding them or designing to Absolute Maximum Ratings.

Symbol	Parameter	Min.	Max.	Unit
$V_{CC}$	Power Supply	1.65	5.50	V
$V_{IN}$	Control Input Voltage <sup>(2)</sup>	0	$V_{CC}$	$V_{CC}$
$V_{SW}$	Switch Input Voltage	0	$V_{CC}$	$V_{CC}$
$T_A$	Operating Temperature	-40	+85	°C

**Note:**

2. Unused inputs must be held HIGH or LOW. They may not float.

## DC Electrical Characteristics

Unless otherwise specified, typical values are at +25°C.

Symbol	Parameter	Conditions	V <sub>CC</sub> (V)	T <sub>A</sub> =+25°C			T <sub>A</sub> =-40 to +85°C		Units	
				Min.	Typ.	Max.	Min.	Max.		
V <sub>IH</sub>	Input Voltage High		2.7 to 3.6				2.0		V	
			4.5 to 5.5				4.0			
V <sub>IL</sub>	Input Voltage Low		2.7 to 3.6						V	
			4.5 to 5.5							
I <sub>IN</sub>	Control Input Leakage	V <sub>IN</sub> =0V to V <sub>CC</sub>	2.7 to 3.6						μA	
			4.5 to 5.5							
I <sub>NO(OFF)</sub> , I <sub>NO(OFF)</sub>	Off-Leakage Current of Port D <sub>1</sub> and D <sub>2</sub>	A=1V, 4.5V, B <sub>0</sub> or B <sub>1</sub> =1V, 4.5V	5.5	-50		50	-100	100	nA	
I <sub>A(ON)</sub>	On-Leakage Current of Port D	A=1V, 4.5V, B <sub>0</sub> or B <sub>1</sub> =1V, 4.5V or Floating	5.5	50		50	-100	100	nA	
R <sub>ON</sub>	Switch On Resistance <sup>(3)</sup>	Micropak	I <sub>OUT</sub> = 100mA, D <sub>1</sub> or D <sub>2</sub> =1.5V	2.7		2.60	4.00		4.30	Ω
			I <sub>OUT</sub> = 100mA, D <sub>1</sub> or D <sub>2</sub> =3.5V	4.5		0.95	1.15		1.30	
		TSSOP	I <sub>OUT</sub> = 100mA, D <sub>1</sub> or D <sub>2</sub> =1.5V	2.7		2.80			4.50	
			I <sub>OUT</sub> = 100mA, D <sub>1</sub> or D <sub>2</sub> =3.5V	4.5		1.50			3.00	
ΔR <sub>ON</sub>	On Resistance Matching Between Channel <sup>(4)</sup>	Micropak	I <sub>OUT</sub> = 100mA, D <sub>1</sub> or D <sub>2</sub> =3.5V	4.5		0.06	0.12		0.15	Ω
		TSSOP				0.07		0.30		
R <sub>FLAT(ON)</sub>	On Resistance Flatness <sup>(5)</sup>		I <sub>OUT</sub> =100mA, D <sub>1</sub> or D <sub>2</sub> =0V, 0.75V, 1.5V	2.7		1.4				Ω
			I <sub>OUT</sub> =100mA, B <sub>0</sub> or B <sub>1</sub> =0V, 1V, 2V	4.5		0.2	0.3		0.4	
I <sub>CC</sub>	Quiescent Supply Current	V <sub>IN</sub> =0V or V <sub>CC</sub> , I <sub>OUT</sub> =0	3.6		0.1	0.5		1.0	μA	
			5.5		0.1	0.5		1.0		

### Notes:

- On resistance is determined by the voltage drop between D and D<sub>n</sub> pins at the indicated current through the switch.
- ΔR<sub>ON</sub> = R<sub>ONmax</sub> - R<sub>ONmin</sub> measured at identical V<sub>CC</sub>, temperature, and voltage.
- Flatness is defined as the difference between the maximum and minimum value of on resistance over the specified range of conditions.

## AC Electrical Characteristics

Unless otherwise specified, typical values are at +25°C.

Symbol	Parameter	Conditions	V <sub>CC</sub> (V)	T <sub>A</sub> =+25°C			T <sub>A</sub> =-40 to +85°C		Units	Figure
				Min.	Typ.	Max.	Min.	Max.		
t <sub>ON</sub>	Turn-on Time S-to-Bus B	D <sub>1</sub> or D <sub>2</sub> =1.5V, R <sub>L</sub> =50Ω, C <sub>L</sub> =35pF	2.7 to 3.6			50		60	ns	Figure 5
		D <sub>1</sub> or D <sub>2</sub> =3.0V, R <sub>L</sub> =50Ω, C <sub>L</sub> =35pF	4.5 to 5.5			35		30		
t <sub>OFF</sub>	Turn-off Time S-to-Bus B	D <sub>1</sub> or D <sub>2</sub> =1.5V, R <sub>L</sub> =50Ω, C <sub>L</sub> =35pF	2.7 to 3.6			20		20	ns	Figure 5
		D <sub>1</sub> or D <sub>2</sub> =3.0V, R <sub>L</sub> =50Ω, C <sub>L</sub> =35pF	4.5 to 5.5			15				
t <sub>BBM</sub>	Break-Before-Make Time	D <sub>1</sub> or D <sub>2</sub> =1.5V, R <sub>L</sub> =50Ω, C <sub>L</sub> =35pF	2.7 to 3.6				1		ns	Figure 6
		D <sub>1</sub> or D <sub>2</sub> =3.0V, R <sub>L</sub> =50Ω, C <sub>L</sub> =35pF	4.5 to 5.5		20		1			
Q	Charge Injection	C <sub>L</sub> =1.0nF, V <sub>GEN</sub> =0V, R <sub>GEN</sub> =0Ω	2.7 to 3.6		20				pC	Figure 8
			4.5 to 5.5		10					
O <sub>IRR</sub>	Off Isolation	f=1MHz, R <sub>L</sub> =50Ω	2.7 to 3.6		-70				dB	Figure 7
			4.5 to 5.5		-70					
X <sub>TALK</sub>	Non-Adjacent Channel Crosstalk	f=1MHz, R <sub>L</sub> =50Ω	2.7 to 3.6		-75				dB	Figure 7
			4.5 to 5.5		-75					
BW	-3dB Bandwidth	R <sub>L</sub> =50Ω	2.7 to 3.6		350				MHz	Figure 10
			4.5 to 5.5		350					

## USB Related AC Electrical Characteristics

Unless otherwise specified, typical values are at 25°C.

Symbol	Parameter	Conditions	V <sub>CC</sub> (V)	T <sub>A</sub> =+25°C			Units	Figure
				Min.	Typ.	Max.		
t <sub>SK(O)</sub>	Skew	R <sub>S</sub> =39, C <sub>L</sub> =50pF, t <sub>R</sub> =t <sub>F</sub> =12ns at 12Mbps	2.7 to 3.6		0.15		ns	Figure 11
			4.5 to 5.5		0.15			
t <sub>SK(P)</sub>	Rising/Fall Time Mismatch	(Duty Cycle=50%)	2.7 to 3.6		30		ps	Figure 12
			4.5 to 5.5		20			
T <sub>J</sub>	Total Jitter	R <sub>S</sub> =39, C <sub>L</sub> =50pF, t <sub>R</sub> =t <sub>F</sub> =12ns at 12Mbps (PRBS=2 <sup>15</sup> -1)	2.7 to 3.6		1.7		ps	Figure 12
			4.5 to 5.5		1.6			

## Capacitance

Symbol	Parameter	Conditions	V <sub>CC</sub> (V)	T <sub>A</sub> =+25°C			Units	Figure
				Min.	Typ.	Max.		
C <sub>IN</sub>	Control Pin Input Capacitance	f=1MHz	0.0		3.5		pF	Figure 9
C <sub>OFF</sub>	D <sub>n</sub> Port Off Capacitance	f=1MHz	4.5		12.0		pF	Figure 9
C <sub>ON</sub>	D Port On Capacitance	f=1MHz	4.5		40.0		pF	Figure 9

### AC Loadings and Waveforms

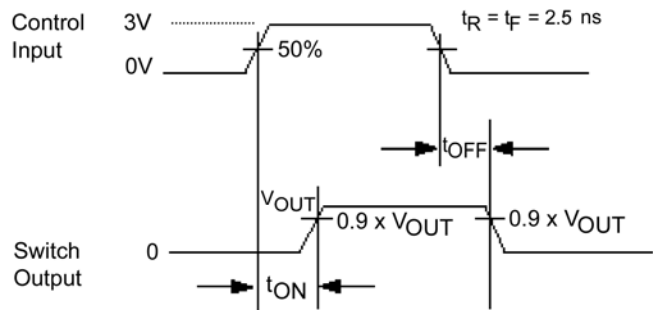
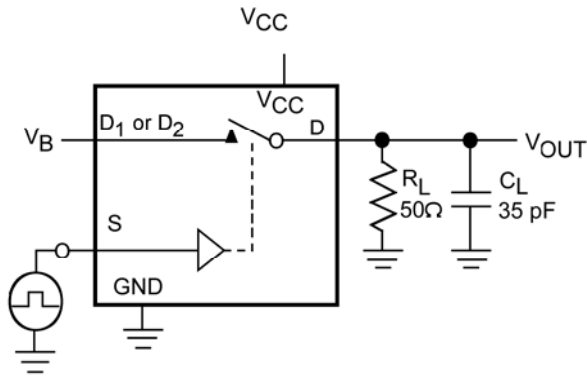

**Note:**

6.  $C_L$  includes fixture and stray capacitance.

**Note:**

7. Logic input waveforms inverted for switches that have the opposite logic sense.

**Figure 5. Turn On/ Turn Off Timing**

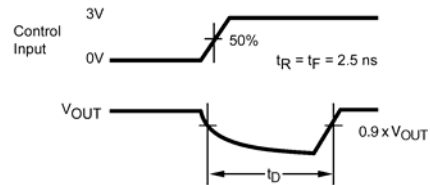
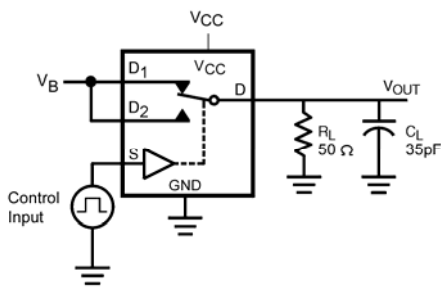

**Note:**

8.  $C_L$  includes fixture and stray capacitance.

**Figure 6. Break-Before-Make Timing**

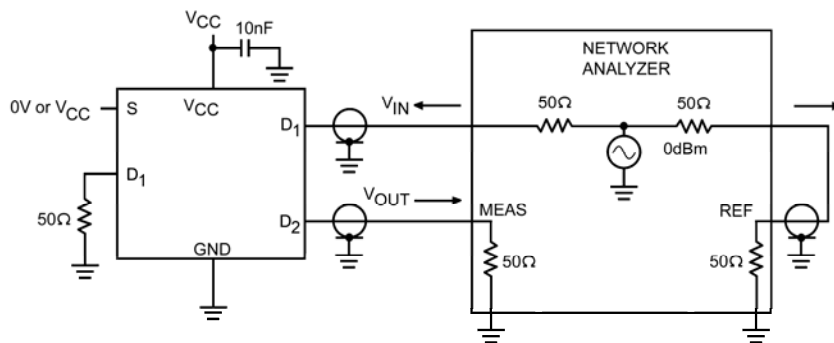

$$\text{OFF-ISOLATION} = 20 \log \frac{V_{OUT}}{V_{IN}}$$

$$\text{ON-LOSS} = 20 \log \frac{V_{OUT}}{V_{IN}}$$

$$\text{CROSSTALK} = 20 \log \frac{V_{OUT}}{V_{IN}}$$

**Figure 7. Off Isolation and Crosstalk**



**AC Loadings and Waveforms (Continued)**

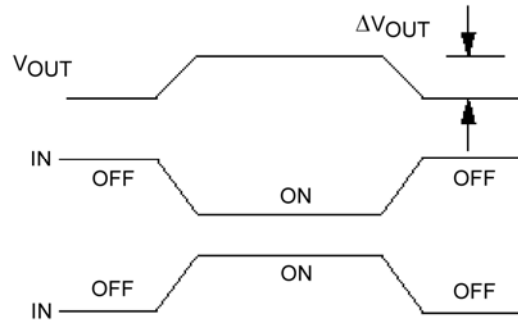
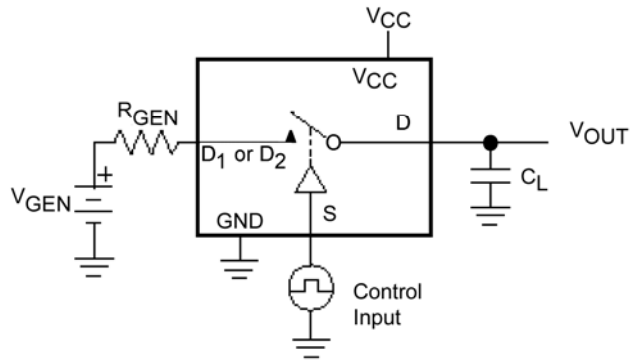

**Note:**  
9.  $Q = (\Delta V_{OUT}) (C_L)$ .

**Figure 8. Charge Injection**

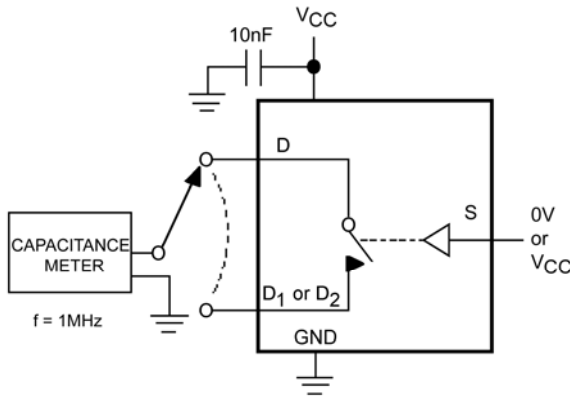

**Figure 9. On/Off Capacitance Measurement Setup**

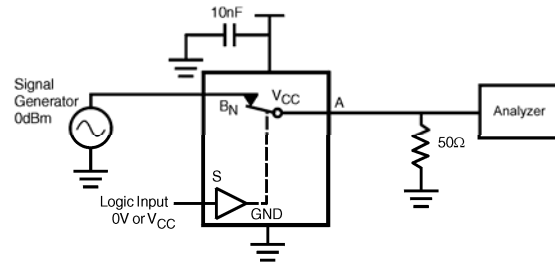

**Figure 10. Bandwidth**

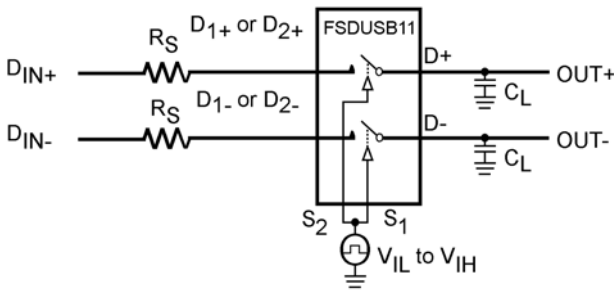

**Figure 11. Skew Test**

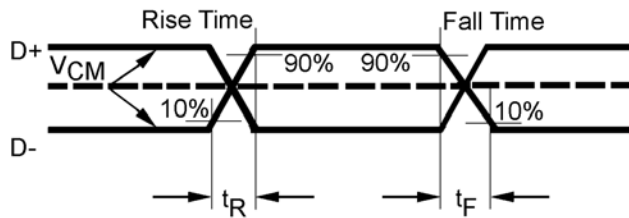
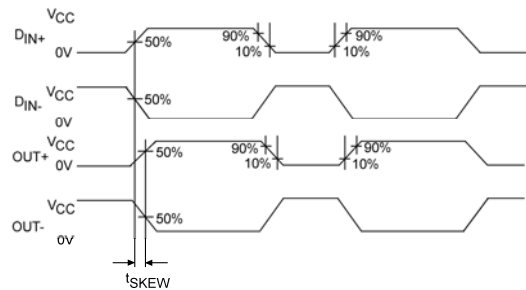

$$1.3V < V_{CM} < 2V$$

$$t_M = \frac{|t_R - t_F|}{\min(t_R, t_F)}$$

**Figure 12. Rise/Fall Time Mismatch Test**

## Physical Dimensions

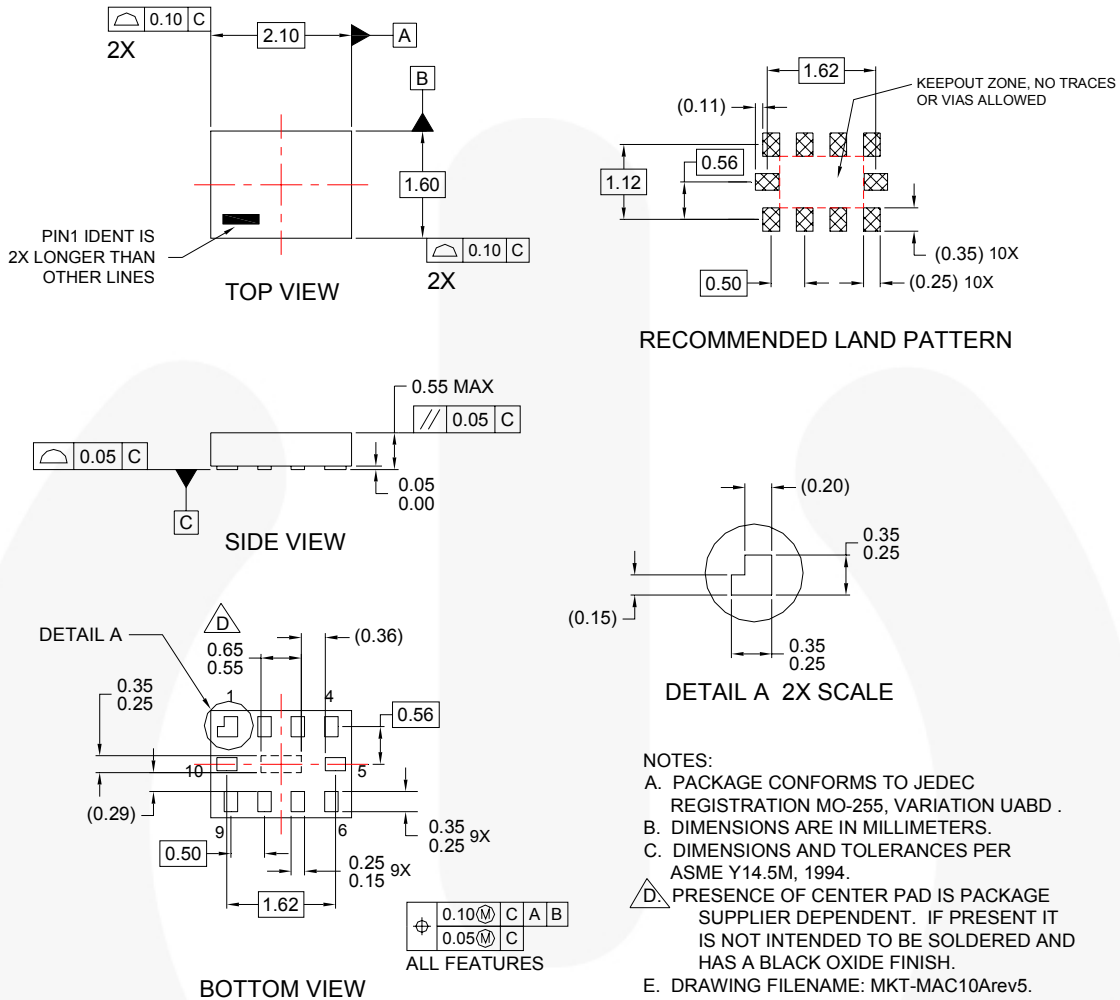

**Figure 13. 10-Lead, MicroPak™, JEDEC MO255, 1.6 X 2.1mm**

Package drawings are provided as a service to customers considering Fairchild components. Drawings may change in any manner without notice. Please note the revision and/or date on the drawing and contact a Fairchild Semiconductor representative to verify or obtain the most recent revision. Package specifications do not expand the terms of Fairchild's worldwide terms and conditions, specifically the warranty therein, which covers Fairchild products.

Always visit Fairchild Semiconductor's online packaging area for the most recent package drawings:  
<http://www.fairchildsemi.com/packaging/>.

## Tape and Reel Specification

Please visit Fairchild Semiconductor's online packaging area for the most recent tape and reel specifications:  
[http://www.fairchildsemi.com/products/logic/pdf/micropak\\_tr.pdf](http://www.fairchildsemi.com/products/logic/pdf/micropak_tr.pdf).

Package Designator	Tape Section	Cavity Number	Cavity Status	Cover Type Status
L10X	Leader (Start End)	125 (Typical)	Empty	Sealed
	Carrier	5000	Filled	Sealed
	Trailer (Hub End)	75 (Typical)	Empty	Sealed

## Physical Dimensions

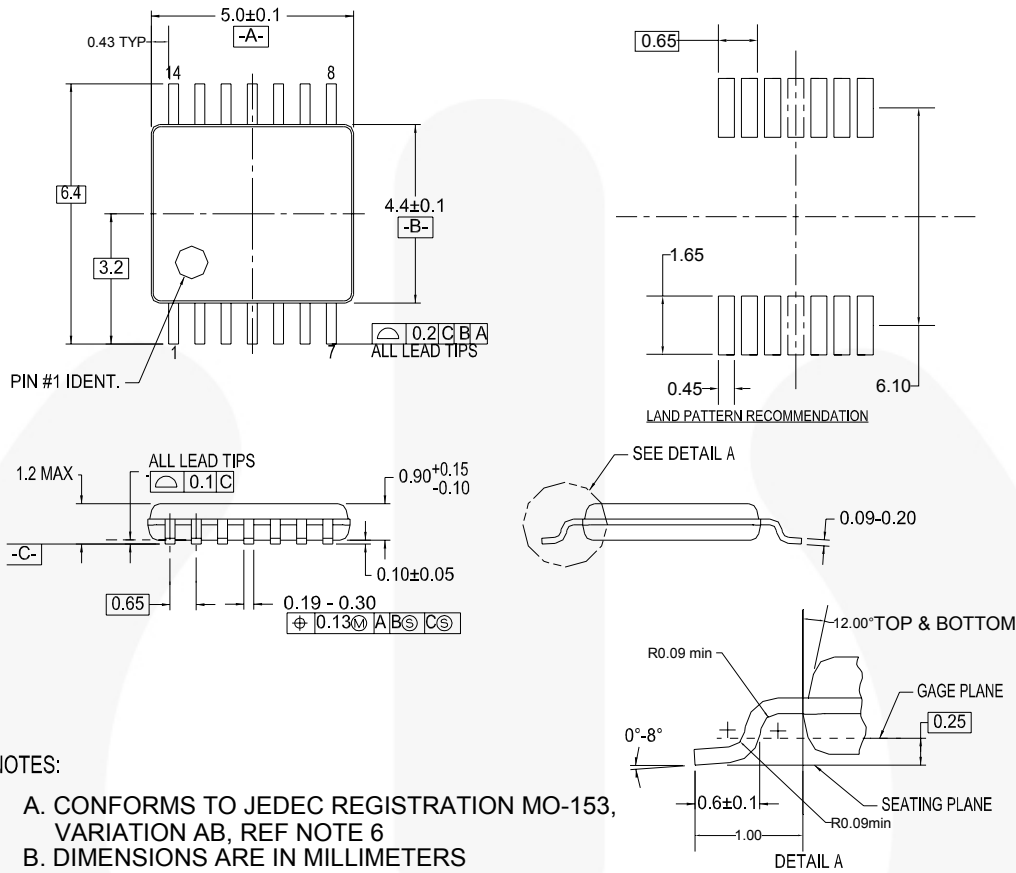

**Figure 14. 14-Lead Thin Shrink Small Outline Package (TSSOP), JEDEC MO-153, 4.4mm Wide**

Package drawings are provided as a service to customers considering Fairchild components. Drawings may change in any manner without notice. Please note the revision and/or date on the drawing and contact a Fairchild Semiconductor representative to verify or obtain the most recent revision. Package specifications do not expand the terms of Fairchild's worldwide terms and conditions, specifically the warranty therein, which covers Fairchild products.

Always visit Fairchild Semiconductor's online packaging area for the most recent package drawings:  
<http://www.fairchildsemi.com/packaging/>



**TRADEMARKS**

The following includes registered and unregistered trademarks and service marks, owned by Fairchild Semiconductor and/or its global subsidiaries, and is not intended to be an exhaustive list of all such trademarks.

- |                          |                        |                                       |   |
|--------------------------|------------------------|---------------------------------------|---|
| AccuPower™               | FlashWriter®*          | Power-SPM™                            | <p><b>SYSTEM GENERAL</b><br/>The Power Franchise®</p> <p><b>the power franchise</b></p> <p>TinyBoost™</p> <p>TinyBuck™</p> <p>TinyCalc™</p> <p>TinyLogic®</p> <p>TINYOPTO™</p> <p>TinyPower™</p> <p>TinyPWM™</p> <p>TinyWire™</p> <p>TriFault Detect™</p> <p>TRUECURRENT™*</p> <p>µSerDes™</p> <p>UHC®</p> <p>Ultra FRFET™</p> <p>UniFET™</p> <p>VCX™</p> <p>VisualMax™</p> <p>XST™</p> |
| Auto-SPM™                | FPS™                   | PowerTrench®                          |   |
| Build it Now™            | F-PFS™                 | PowerXS™                              |   |
| CorePLUS™                | FRFET®                 | Programmable Active Droop™            |   |
| CorePOWER™               | Global Power Resource™ | QFET®                                 |   |
| CROSSVOLT™               | Green FPS™             | QS™                                   |   |
| CTL™                     | Green FPS™ e-Series™   | Quiet Series™                         |   |
| Current Transfer Logic™  | Gmax™                  | RapidConfigure™                       |   |
| EcoSPARK®                | GTO™                   | ™                                     |   |
| EfficientMax™            | IntelliMAX™            | Saving our world, 1mW/W/kW at a time™ |   |
| EZSWITCH™*               | ISOPLANAR™             | SignalWise™                           |   |
| ™*                       | MegaBuck™              | SmartMax™                             |   |
| DEUXPEED™                | MICROCOUPLER™          | SMART START™                          |   |
| ™                        | MicroFET™              | SPM®                                  |   |
| Fairchild®               | MicroPak™              | STEALTH™                              |   |
| Fairchild Semiconductor® | MillerDrive™           | SuperFET™                             |   |
| FACT Quiet Series™       | MotionMax™             | SuperSOT™.3                           |   |
| FACT®                    | Motion-SPM™            | SuperSOT™.6                           |   |
| FAST®                    | OPTOLOGIC®             | SuperSOT™.8                           |   |
| FastvCore™               | OPTOPLANAR®            | SupreMOS™                             |   |
| FETBench™                | ™                      | SyncFET™                              |   |
|                          | PDP SPM™               | Sync-Lock™                            |   |

\* Trademarks of System General Corporation, used under license by Fairchild Semiconductor.

**DISCLAIMER**

FAIRCHILD SEMICONDUCTOR RESERVES THE RIGHT TO MAKE CHANGES WITHOUT FURTHER NOTICE TO ANY PRODUCTS HEREIN TO IMPROVE RELIABILITY, FUNCTION, OR DESIGN. FAIRCHILD DOES NOT ASSUME ANY LIABILITY ARISING OUT OF THE APPLICATION OR USE OF ANY PRODUCT OR CIRCUIT DESCRIBED HEREIN; NEITHER DOES IT CONVEY ANY LICENSE UNDER ITS PATENT RIGHTS, NOR THE RIGHTS OF OTHERS. THESE SPECIFICATIONS DO NOT EXPAND THE TERMS OF FAIRCHILD'S WORLDWIDE TERMS AND CONDITIONS, SPECIFICALLY THE WARRANTY THEREIN, WHICH COVERS THESE PRODUCTS.

**LIFE SUPPORT POLICY**

FAIRCHILD'S PRODUCTS ARE NOT AUTHORIZED FOR USE AS CRITICAL COMPONENTS IN LIFE SUPPORT DEVICES OR SYSTEMS WITHOUT THE EXPRESS WRITTEN APPROVAL OF FAIRCHILD SEMICONDUCTOR CORPORATION.

As used herein:

1. Life support devices or systems are devices or systems which, (a) are intended for surgical implant into the body or (b) support or sustain life, and (c) whose failure to perform when properly used in accordance with instructions for use provided in the labeling, can be reasonably expected to result in a significant injury of the user.
2. A critical component in any component of a life support, device, or system whose failure to perform can be reasonably expected to cause the failure of the life support device or system, or to affect its safety or effectiveness.

**ANTI-COUNTERFEITING POLICY**

Fairchild Semiconductor Corporation's Anti-Counterfeiting Policy. Fairchild's Anti-Counterfeiting Policy is also stated on our external website, [www.fairchildsemi.com](http://www.fairchildsemi.com), under Sales Support.

Counterfeiting of semiconductor parts is a growing problem in the industry. All manufacturers of semiconductor products are experiencing counterfeiting of their parts. Customers who inadvertently purchase counterfeit parts experience many problems such as loss of brand reputation, substandard performance, failed applications, and increased cost of production and manufacturing delays. Fairchild is taking strong measures to protect ourselves and our customers from the proliferation of counterfeit parts. Fairchild strongly encourages customers to purchase Fairchild parts either directly from Fairchild or from Authorized Fairchild Distributors who are listed by country on our web page cited above. Products customers buy either from Fairchild directly or from Authorized Fairchild Distributors are genuine parts, have full traceability, meet Fairchild's quality standards for handling and storage and provide access to Fairchild's full range of up-to-date technical and product information. Fairchild and our Authorized Distributors will stand behind all warranties and will appropriately address any warranty issues that may arise. Fairchild will not provide any warranty coverage or other assistance for parts bought from Unauthorized Sources. Fairchild is committed to combat this global problem and encourage our customers to do their part in stopping this practice by buying direct or from authorized distributors.

**PRODUCT STATUS DEFINITIONS**

**Definition of Terms**

Datasheet Identification	Product Status	Definition
Advance Information	Formative / In Design	Datasheet contains the design specifications for product development. Specifications may change in any manner without notice.
Preliminary	First Production	Datasheet contains preliminary data; supplementary data will be published at a later date. Fairchild Semiconductor reserves the right to make changes at any time without notice to improve design.
No Identification Needed	Full Production	Datasheet contains final specifications. Fairchild Semiconductor reserves the right to make changes at any time without notice to improve the design.
Obsolete	Not In Production	Datasheet contains specifications on a product that is discontinued by Fairchild Semiconductor. The datasheet is for reference information only.

Rev. 143

ON Semiconductor and  are trademarks of Semiconductor Components Industries, LLC dba ON Semiconductor or its subsidiaries in the United States and/or other countries. ON Semiconductor owns the rights to a number of patents, trademarks, copyrights, trade secrets, and other intellectual property. A listing of ON Semiconductor's product/patent coverage may be accessed at [www.onsemi.com/site/pdf/Patent-Marking.pdf](http://www.onsemi.com/site/pdf/Patent-Marking.pdf). ON Semiconductor reserves the right to make changes without further notice to any products herein. ON Semiconductor makes no warranty, representation or guarantee regarding the suitability of its products for any particular purpose, nor does ON Semiconductor assume any liability arising out of the application or use of any product or circuit, and specifically disclaims any and all liability, including without limitation special, consequential or incidental damages. Buyer is responsible for its products and applications using ON Semiconductor products, including compliance with all laws, regulations and safety requirements or standards, regardless of any support or applications information provided by ON Semiconductor. "Typical" parameters which may be provided in ON Semiconductor data sheets and/or specifications can and do vary in different applications and actual performance may vary over time. All operating parameters, including "Typicals" must be validated for each customer application by customer's technical experts. ON Semiconductor does not convey any license under its patent rights nor the rights of others. ON Semiconductor products are not designed, intended, or authorized for use as a critical component in life support systems or any FDA Class 3 medical devices or medical devices with a same or similar classification in a foreign jurisdiction or any devices intended for implantation in the human body. Should Buyer purchase or use ON Semiconductor products for any such unintended or unauthorized application, Buyer shall indemnify and hold ON Semiconductor and its officers, employees, subsidiaries, affiliates, and distributors harmless against all claims, costs, damages, and expenses, and reasonable attorney fees arising out of, directly or indirectly, any claim of personal injury or death associated with such unintended or unauthorized use, even if such claim alleges that ON Semiconductor was negligent regarding the design or manufacture of the part. ON Semiconductor is an Equal Opportunity/Affirmative Action Employer. This literature is subject to all applicable copyright laws and is not for resale in any manner.

## PUBLICATION ORDERING INFORMATION

### LITERATURE FULFILLMENT:

Literature Distribution Center for ON Semiconductor  
19521 E. 32nd Pkwy, Aurora, Colorado 80011 USA  
**Phone:** 303-675-2175 or 800-344-3860 Toll Free USA/Canada  
**Fax:** 303-675-2176 or 800-344-3867 Toll Free USA/Canada  
**Email:** [orderlit@onsemi.com](mailto:orderlit@onsemi.com)

**N. American Technical Support:** 800-282-9855 Toll Free  
USA/Canada  
**Europe, Middle East and Africa Technical Support:**  
Phone: 421 33 790 2910  
**Japan Customer Focus Center**  
Phone: 81-3-5817-1050

**ON Semiconductor Website:** [www.onsemi.com](http://www.onsemi.com)  
**Order Literature:** <http://www.onsemi.com/orderlit>  
For additional information, please contact your local  
Sales Representative