



Chipsmall Limited consists of a professional team with an average of over 10 year of expertise in the distribution of electronic components. Based in Hongkong, we have already established firm and mutual-benefit business relationships with customers from,Europe,America and south Asia,supplying obsolete and hard-to-find components to meet their specific needs.

With the principle of “Quality Parts,Customers Priority,Honest Operation,and Considerate Service”,our business mainly focus on the distribution of electronic components. Line cards we deal with include Microchip,ALPS,ROHM,Xilinx,Pulse,ON,Everlight and Freescale. Main products comprise IC,Modules,Potentiometer,IC Socket,Relay,Connector.Our parts cover such applications as commercial,industrial, and automotives areas.

We are looking forward to setting up business relationship with you and hope to provide you with the best service and solution. Let us make a better world for our industry!



Contact us

Tel: +86-755-8981 8866 Fax: +86-755-8427 6832

Email & Skype: info@chipsmall.com Web: www.chipsmall.com

Address: A1208, Overseas Decoration Building, #122 Zhenhua RD., Futian, Shenzhen, China



FSUSB242

FSUSB242 Type-C USB Port Protection Switch

Features

- Fully USB Data Port Protection
- V_{DD} 0 V– 5.5 V (12 V DC tolerant)
- -18 V to +20 V DC Tolerance on HSD± Port
- ±25 V IEC 64000-4-5 Surge Protection w/o External TVS
- V_{DD} Operating Range, 2.7 V–5.5 V
- HSD RON: 5 Ω Typical
- C_{ON} = 5 pF Typical
- Wide -3 dB Bandwidth: > 720 MHz
- Low Power Operation: I_{CC} < 10 μ A (Typical)
- Over Voltage Protection: 3.6 V & 4.5 V

Typical Applications

- Smartphones
- Tablets
- Laptops

Safety Mechanisms Highlight

- 3.6 V & 4.5 V OVP Trip Point
- ±25 V Surge Protection without Need for External TVS

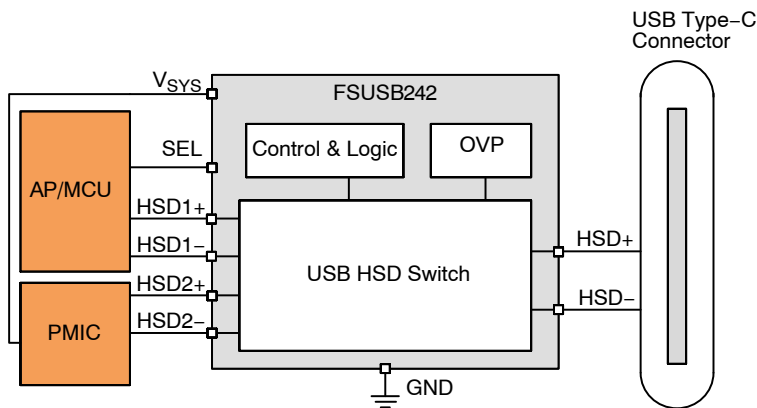

Figure 1. Application Schematic



ON Semiconductor®

www.onsemi.com



**WLCSP9 1.20 x 1.20
CASE 567UL**

MARKING DIAGRAM

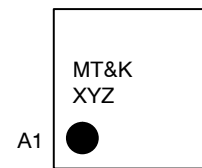

MT = Specific Device Code
 &K = 2 Digit Lot Run Code
 X = Year
 Y = 2 Week Data Code
 Z = Plant Code

PIN CONNECTION

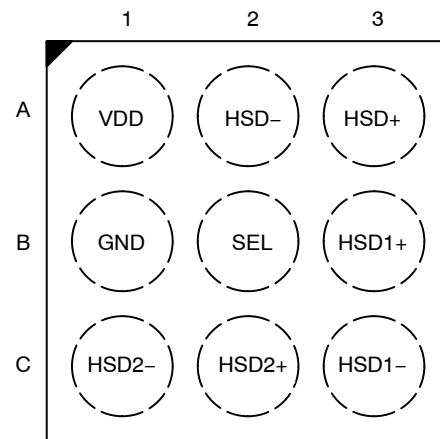

TOP Through View

ORDERING INFORMATION

See detailed ordering and shipping information on page 10 of this data sheet.

FSUSB242

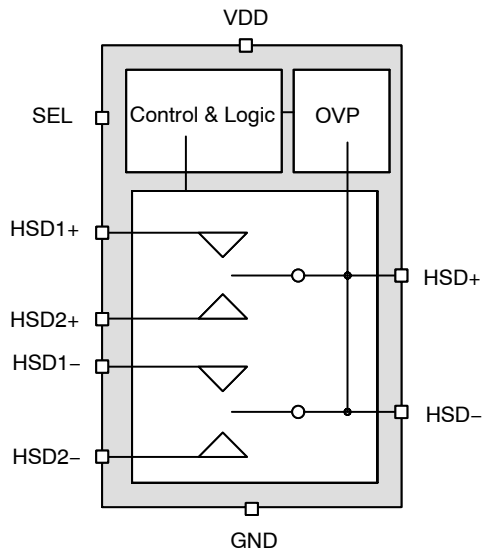

Figure 2. Simplified Block Diagram

Table 1. PIN FUNCTION DESCRIPTION

CSP Bump	Name	Type	Description
A1	VDD	Power	Supply Power
B1	GND	Ground	Ground
A3	HSD+	Data	Common High Speed Data Bus
A2	HSD-	Data	Common High Speed Data Bus
B3	HSD1+	Data	Multiplexed High Speed Data Port 1
C3	HSD1-	Data	Multiplexed High Speed Data Port 1
C2	HSD2+	Data	Multiplexed High Speed Data Port 2
C1	HSD2-	Data	Multiplexed High Speed Data Port 2
B2	SEL	I/O	Tri-Input HSD Switch Select & /OE

Table 2. SWITCH TRUTH TABLE CONFIGURATION

VDD	SEL	Switch Configuration
UVLO	X	Switch off High impedance
Valid	0	HSD+ = HSD1+, HSD- = HSD1-
Valid	1	HSD+ = HSD2+, HSD- = HSD2-
Valid	Float/High-Z	Switch Disable High impedance

APPLICATION INFORMATION

Over Voltage Protection

Over voltage protection turns the switch off if the inputs HSD+/HSD- rise above the over voltage trip threshold.

Under Voltage Lockout

The under-voltage lockout on V_{DD} pin turns the switch off if the V_{DD} voltage drops below the lockout threshold. With the SELpin active, the input voltage rising above the UVLO threshold releases the lockout and enables the switch.

Tri-State Input Control Pin (SEL)

The SEL pin can be tri-stated to disable the switch to save power, there are a few ways to achieve this. If the SEL pin is controlled by GPIO in the system, if the GPIO pin has a High-Z state where the impedance of the High-Z state is

larger than 2 MΩ the switch will recognize the High-Z state and disable the switch. If the system does not have GPIO that supports High-Z state, the user can utilize 2 MOSFETs or a Logic Device to achieve the same result.

For GPIO

The SEL pin function below:

- If the input is pulled up with less than 50 kΩ it will be considered as Logic High
- If the input is pulled down with less than 50 kΩ it will be consider as Logic Low
- If the input is pulled up or down with more 4 MΩ it will be consider as float/High-Z

System Timing Diagram

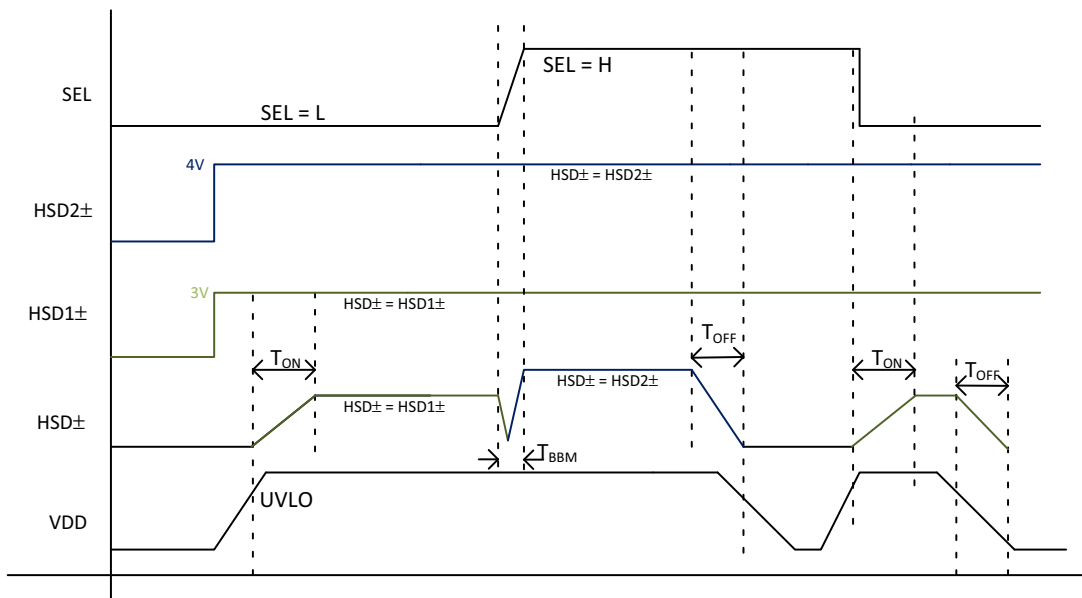

Figure 3. System Timing Plot

FSUSB242

USB High Speed Eye Diagram

$V_{DD} = 5.5\text{ V}$ HSD to HSD1 Path

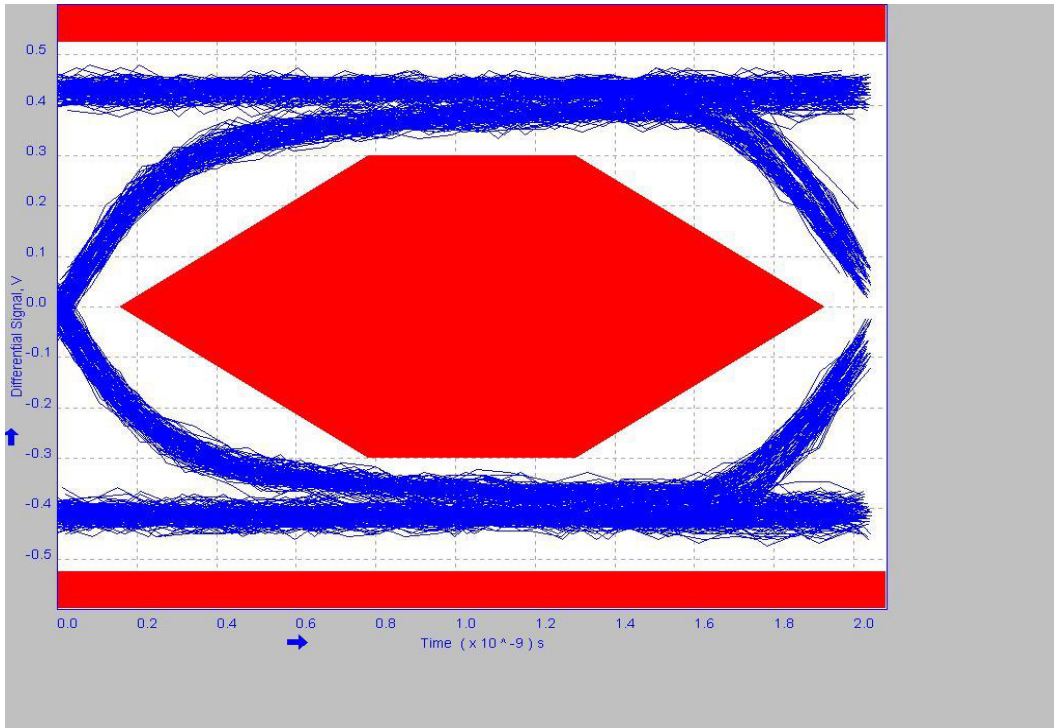

Figure 4. HS USB Eye @ $V_{DD} = 5\text{ V}$

$V_{DD} = 2.7\text{ V}$ HSD to HSD2 Path

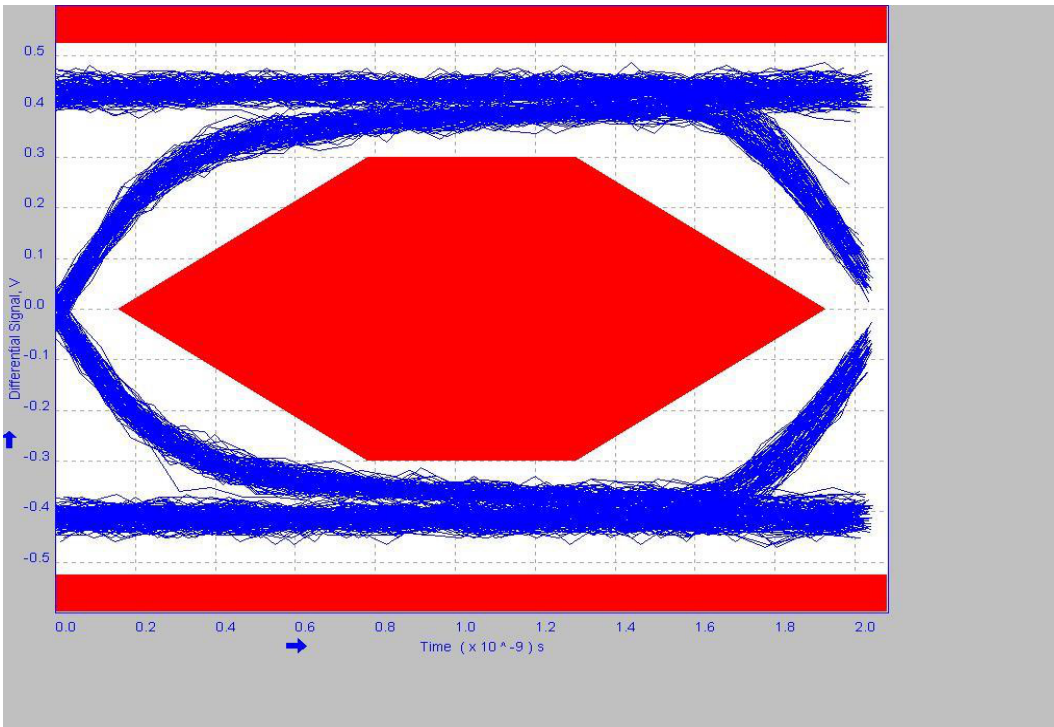

Figure 5. HS USB Eye @ $V_{DD} = 2.7\text{ V}$

FSUSB242

Table 3. ABSOLUTE MAXIMUM RATINGS

Symbol	Parameter		Min	Max	Unit	
V _{DD}	Supply Voltage from V _{DD}		-0.5	12.0	V	
V _{SW}	DC Input voltage tolerance for HSD±, to GND		-18	20	V	
	DC Input voltage tolerance for HSD1±, HSD2± to GND		-1.2	6	V	
V _{CONTROL}	DC Input Voltage (SEL)		-0.5	6	V	
I _{SW}	DC HSD Switch Current			100	mA	
I _{IK}	DC Input Diode Current		-50		mA	
T _{STORAGE}	Storage Temperature Range		-65	+150	°C	
T _J	Maximum Junction Temperature			+150	°C	
T _L	Lead Temperature (Soldering, 10 seconds)			+260	°C	
ESD	IEC 61000-4-2 System ESD	Connector Pins (HSD±)	Air Gap	15		kV
			Contact	8		
	Human Body Model, JEDEC JESD22-A114	Power to GND		2		kV
		Internal Pin to GND (HSD1±, HSD2±)		2		
		External Pin to GND (HSD±)		14		
	Charged Device Model, JEDEC LESD22-C101	All Pins		1		
		IEC 61000-4-5 Surge Protection	HSD±, to GND	±25		V
	V _{DD} to GND		+12		V	

Stresses exceeding those listed in the Maximum Ratings table may damage the device. If any of these limits are exceeded, device functionality should not be assumed, damage may occur and reliability may be affected.

Table 4. RECOMMENDED OPERATING CONDITIONS

Symbol	Parameter	Min	Typ	Max	Unit
V _{DD}	Supply Voltage	2.7	4.2	5.5	V
V _{SW1}	HSD1 Switch I/O Signal Swing Voltage (Note 1)	-0.5		3.6	V
V _{SW2}	HSD2 Switch I/O Signal Swing Voltage (Note 1)	-0.5		4.5	V
I _{CCSW}	Maximum HSD Switch Continuous Current			75	mA
V _{CNTRL}	Control Input Voltage (SEL)	-0.5		V _{DD}	V
T _A	Operating Temperature	-40		+85	°C

Functional operation above the stresses listed in the Recommended Operating Ranges is not implied. Extended exposure to stresses beyond the Recommended Operating Ranges limits may affect device reliability.

- The switch swing voltage is based on the OVP trip level, and when OVP triggers the switch will be disabled to protect the host and no longer in the standard operating condition, once over voltage is removed the device will automatically recover back to normal condition.

Table 5. DC ELECTRICAL CHARACTERISTICS

(Unless otherwise specified: Recommended T_A and T_J temperature ranges. All typical values are at T_A = 25°C and V_{DD} = 4.2 V unless otherwise specified.)

Symbol	Characteristic	V _{DD} (V)	Conditions	T _A = -40 to +85°C T _J = -40 to +125°C			Unit
				Min	Typ	Max	

BASIC OPERATION DEVICE

I _{CC}	Quiescent Supply Current	2.7 to 5.5	WLCSPP: /OE = H & L, I _{OUT} = 0		10		μA
I _{OFF}	Power-Off Leakage Current	0	V _{SWHSD1} = 0 V to 3.6 V, V _{SWHSD2} = 0 V to 4.5 V	-3		3	μA
I _{IN}	Control Input Leakage	2.7 to 5.5	V _{CNTRL} = 0 V to V _{DD}	-2		4	μA

FSUSB242

Table 5. DC ELECTRICAL CHARACTERISTICS (continued)

(Unless otherwise specified: Recommended T_A and T_J temperature ranges. All typical values are at $T_A = 25^\circ\text{C}$ and $V_{DD} = 4.2\text{ V}$ unless otherwise specified.)

Symbol	Characteristic	V_{DD} (V)	Conditions	$T_A = -40$ to $+85^\circ\text{C}$ $T_J = -40$ to $+125^\circ\text{C}$			Unit
				Min	Typ	Max	
BASIC OPERATION DEVICE							
I_{OZ}	Off State Leakage	2.7 to 5.5	$HSD_{\pm} \geq 0\text{ V}$, $HSD1_{\pm}$, $HSD2_{\pm} \leq 3.6\text{ V}$	-3		5	μA
BASIC OPERATION HSD SWITCH							
R_{ON}	HSD Path On Resistance	2.7 to 5.5	$I_{OUT} = 8\text{ mA}$, $V_{SW} = 0\text{ V}$ to 0.4 V		5		Ω
ΔR_{ON}	HSD Path Delta R_{ON}	2.7 to 5.5	$I_{OUT} = 8\text{ mA}$, $V_{SW} = 0\text{ V}$ to 0.4 V		0.15		Ω
V_{IH}	SEL Input Voltage High	2.7 to 5.5		1.3			V
V_{IM}	SEL Input Voltage Middle (Note 2)	2.7 to 5.5		0.8		1.0	V
V_{IL}	SEL Input Voltage Low	2.7 to 5.5				0.5	V
Z_{float}	Impedance to VDD or GND detected as a Float including $V_{DD} = 0$	2.7 to 5.5		2.5			$\text{M}\Omega$
V_{OV_TRIP1}	Input OVP Lockout for HSD1	2.7 to 5.5	$V_{HSD_{\pm}}$ Rising, SEL = 0	3.6	3.8	4	V
			$V_{HSD_{\pm}}$ Falling, SEL = 0	3.3	3.5		
V_{OV_TRIP2}	Input OVP Lockout for HSD2	2.7 to 5.5	$V_{HSD_{\pm}}$ Rising, SEL = 1	4.5	4.7	4.9	V
			$V_{HSD_{\pm}}$ Falling, SEL = 1	4.2	4.4		
V_{OV_HYS}	Input OVP Hysteresis	2.7 to 5.5			0.3		V
V_{NV_TRIP}	Input Negative Voltage Lockout	2.7 to 5.5	$V_{HSD_{\pm}}$ Falling		-1.0		V
			$V_{HSD_{\pm}}$ Rising		-0.7		
V_{NV_HYS}	Input OVP Hysteresis	2.7 to 5.5			0.3		V
V_{CL}	Clamping Voltage	2.7 to 5.5	$V_{HSD_{\pm}} \geq V_{OV_TRIP}$		4.5		V
V_{UVLO}	Under-Voltage Lockout		V_{DD} Rising		2.4	2.7	V
			V_{DD} Falling		2.3		
TSD	Thermal Shutdown (Note 2)		Shutdown Threshold		150		$^\circ\text{C}$
			Return from Shutdown		130		
			Hysteresis		20		

Product parametric performance is indicated in the Electrical Characteristics for the listed test conditions, unless otherwise noted. Product performance may not be indicated by the Electrical Characteristics if operated under different conditions.

2. Guaranteed by characterization or Design, not production tested.

FSUSB242

Table 6. AC ELECTRICAL CHARACTERISTICS

(Unless otherwise specified: Recommended T_A and T_J temperature ranges. All typical values are at $T_A = 25^\circ\text{C}$ and $V_{DD} = 4.2\text{ V}$ unless otherwise specified.)

Symbol	Characteristic	V_{DD} (V)	Conditions	$T_A = -40$ to $+85^\circ\text{C}$ $T_J = -40$ to $+125^\circ\text{C}$			Unit
				Min	Typ	Max	
HSD SWITCH TIMING PARAMETER							
t_{OVP}	OVP Response Time (Note 33)	2.7 to 5.5	$I_{OUT} = 8\text{ mA}$, $C_L = 5\text{ pF}$, $R_L = 50\ \Omega$, $V_{HSD\pm} = 3.3\text{ V}$ to 4.9 V		0.35		μs
t_{ON}	Turn-On Time, SEL to Output	2.7 to 5.5	$R_L = 50\ \Omega$, $C_L = 5\text{ pF}$		0.1		ms
t_{OFF}	Turn-Off Time, SEL to Output	2.7 to 5.5	$R_L = 50\ \Omega$, $C_L = 5\text{ pF}$, $V_{SW} = 0.8\text{ V}$		0.2		μs
t_{PD}	Propagation Delay (Note 3)	2.7 to 5.5	$R_L = 50\ \Omega$, $C_L = 5\text{ pF}$, $V_{SW} = 0.8\text{ V}$		1.3		ns
t_{BBM}	Break-Before-Make (Note 3)	2.7 to 5.5	$R_L = 50\ \Omega$, $C_L = 5\text{ pF}$, $V_{SW1} = V_{SW2} = 0.8\text{ V}$		50		μs
$t_{SK(P)}$	Skew of Opposite Transitions of the Same Output (Note 3)	2.7 to 5.5	$V_{SW} = 0.2\text{ V}_{diffPP}$, $R_L = 50\ \Omega$, $C_L = 5\text{ pF}$		35		ps
t_J	Total Jitter (Note 3)	2.7 to 5.5	$V_{SW} = 0.2\text{ V}_{diffPP}$, $R_L = 50\ \Omega$, $C_L = 5\text{ pF}$, $t_R = t_F = 500\text{ ps}$ (10–90%) @ 480 Mbps (PRBS = $2^{15} - 1$)		250		ps

HSD± SWITCH CAPACITANCE

C_{IN}	Control Pin Input Capacitance (Note 3)	0			1.5		pF
C_{ON}	HSD± On Capacitance (Note 3)	2.7 to 5.5	SEL = L/H, $f = 240\text{ MHz}$		4		
C_{OFF}	HSD± Off Capacitance (Note 3)	2.7 to 5.5	SEL = Float, $f = 240\text{ MHz}$		3		

HSD SWITCH BANDWIDTH

BW	–3dB SDD21 Bandwidth (Note 3)	2.7 to 5.5	$R_L = 50\ \Omega$, $C_L = 0\text{ pF}$		1000		MHz
			$R_L = 50\ \Omega$, $C_L = 5\text{ pF}$		550		MHz

HSD SWITCH AC PARAMETER

O_{IRR}	Off Isolation (Note 3)	2.7 to 5.5	$R_L = 50\ \Omega$, $f = 240\text{ MHz}$		–35		dB
Xtalk	Non-Adjacent Channel Crosstalk (Note 3)	2.7 to 5.5	$R_L = 50\ \Omega$, $f = 240\text{ MHz}$		–40		dB

Product parametric performance is indicated in the Electrical Characteristics for the listed test conditions, unless otherwise noted. Product performance may not be indicated by the Electrical Characteristics if operated under different conditions.

3. Guaranteed by characterization or Design, not production tested.

TEST DIAGRAMS

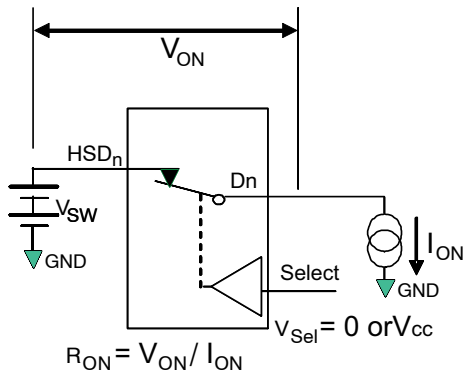
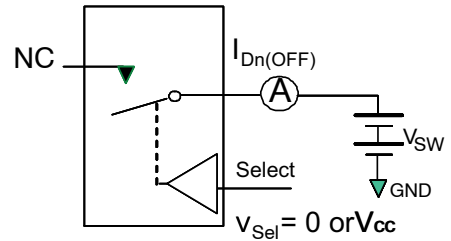
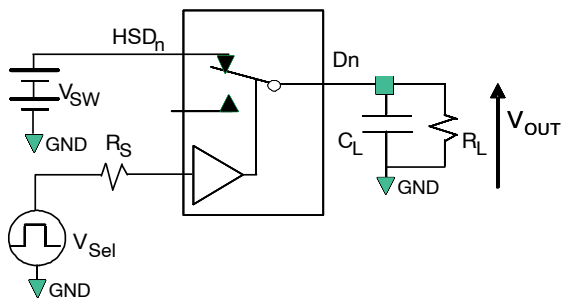

Figure 6. On Resistance



**Each switch port is tested separately

Figure 7. Off Leakage



R_L , R_S , and C_L are functions of the application environment (see AC Tables for specific values)
 C_L includes test fixture and stray capacitance.

Figure 8. AC Test Circuit Load

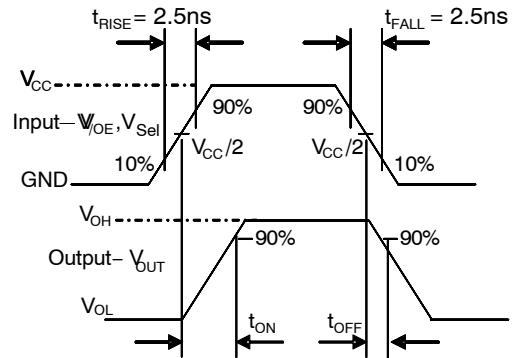

Figure 9. Turn-On / Turn-Off Waveforms

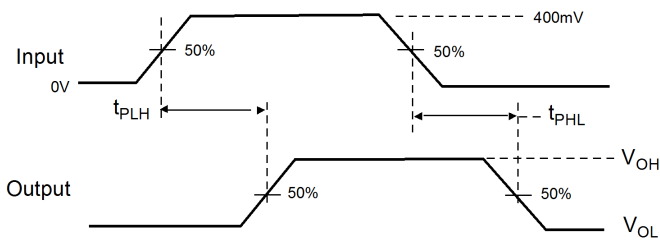

Figure 10. Propagation Delay ($t_{rF} - 500$ ps)

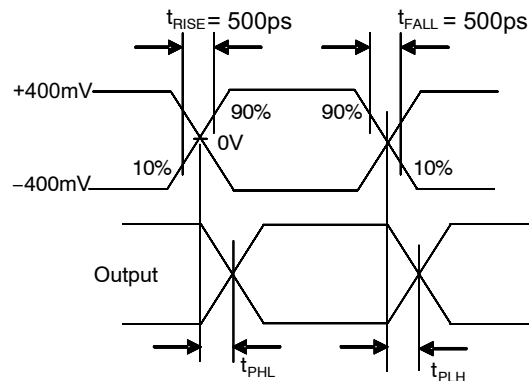

Figure 11. Intra-Pair Skew Test $t_{SK(P)}$

TEST DIAGRAMS (Continued)

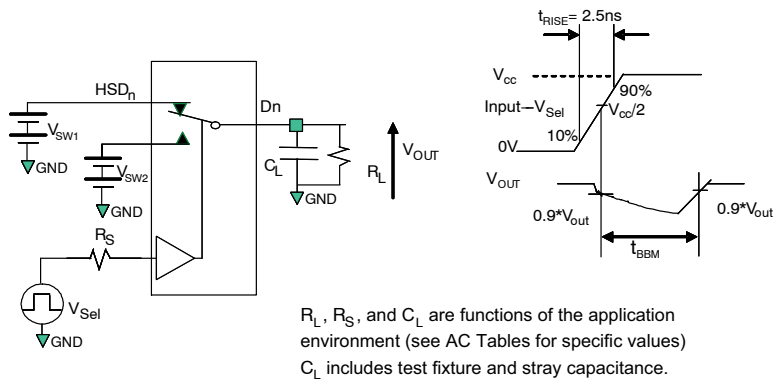

Figure 12. Break-Before-Make Interval Timing

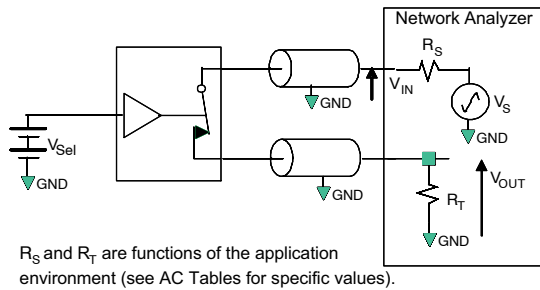

Figure 13. Bandwidth

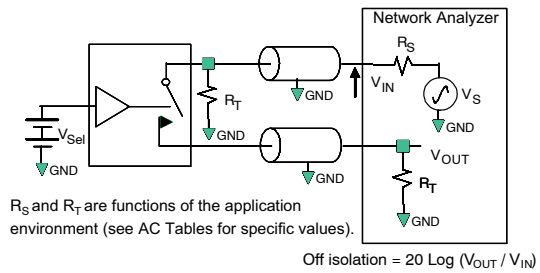

Figure 14. Channel Off Isolation

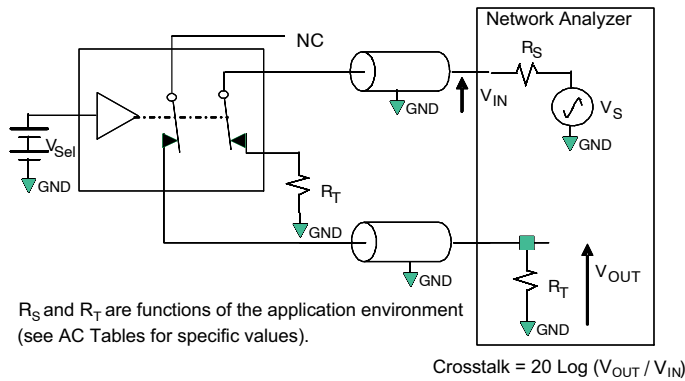

Figure 15. Non-Adjacent Channel-to-Channel Crosstalk

FSUSB242

TEST DIAGRAMS (Continued)

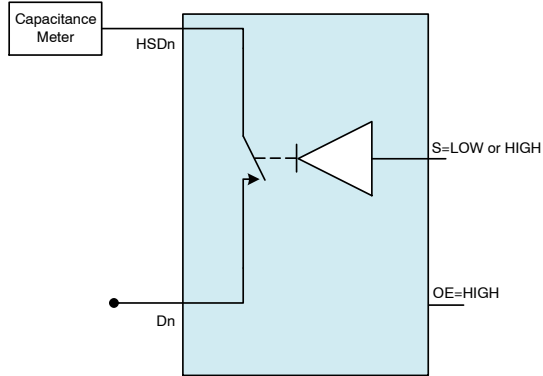

Figure 16. Channel Off Capacitance

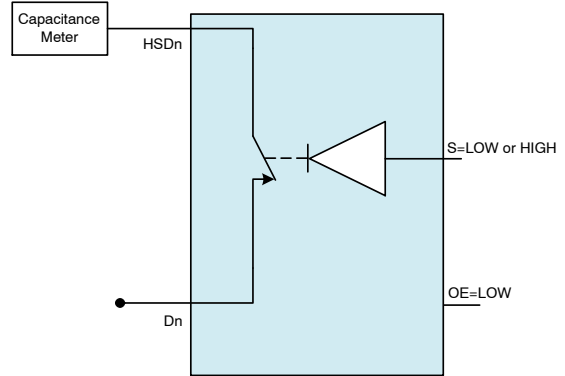

Figure 17. Channel On Capacitance

ORDERING INFORMATION

Table 7. AVAILABLE PART NUMBERS

Part Number	Device Code	Operating Temperature Range	Package	Packing Method†
FSUSB242UCX	MT	-40 to 85°C	9-Ball WLCSP (1.20 x 1.20 mm)	Tape and Reel

†For information on tape and reel specifications, including part orientation and tape sizes, please refer to our Tape and Reel Packaging Specification Brochure, BRD8011/D.

FSUSB242

PACKAGE DIMENSIONS

WLCSP9, 1.2x1.2x0.48
CASE 567UL
ISSUE A

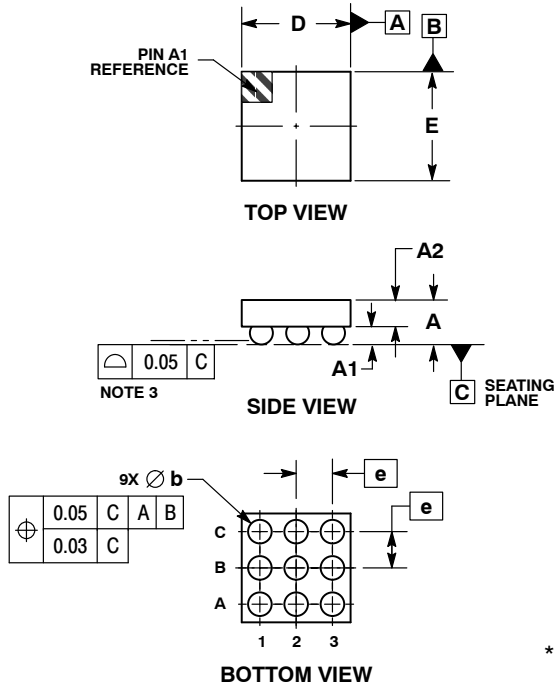

NOTES:

1. DIMENSIONING AND TOLERANCING PER ASME Y14.5M, 2009.
2. CONTROLLING DIMENSION: MILLIMETERS.
3. COPLANARITY APPLIES TO THE SPHERICAL CROWNS OF THE SOLDER BALLS.

DIM	MILLIMETERS		
	MIN	NOM	MAX
A	0.450	0.488	0.526
A1	0.176	0.196	0.216
A2	0.274	0.292	0.310
b	0.24	0.26	0.28
D	1.14	1.20	1.26
E	1.14	1.20	1.26
e	0.40 BSC		

RECOMMENDED SOLDERING FOOTPRINT* (NSMD PAD TYPE)

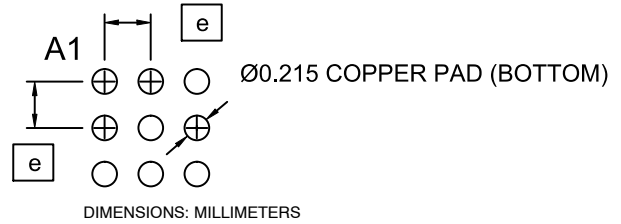

*For additional information on our Pb-Free strategy and soldering details, please download the ON Semiconductor Soldering and Mounting Techniques Reference Manual, SOLDERRM/D.

ON Semiconductor and are trademarks of Semiconductor Components Industries, LLC dba ON Semiconductor or its subsidiaries in the United States and/or other countries. ON Semiconductor owns the rights to a number of patents, trademarks, copyrights, trade secrets, and other intellectual property. A listing of ON Semiconductor's product/patent coverage may be accessed at www.onsemi.com/site/pdf/Patent-Marking.pdf. ON Semiconductor reserves the right to make changes without further notice to any products herein. ON Semiconductor makes no warranty, representation or guarantee regarding the suitability of its products for any particular purpose, nor does ON Semiconductor assume any liability arising out of the application or use of any product or circuit, and specifically disclaims any and all liability, including without limitation special, consequential or incidental damages. Buyer is responsible for its products and applications using ON Semiconductor products, including compliance with all laws, regulations and safety requirements or standards, regardless of any support or applications information provided by ON Semiconductor. "Typical" parameters which may be provided in ON Semiconductor data sheets and/or specifications can and do vary in different applications and actual performance may vary over time. All operating parameters, including "Typicals" must be validated for each customer application by customer's technical experts. ON Semiconductor does not convey any license under its patent rights nor the rights of others. ON Semiconductor products are not designed, intended, or authorized for use as a critical component in life support systems or any FDA Class 3 medical devices or medical devices with a same or similar classification in a foreign jurisdiction or any devices intended for implantation in the human body. Should Buyer purchase or use ON Semiconductor products for any such unintended or unauthorized application, Buyer shall indemnify and hold ON Semiconductor and its officers, employees, subsidiaries, affiliates, and distributors harmless against all claims, costs, damages, and expenses, and reasonable attorney fees arising out of, directly or indirectly, any claim of personal injury or death associated with such unintended or unauthorized use, even if such claim alleges that ON Semiconductor was negligent regarding the design or manufacture of the part. ON Semiconductor is an Equal Opportunity/Affirmative Action Employer. This literature is subject to all applicable copyright laws and is not for resale in any manner.

PUBLICATION ORDERING INFORMATION

LITERATURE FULFILLMENT:
Literature Distribution Center for ON Semiconductor
19521 E. 32nd Pkwy, Aurora, Colorado 80011 USA
Phone: 303-675-2175 or 800-344-3860 Toll Free USA/Canada
Fax: 303-675-2176 or 800-344-3867 Toll Free USA/Canada
Email: orderlit@onsemi.com

N. American Technical Support: 800-282-9855 Toll Free USA/Canada
Europe, Middle East and Africa Technical Support:
Phone: 421 33 790 2910
Japan Customer Focus Center
Phone: 81-3-5817-1050

ON Semiconductor Website: www.onsemi.com
Order Literature: <http://www.onsemi.com/orderlit>

For additional information, please contact your local Sales Representative