



Chipsmall Limited consists of a professional team with an average of over 10 year of expertise in the distribution of electronic components. Based in Hongkong, we have already established firm and mutual-benefit business relationships with customers from,Europe,America and south Asia,supplying obsolete and hard-to-find components to meet their specific needs.

With the principle of “Quality Parts,Customers Priority,Honest Operation,and Considerate Service”,our business mainly focus on the distribution of electronic components. Line cards we deal with include Microchip,ALPS,ROHM,Xilinx,Pulse,ON,Everlight and Freescale. Main products comprise IC,Modules,Potentiometer,IC Socket,Relay,Connector.Our parts cover such applications as commercial,industrial, and automotives areas.

We are looking forward to setting up business relationship with you and hope to provide you with the best service and solution. Let us make a better world for our industry!



Contact us

Tel: +86-755-8981 8866 Fax: +86-755-8427 6832

Email & Skype: info@chipsmall.com Web: www.chipsmall.com

Address: A1208, Overseas Decoration Building, #122 Zhenhua RD., Futian, Shenzhen, China





Is Now Part of



ON Semiconductor®

To learn more about ON Semiconductor, please visit our website at
www.onsemi.com

ON Semiconductor and the ON Semiconductor logo are trademarks of Semiconductor Components Industries, LLC dba ON Semiconductor or its subsidiaries in the United States and/or other countries. ON Semiconductor owns the rights to a number of patents, trademarks, copyrights, trade secrets, and other intellectual property. A listing of ON Semiconductor's product/patent coverage may be accessed at www.onsemi.com/site/pdf/Patent-Marking.pdf. ON Semiconductor reserves the right to make changes without further notice to any products herein. ON Semiconductor makes no warranty, representation or guarantee regarding the suitability of its products for any particular purpose, nor does ON Semiconductor assume any liability arising out of the application or use of any product or circuit, and specifically disclaims any and all liability, including without limitation special, consequential or incidental damages. Buyer is responsible for its products and applications using ON Semiconductor products, including compliance with all laws, regulations and safety requirements or standards, regardless of any support or applications information provided by ON Semiconductor. "Typical" parameters which may be provided in ON Semiconductor data sheets and/or specifications can and do vary in different applications and actual performance may vary over time. All operating parameters, including "Typicals" must be validated for each customer application by customer's technical experts. ON Semiconductor does not convey any license under its patent rights nor the rights of others. ON Semiconductor products are not designed, intended, or authorized for use as a critical component in life support systems or any FDA Class 3 medical devices or medical devices with a same or similar classification in a foreign jurisdiction or any devices intended for implantation in the human body. Should Buyer purchase or use ON Semiconductor products for any such unintended or unauthorized application, Buyer shall indemnify and hold ON Semiconductor and its officers, employees, subsidiaries, affiliates, and distributors harmless against all claims, costs, damages, and expenses, and reasonable attorney fees arising out of, directly or indirectly, any claim of personal injury or death associated with such unintended or unauthorized use, even if such claim alleges that ON Semiconductor was negligent regarding the design or manufacture of the part. ON Semiconductor is an Equal Opportunity/Affirmative Action Employer. This literature is subject to all applicable copyright laws and is not for resale in any manner.



May 2015

FSV1045V

10 A, 45 V Ultra-Low VF Schottky Rectifier

Features

- Ultra-Low Forward Voltage Drop:
 - 0.41 V Typical at 10 A, $T_A = 25^\circ\text{C}$
 - 0.44 V Maximum at 10 A, $T_A = 25^\circ\text{C}$
- Low Thermal Resistance
- Very Low Profile: Typical Height of 1.1 mm
- RoHS Compliant
- Halogen Free
- Meets MSL 1 per JESD22-A111 Full-Body Solder Immersion

Applications

- Mobile Charger
- Solar Panel
- Reverse Polarity Protection

Description

The FSV1045V schottky rectifier offers break-through size and performance. The device is optimized for mobile charger applications. It sinks only 18 mA reverse current at high temperature and provides forward voltage drop of 0.18 V at 1 A operating current in a charger design.

All this capability is packed into a small, flat-lead, TO-277 package, optimized for space-constrained applications. The FSV1045V supports a typical Z height of 1.1 mm. It is RoHS compliant and halogen free. It is also qualified for a wave soldering process.

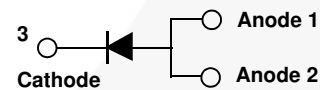
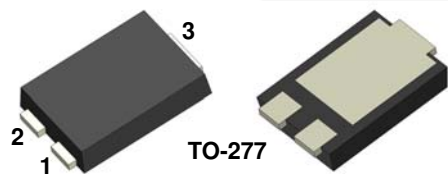

Ordering Information

| Part Number | Top Mark | Package | Packing Method |
|-------------|----------|-----------|----------------|
| FSV1045V | FSV1045V | TO-277 3L | Tape and Reel |

FSV1045V — 10 A, 45 V Ultra-Low VF Schottky Rectifier

Absolute Maximum Ratings⁽¹⁾

Stresses exceeding the absolute maximum ratings may damage the device. The device may not function or be operable above the recommended operating conditions and stressing the parts to these levels is not recommended. In addition, extended exposure to stresses above the recommended operating conditions may affect device reliability. The absolute maximum ratings are stress ratings only. Values are at $T_A = 25^\circ\text{C}$ unless otherwise noted.

| Symbol | Parameter | | Value | Unit |
|-----------|--|----------------------------------|-------------|------------------|
| V_{RRM} | Peak Repetitive Reverse Voltage | | 45 | V |
| V_{RWM} | Working Peak Reverse Voltage | | 45 | V |
| V_{RMS} | RMS Reverse Voltage | | 32 | V |
| V_R | DC Blocking Voltage | | 45 | V |
| I_O | Average Rectified Output Current ⁽²⁾ | $T_L = 105^\circ\text{C}$ | 10 | A |
| I_{FSM} | Non-Repetitive Peak Forward Surge Current ⁽³⁾ | | 300 | A |
| C_J | Typical Junction Capacitance | $V_R = 4\text{ V}, 1\text{ MHz}$ | 820 | pF |
| T_J | Operating Junction Temperature Range | | -55 to +150 | $^\circ\text{C}$ |
| T_{STG} | Storage Temperature Range | | -55 to +150 | $^\circ\text{C}$ |

Notes:

- All tests conducted at $T_A = T_J = 25^\circ\text{C}$ unless otherwise noted.
- Mounted on 30 mm x 30 mm FR4 PCB.
- Pulse condition: 8.3 ms single half-sine wave. Test method is compliant with MIL standard. (MIL-STD-750E)

Thermal Characteristics⁽⁴⁾

Values are at $T_A = 25^\circ\text{C}$ unless otherwise noted.

| Symbol | Parameter | Minimum Land Pattern | Maximum Land Pattern | Unit |
|-----------------|--|----------------------|----------------------|---------------------------|
| $R_{\theta JA}$ | Junction-to-Ambient Thermal Resistance | 100 | 40 | $^\circ\text{C}/\text{W}$ |
| ψ_{JL} | Junction-to-Lead Thermal Characteristics, Thermocouple Soldered to Anode | 15 | 12 | $^\circ\text{C}/\text{W}$ |
| | Junction-to-Lead Thermal Characteristics, Thermocouple Soldered to Cathode | 6 | 5 | |

Note:

- The thermal resistances ($R_{\theta JA}$ & ψ_{JL}) are characterized with device mounted on the following FR4 printed circuit boards, as shown in Figure 1 and Figure 2. PCB size: 76.2 x 114.3 mm. Minimum land pattern size: 4.9 x 4.8 mm (big pattern, x1), 1.4 x 1.52 mm (small pattern, x2). Maximum land pattern size: 30 x 30 mm (pattern, x2). Force line trace size = 55 mils, sense line trace size = 4 mils.



Figure 1. Minimum Land Pattern of 2 oz Copper

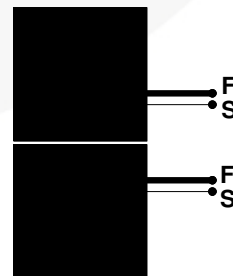

Figure 2. Maximum Land Pattern of 2 oz Copper

Electrical Characteristics

Values are at $T_A = 25^\circ\text{C}$ unless otherwise noted.

| Symbol | Parameter | Conditions | Min. | Typ. | Max. | Unit |
|----------|----------------------|-------------------------|---------------------------|-------|-------|------|
| V_{BR} | Breakdown Voltage | $I_T = 500 \mu\text{A}$ | 45 | | | V |
| V_F | Forward Voltage Drop | $I_F = 1 \text{ A}$ | $T_A = 25^\circ\text{C}$ | 0.28 | 0.44 | V |
| | | $I_F = 10 \text{ A}$ | | 0.41 | | |
| | | $I_F = 1 \text{ A}$ | $T_A = 125^\circ\text{C}$ | 0.18 | 0.39 | |
| | | $I_F = 10 \text{ A}$ | | 0.36 | | |
| I_R | Maximum Leakage | $V = V_{RWM}$ | $T_A = 25^\circ\text{C}$ | 0.065 | 0.220 | mA |
| | | | $T_A = 125^\circ\text{C}$ | 19 | 32 | |



Typical Performance Characteristics

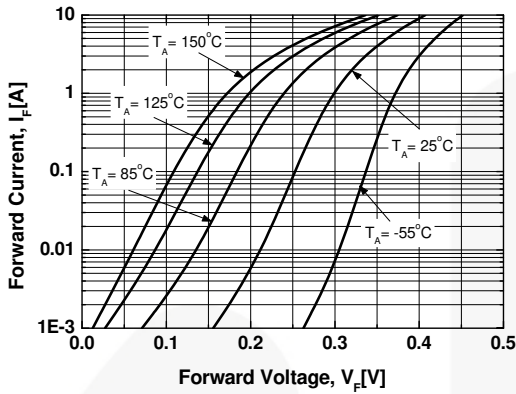

Figure 3. Forward Current Characteristics

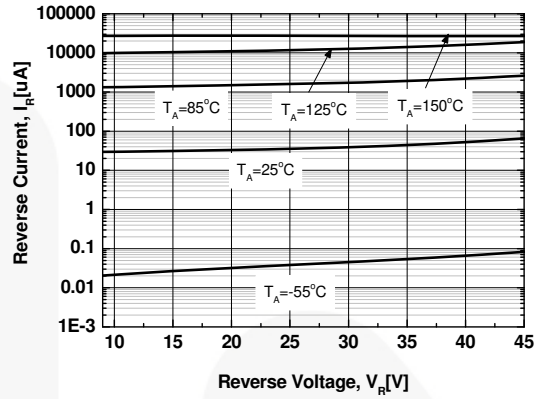

Figure 4. Typical Reverse Characteristics

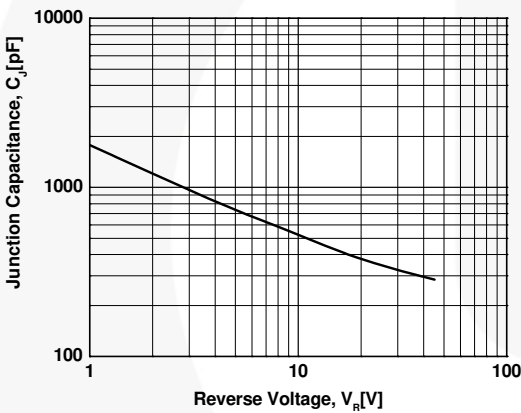

Figure 5. Typical Junction Capacitance

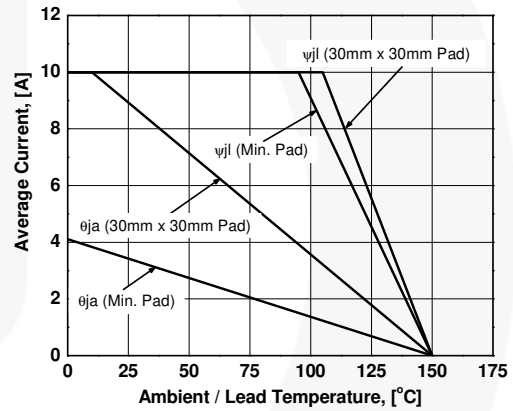

Figure 6. Forward Current Derating Curve

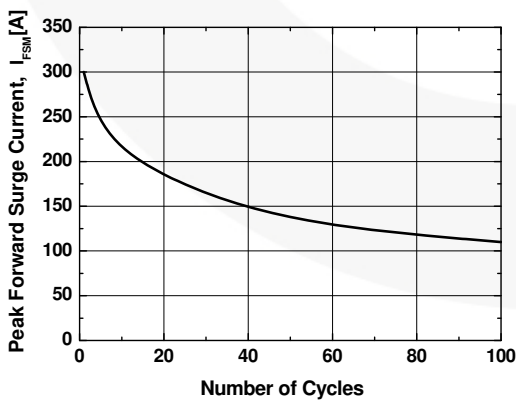
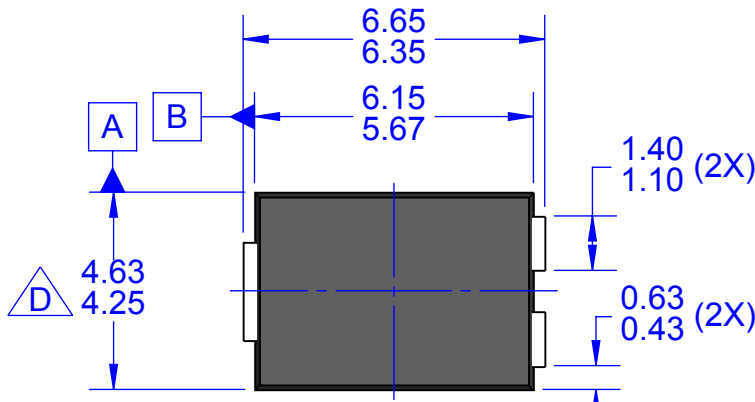
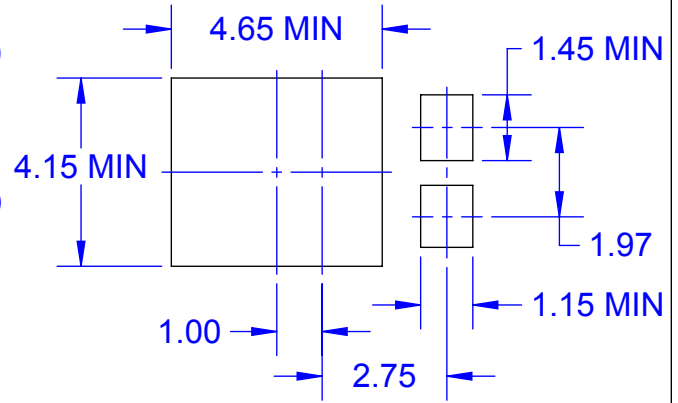

Figure 7. Surge Current Derating Curve



TOP VIEW



LAND PATTERN RECOMMENDATION

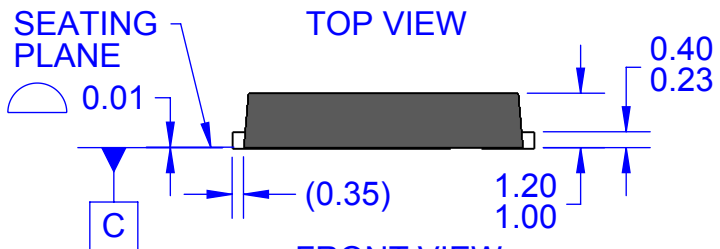

FRONT VIEW

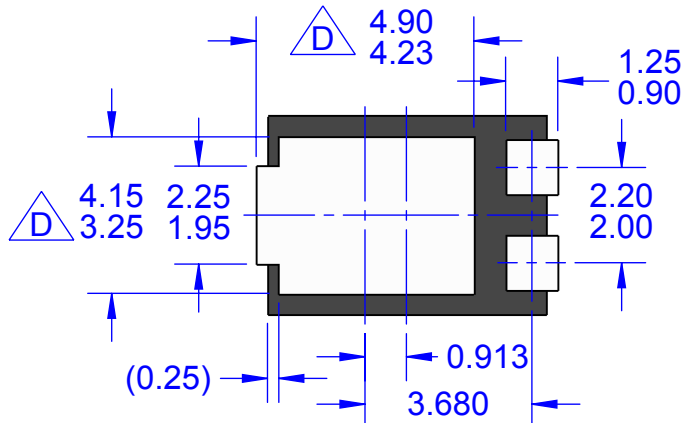

BOTTOM VIEW

NOTES: UNLESS OTHERWISE SPECIFIED

- A. PACKAGE REFERENCE: JEDEC TO-277
- B. DIMENSIONS ARE EXCLUSIVE OF BURRS, MOLD FLASH, AND TIE BAR EXTRUSIONS.
- C. ALL DIMENSIONS ARE IN MILLIMETERS.

- \triangle D DOES NOT COMPLY TO JEDEC STANDARD VALUE.
- E. DRAWING FILENAME: MKT-TO277A03rev5

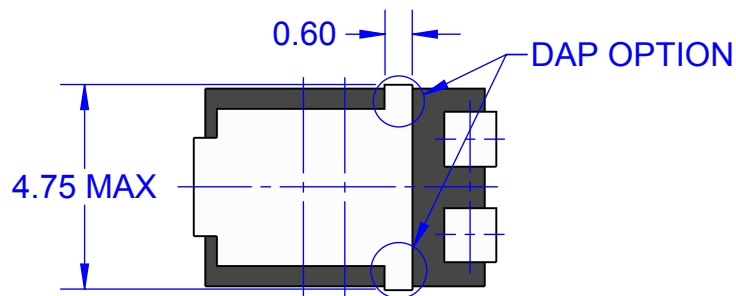

BOTTOM VIEW - DAP OPTION



ON Semiconductor and  are trademarks of Semiconductor Components Industries, LLC dba ON Semiconductor or its subsidiaries in the United States and/or other countries. ON Semiconductor owns the rights to a number of patents, trademarks, copyrights, trade secrets, and other intellectual property. A listing of ON Semiconductor's product/patent coverage may be accessed at www.onsemi.com/site/pdf/Patent-Marking.pdf. ON Semiconductor reserves the right to make changes without further notice to any products herein. ON Semiconductor makes no warranty, representation or guarantee regarding the suitability of its products for any particular purpose, nor does ON Semiconductor assume any liability arising out of the application or use of any product or circuit, and specifically disclaims any and all liability, including without limitation special, consequential or incidental damages. Buyer is responsible for its products and applications using ON Semiconductor products, including compliance with all laws, regulations and safety requirements or standards, regardless of any support or applications information provided by ON Semiconductor. "Typical" parameters which may be provided in ON Semiconductor data sheets and/or specifications can and do vary in different applications and actual performance may vary over time. All operating parameters, including "Typicals" must be validated for each customer application by customer's technical experts. ON Semiconductor does not convey any license under its patent rights nor the rights of others. ON Semiconductor products are not designed, intended, or authorized for use as a critical component in life support systems or any FDA Class 3 medical devices or medical devices with a same or similar classification in a foreign jurisdiction or any devices intended for implantation in the human body. Should Buyer purchase or use ON Semiconductor products for any such unintended or unauthorized application, Buyer shall indemnify and hold ON Semiconductor and its officers, employees, subsidiaries, affiliates, and distributors harmless against all claims, costs, damages, and expenses, and reasonable attorney fees arising out of, directly or indirectly, any claim of personal injury or death associated with such unintended or unauthorized use, even if such claim alleges that ON Semiconductor was negligent regarding the design or manufacture of the part. ON Semiconductor is an Equal Opportunity/Affirmative Action Employer. This literature is subject to all applicable copyright laws and is not for resale in any manner.

PUBLICATION ORDERING INFORMATION

LITERATURE FULFILLMENT:

Literature Distribution Center for ON Semiconductor
19521 E. 32nd Pkwy, Aurora, Colorado 80011 USA
Phone: 303-675-2175 or 800-344-3860 Toll Free USA/Canada
Fax: 303-675-2176 or 800-344-3867 Toll Free USA/Canada
Email: orderlit@onsemi.com

N. American Technical Support: 800-282-9855 Toll Free
USA/Canada
Europe, Middle East and Africa Technical Support:
Phone: 421 33 790 2910
Japan Customer Focus Center
Phone: 81-3-5817-1050

ON Semiconductor Website: www.onsemi.com
Order Literature: <http://www.onsemi.com/orderlit>
For additional information, please contact your local
Sales Representative