



Chipsmall Limited consists of a professional team with an average of over 10 year of expertise in the distribution of electronic components. Based in Hongkong, we have already established firm and mutual-benefit business relationships with customers from,Europe,America and south Asia,supplying obsolete and hard-to-find components to meet their specific needs.

With the principle of “Quality Parts,Customers Priority,Honest Operation,and Considerate Service”,our business mainly focus on the distribution of electronic components. Line cards we deal with include Microchip,ALPS,ROHM,Xilinx,Pulse,ON,Everlight and Freescale. Main products comprise IC,Modules,Potentiometer,IC Socket,Relay,Connector.Our parts cover such applications as commercial,industrial, and automotives areas.

We are looking forward to setting up business relationship with you and hope to provide you with the best service and solution. Let us make a better world for our industry!



Contact us

Tel: +86-755-8981 8866 Fax: +86-755-8427 6832

Email & Skype: info@chipsmall.com Web: www.chipsmall.com

Address: A1208, Overseas Decoration Building, #122 Zhenhua RD., Futian, Shenzhen, China



Future Technology Devices International Ltd.

FT231X

(USB to FULL HANDSHAKE UART IC)

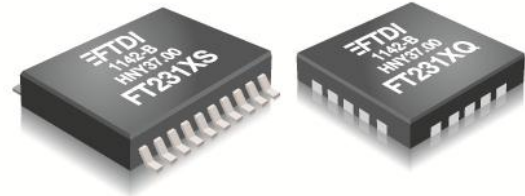

The FT231X is a USB to serial UART interface with full modem control and the following advanced features:

- Single chip USB to asynchronous serial data transfer interface.
- Entire USB protocol handled on the chip. No USB specific firmware programming required.
- Fully integrated 2048 byte multi-time-programmable (MTP) memory, storing device descriptors and CBUS I/O configuration.
- Fully integrated clock generation with no external crystal required plus optional clock output selection enabling glue-less interface to external MCU or FPGA.
- Data transfer rates from 300 baud to 3 Mbaud (RS422, RS485, and RS232) at TTL levels.
- 512 byte receive buffer and 512 byte transmit buffer utilising buffer smoothing technology to allow for high data throughput.
- FTDI's royalty-free Virtual Com Port (VCP) and Direct (D2XX) drivers eliminate the requirement for USB driver development in most cases.
- Configurable CBUS I/O pins.
- Transmit and receive LED drive signals.
- UART interface support for 7 or 8 data bits, 1 or 2 stop bits and odd / even / mark / space no parity
- Synchronous and asynchronous bit bang interface options with RD# and WR# strobes.
- USB Battery Charger Detection. Allows for USB peripheral devices to detect the presence of a higher power source to enable improved charging.
- Device supplied pre-programmed with unique USB serial number.
- USB Power Configurations; supports bus-powered, self-powered and bus-powered with power switching
- Integrated +3.3V level converter for USB I/O.
- True 3.3V CMOS drive output and TTL input; Operates down to 1V8 with external pull-ups. Tolerant of 5V input.
- Configurable I/O pin output drive strength; 4 mA(min) and 16 mA(max).
- Integrated power-on-reset circuit.
- Fully integrated AVCC supply filtering - no external filtering required.
- UART signal inversion option.
- + 5V Single Supply Operation.
- Internal 3V3/1V8 LDO regulators
- Low operating and USB suspend current; 8mA (active-typ) and 125uA (suspend-typ).
- UHCI/OHCI/EHCI host controller compatible
- USB 2.0 Full Speed capable.
- Extended operating temperature range; -40 to 85°C.
- Available in compact, Pb-free, 20 Pin SSOP and QFN packages (both RoHS compliant).

Neither the whole nor any part of the information contained in, or the product described in this manual, may be adapted or reproduced in any material or electronic form without the prior written consent of the copyright holder. This product and its documentation are supplied on an as-is basis and no warranty as to their suitability for any particular purpose is either made or implied. Future Technology Devices International Ltd will not accept any claim for damages howsoever arising as a result of use or failure of this product. Your statutory rights are not affected. This product or any variant of it is not intended for use in any medical appliance, device or system in which the failure of the product might reasonably be expected to result in personal injury. This document provides preliminary information that may be subject to change without notice. No freedom to use patents or other intellectual property rights is implied by the publication of this document. Future Technology Devices International Ltd, Unit 1, 2 Seaward Place, Centurion Business Park, Glasgow G41 1HH United Kingdom. Scotland Registered Company Number: SC136640

1 Typical Applications

- USB to RS232/RS422/RS485 Converters
- Upgrading Legacy Peripherals to USB
- Utilising USB to add system modularity
- Incorporate USB interface to enable PC transfers for development system communication
- Cellular and Cordless Phone USB data transfer cables and interfaces
- Interfacing MCU/PLD/FPGA based designs to add USB connectivity
- USB Audio and Low Bandwidth Video data transfer
- USB Smart Card Readers
- USB Instrumentation
- USB Industrial Control
- USB MP3 Player Interface
- USB FLASH Card Reader and Writers
- Set Top Box PC - USB interface
- USB Digital Camera Interface
- USB Hardware Modems
- USB Wireless Modems
- USB Bar Code Readers
- USB dongle implementations for Software/ Hardware Encryption and Wireless Modules
- Detection of dedicated battery charger ports for high current charging of batteries in portable devices.

1.1 Driver Support

Royalty free VIRTUAL COM PORT (VCP) DRIVERS for...

- Windows 8 32,64-bit
- Windows 7 32,64-bit
- Windows XP and XP 64-bit
- Windows Vista and Vista 64-bit
- Windows XP Embedded
- Windows CE 4.2, 5.0 and 6.0
- Mac OS-X
- Linux 3.2 and greater
- Android

Royalty free D2XX *Direct Drivers* (USB Drivers + DLL S/W Interface)

- Windows 8 32,64-bit
- Windows 7 32,64-bit
- Windows XP and XP 64-bit
- Windows Vista and Vista 64-bit
- Windows XP Embedded
- Windows CE 4.2, 5.0 and 6.0
- MAC OS-X
- Linux 2.6 and greater
- Android

The drivers listed above are all available to download for free from FTDI website (www.ftdichip.com). Various 3rd party drivers are also available for other operating systems - see FTDI website (www.ftdichip.com) for details.

For driver installation, please refer to <http://www.ftdichip.com/Documents/InstallGuides.htm>

1.2 Part Numbers

Part Number	Package
FT231XQ-x	20 Pin QFN
FT231XS-x	20 Pin SSOP

Note: Packing codes for x is:

- R: Taped and Reel, (SSOP is 2,000pcs per reel, QFN is 5,000pcs per reel).
- U: Tube packing, 58pcs per tube (SSOP only)
- T: Tray packing, 490pcs per tray (QFN only)

For example: FT231XQ-R is 5,000pcs taped and reel packing

1.3 USB Compliant

The FT231X is fully compliant with the USB 2.0 specification and has been given the USB-IF Test-ID (TID) 40001464 (Rev D).



2 FT231X Block Diagram

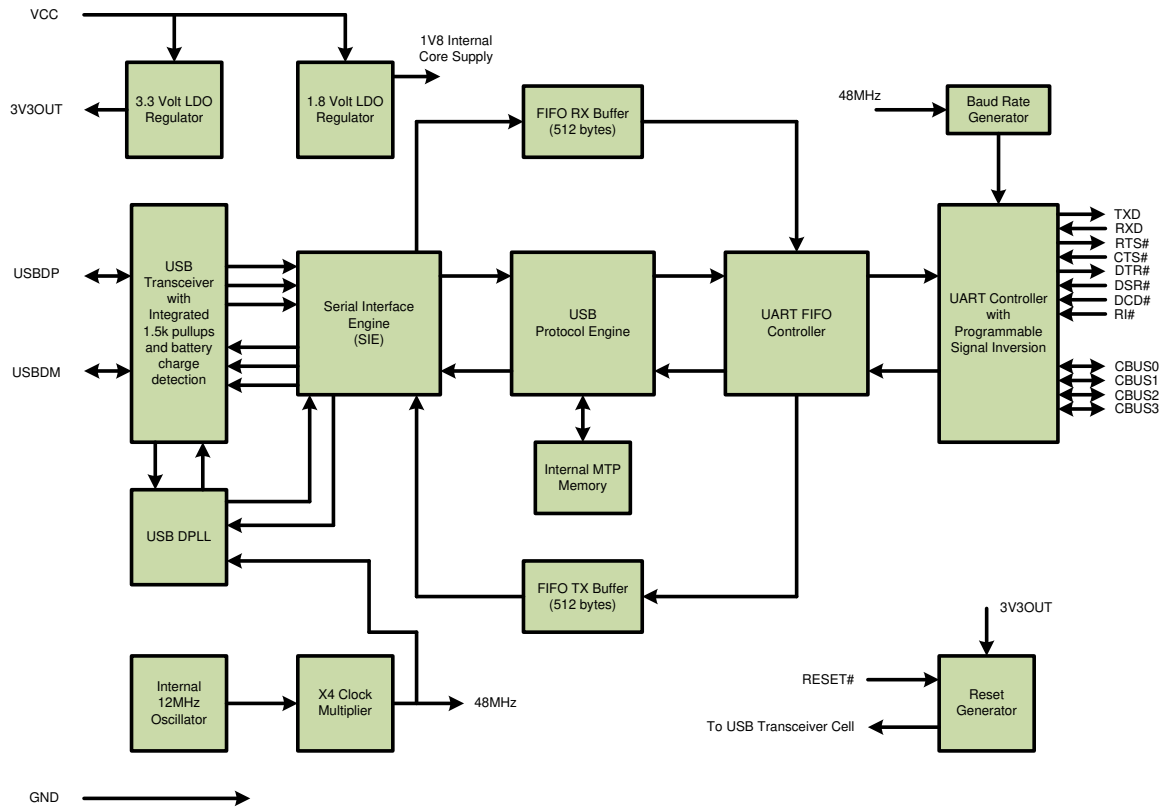

Figure 2.1 FT231X Block Diagram

For a description of each function please refer to Section 4.

Table of Contents

1	Typical Applications	2
1.1	Driver Support	2
1.2	Part Numbers.....	2
1.3	USB Compliant	3
2	FT231X Block Diagram	4
3	Device Pin Out and Signal Description	7
3.1	20-LD QFN Package	7
3.1.1	QFN Package PinOut Description	7
3.2	20-LD SSOP Package	9
3.2.1	SSOP Package PinOut Description	9
3.3	CBUS Signal Options	10
4	Function Description	13
4.1	Key Features.....	13
4.2	Functional Block Descriptions	13
5	Devices Characteristics and Ratings	16
5.1	Absolute Maximum Ratings.....	16
5.2	ESD and Latch-up Specifications.....	16
5.3	DC Characteristics.....	17
5.4	MTP Memory Reliability Characteristics	21
5.5	Internal Clock Characteristics.....	21
6	USB Power Configurations	22
6.1	USB Bus Powered Configuration	22
6.2	Self Powered Configuration	23
6.3	USB Bus Powered with Power Switching Configuration	24
7	Application Examples	25
7.1	USB to RS232 Converter	25
7.2	USB to RS485 Coverter	26
7.3	USB to RS422 Converter	27
7.4	USB Battery Charging Detection	28
7.5	LED Interface.....	30
8	Internal MTP Memory Configuration	32
8.1	Default Values	32
8.2	Methods of Programming the MTP Memory.....	34
8.2.1	Programming the MTP memory over USB.....	34
8.3	Memory Map	34

9	Package Parameters	36
9.1	SSOP-20 Package Mechanical Dimensions	36
9.2	SSOP-20 Package Markings	37
9.3	QFN-20 Package Mechanical Dimensions	38
9.4	QFN-20 Package Markings	39
9.5	Solder Reflow Profile	40
10	Contact Information	41
	Appendix A – References	42
	Appendix B – List of Figures and Tables	42
	Appendix C – Revision History	44

3 Device Pin Out and Signal Description

3.1 20-LD QFN Package

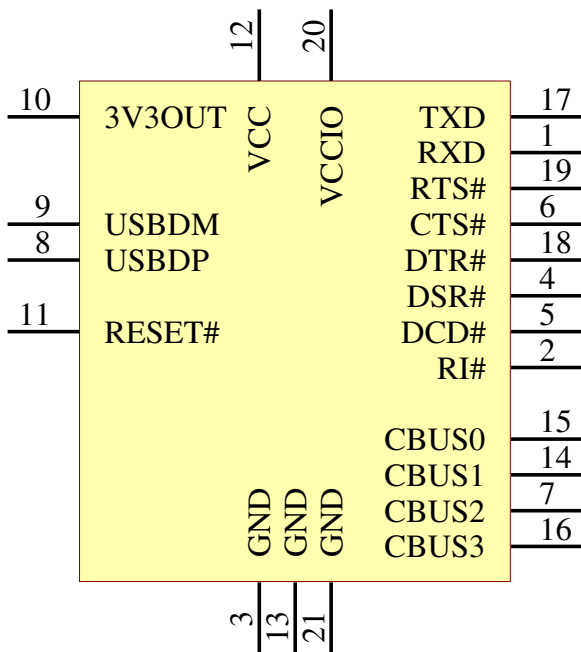

Figure 3.1 QFN Schematic Symbol

3.1.1 QFN Package PinOut Description

Note: # denotes an active low signal.

Pin No.	Name	Type	Description
12	** VCC	POWER Input	5 V or 3V3 supply to IC
20	VCCIO	POWER Input	1V8 – 3V3 supply for the IO cells
10	** 3V3OUT	POWER Output	3V3 output at 50mA. May be used to power VCCIO. When VCC is 3V3; pin 10 is an input pin and should be connected to pin 12.
3, 13	GND	POWER Input	0V Ground input.

Table 3.1 Power and Ground

*Pin 21 on the symbol is the pad under the centre of the chip package and should be connected to GND

** If VCC is 3V3 then 3V3OUT must also be driven with 3V3 input

Pin No.	Name	Type	Description
9	USBDM	INPUT	USB Data Signal Minus.
8	USBDP	INPUT	USB Data Signal Plus.
11	RESET#	INPUT	Reset input (active low).

Table 3.2 Common Function pins

Pin No.	Name	Type	Description
17	TXD	Output	Transmit Asynchronous Data Output.
1	RXD	Input	Receiving Asynchronous Data Input.
19	RTS#	Output	Request to Send Control Output / Handshake Signal.
6	CTS#	Input	Clear To Send Control Input / Handshake Signal.
18	DTR#	Output	Data Terminal Ready Control Output / Handshake Signal.
4	DSR#	Input	Data Set Ready Control Input / Handshake Signal.
5	DCD#	Input	Data Carrier Detect Control Input.
2	RI#	Input	Ring Indicator input for remote wake up.
15	CBUS0	I/O	Configurable CBUS I/O Pin. Function of this pin is configured in the device MTP memory. The default configuration is TXDEN. See CBUS Signal Options, Table 3.7.
14	CBUS1	I/O	Configurable CBUS I/O Pin. Function of this pin is configured in the device MTP memory. The default configuration is RXLED#. See CBUS Signal Options, Table 3.7.
7	CBUS2	I/O	Configurable CBUS I/O Pin. Function of this pin is configured in the device MTP memory. The default configuration is TXLED#. See CBUS Signal Options, Table 3.7.
16	CBUS3	I/O	Configurable CBUS I/O Pin. Function of this pin is configured in the device MTP memory. The default configuration is SLEEP#. See CBUS Signal Options, Table 3.7.

Table 3.3 UART Interface and CBUS Group (see note 1)
Notes:

- When used in Input Mode, the input pins are pulled to VCCIO via internal 75k Ω (approx) resistors. These pins can be programmed to gently pull low during USB suspend (PWREN# = "1") by setting an option in the MTP memory.

3.2 20-LD SSOP Package

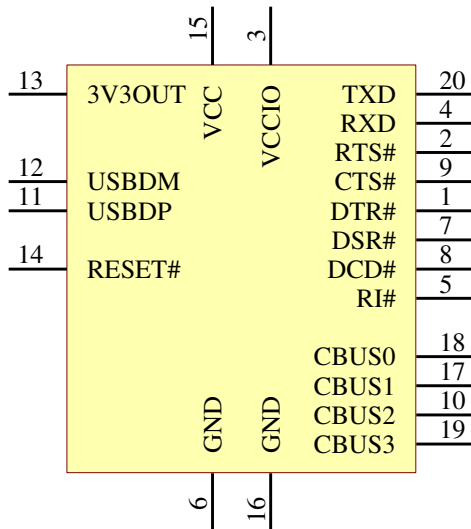

Figure 3.2 SSOP Schematic Symbol

3.2.1 SSOP Package PinOut Description

Note: # denotes an active low signal.

Pin No.	Name	Type	Description
15	** VCC	POWER Input	5 V or 3V3 supply to IC
3	VCCIO	POWER Input	1V8 – 3V3 supply for the IO cells
13	** 3V3OUT	POWER Output	3V3 output at 50mA. May be used to power VCCIO. When VCC is 3V3, pin 13 is an input pin.
6, 16	GND	POWER Input	0V Ground input.

Table 3.4 Power and Ground

** If VCC is 3V3 then 3V3OUT must also be driven with 3V3 input

Pin No.	Name	Type	Description
12	USBDM	INPUT	USB Data Signal Minus.
11	USBDP	INPUT	USB Data Signal Plus.
14	RESET#	INPUT	Reset input (active low).

Table 3.5 Common Function pins

Pin No.	Name	Type	Description
20	TXD	Output	Transmit Asynchronous Data Output.
4	RXD	Input	Receiving Asynchronous Data Input.
2	RTS#	Output	Request to Send Control Output / Handshake Signal.
9	CTS#	Input	Clear To Send Control Input / Handshake Signal.
1	DTR#	Output	Data Terminal Ready Control Output / Handshake Signal.
7	DSR#	Input	Data Set Ready Control Input / Handshake Signal.
8	DCD#	Input	Data Carrier Detect Control Input.
5	RI#	Input	Ring Indicator input for remote wake up.
18	CBUS0	I/O	Configurable CBUS I/O Pin. Function of this pin is configured in the device MTP memory. The default configuration is TXDEN. See CBUS Signal Options, Table 3.7.
17	CBUS1	I/O	Configurable CBUS I/O Pin. Function of this pin is configured in the device MTP memory. The default configuration is RXLED#. See CBUS Signal Options, Table 3.7.
10	CBUS2	I/O	Configurable CBUS I/O Pin. Function of this pin is configured in the device MTP memory. The default configuration is TXLED#. See CBUS Signal Options, Table 3.7.
19	CBUS3	I/O	Configurable CBUS I/O Pin. Function of this pin is configured in the device MTP memory. The default configuration is SLEEP#. See CBUS Signal Options, Table 3.7.

Table 3.6 UART Interface and CBUS Group (see note 1)
Notes:

- 1 When used in Input Mode, the input pins are pulled to VCCIO via internal 75k Ω (approx) resistors. These pins can be programmed to gently pull low during USB suspend (PWREN# = "1") by setting an option in the MTP memory.

3.3 CBUS Signal Options

The following options can be configured on the CBUS I/O pins. CBUS signal options are common to both package versions of the FT231X. These options can be configured in the internal MTP memory using the software utility FT_PPLOG, which can be downloaded from the FTDI Utilities (www.ftdichip.com). The default configuration is described in Section 8.

CBUS Signal Option	Available On CBUS Pin	Description
TRI-STATE	CBUS0, CBUS1, CBUS2, CBUS3	IO Pad is tri-stated
DRIVE 1	CBUS0, CBUS1, CBUS2, CBUS3	Output a constant 1
DRIVE 0	CBUS0, CBUS1, CBUS2, CBUS3	Output a constant 0
TXDEN	CBUS0, CBUS1, CBUS2, CBUS3	Enable transmit data for RS485
PWREN#	CBUS0, CBUS1, CBUS2, CBUS3	Output is low after the device has been configured by USB, then high during USB suspend mode. This output can be used to control power to external logic P-Channel logic level MOSFET switch. Enable the interface pull-down option when using the PWREN# in this way.
TXLED#	CBUS0, CBUS1, CBUS2, CBUS3	Transmit data LED drive – pulses low when transmitting data via USB. See Section 7.5 for more details.
RXLED#	CBUS0, CBUS1, CBUS2, CBUS3	Receive data LED drive – pulses low when receiving data via USB. See Section 7.5 for more details.
TX&RXLED#	CBUS0, CBUS1, CBUS2, CBUS3	LED drive – pulses low when transmitting or receiving data via USB. See Section 7.5 for more details.
SLEEP#	CBUS0, CBUS1, CBUS2, CBUS3	Goes low during USB suspend mode. Typically used to power down an external TTL to RS232 level converter IC in USB to RS232 converter designs.
CLK24MHz	CBUS0, CBUS1, CBUS2, CBUS3	24 MHz Clock output.*
CLK12MHz	CBUS0, CBUS1, CBUS2, CBUS3	12 MHz Clock output.*
CLK6MHz	CBUS0, CBUS1, CBUS2, CBUS3	6 MHz Clock output.*
GPIO	CBUS0, CBUS1, CBUS2, CBUS3	CBUS bit bang mode option. Allows up to 4 of the CBUS pins to be used as general purpose I/O. Configured individually for CBUS0, CBUS1, CBUS2 and CBUS3 in the internal MTP memory. A separate application note, AN232R-01, available from FTDI website (www.ftdichip.com) describes in more detail how to use CBUS bit bang mode.
BCD Charger	CBUS0, CBUS1, CBUS2, CBUS3	Battery Charge Detect, indicates when the device is connected to a dedicated battery charger. Active high output.
BCD Charger#	CBUS0, CBUS1, CBUS2, CBUS3	Inverse of BCD Charger
BitBang_WR#	CBUS0, CBUS1, CBUS2, CBUS3	Synchronous and asynchronous bit bang mode WR# strobe output.
BitBang_RD#	CBUS0, CBUS1, CBUS2, CBUS3	Synchronous and asynchronous bit bang mode RD# strobe output.
VBUS Sense	CBUS0, CBUS1, CBUS2, CBUS3	Input to detect when VBUS is present.



CBUS Signal Option	Available On CBUS Pin	Description
Time Stamp	CBUS0, CBUS1, CBUS2, CBUS3	Toggle signal which changes state each time a USB SOF is received
Keep_Awake#	CBUS0, CBUS1, CBUS2, CBUS3	Prevents the device from entering suspend state when unplugged.

Table 3.7 CBUS Configuration Control

*When in USB suspend mode the outputs clocks are also suspended.

4 Function Description

The FT231X is a USB to full handshake serial UART interface device which simplifies USB implementations and reduces external component count by fully integrating an MTP memory, and an integrated clock circuit which requires no external crystal. It has been designed to operate efficiently with USB host controllers by using as little bandwidth as possible when compared to the total USB bandwidth available.

4.1 Key Features

Functional Integration. Fully integrated MTP memory, clock generation, AVCC filtering, Power-On-Reset (POR) and LDO regulators.

Configurable CBUS I/O Pin Options. The fully integrated MTP memory allows configuration of the Control Bus (CBUS) functionality and drive strength selection. There are 4 configurable CBUS I/O pins. These configurable options are detailed in section 3.3

The CBUS lines can be configured with any one of these output options by setting bits in the internal MTP memory. The device is shipped with the most commonly used pin definitions pre-programmed – see Section 8 for details.

Asynchronous Bit Bang Mode with RD# and WR# Strokes. The FT231X supports FTDI's previous chip generation bit-bang mode. In bit-bang mode, the eight UART lines can be switched from the regular interface mode to an 8-bit general purpose I/O port. Data packets can be sent to the device and they will be sequentially sent to the interface at a rate controlled by an internal timer (equivalent to the baud rate pre-scalar). In the FT231X device this mode has been enhanced by outputting the internal RD# and WR# strobes signals which can be used to allow external logic to be clocked by accesses to the bit-bang I/O bus. This option will be described more fully in a separate application note available from FTDI website (www.ftdichip.com).

Synchronous Bit Bang Mode. The FT231X supports synchronous bit bang mode. This mode differs from asynchronous bit bang mode in that the interface pins are only read when the device is written to. This makes it easier for the controlling program to measure the response to an output stimulus as the data returned is synchronous to the output data. An application note, AN232R-01, available from FTDI website (www.ftdichip.com) describes this feature.

Source Power and Power Consumption. The FT231X is capable of operating at a voltage supply between +3.3V and +5.25V with a nominal operational mode current of 8mA and a nominal USB suspend mode current of 125µA. This allows greater margin for peripheral designs to meet the USB suspend mode current limit of 2.5mA. An integrated level converter within the UART interface allows the FT231X to interface to UART logic running at +1.8V to +3.3V (5V tolerant).

4.2 Functional Block Descriptions

The following paragraphs detail each function within the FT231X. Please refer to the block diagram shown in Figure 2.1

Internal MTP Memory. The internal MTP memory in the FT231X is used to store USB Vendor ID (VID), Product ID (PID), device serial number, product description string and various other USB configuration descriptors. The internal MTP memory is also used to configure the CBUS pin functions. The FT231X is supplied with the internal MTP memory pre-programmed as described in Section 8. A user area of the internal MTP memory is available to system designers to allow storing additional data from the user application over USB. The internal MTP memory descriptors can be programmed in circuit, over USB without any additional voltage requirement. The descriptors can be programmed using the FTDI utility software called FT_PROG, which can be downloaded from FTDI Utilities on the FTDI website (www.ftdichip.com).

+3.3V LDO Regulator. The +3.3V LDO regulator generates the +3.3V reference voltage for driving the USB transceiver cell output buffers. It requires an external decoupling capacitor to be attached to the 3V3OUT regulator output pin. It also provides +3.3V power to the 1.5kΩ internal pull up resistor on USBDP. The main function of the LDO is to power the USB Transceiver and the Reset Generator Cells rather than to power external logic. However, it can be used to supply external circuitry requiring a +3.3V nominal supply with a maximum current of 50mA.

+1.8V LDO Regulator. The +1.8V LDO regulator generates the +1.8V reference voltage for internal use driving the IC core functions of the serial interface engine and USB protocol engine.

USB Transceiver. The USB Transceiver Cell provides the USB 1.1 / USB 2.0 full-speed physical interface to the USB cable. The output drivers provide +3.3V level slew rate control signalling, whilst a differential input receiver and two single ended input receivers provide USB data in, Single-Ended-0 (SE0) and USB reset detection conditions respectfully. This function also incorporates a 1.5kΩ pull up resistor on USB DP. The block also detects when connected to a USB power supply which will not enumerate the device but still supply power and may be used for battery charging.

USB DPLL. The USB DPLL cell locks on to the incoming NRZI USB data and generates recovered clock and data signals for the Serial Interface Engine (SIE) block.

Internal 12MHz Oscillator – The Internal 12MHz Oscillator cell generates a 12MHz reference clock. This provides an input to the x4 Clock Multiplier function. The 12MHz Oscillator is also used as the reference clock for the SIE, USB Protocol Engine and UART FIFO controller blocks.

Clock Multiplier / Divider. The Clock Multiplier / Divider takes the 12MHz input from the Internal Oscillator function and generates the 48MHz, 24MHz, 12MHz and 6MHz reference clock signals. The 48MHz clock reference is used by the USB DPLL and the Baud Rate Generator blocks.

Serial Interface Engine (SIE). The Serial Interface Engine (SIE) block performs the parallel to serial and serial to parallel conversion of the USB data. In accordance with the USB 2.0 specification, it performs bit stuffing/un-stuffing and CRC5/CRC16 generation. It also verifies the CRC on the USB data stream.

USB Protocol Engine. The USB Protocol Engine manages the data stream from the device USB control endpoint. It handles the low level USB protocol requests generated by the USB host controller and the commands for controlling the functional parameters of the UART in accordance with the USB 2.0 specification chapter 9.

FIFO RX Buffer (512 bytes). Data sent from the USB host controller to the UART via the USB data OUT endpoint is stored in the FIFO RX (receive) buffer. Data is removed from the buffer to the UART transmit register under control of the UART FIFO controller. (Rx relative to the USB interface).

FIFO TX Buffer (512 bytes). Data from the UART receive register is stored in the TX buffer. The USB host controller removes data from the FIFO TX Buffer by sending a USB request for data from the device data IN endpoint. (Tx relative to the USB interface).

UART FIFO Controller. The UART FIFO controller handles the transfer of data between the FIFO RX and TX buffers and the UART transmit and receive registers.

UART Controller with Programmable Signal Inversion and High Drive. Together with the UART FIFO Controller the UART Controller handles the transfer of data between the FIFO RX and FIFO TX buffers and the UART transmit and receive registers. It performs asynchronous 7 or 8 bit parallel to serial and serial to parallel conversion of the data on the RS232 (or RS422 or RS485) interface.

Control signals supported by UART mode include RTS, CTS, DSR, DTR, DCD and RI. The UART Controller also provides a transmitter enable control signal pin option (TXDEN) to assist with interfacing to RS485 transceivers. RTS/CTS, DSR/DTR and XON / XOFF handshaking options are also supported. Handshaking is handled in hardware to ensure fast response times. The UART interface also supports the RS232 BREAK setting and detection conditions.

Additionally, the UART signals can each be individually inverted and have a configurable high drive strength capability. Both these features are configurable in the MTP memory.

Baud Rate Generator – The Baud Rate Generator provides a 16x clock input to the UART Controller from the 48MHz reference clock. It consists of a 14 bit pre-scalar and 3 register bits which provide fine tuning of the baud rate (used to divide by a number plus a fraction or “sub-integer”). This determines the baud rate of the UART, which is programmable from 183 baud to 3 Mbaud.

The FT231X supports all standard baud rates and non-standard baud rates from 183 Baud up to 3 Mbaud. Achievable non-standard baud rates are calculated as follows –

$$\text{Baud Rate} = 3000000 / (n + x)$$

where ‘n’ can be any integer between 2 and 16,384 ($= 2^{14}$) and ‘x’ can be a sub-integer of the value 0, 0.125, 0.25, 0.375, 0.5, 0.625, 0.75, or 0.875. When $n = 1$, $x = 0$, i.e. baud rate divisors with values between 1 and 2 are not possible.

This gives achievable baud rates in the range 183.1 baud to 3,000,000 baud. When a non-standard baud rate is required simply pass the required baud rate value to the driver as normal, and the FTDI driver will calculate the required divisor, and set the baud rate. See FTDI application note AN232B-05 on the FTDI website (www.ftdichip.com) for more details.



RESET Generator – The integrated Reset Generator Cell provides a reliable power-on reset to the device internal circuitry at power up. The RESET# input pin allows an external device to reset the FT231X.

RESET# can be tied to 3V3OUT.

5 Devices Characteristics and Ratings

5.1 Absolute Maximum Ratings

The absolute maximum ratings for the FT231X devices are as follows. These are in accordance with the Absolute Maximum Rating System (IEC 60134). Exceeding these may cause permanent damage to the device.

Parameter	Value	Unit	Conditions
Storage Temperature	-65°C to 150°C	Degrees C	
Floor Life (Out of Bag) At Factory Ambient (30°C / 60% Relative Humidity)	168 Hours (IPC/JEDEC J-STD-033A MSL Level 3 Compliant)*	Hours	
Ambient Operating Temperature (Power Applied)	-40°C to 85°C	Degrees C	
MTTF FT231XS	TBD	Hours	
MTTF FT231XQ	TBD	Hours	
VCC Supply Voltage	-0.3 to +5.5	V	
VCCIO IO Voltage	-0.3 to +4.0	V	
DC Input Voltage – USBDP and USBDM	-0.5 to +3.63	V	
DC Input Voltage – High Impedance Bi-directionals (powered from VCCIO)	-0.3 to +5.8	V	
DC Output Current – Outputs	22	mA	
ESD Charge Device Mode(CDM)	500	V	Class III
ESD Human Body Mode (HDM)	2000	V	Class 2

Table 5.1 Absolute Maximum Ratings

* If devices are stored out of the packaging beyond this time limit the devices should be baked before use. The devices should be ramped up to a temperature of +125°C and baked for up to 17 hours.

5.2 ESD and Latch-up Specifications

Description	Specification
Human Body Mode (HBM)	> ± 2kV
Machine mode (MM)	> ± 200V
Charged Device Mode (CDM)	> ± 500V
Latch-up	> ± 200mA

Table 5.2 ESD and Latch-Up Specifications

5.3 DC Characteristics

DC Characteristics (Ambient Temperature = -40°C to +85°C)

Parameter	Description	Minimum	Typical	Maximum	Units	Conditions
VCC	VCC Operating Supply Voltage	2.97	5	5.5	V	Normal Operation
VCC2	VCCIO Operating Supply Voltage	1.62	---	3.63	V	
Icc1	Operating Supply Current	8	8	8.4	mA	Normal Operation
Icc2	Operating Supply Current		125		μA	USB Suspend
3V3	3.3v regulator output	2.97	3.3	3.63	V	VCC must be greater than 3V3 otherwise 3V3OUT is an input which must be driven with 3.3V

Table 5.3 Operating Voltage and Current

Parameter	Description	Minimum	Typical	Maximum	Units	Conditions
Voh	Output Voltage High	2.97	VCCIO	VCCIO	V	Ioh = +/-2mA I/O Drive strength* = 4mA
		2.97	VCCIO	VCCIO	V	I/O Drive strength* = 8mA
		2.97	VCCIO	VCCIO	V	I/O Drive strength* = 12mA
		2.97	VCCIO	VCCIO	V	I/O Drive strength* = 16mA
Vol	Output Voltage Low		0	0.4	V	Iol = +/-2mA I/O Drive strength* = 4mA
			0	0.4	V	I/O Drive strength* = 8mA
			0	0.4	V	I/O Drive strength* = 12mA
			0	0.4	V	I/O Drive strength* = 16mA
Vil	Input low Switching Threshold			0.8	V	LVTTL
Vih	Input High Switching Threshold	2.0			V	LVTTL
Vt	Switching Threshold		1.49		V	LVTTL
Vt-	Schmitt trigger negative going threshold voltage		1.15		V	
Vt+	Schmitt trigger positive going threshold voltage		1.64		V	
Rpu	Input pull-up resistance	40	75	190	KΩ	Vin = 0
Rpd	Input pull-down resistance	40	75	190	KΩ	Vin = VCCIO
Iin	Input Leakage Current	-10	+/-1	10	μA	Vin = 0
Ioz	Tri-state output leakage current	-10	+/-1	10	μA	Vin = 5.5V or 0

Table 5.4 I/O Pin Characteristics VCCIO = +3.3V (except USB PHY pins)

* The I/O drive strength and slow slew-rate are configurable in the MTP memory.

Parameter	Description	Minimum	Typical	Maximum	Units	Conditions
Voh	Output Voltage High	2.25	VCCIO	VCCIO	V	Ioh = +/-2mA I/O Drive strength* = 4mA
		2.25	VCCIO	VCCIO	V	I/O Drive strength* = 8mA
		2.25	VCCIO	VCCIO	V	I/O Drive strength* = 12mA
		2.25	VCCIO	VCCIO	V	I/O Drive strength* = 16mA
Vol	Output Voltage Low		0	0.4	V	Iol = +/-2mA I/O Drive strength* = 4mA
			0	0.4	V	I/O Drive strength* = 8mA
			0	0.4	V	I/O Drive strength* = 12mA
			0	0.4	V	I/O Drive strength* = 16mA
Vil	Input low Switching Threshold			0.8	V	LVTTTL
Vih	Input High Switching Threshold	0.8			V	LVTTTL
Vt	Switching Threshold		1.1		V	LVTTTL
Vt-	Schmitt trigger negative going threshold voltage		0.8		V	
Vt+	Schmitt trigger positive going threshold voltage		1.2		V	
Rpu	Input pull-up resistance	40	75	190	KΩ	Vin = 0
Rpd	Input pull-down resistance	40	75	190	KΩ	Vin = VCCIO
Iin	Input Leakage Current	-10	+/-1	10	μA	Vin = 0
Ioz	Tri-state output leakage current	-10	+/-1	10	μA	Vin = 5.5V or 0

Table 5.5 I/O Pin Characteristics VCCIO = +2.5V (except USB PHY pins)

* The I/O drive strength and slow slew-rate are configurable in the MTP memory.

Parameter	Description	Minimum	Typical	Maximum	Units	Conditions
Voh	Output Voltage High	1.62	VCCIO	VCCIO	V	Ioh = +/-2mA I/O Drive strength* = 4mA
		1.62	VCCIO	VCCIO	V	I/O Drive strength* = 8mA
		1.62	VCCIO	VCCIO	V	I/O Drive strength* = 12mA
		1.62	VCCIO	VCCIO	V	I/O Drive strength* = 16mA
Vol	Output Voltage Low		0	0.4	V	Iol = +/-2mA I/O Drive strength* = 4mA
			0	0.4	V	I/O Drive strength* = 8mA
			0	0.4	V	I/O Drive strength* = 12mA
			0	0.4	V	I/O Drive strength* = 16mA
Vil	Input low Switching Threshold			0.77	V	LVTTL
Vih	Input High Switching Threshold	1.6			V	LVTTL
Vt	Switching Threshold		0.77		V	LVTTL
Vt-	Schmitt trigger negative going threshold voltage		0.557		V	
Vt+	Schmitt trigger positive going threshold voltage		0.893		V	
Rpu	Input pull-up resistance	40	75	190	KΩ	Vin = 0
Rpd	Input pull-down resistance	40	75	190	KΩ	Vin = VCCIO
Iin	Input Leakage Current	-10	+/-1	10	μA	Vin = 0
Ioz	Tri-state output leakage current	-10	+/-1	10	μA	Vin = 5.5V or 0

Table 5.6 I/O Pin Characteristics VCCIO = +1.8V (except USB PHY pins)

* The I/O drive strength and slow slew-rate are configurable in the MTP memory.

Parameter	Description	Minimum	Typical	Maximum	Units	Conditions
Voh	Output Voltage High	VCC-0.2			V	
Vol	Output Voltage Low			0.2	V	
Vil	Input low Switching Threshold		-	0.8	V	
Vih	Input High Switching Threshold	2.0	-		V	

Table 5.7 USB I/O Pin (USBDP, USBDM) Characteristics

5.4 MTP Memory Reliability Characteristics

The internal 2048 Byte MTP memory has the following reliability characteristics:

Parameter	Value	Unit
Data Retention	10	Years
Write Cycle	2,000	Cycles
Read Cycle	Unlimited	Cycles

Table 5.8 MTP Memory Characteristics

5.5 Internal Clock Characteristics

The internal Clock Oscillator has the following characteristics:

Parameter	Value			Unit
	Minimum	Typical	Maximum	
Frequency of Operation (see Note 1)	11.98	12.00	12.02	MHz
Clock Period	83.19	83.33	83.47	ns
Duty Cycle	45	50	55	%

Table 5.9 Internal Clock Characteristics

Note 1: Equivalent to +/-1667ppm

6 USB Power Configurations

The following sections illustrate possible USB power configurations for the FT231X. The illustrations have omitted pin numbers for ease of understanding since the pins differ between the FT231XS and FT231XQ package options.

All USB power configurations illustrated apply to both package options for the FT231X device. Please refer to Section 9 for the package option pin-out and signal descriptions.

6.1 USB Bus Powered Configuration

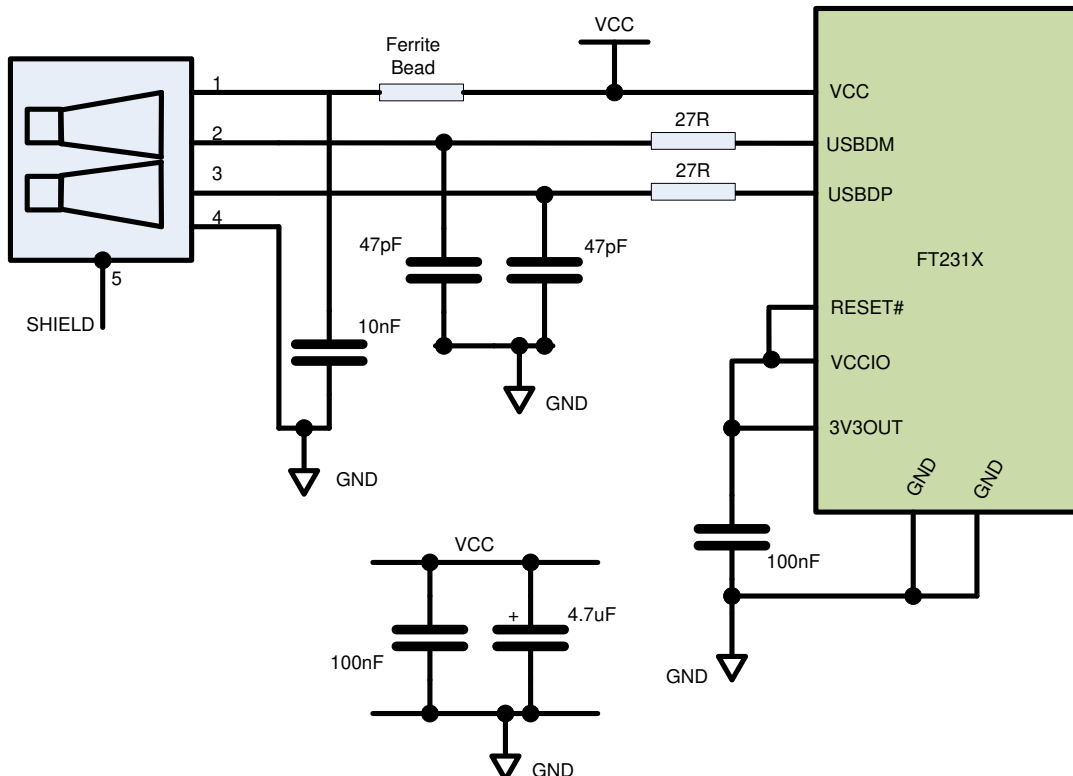

Figure 6.1 Bus Powered Configuration

Figure 6.1 illustrates the FT231X in a typical USB bus powered design configuration. A USB bus powered device gets its power from the USB bus. Basic rules for USB bus power devices are as follows –

- i) On plug-in to USB, the device should draw no more current than 100mA.
- ii) In USB Suspend mode the device should draw no more than 2.5mA.
- iii) A bus powered high power USB device (one that draws more than 100mA) should use one of the CBUS pins configured as PWREN# and use it to keep the current below 100mA on plug-in and 2.5mA on USB suspend.
- iv) A device that consumes more than 100mA cannot be plugged into a USB bus powered hub.
- v) No device can draw more than 500mA from the USB bus.

The power descriptors in the internal MTP memory of the FT231X should be programmed to match the current drawn by the device.

A ferrite bead is connected in series with the USB power supply to reduce EMI noise from the FT231X and associated circuitry being radiated down the USB cable to the USB host. The value of the Ferrite Bead depends on the total current drawn by the application. A suitable range of Ferrite Beads is available from Laird Technologies (<http://www.lairdtech.com>), for example Laird Technologies Part # MI0805K400R-10.

Note: If using PWREN# (available using the CBUS) the pin should be pulled to VCCIO using a 10kΩ resistor.

6.2 Self Powered Configuration

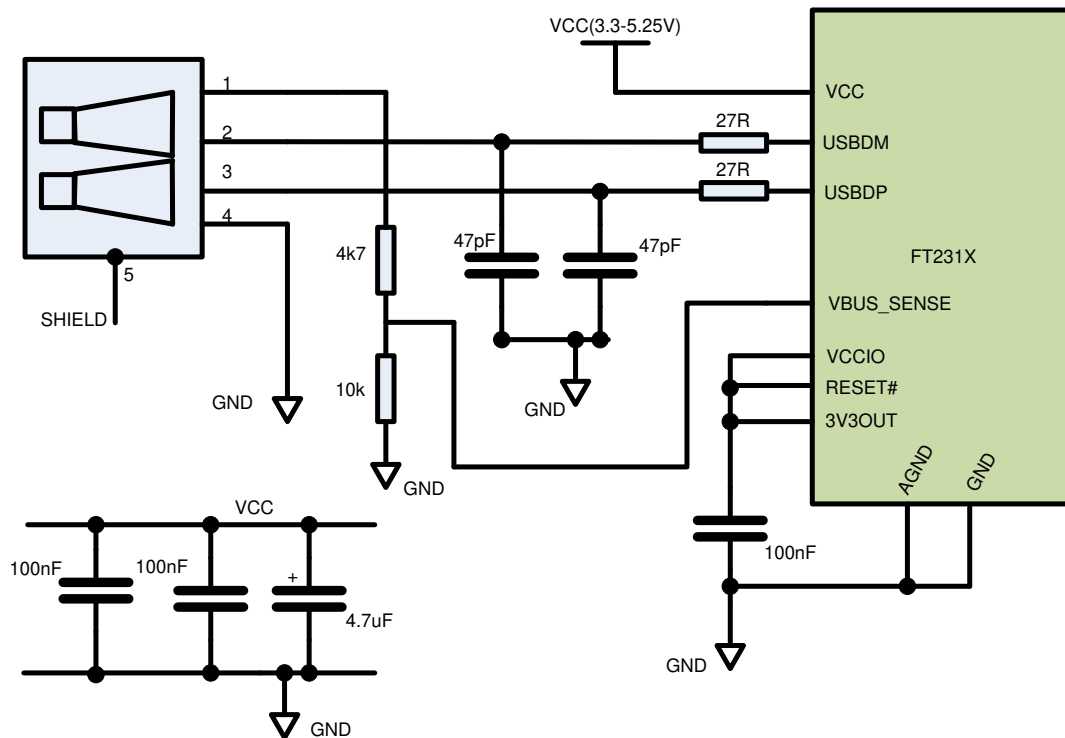

Figure 6.2 Self Powered Configuration

Figure 6.2 illustrates the FT231X in a typical USB self powered configuration. A USB self powered device gets its power from its own power supply, VCC, and does not draw current from the USB bus. The basic rules for USB self powered devices are as follows –

- i) A self powered device should not force current down the USB bus when the USB host or hub controller is powered down.
- ii) A self powered device can use as much current as it needs during normal operation and USB suspend as it has its own power supply.
- iii) A self powered device can be used with any USB host, a bus powered USB hub or a self powered USB hub.

The power descriptor in the internal MTP memory of the FT231X should be programmed to a value of zero (self powered).

In order to comply with the first requirement above, the USB bus power (pin 1) is used to control the VBUS_Sense pin of the FT220X device. When the USB host or hub is powered up an internal 1.5k Ω resistor on USBDP is pulled up to +3.3V, thus identifying the device as a full speed device to the USB host or hub. When the USB host or hub is powered off, VBUS_Sense pin will be low and the FT220X is held in a suspend state. In this state the internal 1.5k Ω resistor is not pulled up to any power supply (hub or host is powered down), so no current flows down USBDP via the 1.5k Ω pull-up resistor. Failure to do this may cause some USB host or hub controllers to power up erratically.

Figure 6.2 illustrates a self powered design which has a +3.3V to +5.25V supply.

Note:

1. When the FT231X is in reset, the UART interface I/O pins are tri-stated. Input pins have internal 200k Ω pull-up resistors to VCCIO, so they will gently pull high unless driven by some external logic.

6.3 USB Bus Powered with Power Switching Configuration

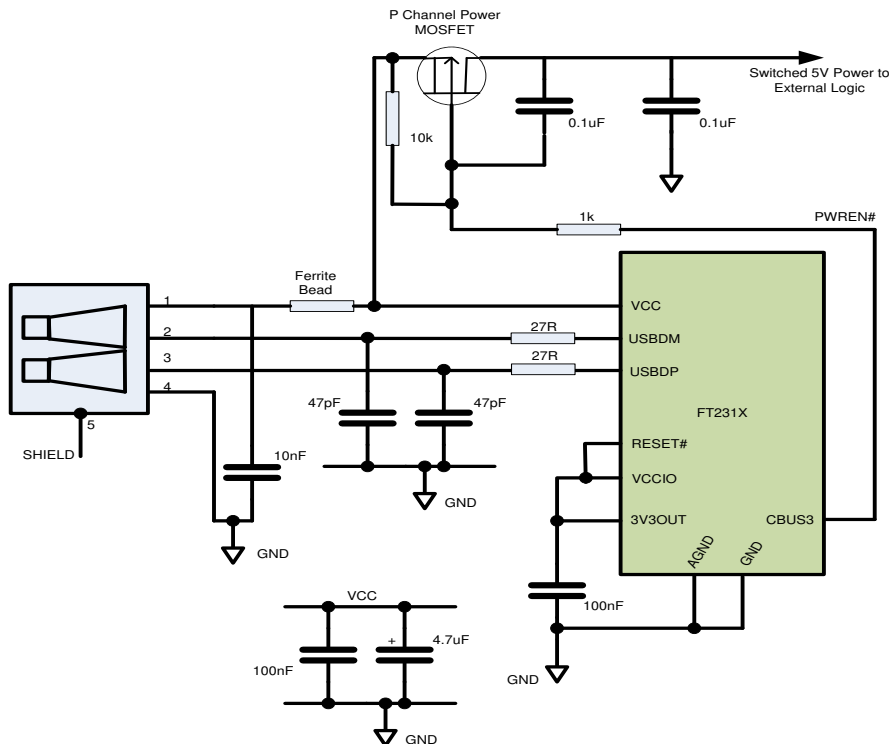

Figure 6.3 Bus Powered with Power Switching Configuration

A requirement of USB bus powered applications, is when in USB suspend mode, the application draws a total current of less than 2.5mA. This requirement includes external logic. Some external logic has the ability to power itself down into a low current state by monitoring the PWREN# signal. For external logic that cannot power itself down in this way, the FT231X provides a simple but effective method of turning off power during the USB suspend mode.

Figure 6.3 shows an example of using a discrete P-Channel MOSFET to control the power to external logic. A suitable device to do this is an International Rectifier (www.irf.com) IRLML6402, or equivalent. It is recommended that a "soft start" circuit consisting of a 1k Ω series resistor and a 0.1 μ F capacitor is used to limit the current surge when the MOSFET turns on. Without the soft start circuit it is possible that the transient power surge, caused when the MOSFET switches on, will reset the FT231X or the USB host/hub controller. The soft start circuit example shown in Figure 6.3 powers up with a slew rate of approximately 12.5V/ms. Thus supply voltage to external logic transitions from GND to +5V in approximately 400 microseconds.

As an alternative to the MOSFET, a dedicated power switch IC with inbuilt "soft-start" can be used. A suitable power switch IC for such an application is the Micrel (www.micrel.com) MIC2025-2BM or equivalent.

With power switching controlled designs the following should be noted:

- i) The external logic to which the power is being switched should have its own reset circuitry to automatically reset the logic when power is re-applied when moving out of suspend mode.
- ii) Set the Pull-down on Suspend option in the internal FT231X MTP memory.
- iii) One of the CBUS Pins should be configured as PWREN# in the internal FT231X MTP memory, and used to switch the power supply to the external circuitry. This should be pulled high through a 10 k Ω resistor.
- iv) For USB high-power bus powered applications (one that consumes greater than 100mA, and up to 500mA of current from the USB bus), the power consumption of the application must be set in the Max Power field in the internal FT231X MTP memory. A high-power bus powered application uses the descriptor in the internal FT231X MTP memory to inform the system of its power requirements.
- v) PWREN# gets its VCC from VCCIO. For designs using 3V3 logic, ensure VCCIO is not powered down using the external logic. In this case use the +3V3OUT.

7 Application Examples

The following sections illustrate possible applications of the FT231X. The illustrations have omitted pin numbers for ease of understanding since the pins differ between the FT231XS and FT231XQ package options.

7.1 USB to RS232 Converter

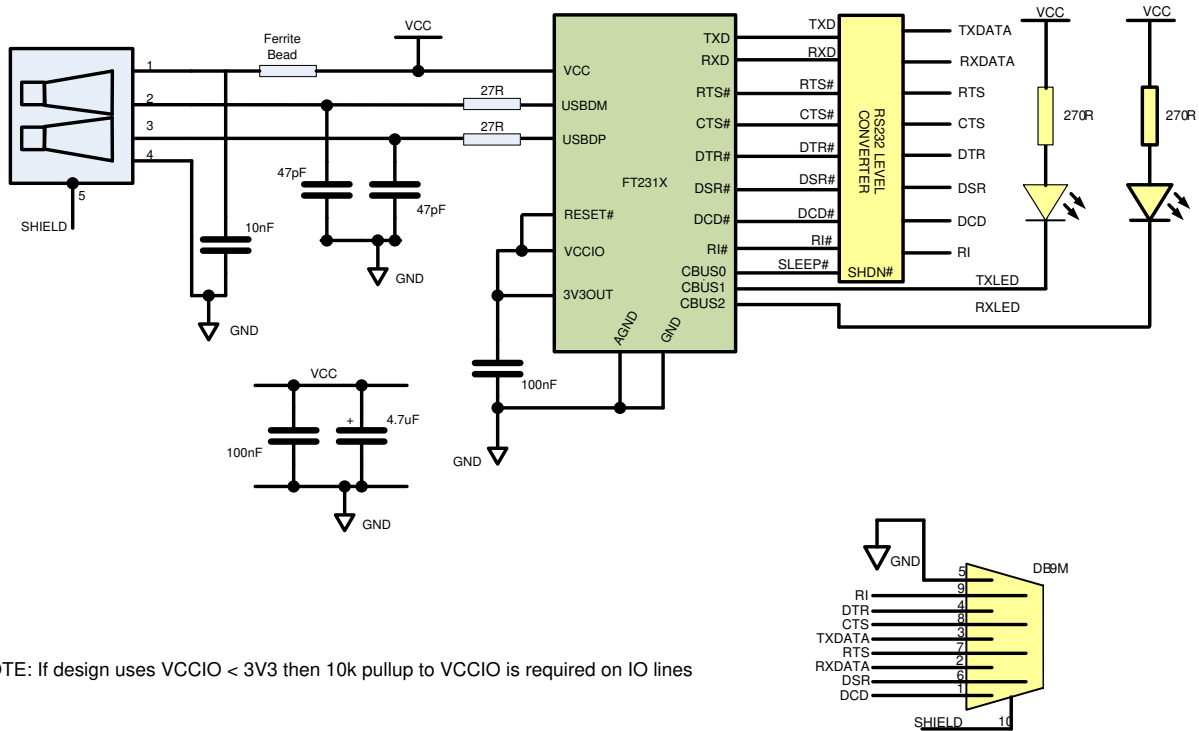

Figure 7.1 Application Example showing USB to RS232 Converter

An example of using the FT231X as a USB to RS232 converter is illustrated in Figure 7.1. In this application, a 3V3 TTL to RS232 Level Converter IC is used on the serial UART interface of the FT231X to convert the 3V3 levels of the FT231X to RS232 levels. This level shift can be done using line drivers from a variety of vendors e.g. Zywyn. A useful feature on some of these devices is the SHDN# pin which can be used to power down the device to a low quiescent current during USB suspend mode.

A suitable level shifting device is the Zywyn ZT3243F which is capable of RS232 communication at up to 1000k baud.

In example shown, the CBUS0 and CBUS1 have been configured as TXLED# and RXLED# and are being used to drive two LEDs.